

033-70441-C-A-02-10-Service iK152-16M-PP

Module-Audio amplifier

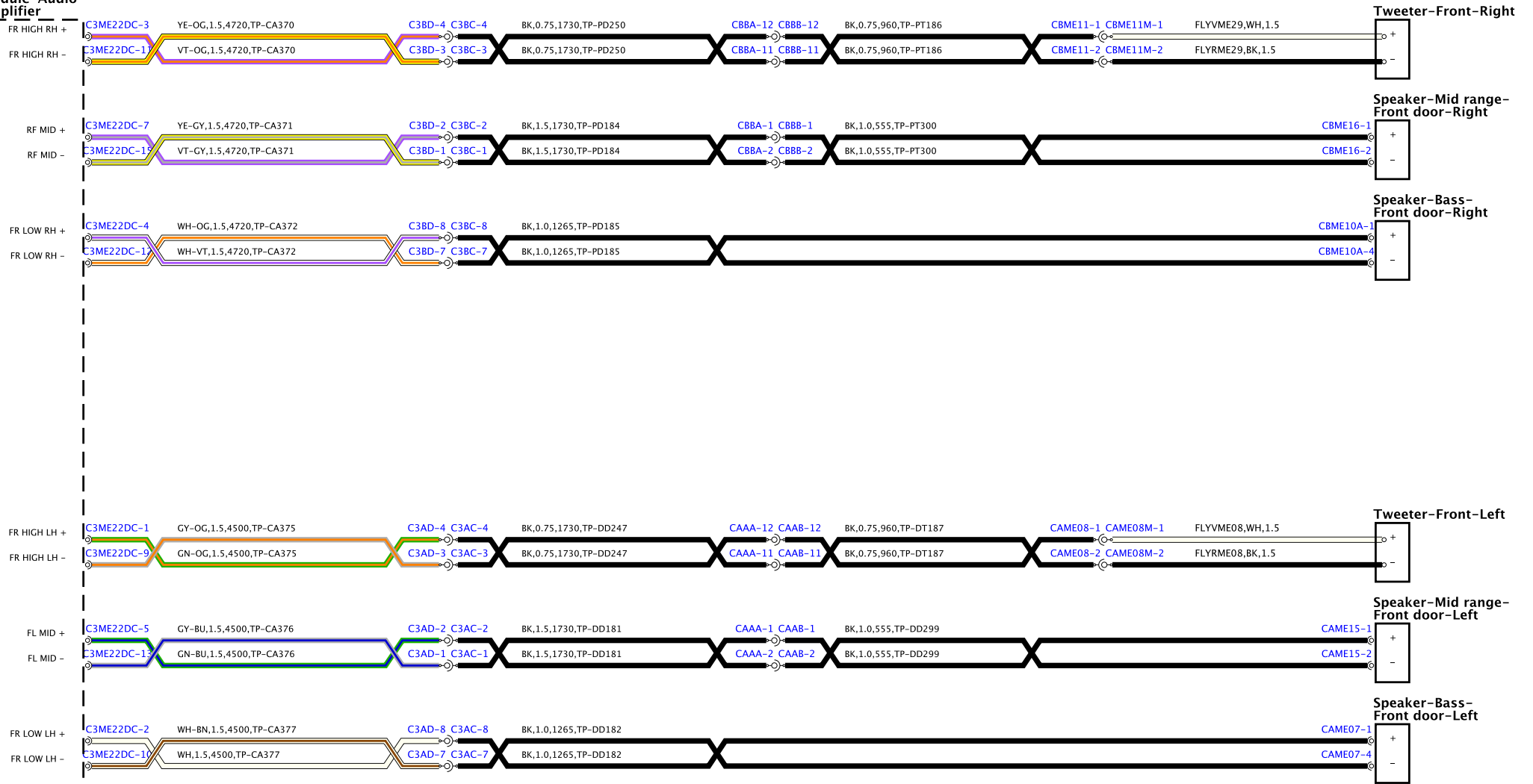

G033-20443-C-A-03-10-Service (K152-100Y-PP)

Module-Audio amplifier

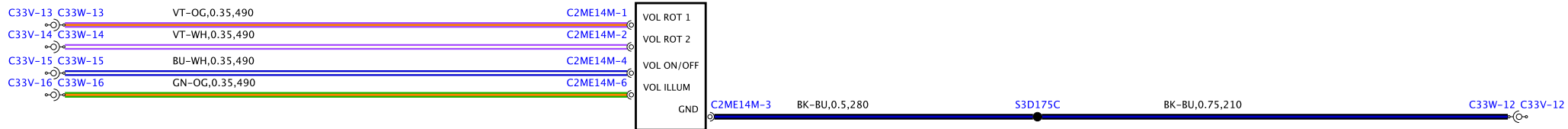

G511-70441-C-A-00-10-Service (6532-10MY-00)

Integrated control panel

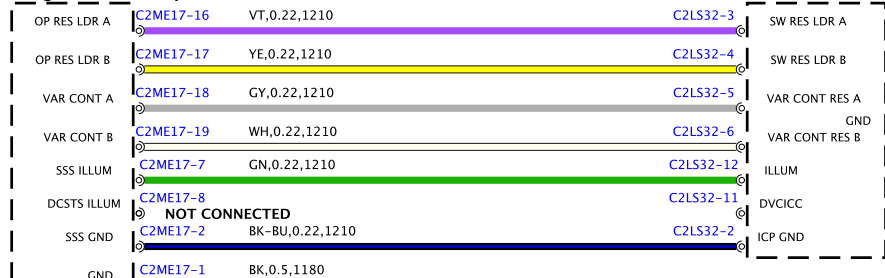

Switchpack-Touch screen

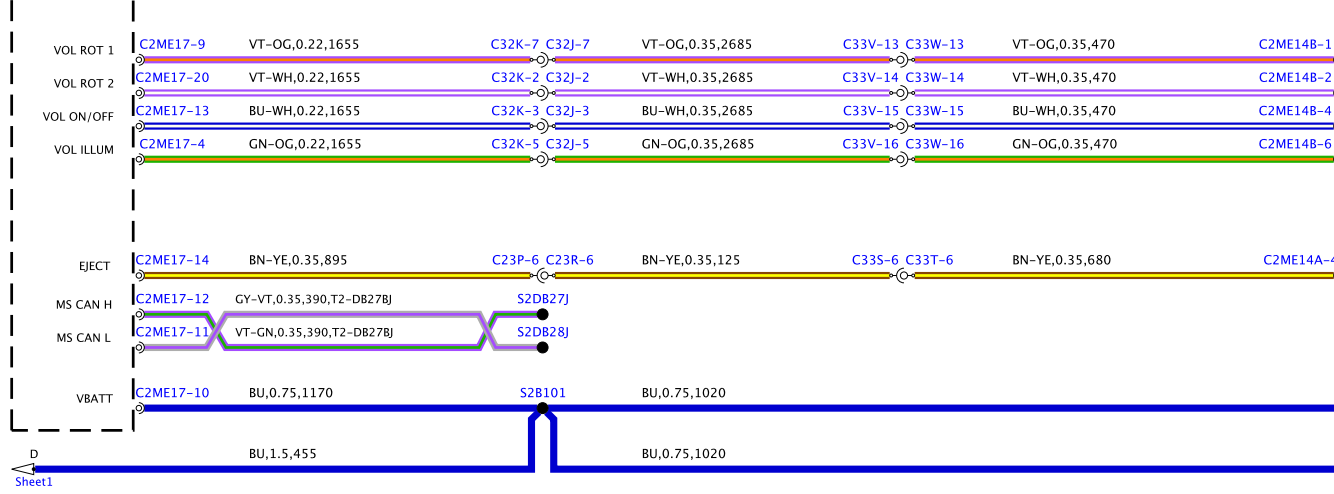
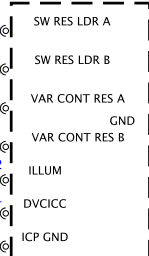

Audio Volume Control Switch

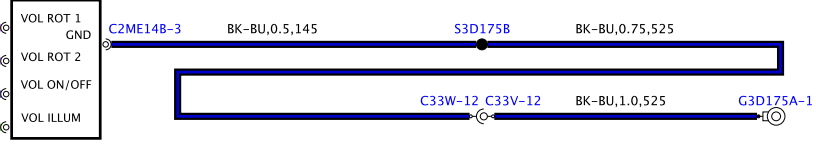

Disc eject switch

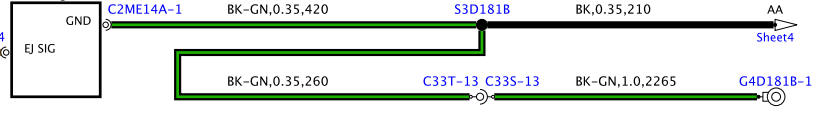

Camera-Rear view

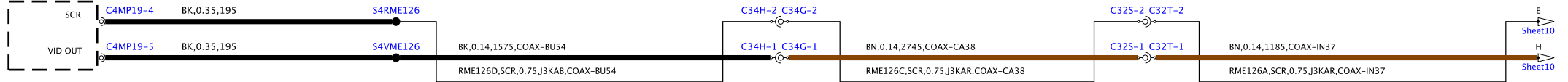

Switchpack-Steering wheel-Left

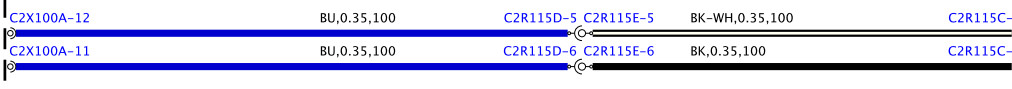
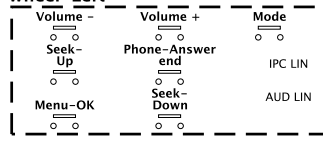

Clockspring

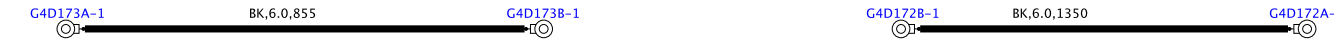
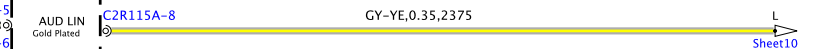

0311-70441-C-A-06-10-Service (R152-10MY-05)

Module-Telephone

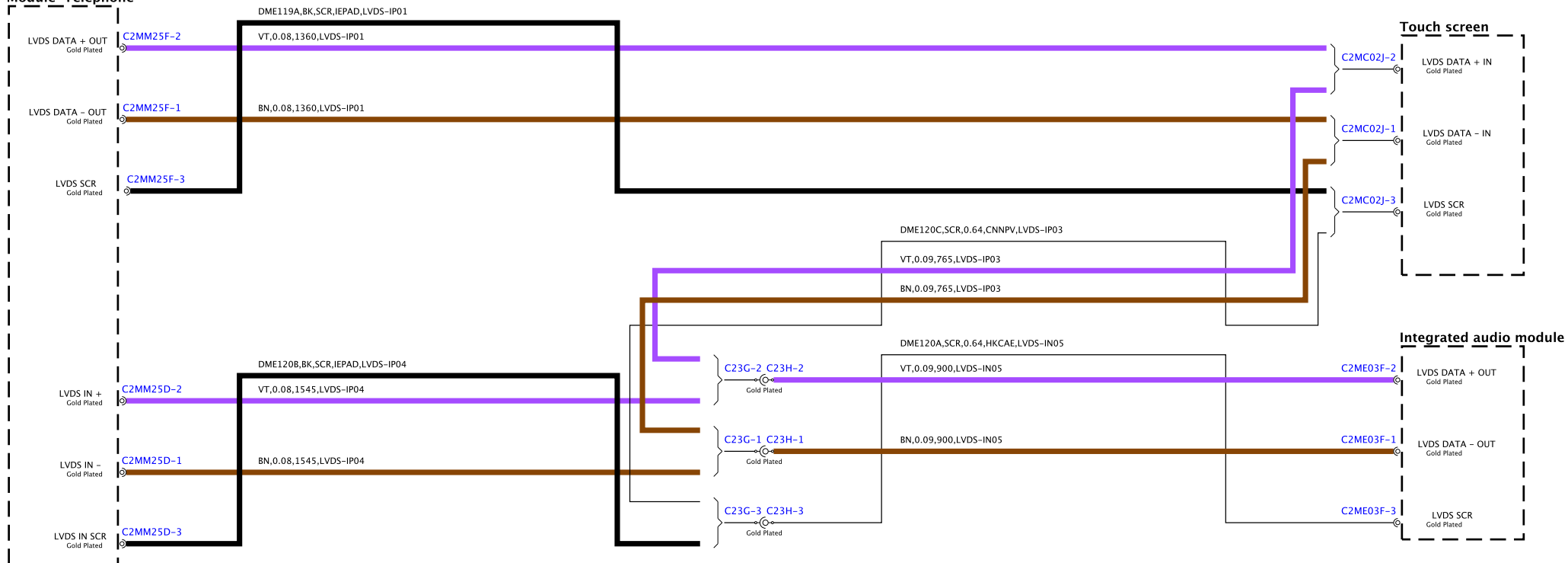

Touch screen

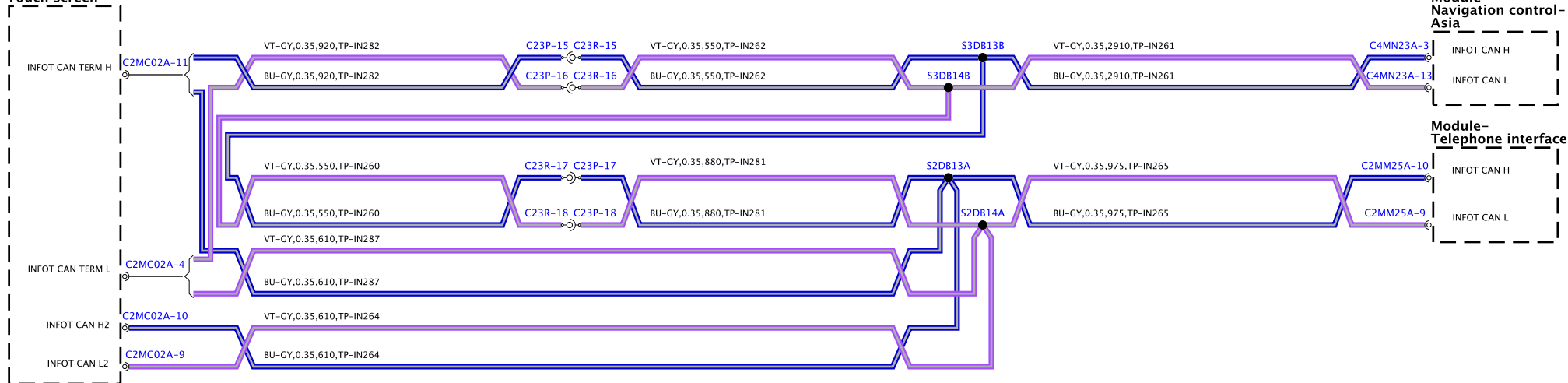

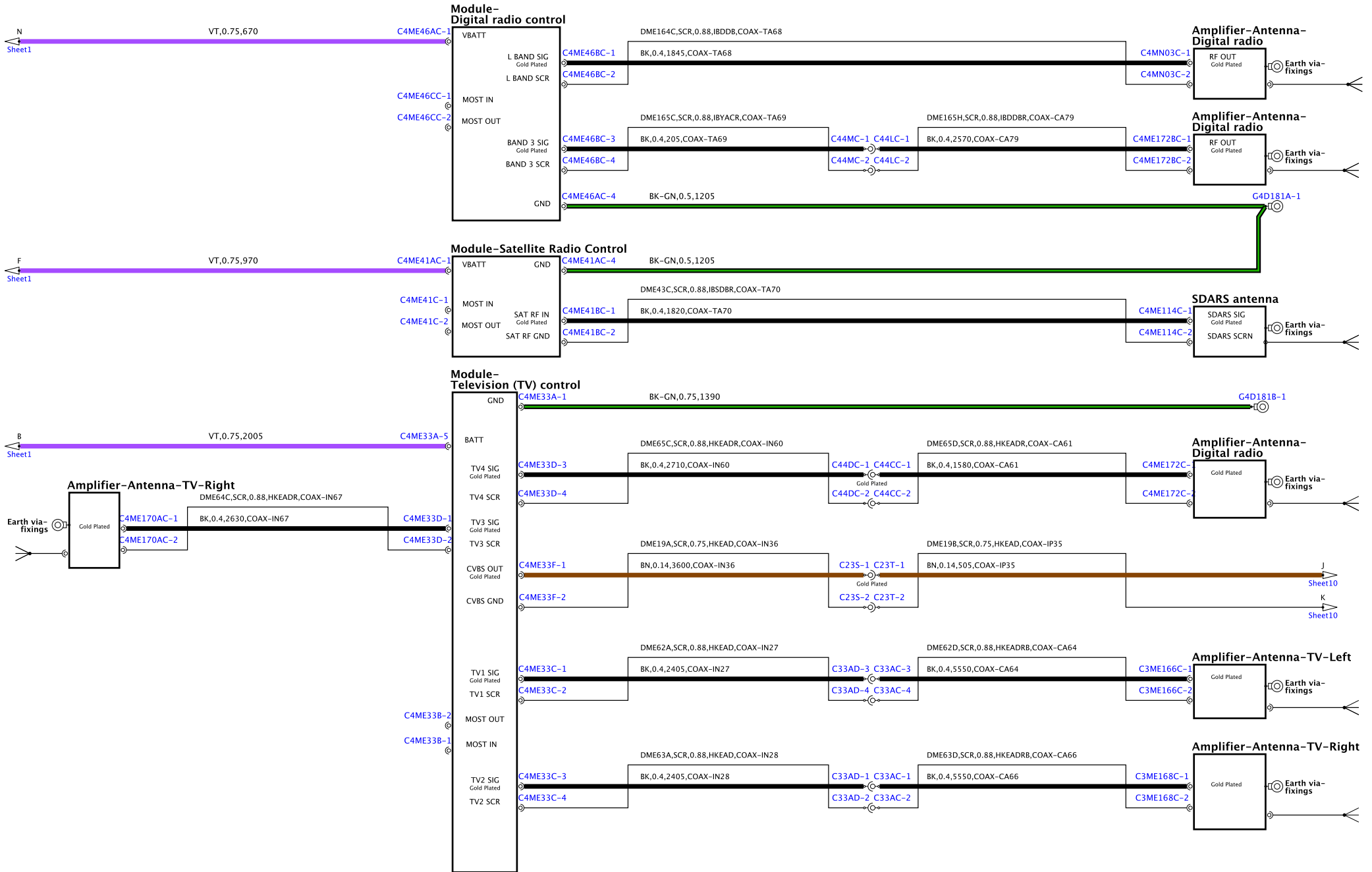

GS3-70443-C-A-08-10-Service (K152-10MY-PP)

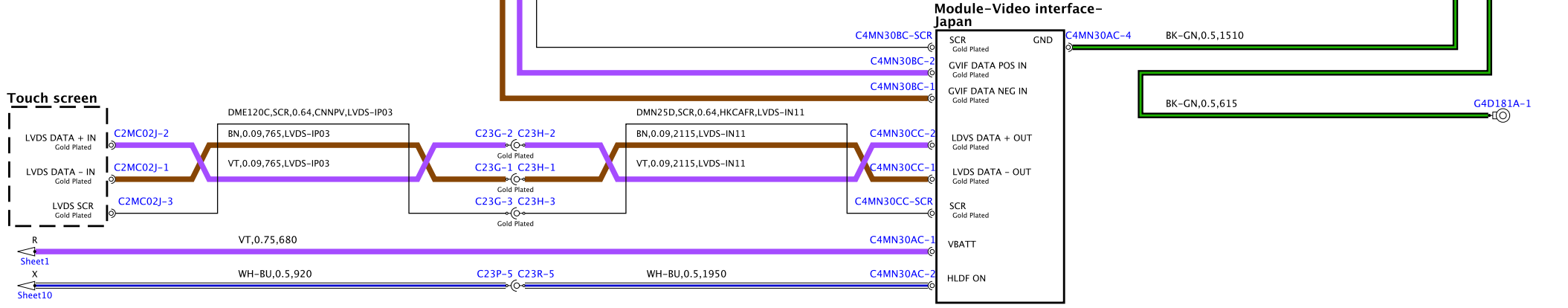
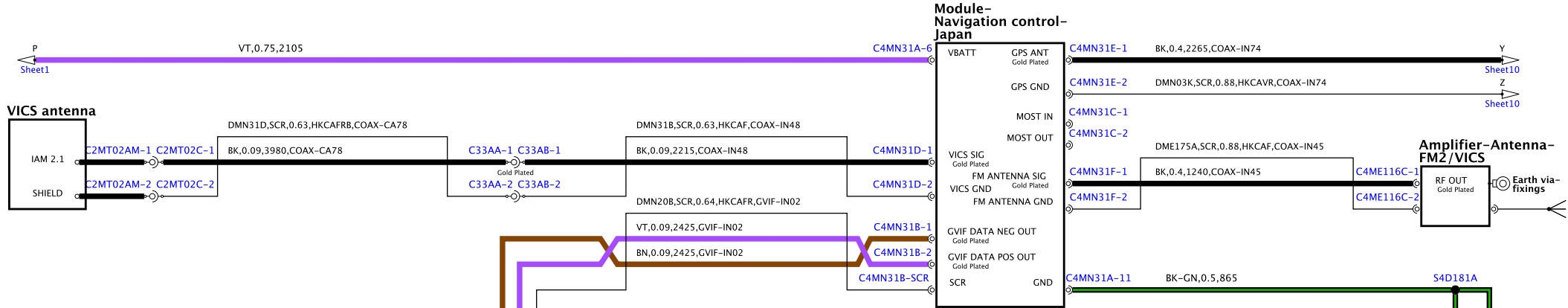
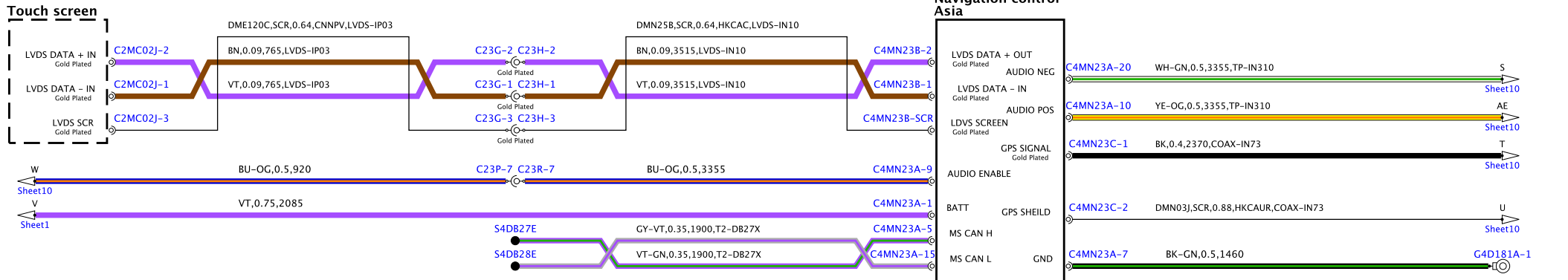

G53-70441-C-A-09-10-Service (8152-10MY-09)

Module-Telephone interface

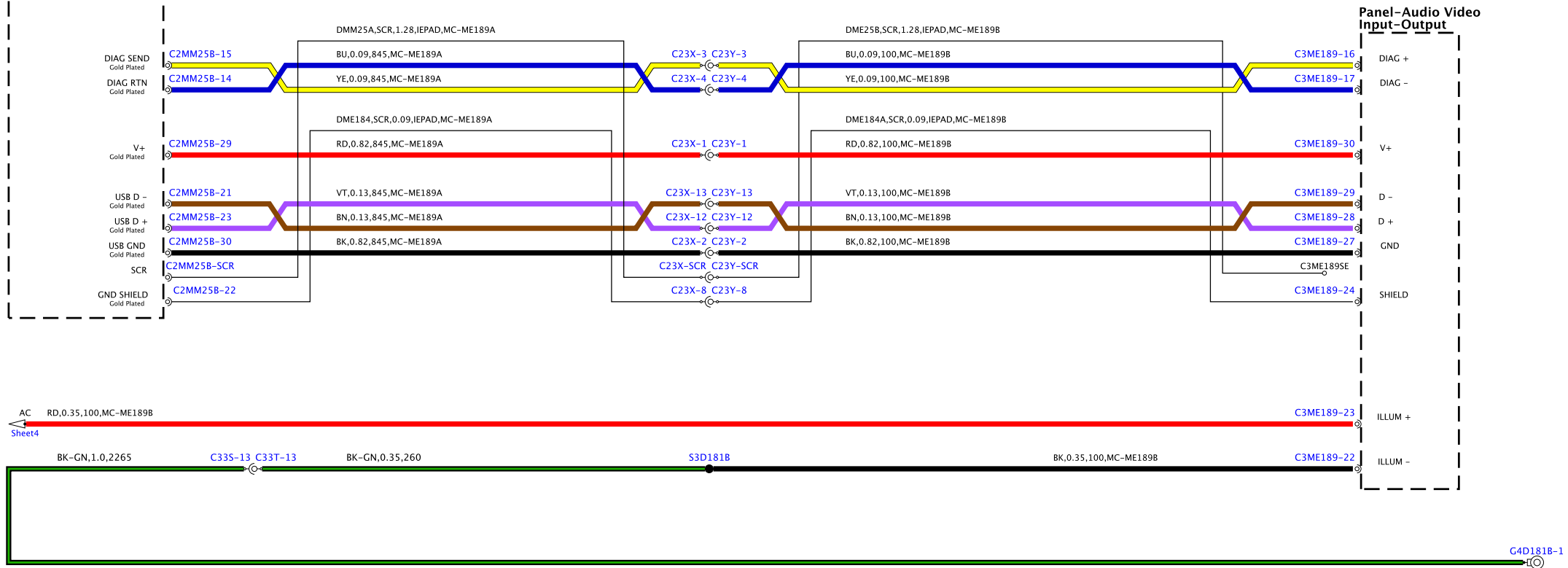
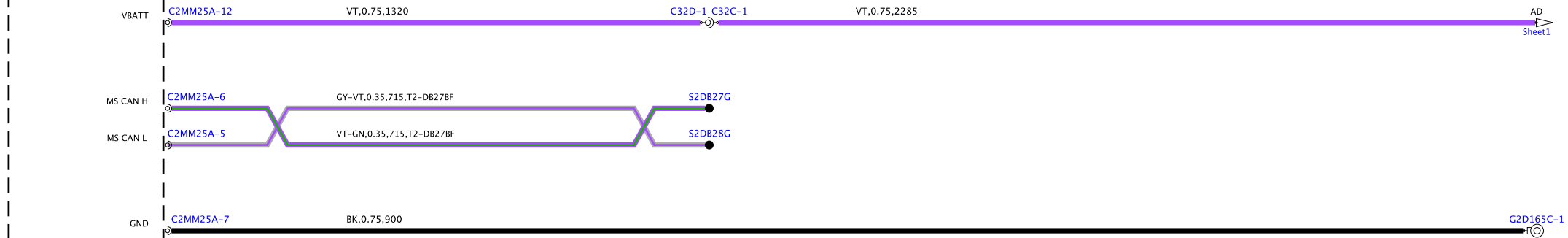

AC Sheet4

G4D181B-1

0511-70441-C-A-10-10-Service (R152-10MY-PP)

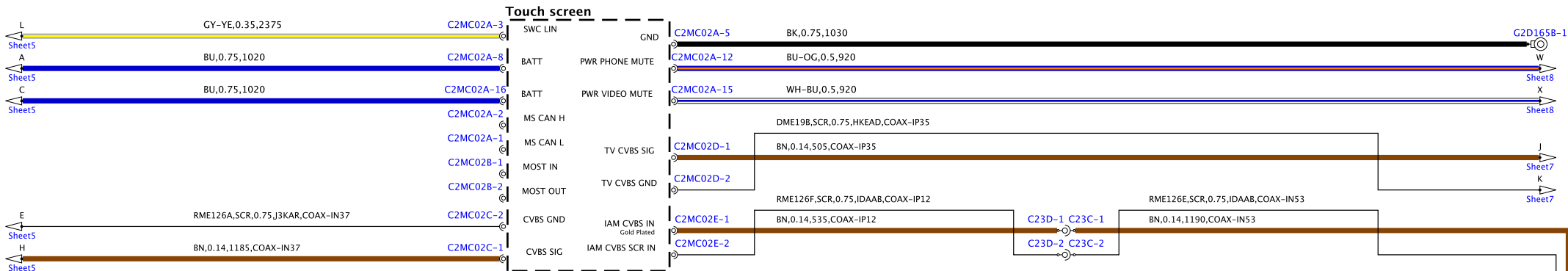

Antenna-Global Positioning System (GPS)

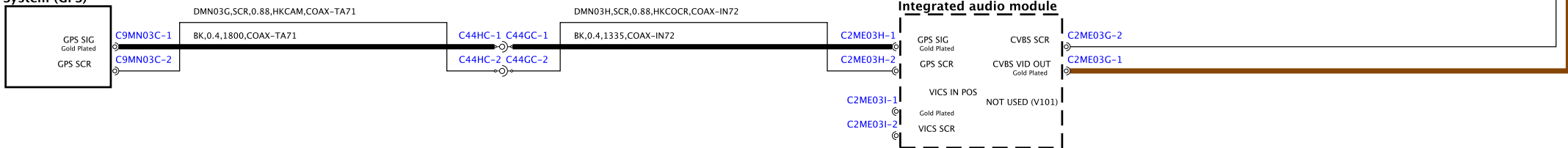

Integrated audio module

