

PUBLISHED: 27-MAR-2013
2015.0 F-TYPE (X152), 501-18B

FOLDING TOP [G1585146]

REMOVAL AND INSTALLATION

76.86.01

**FOLDING
TOP - RENEW**

CABRIOLET

2.90

USED WITHINS

+

REMOVAL

WARNINGS:

- Take extra care when removing and installing the folding top assembly. Make sure the weight is evenly supported. Failure to follow this instruction may result in personal injury.
- Wear protective gloves.

CAUTIONS:

- Take extra care when removing and installing the folding top assembly. Make sure the weight is evenly supported. Failure to follow this instruction may result in damage to the vehicle.
- Protect the surrounding paintwork to avoid damage.
- Protect the folding top material to avoid damage and/or contamination on removal and installation.

NOTE:

Assistance will be required for removal and installation of the folding top.

1.

NOTE:

Repeat the procedure for the other side.

Refer to: [Loadspace Trim Panel - Convertible](#) (501-05 Interior Trim and Ornamentation, Removal and Installation).

2.



3.

NOTE:

Repeat the procedure for the other side.

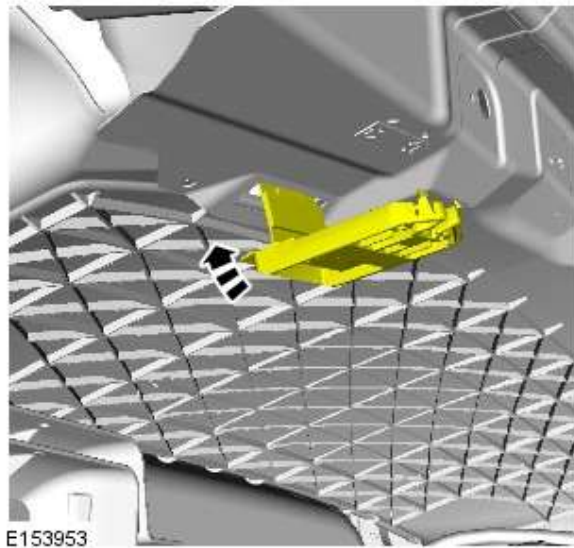

4.

NOTE:

Repeat the procedure for the other side.

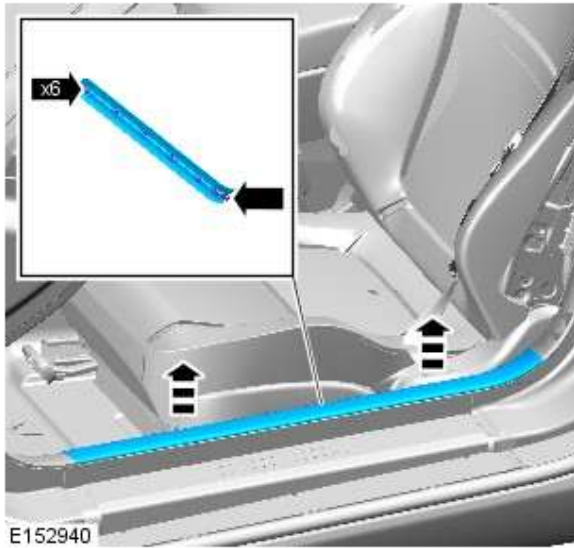

5.

NOTE:

Repeat the procedure for the other side.



6.

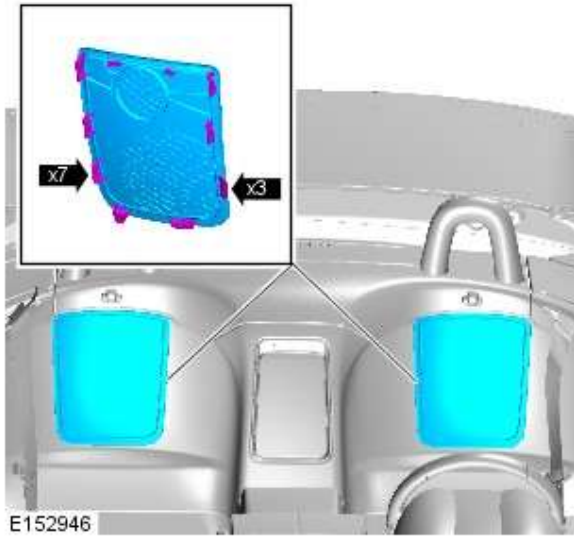

7.

NOTE:

Repeat the procedure for the other side.

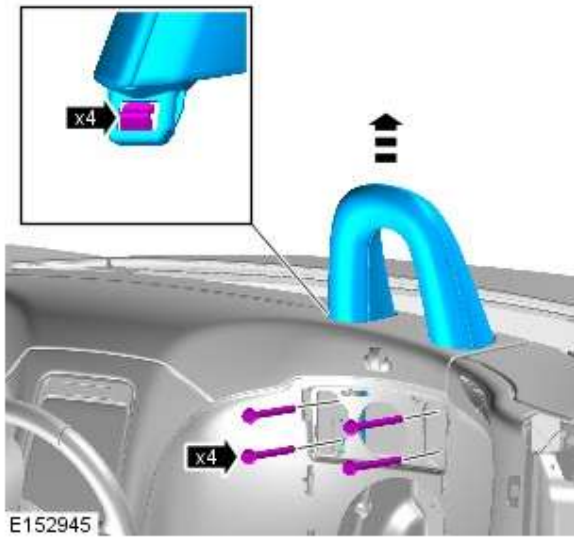

8.

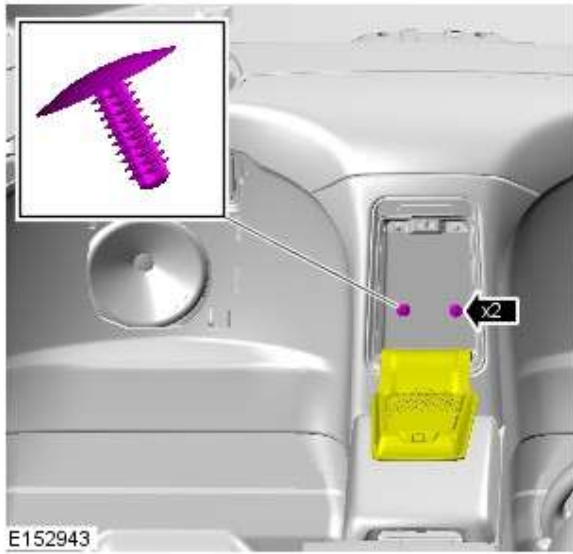

9.

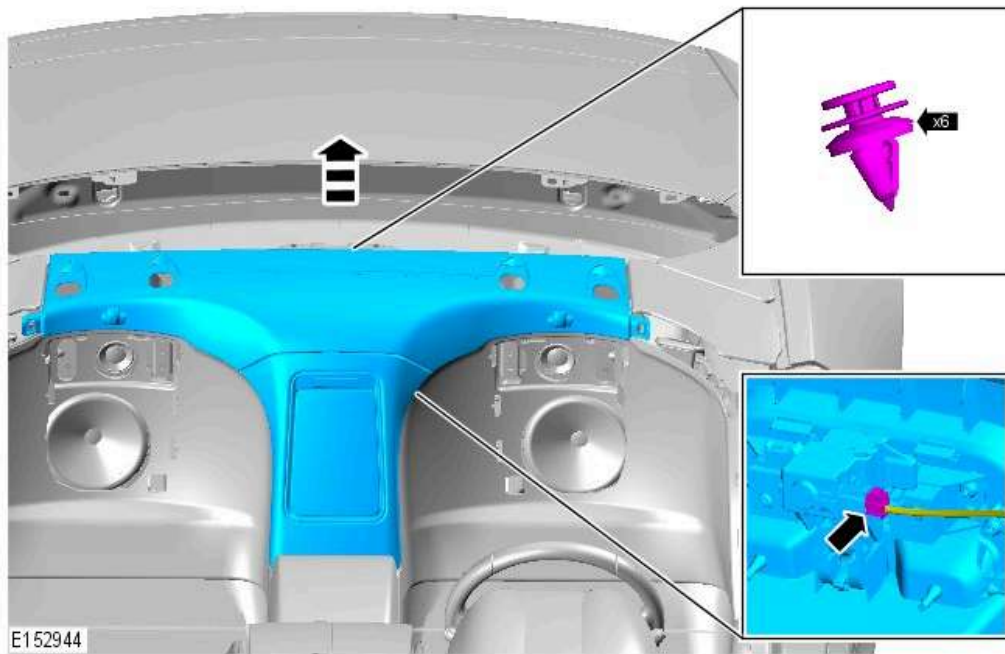

10.

NOTE:

Repeat the procedure for the other side.

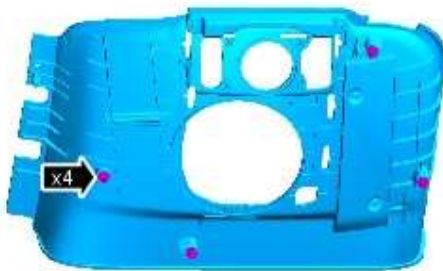
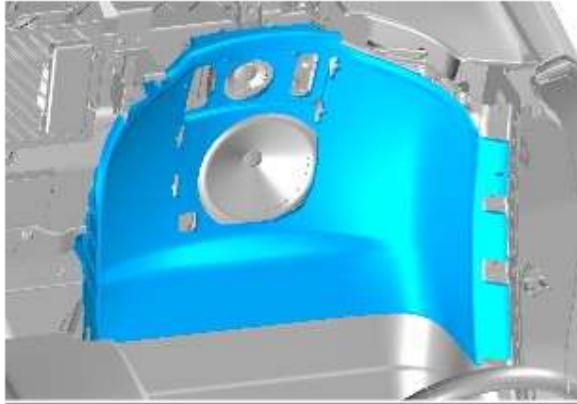

E152941

11.

NOTES:

- A gradual increase in effort will be required to raise the cover flap to the fully vertical position.
- Repeat the procedure for the other side.

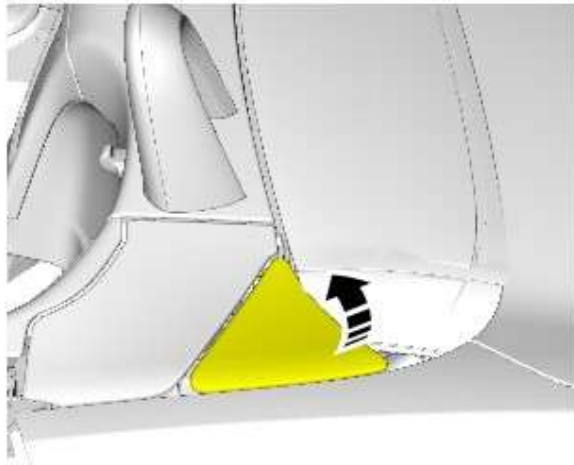

E153954

12.

NOTE:

Repeat the procedure for the other side.

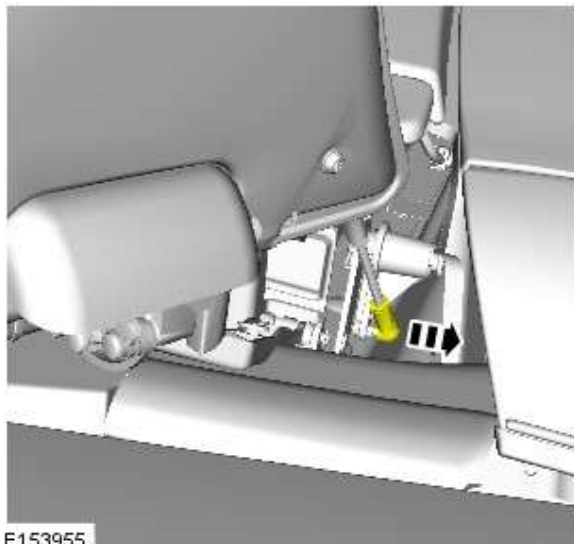

E153955

13.

NOTE:

Repeat the procedure for the other side.

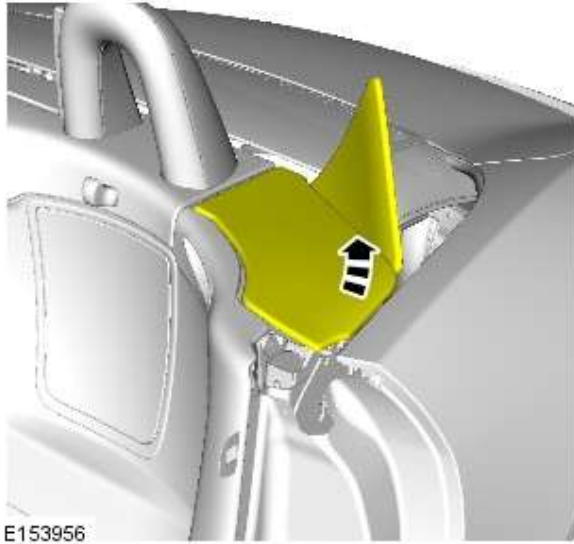

14.

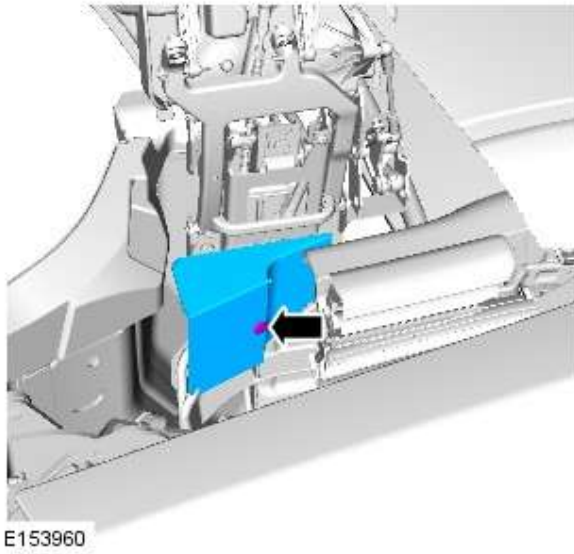

15.

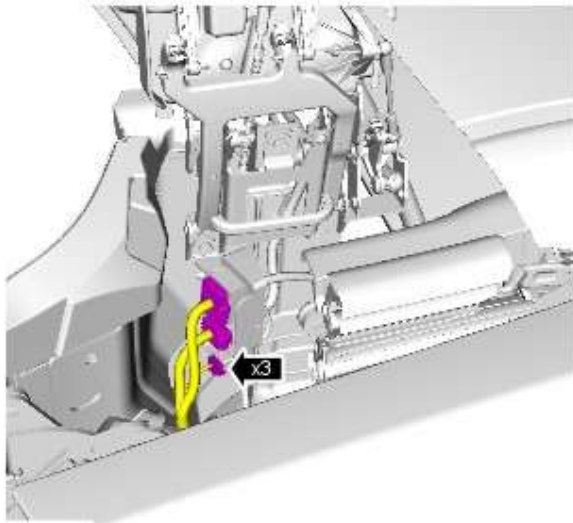

E153961

16.

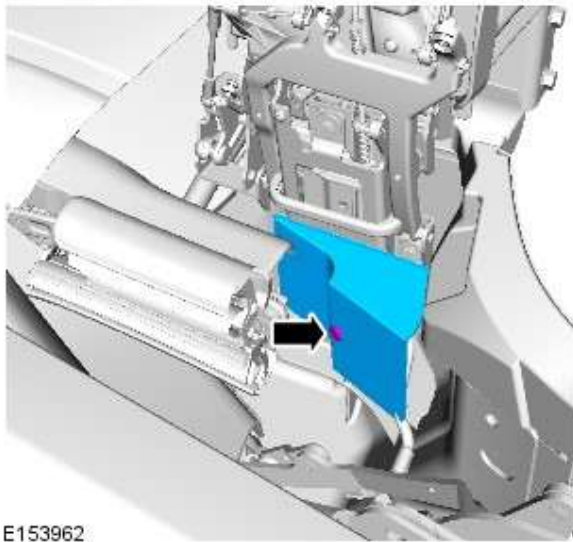

E153962

17.

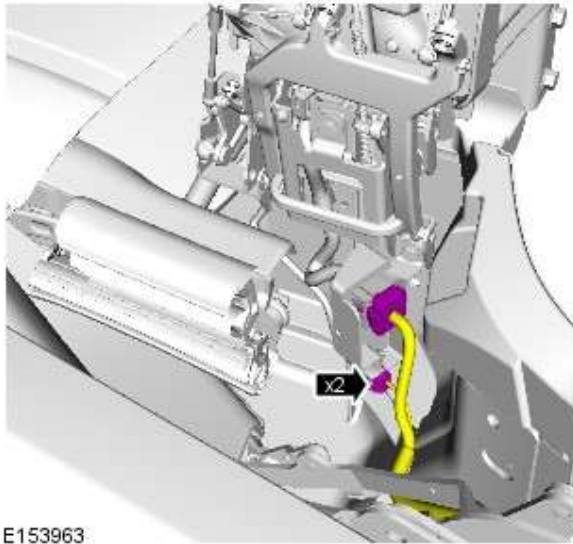

E153963

18.

NOTE:

Repeat the procedure for the other side.

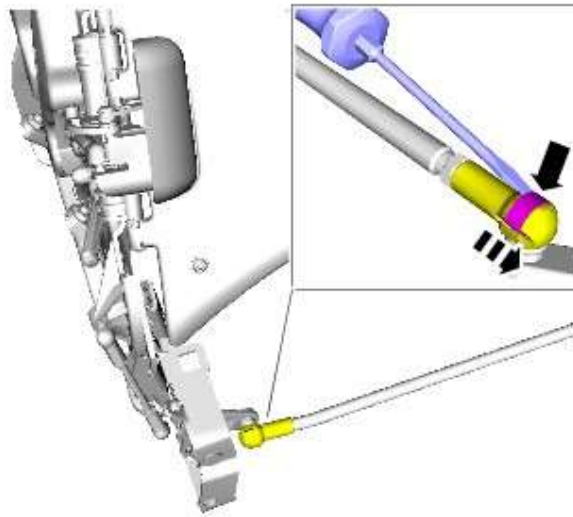

E154575

19.

NOTE:

Repeat the procedure for the other side.

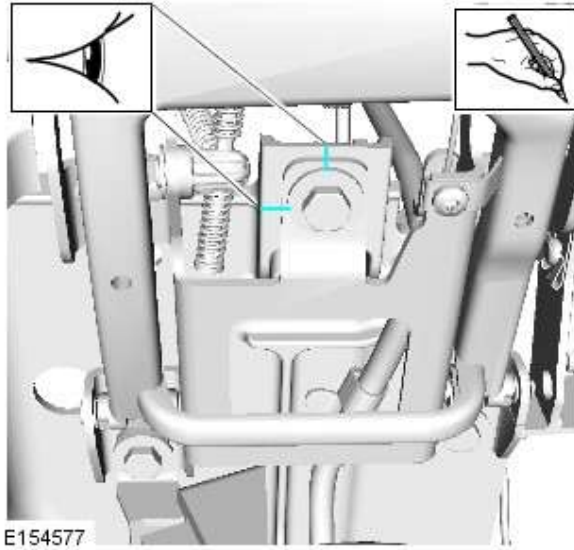

20.

NOTE:

Repeat the procedure for the other side.

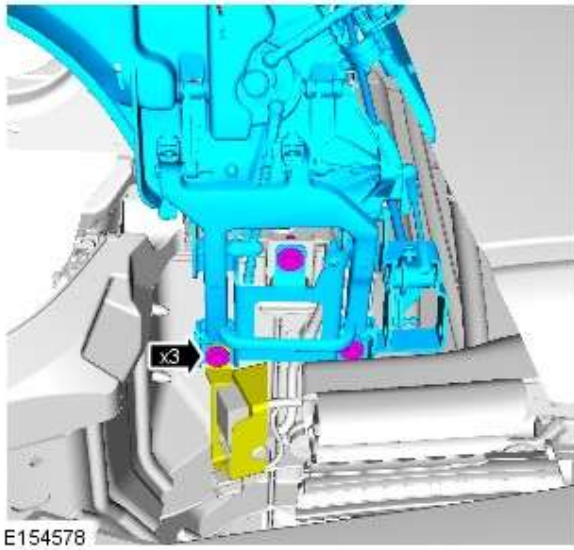

21.

NOTE:

Repeat the procedure for the other side.

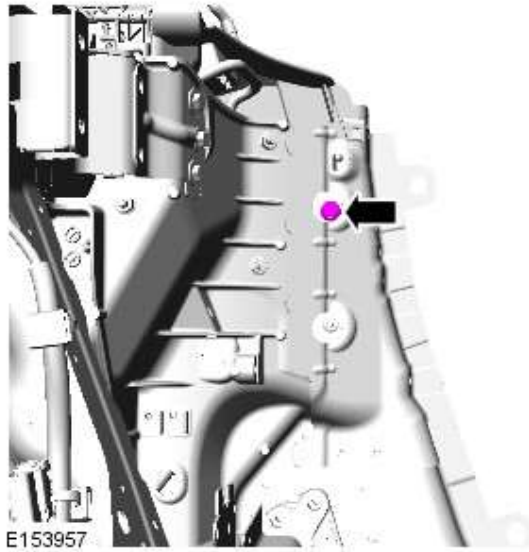

22.

NOTE:

Repeat the procedure for the other side.

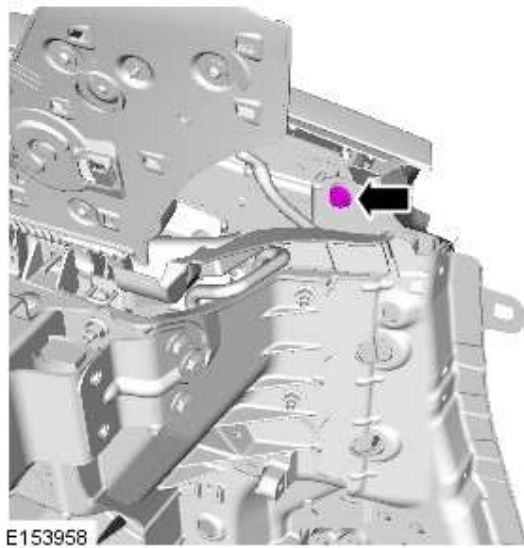

23.

NOTE:

Repeat the procedure for the other side.

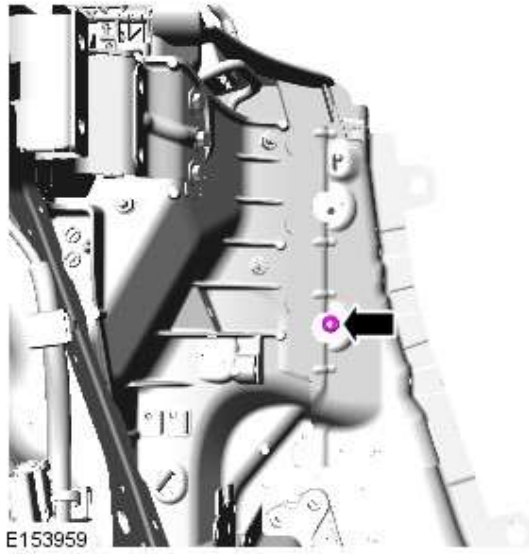

24.

NOTE:

Repeat the procedure for the other side.

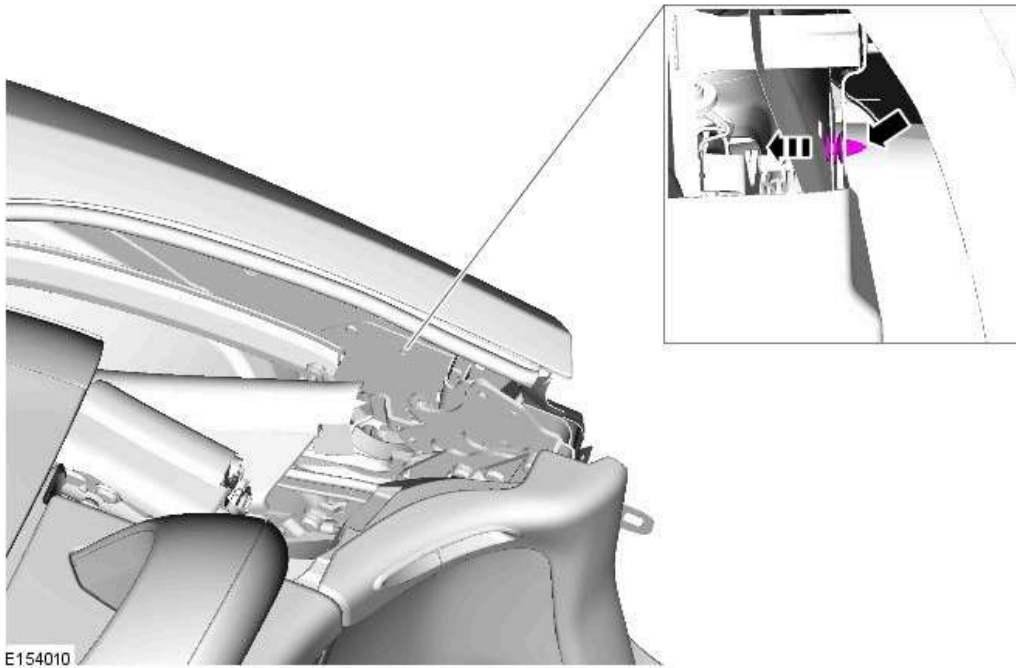

25.

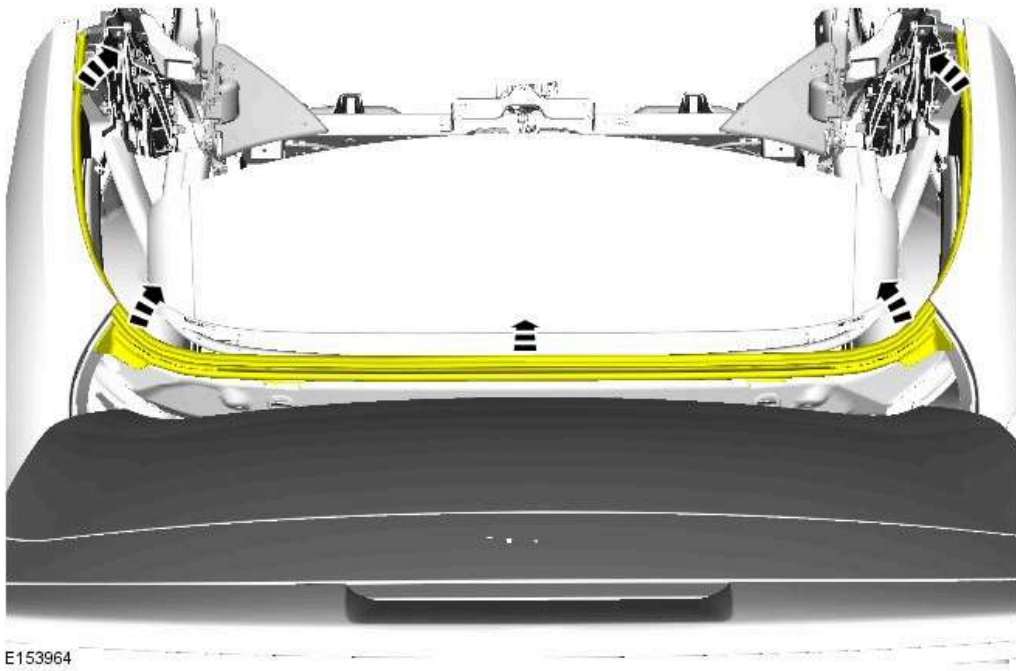

26. Apply the protective tape to the body aperture.

27.

NOTE:

Repeat the procedure for the other side.

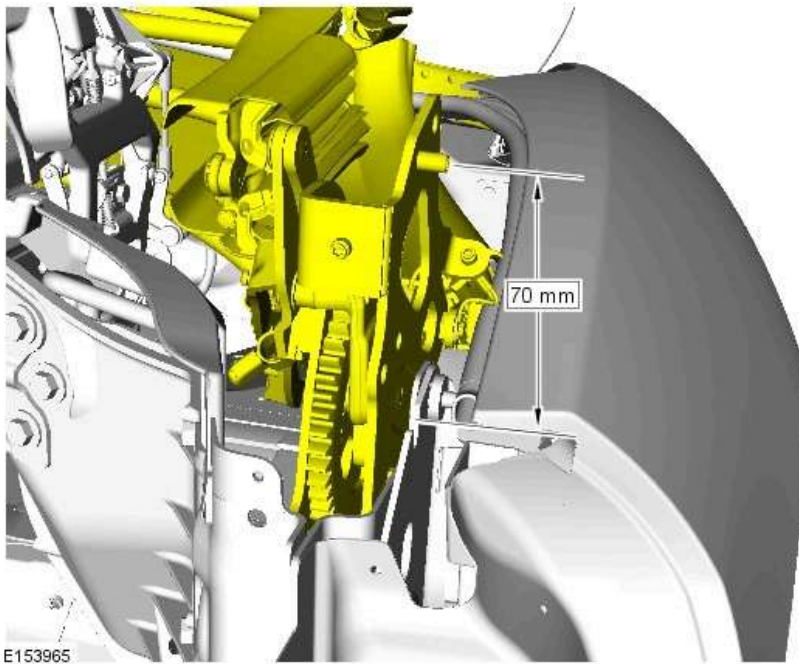

28.

NOTE:

Repeat the procedure for the other side.

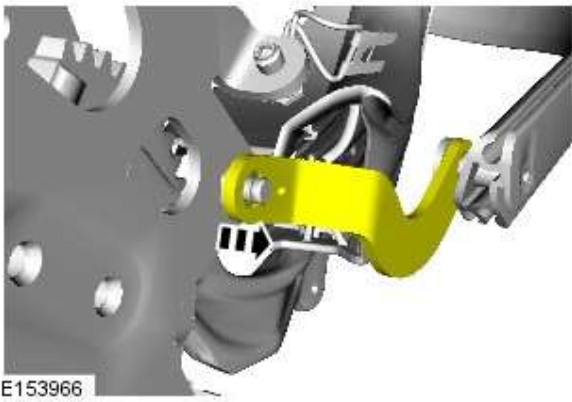
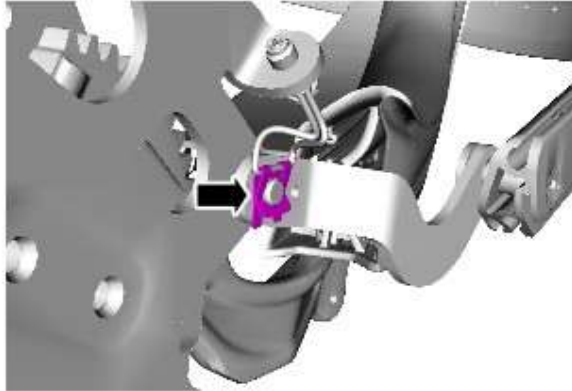

E153966

29.

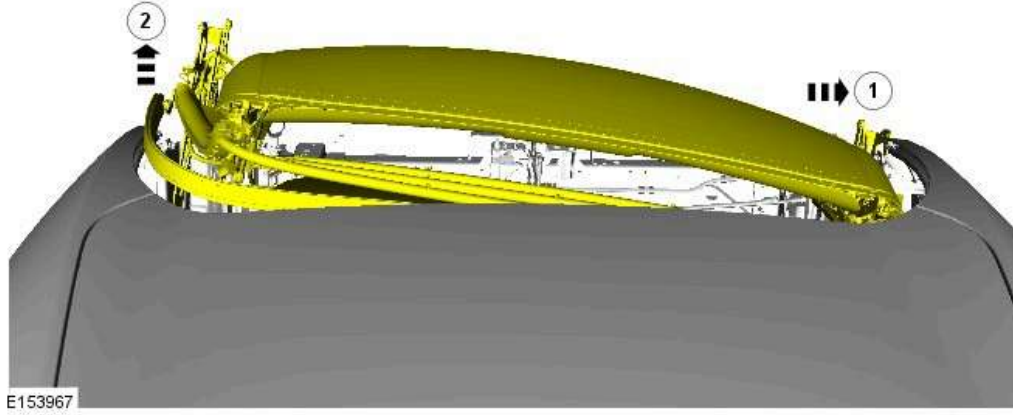

With assistance, remove the folding top assembly.

30.

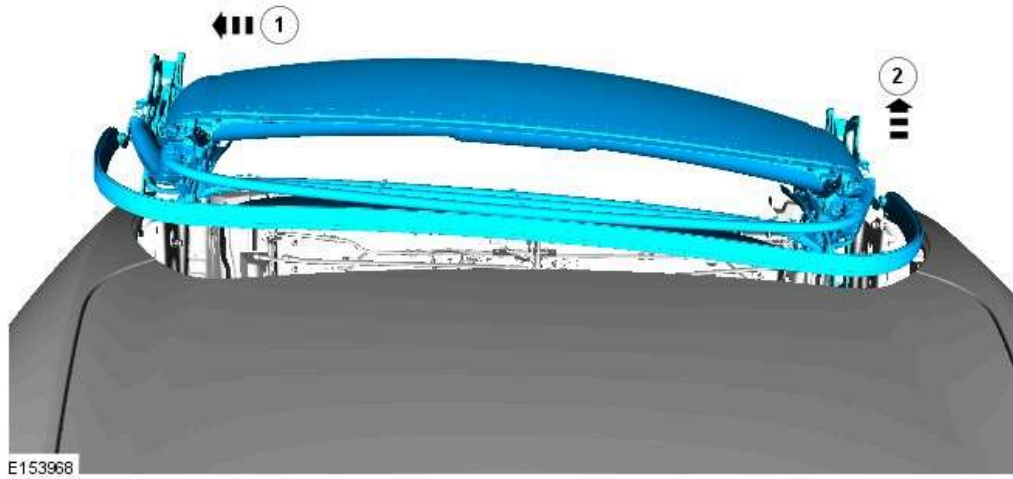

With assistance, remove the folding top assembly.

INSTALLATION

1. Remove the protective tape.

2. Make sure that all traces of the old sealant are removed from the mating surfaces.

- 3.

NOTE:

This step is only required if the component has been removed access.

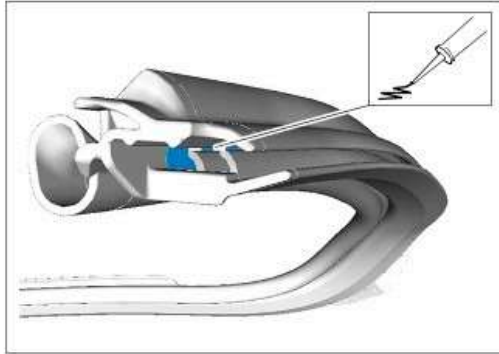

E154241

Apply silicone rubber sealant or equivalent meeting Jaguar specification.

4.

NOTE:

This step is only required if a new component is installed.

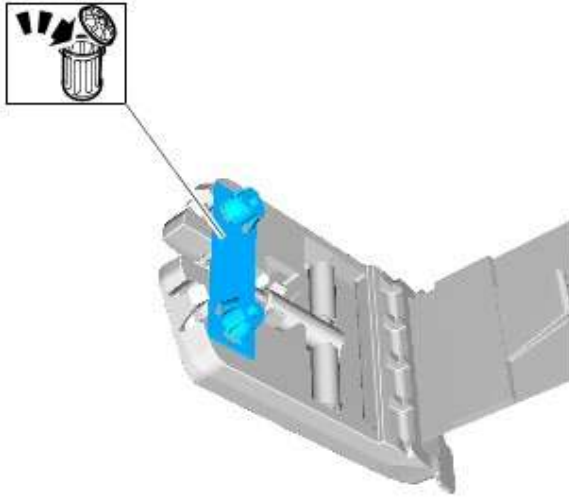

E154011

5.

NOTE:

Repeat the procedure for the other side.

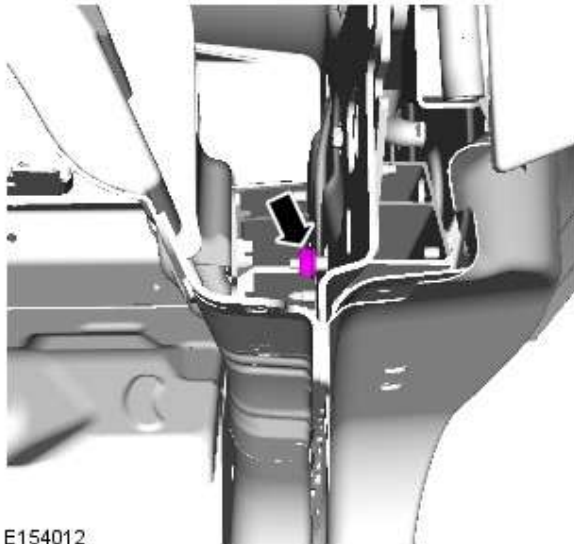

E154012

Install the nut but do not fully tighten at this stage.

6. Apply the protective tape to the body aperture.

7.

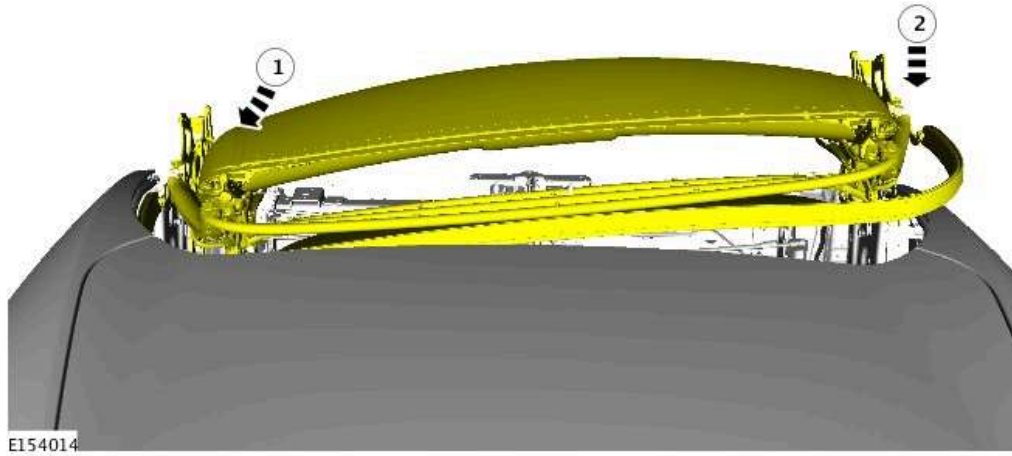

With assistance, install the folding top assembly.

8.

NOTE:

Repeat the procedure for the other side.

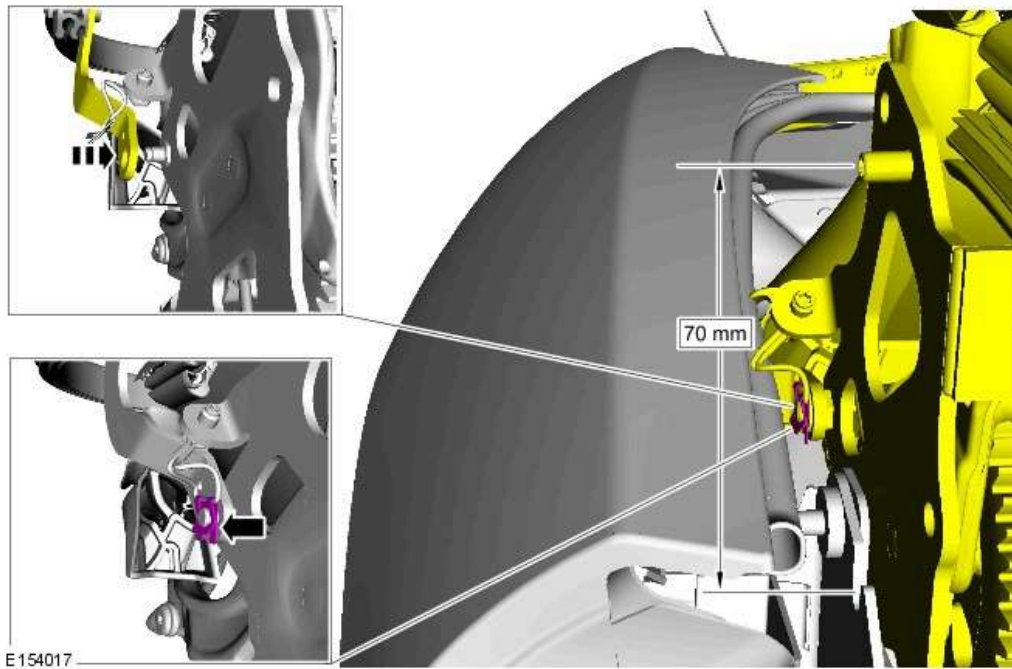

9.

NOTE:

Repeat the procedure for the other side.

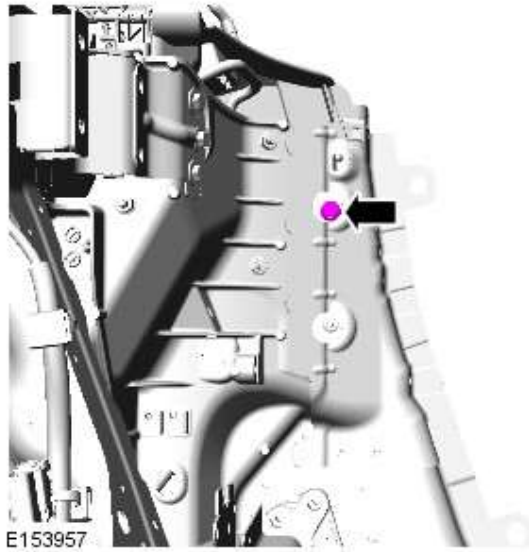

Fit the bolt but do not fully tighten at this stage.

10.

NOTE:

Repeat the procedure for the other side.

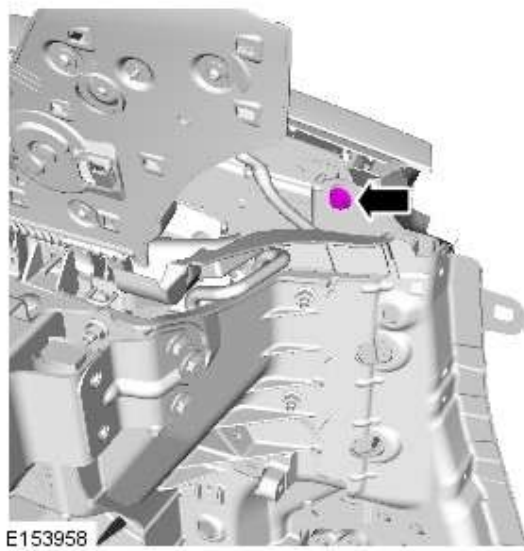

Fit the bolt but do not fully tighten at this stage.

11.

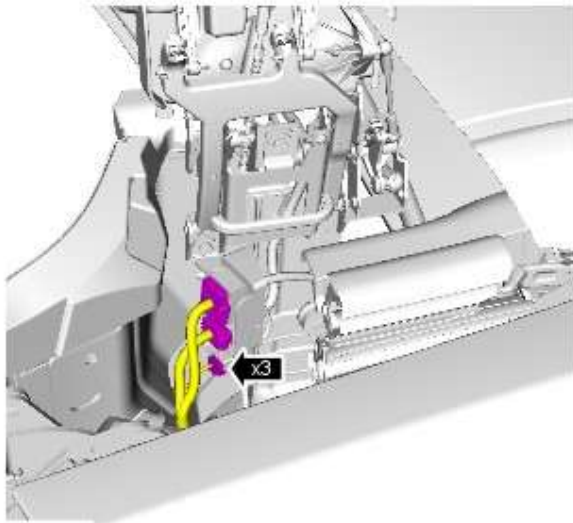

E153961

12.

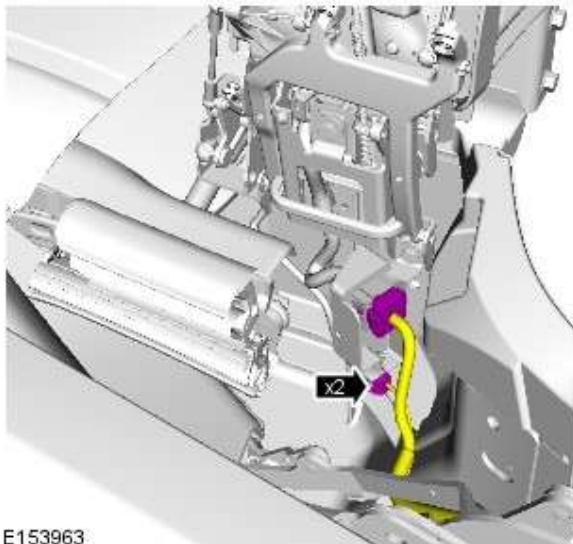

E153963

13.

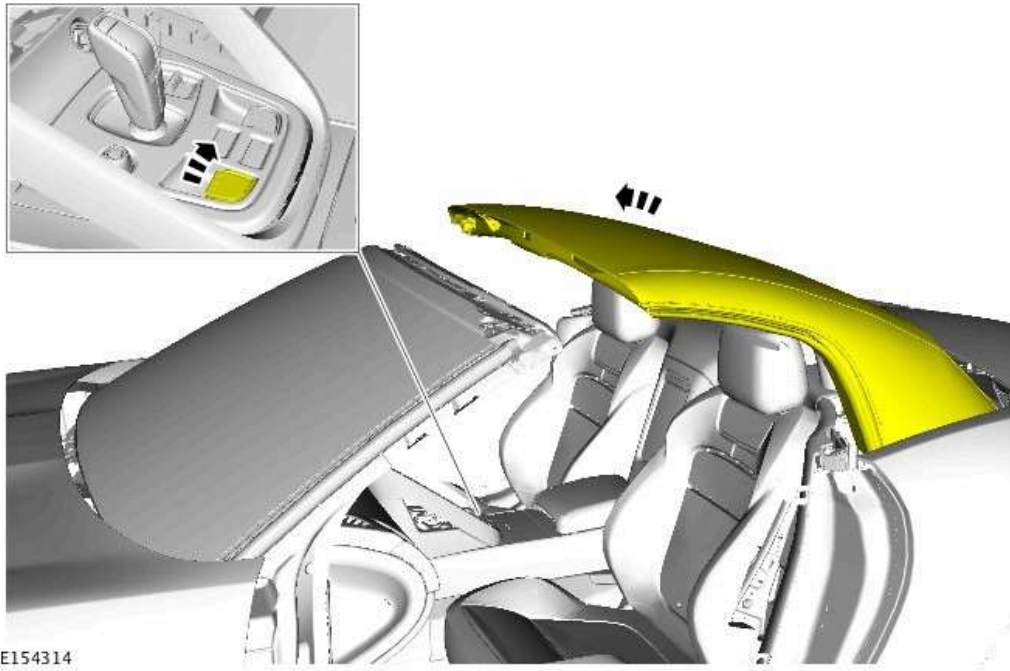

Close the folding top to the position shown.

14.

NOTE:

The procedure must be carried out on both sides.

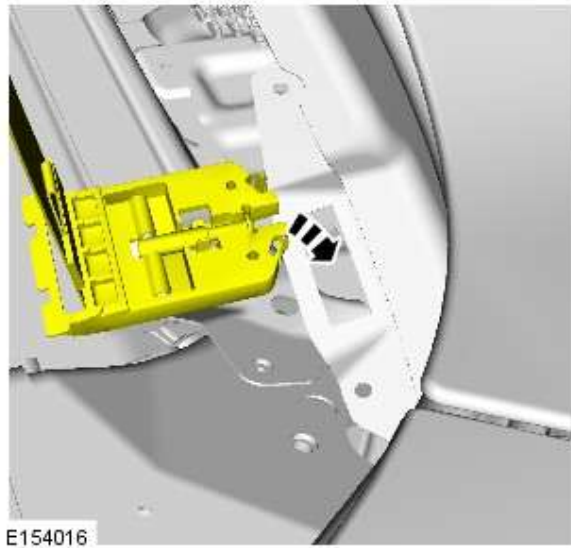

15.

NOTE:

The procedure must be carried out on both sides.

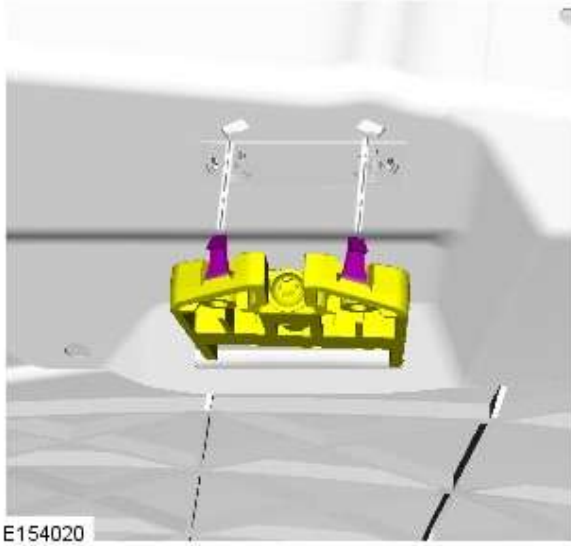

16.

NOTE:

The procedure must be carried out on both sides.



Install the Torx bolts, but do not tighten fully at this stage.

17.

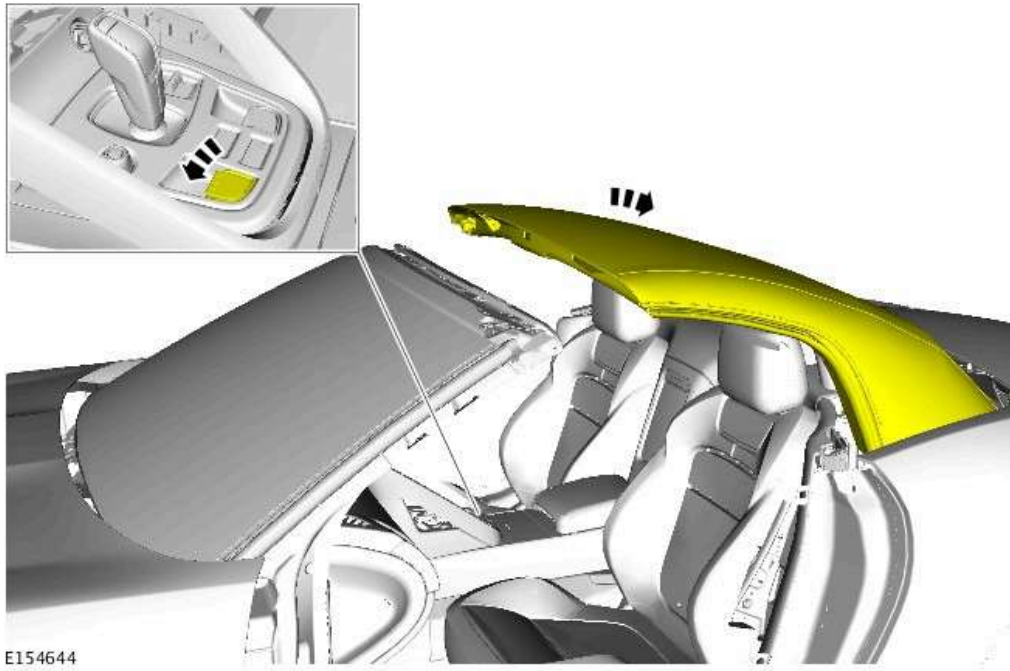

Operate the folding top to a fully open position.

18.

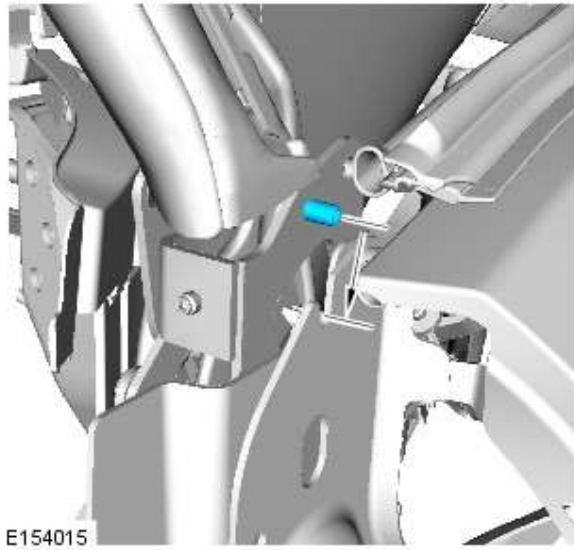

Make sure folding top assembly is correctly located on fixing brackets.

19.

NOTE:

Repeat the procedure for the other side.

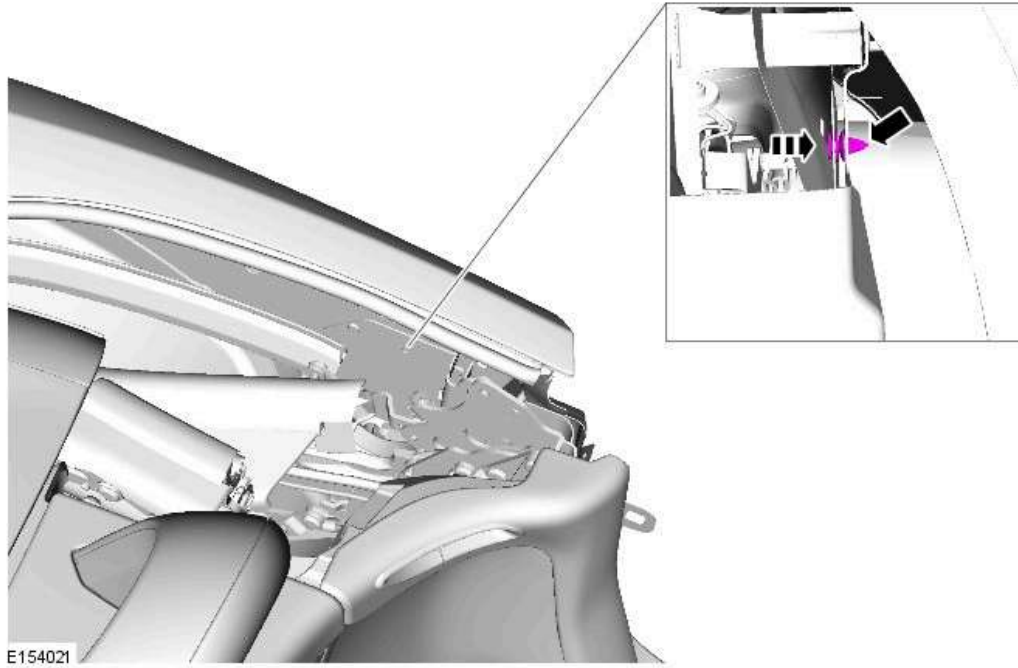

20.

NOTE:

Repeat the procedure for the other side.

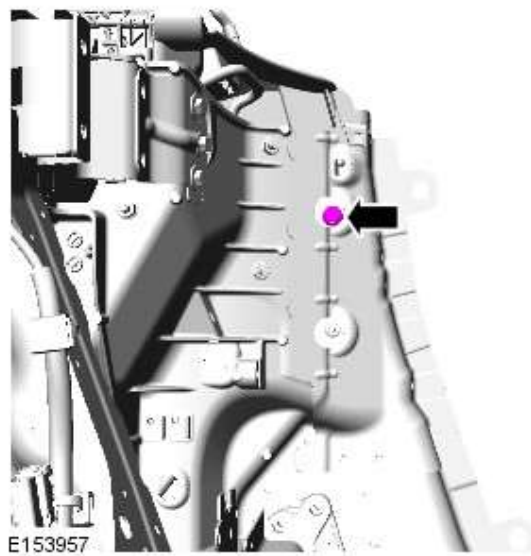

Torque: **25Nm**

21.

NOTE:

Repeat the procedure for the other side.

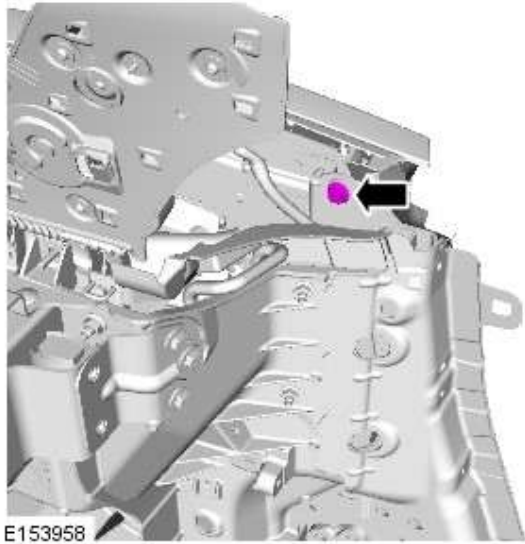

Torque: 25Nm

22.

NOTE:

Repeat the procedure for the other side.

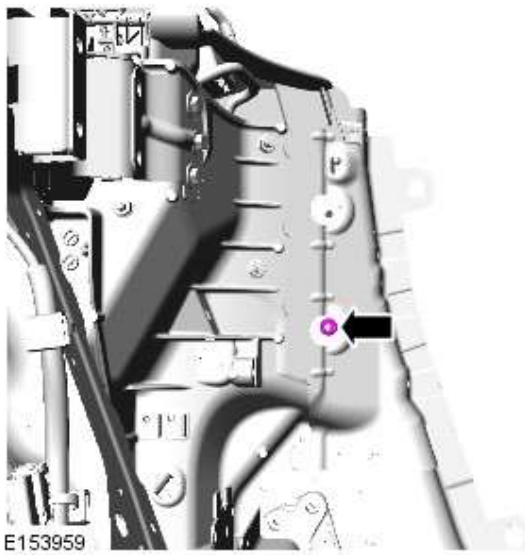

Torque: 25Nm

23. Remove the protective tape.

24.

NOTE:

The procedure must be carried out on both sides.

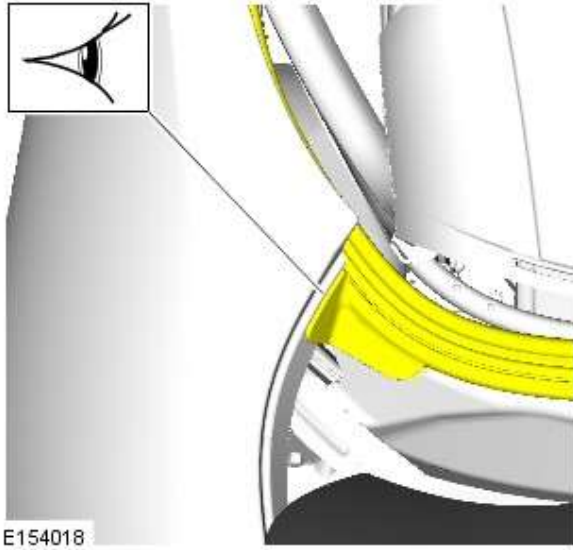

25.

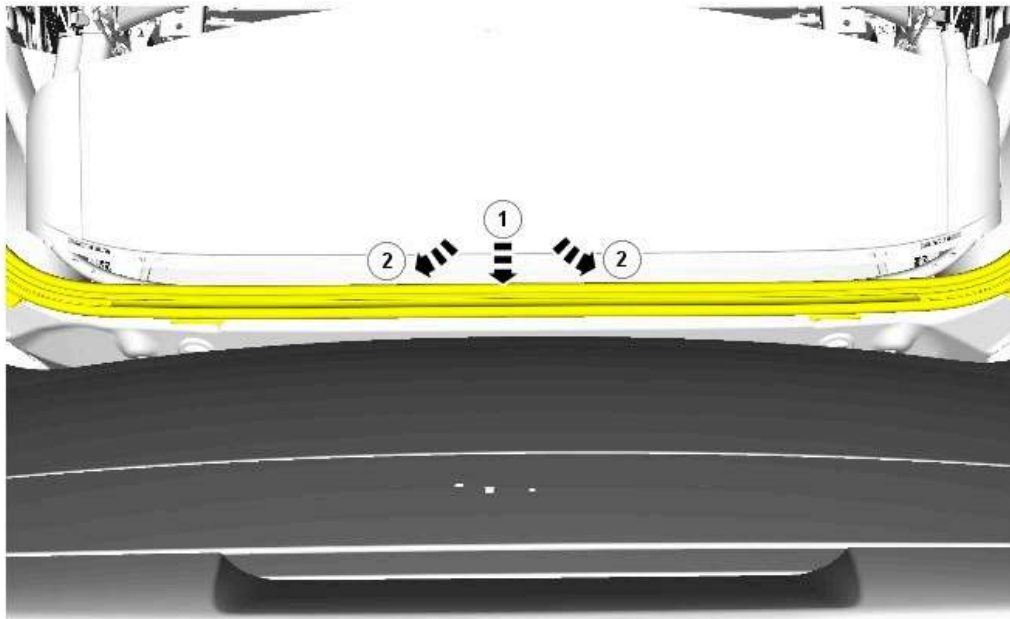

26.

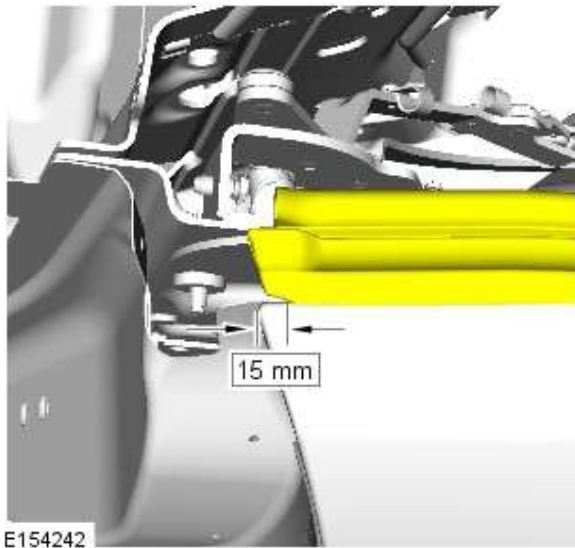

27.

NOTE:

Repeat the procedure for the other side.

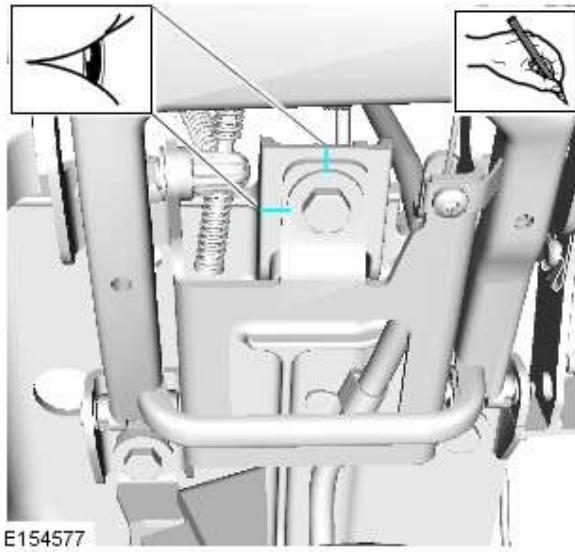

28.

NOTE:

Repeat the procedure for the other side.

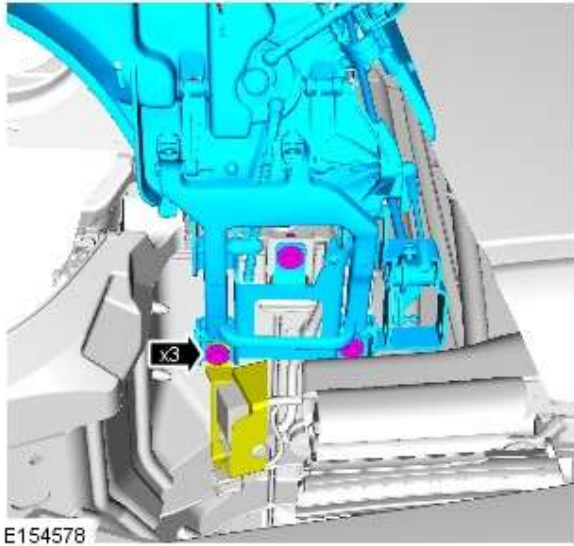

E154578

Torque: 11Nm

29.

NOTE:

Repeat the procedure for the other side.

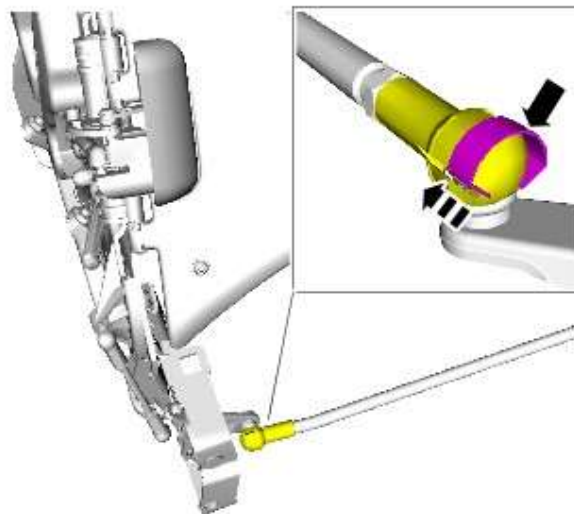

E154576

30.

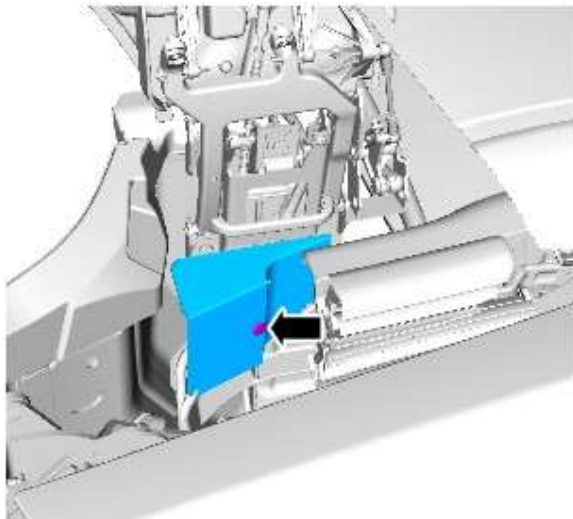

E153960

31.

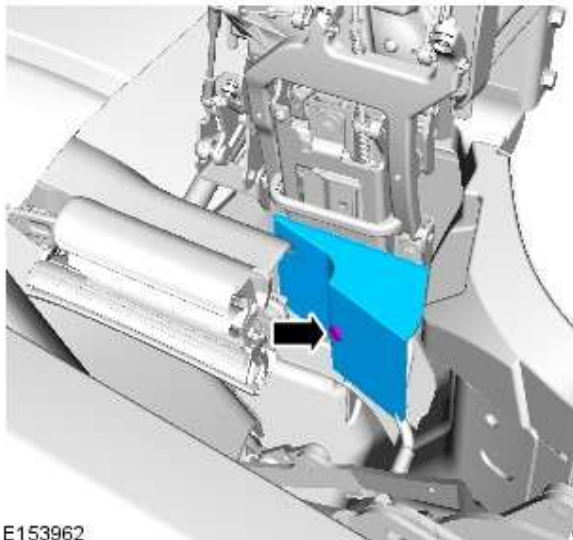

E153962

32.

NOTE:

The procedure must be carried out on both sides.

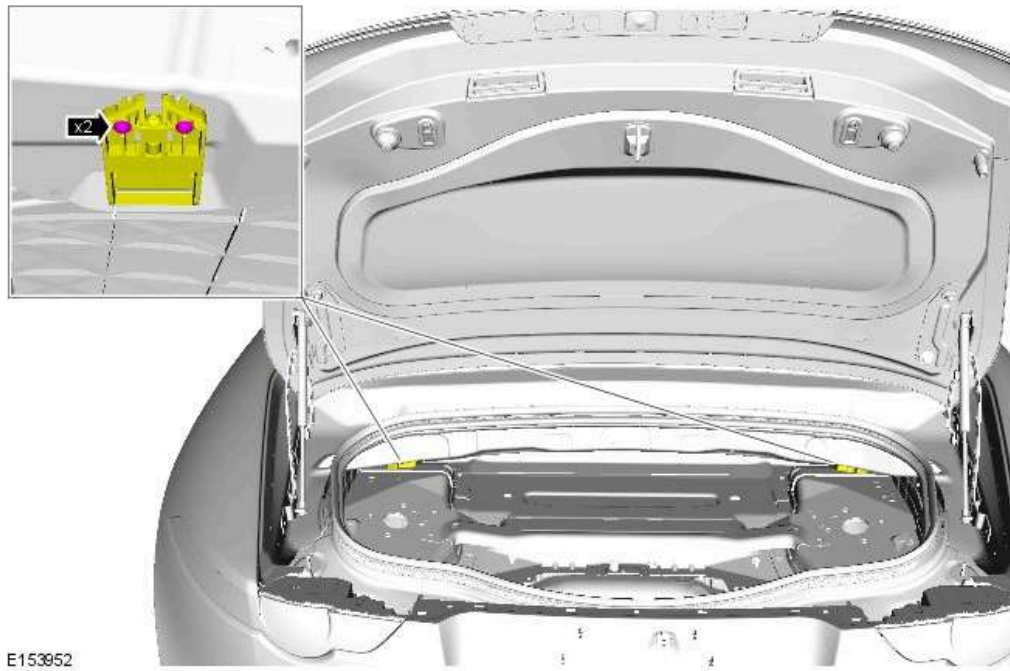

Torque: 11Nm

33. Operate the folding top fully in each direction.

34.

CAUTION:

Adjustment of the folding top should be an equal amount of turns on the left and right adjuster screws, to prevent twisting. The adjustment should not exceed 3 complete revolutions in a clockwise or counter-clockwise direction.

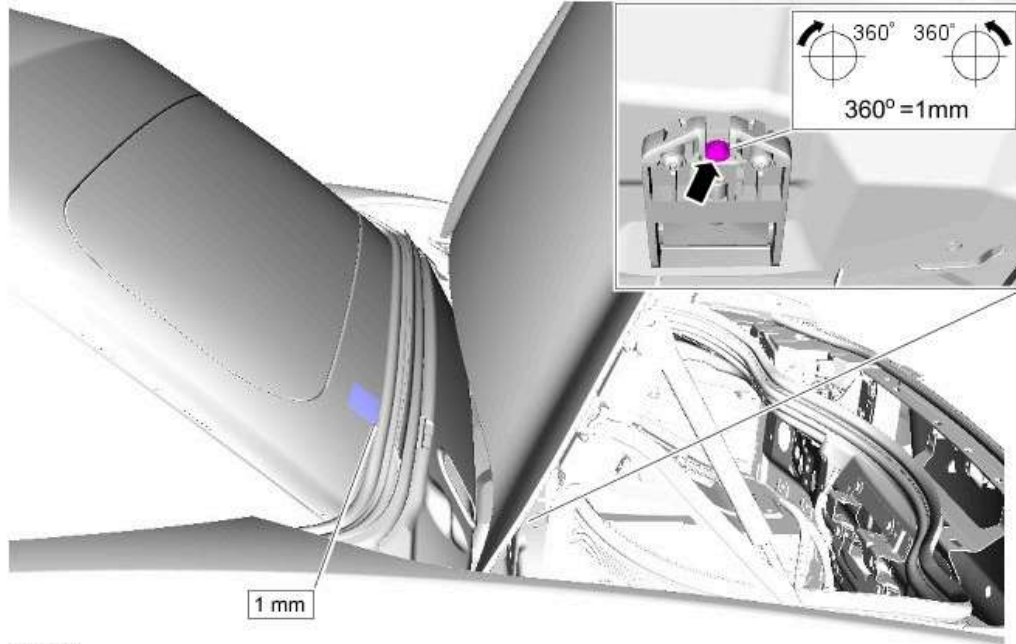

- Check the tension of the folding top.
- Adjust tension to touching or 1mm compression between aperture seal and top.
- After each 1mm adjustment, release the folding top from the latched position, re-latch and re-check the tension.

35.

NOTE:

Repeat the procedure for the other side.

Refer to: [Loadspace Trim Panel - Convertible](#) (501-05 Interior Trim and Ornamentation, Removal and Installation).

36.

NOTE:

Repeat the procedure for the other side.

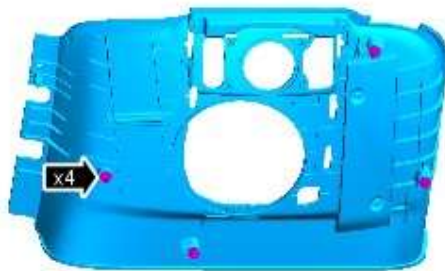
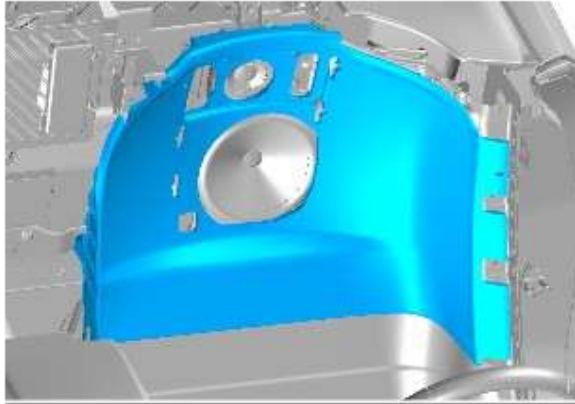

E152941

37.

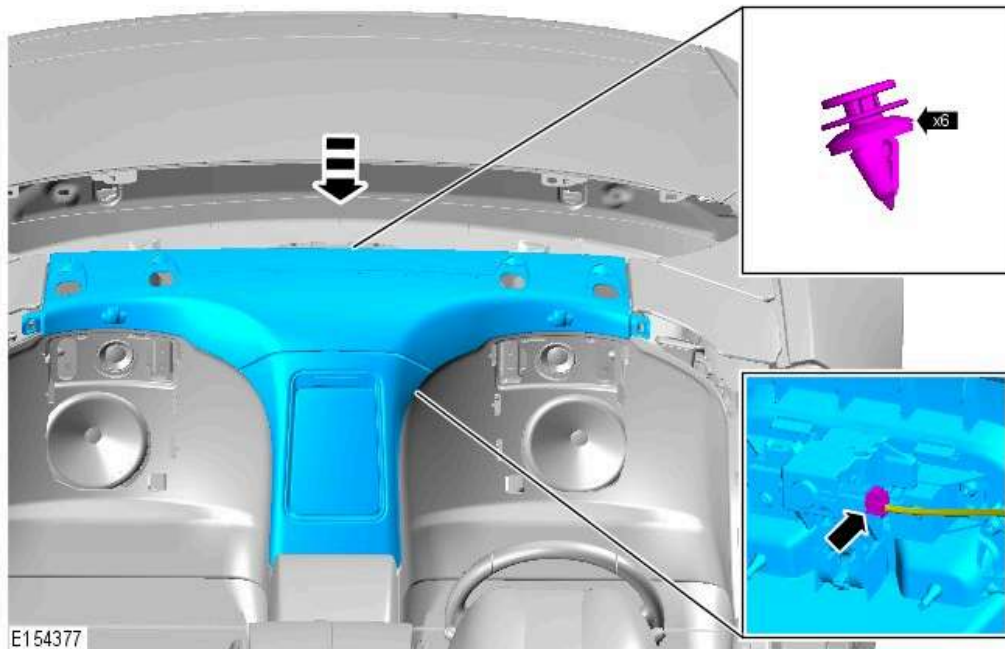

E154377

38.

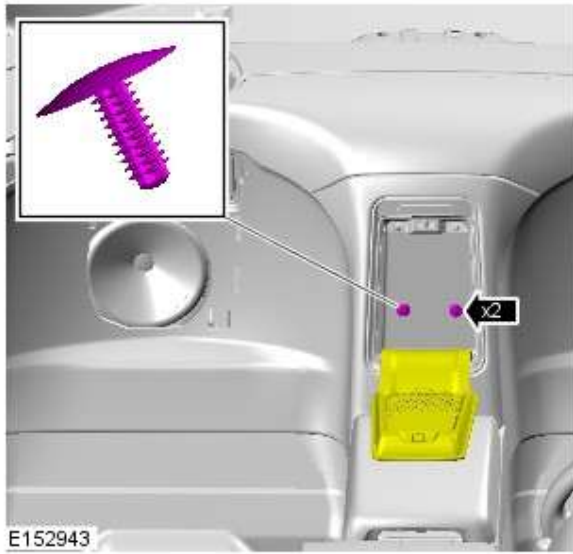

39.

NOTE:

Repeat the procedure for the other side.

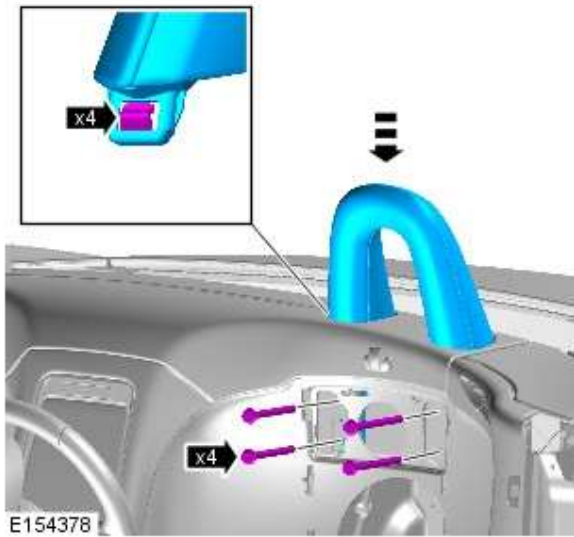

Torque: **45Nm**

40.

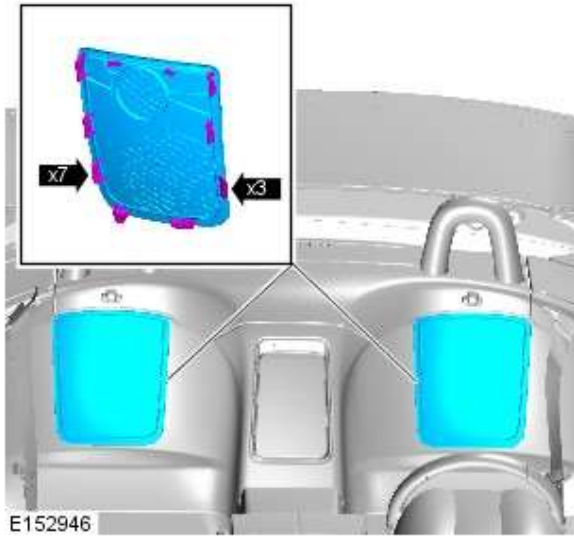

41.

NOTE:

Repeat the procedure for the other side.



42.

NOTE:

Repeat the procedure for the other side.

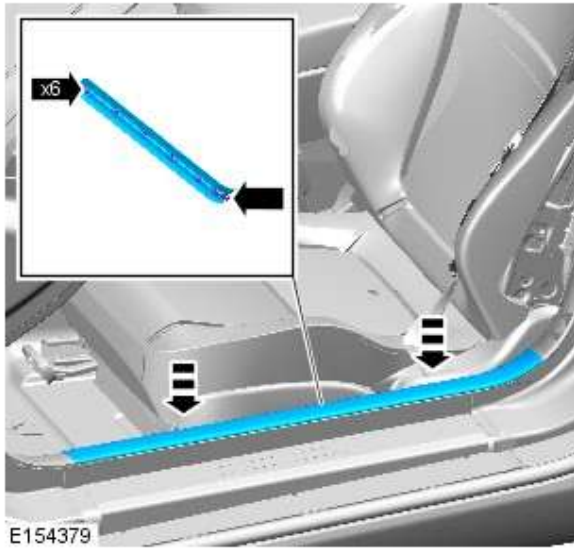

43.

NOTE:

Repeat the procedure for the other side.

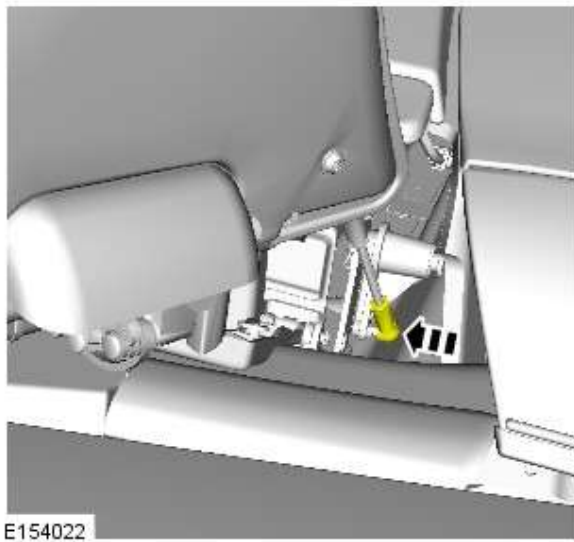

←←.

NOTE:

Repeat the procedure for the other side.

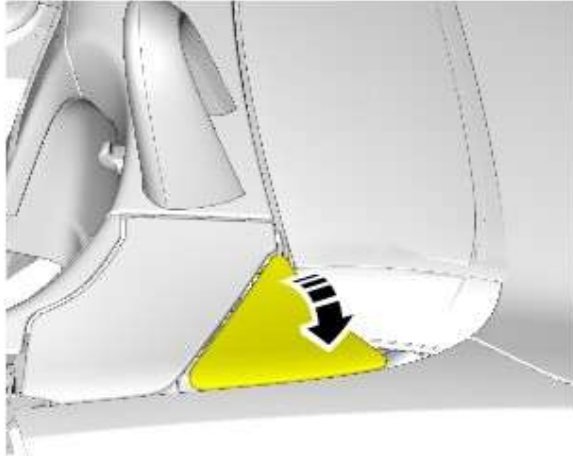

E154243

anFsb2lzaW87MjAyN0wNC0wOVQwMjowMT0xNC43MjFaOzczLjQ2LjwMS4xMTc7