

Vibration When Braking –  
Brembo Brakes Disc Thickness Variation –  
Diagnosis/Repair

MODEL 2003-05 MY  
S-TYPE R

VIN M44998-N52047

**Issue:**

A customer may report a concern of, or a recurrence of vibration/shudder while braking, despite an earlier occurrence of the problem being resolved with replacement brake discs and brake linings.

**Cause:**

Vibration/shudder while braking is not necessarily caused by brake disc run-out (also referred to as warped discs, or out-of-roundness of the discs). It can also be caused by low levels of disc thickness variation (DTV) being present around the contact area of the brake disc. DTV is caused when a vehicle with moderate levels of brake disc run-out, drives many miles with very little braking activity, such as on a highway or freeway. The installation angle of the replacement discs and the rubbing of the brake pad on the high areas of the rotating brake disc when the brakes are not applied, cause the DTV. Refer to illustration 1.

**DISC THICKNESS VARIATION (DTV)**

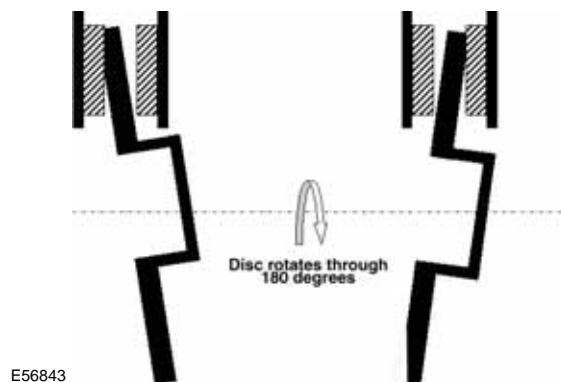

ILLUSTRATION 1

**NOTE: THE INFORMATION IN TECHNICAL BULLETINS IS INTENDED FOR USE BY TRAINED, PROFESSIONAL TECHNICIANS WITH THE KNOWLEDGE, TOOLS, AND EQUIPMENT TO DO THE JOB PROPERLY AND SAFELY. IT INFORMS THESE TECHNICIANS OF CONDITIONS THAT MAY OCCUR ON SOME VEHICLES, OR PROVIDES INFORMATION THAT COULD ASSIST IN PROPER VEHICLE SERVICE. THE PROCEDURES SHOULD NOT BE PERFORMED BY "DO-IT-YOURSELFERS." DO NOT ASSUME THAT A CONDITION DESCRIBED AFFECTS YOUR CAR. CONTACT A JAGUAR DEALER TO DETERMINE WHETHER THE BULLETIN APPLIES TO YOUR VEHICLE.**

This incorrect installation angle may be due to contamination between the brake disc mounting surface and the drive flange, or a combination of drive flange run-out and brake disc run-out. Refer to illustration 2.

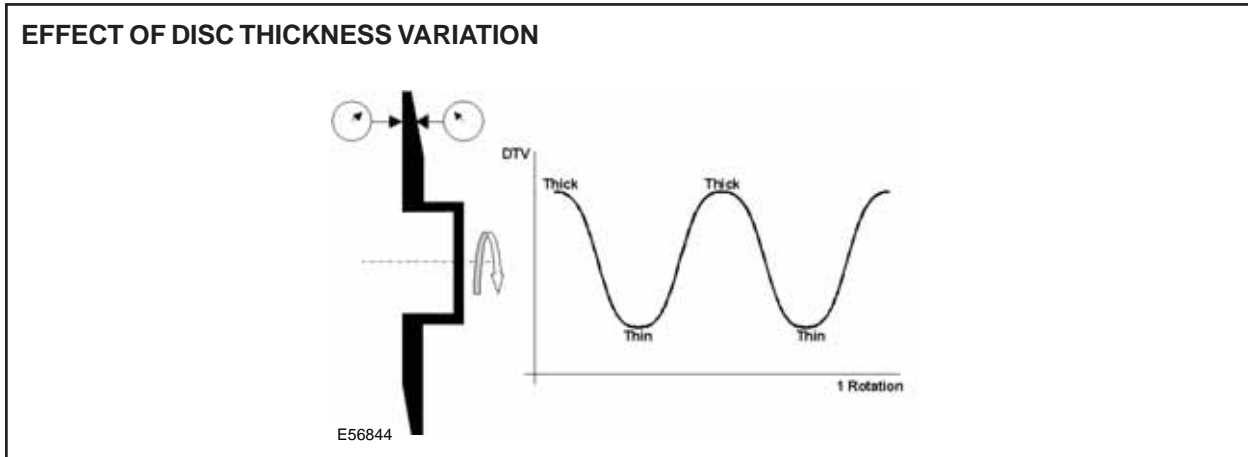

ILLUSTRATION 2

**Note:** It is essential to measure the disc run-out for diagnosis of the concern and when new discs are installed to prevent recurrence of the problem.

**Action:**

Should a customer express concern regarding the above condition, refer to the Service Procedure detailed in this Bulletin to ensure that the risk of recurrence is minimized.

**SERVICE PROCEDURE**

**Note:** Ensure that the road wheels are correctly balanced before preceding with this bulletin.

**Note:** The Warranty Brake Disc Renewal - Policy, should be observed. For additional information, refer to TSB XJ206-05.

When replacing discs due to vibration/shudder while braking, use the following procedure for each side of the vehicle:

**Note:** If the vehicle has returned for the same defect of vibration/shudder during braking after previously having a new set of discs installed, then install a new set of discs by completing procedure below and install new front lower suspension arms, part number C2C 26835 on both sides of the vehicle, which reduce the vehicles sensitivity to brake vibration/shudder. For additional information, refer to Global Technical Reference (GTR) XJ Range Workshop Manual Section 204-01, Front Lower Arm.

**Note:** It is not necessary to replace brake pads when completing this procedure unless the lining minimum thickness is below specified tolerance of 3 mm (0.118 in).

**⚠ Caution:** Do not allow the brake caliper to be suspended by the flexible hose.

1. Remove the brake caliper and secure aside. For additional information, refer to Global Technical Reference (GTR) XJ Range Workshop Manual Section 206-03, Braking System - Front Brake Disc - Brake Caliper - Vehicles With: High Performance Brakes, VIN Range: G00442->G45704.
2. Remove the brake disc. For additional information, refer to Global Technical Reference (GTR) XJ Range Workshop Manual Section 206-03, Brake Disc - Vehicles With: High Performance Brakes.
3. Before installing the replacement disc, thoroughly clean the inside of the disc mounting hub and the surface of the drive flange.

**Note:** Do not overtighten the wheel nuts as it will become impossible to measure the disc run-out accurately.

4. Install the new brake disc to the drive flange and secure with at least three wheel nuts, tightened to a maximum of 4 Nm.
5. Mount a dial test indicator (DTI) to the inboard side of the vertical link using the caliper assembly lower bolt hole (Illustration 3).

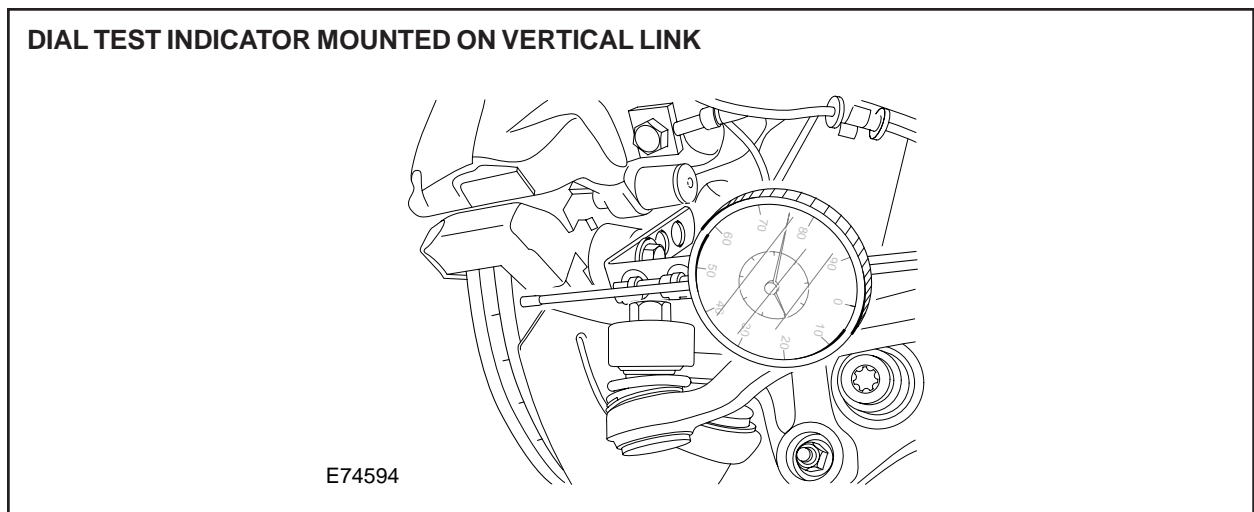

ILLUSTRATION 3

6. Position the DTI probe 5 mm in from outer edge of disc.
7. Measure the disc run-out with one rotation of the disc.
  - If the measured run-out is less than 0.04 mm then go to step 20.
  - If the measured run-out is greater than 0.04 mm then go to step 8.
8. Remove the wheel nuts from the wheel studs.

9. Remove the disc from the drive flange, rotate clockwise through 180°, reposition on the drive flange and secure as previously.
10. Position the DTI probe 5 mm in from outer edge of disc.
11. Measure the disc run-out with one rotation of the disc.
  - If the measured run-out is equal to the first measurement taken in step 7, then go to step 12.
  - If the measured run-out is less than the first measurement taken in step 7, but still greater than 0.04 mm then go to step 30.
  - If the measured run-out is less than 0.04 mm then go to step 20.
12. Remove the wheel nuts from the wheel studs.
13. Remove the brake disc from the flange, rotate clockwise through 90°, reposition on the drive flange and secure as previously.
14. Position DTI probe 5 mm in from the outer edge of the disc.
15. Measure the disc run-out with one rotation of the disc.
  - If the measured run-out is equal to the second measurement taken in step 11, then go to step 30.
  - If the measured run-out is greater than the second measurement taken in step 11, then go to step 16.
  - If the measured run-out is less than the second measurement taken in step 11, but still greater than 0.04 mm then go to step 30.
  - If the measured run-out is less than 0.04 mm then go to step 20.
16. Remove the wheel nuts from the wheel studs.
17. Remove the disc from the drive flange, rotate clockwise through 180°, reposition on the drive flange and secure as previously.
18. Position DTI probe 5 mm in from the outer edge of the disc.
19. Measure the disc run-out with one rotation of the disc.
  - If the measured run-out is less than the third measurement taken in step 15, but greater than 0.04 mm then go to step 30.
  - If the measured run-out is less than 0.04 mm then go to step 20.
20. Remove the wheel nuts from the wheel studs.
21. Remove the DTI from the vertical link.
22. Refit the brake caliper, only tightening the upper mounting bolt. For additional information, refer to Global Technical Reference (GTR) XJ Range Workshop Manual Section 206-03, Braking System - Front Brake Disc - Brake Caliper - Vehicles With: High Performance Brakes, VIN Range: G00442->G45704.
23. Clean the mating surfaces on the brake disc and the road wheel with brake cleaner to ensure they are free from debris.

**Note:** Torque the wheels in the order illustrated.

24. Refit the road wheel and tighten nuts to 128 Nm (94 lb-ft) Illustration 4.

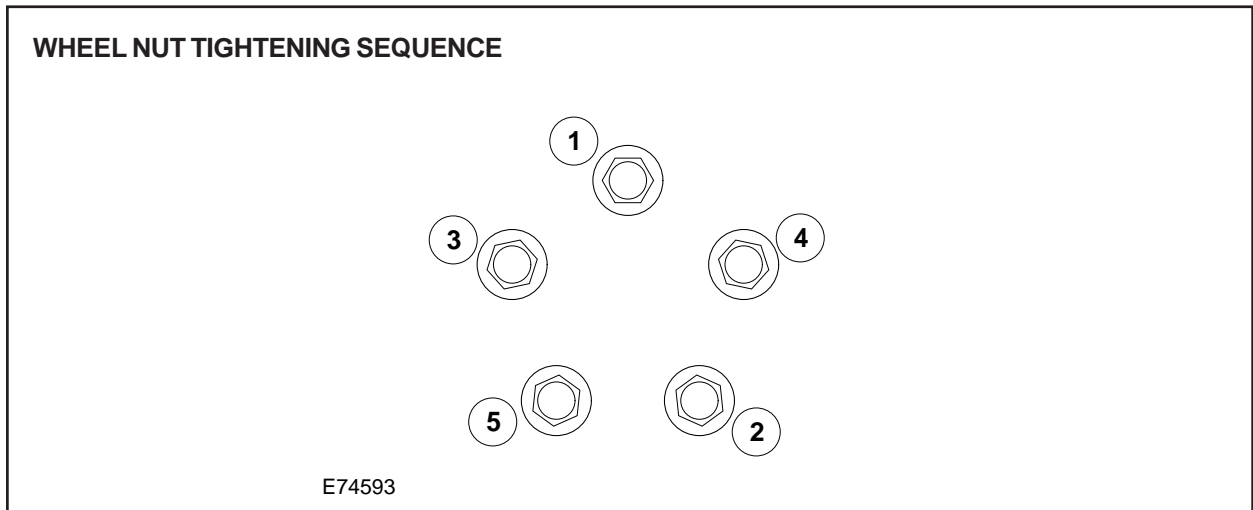

ILLUSTRATION 4

25. Mount the DTI to the inboard side of the vertical link using caliper assembly lower bolt hole.
26. Position the DTI probe between the caliper and the dirt-shield, 5 mm in from outer edge of disc.
27. Measure the disc run-out with one rotation of the disc.
- If the measured run-out is less than 0.05 mm then go to step 28.
  - If the measured run-out is greater than 0.05 mm then go to step 30.
28. Remove the DTI from the vertical link.
29. Refit caliper lower mounting bolt and tighten to the specified torque. For additional information, refer to Global Technical Reference (GTR) XJ Range Workshop Manual Section 206-03, Braking System - Front Brake Disc - Brake Caliper - Vehicles With: High Performance Brakes, VIN Range: G00442->G45704.
30. In all instances where the run-out specification cannot be achieved, refer to the Technical Help Line for further assistance.
31. Repeat disc location procedure for the other side.
32. Depress the brake pedal several times to set the brake pads.

## Global Technical Reference (GTR) Workshop Manual Information:

Dealer access: <https://hub.franchise.jaguar.com>

Internet access: <http://www.jaguartechno.com>

### Parts Information:

<u>DESCRIPTION</u>	<u>PART NUMBER</u>	<u>QTY</u>
Lower suspension arm	C2C 26835	2
Brake disc set	C2C 8355	1

### Warranty Information:

Warranty claims should be submitted quoting the information found in the table below. This will result in payment of the stated time and, where applicable parts/miscellaneous expense codes as listed.

Description	SRO	Time	Causal Part Number
Front lower arm - vehicle set - renew	60.35.60	1.9 hrs.	C2C 8355
Install disc to attain minimum run-out	70.91.32	1.3 hrs.	C2C 8355

**Note:** Repair procedures are under constant review, and therefore repair times are subject to change. The times quoted here must be taken as guidance only. Always refer to DDW to obtain the latest repair time.