

Jaguar S Type 3.0 V6 Auto 2000MY (UK RHD)

Opening the bonnet (Hood) through a mesh grill after the small cross over cable has failed. (Part number XR8001957) Number 8 in the drawing.

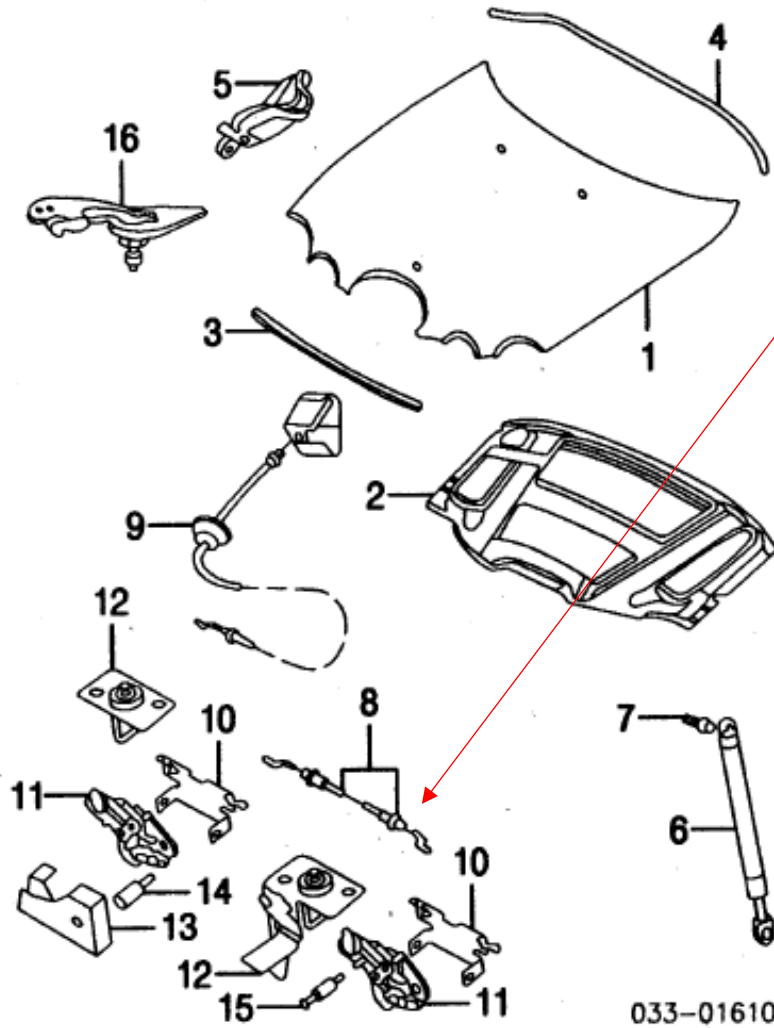

I used a electricians cable puller, which has a flexible end adaptor. On the end of this I put in a long small gauge nail which was then bent into a hook.

On mine, a section of one of angled end pieces had broken off, and the cable was no longer pulling.



Picture showing the end of the cable puller with the bent nail in the end.



Cable Puller pushed through the mesh grill

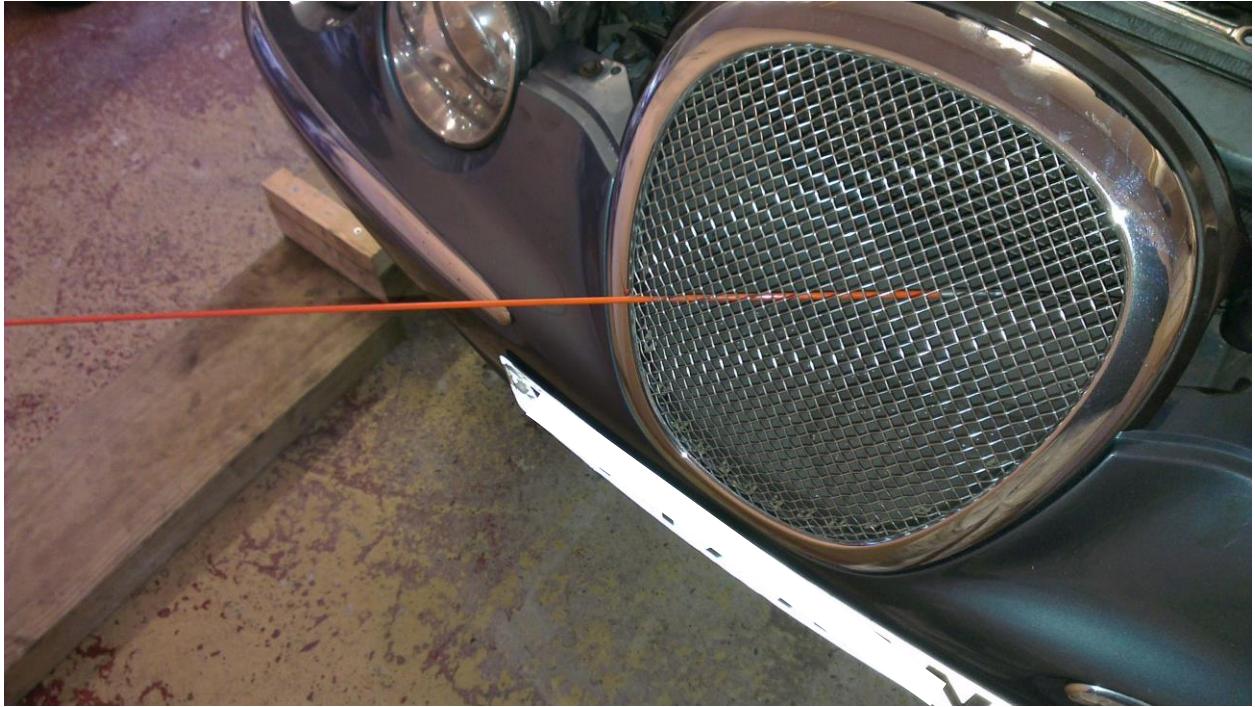

Hooked nail pulling on the latch release arm

