

## Secondary Timing Chain RH 12.65.68

### Removal

1. Remove the right-hand bank primary timing chain. For additional information, refer to <<Timing Chain—Primary, Right-Hand Bank>>

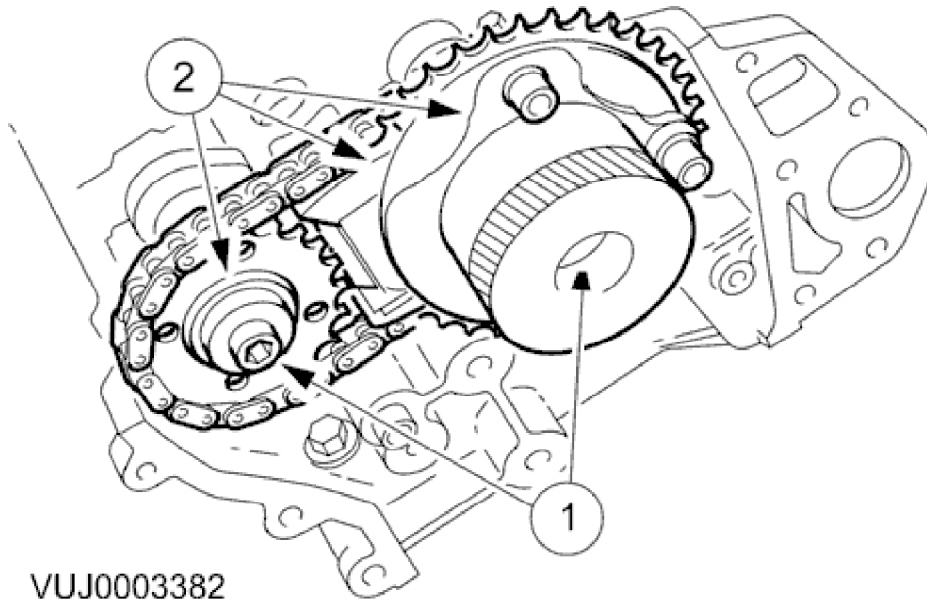

2. Remove the VVT unit and exhaust camshaft sprocket.
  1. Remove the VVT unit and exhaust camshaft sprocket bolts.
  2. Remove the VVT unit, exhaust camshaft sprocket and secondary chain as an assembly (release the chain from the tensioner which is still attached to the cylinder head).
- Remove the secondary chain from the VVT unit and the sprocket.

### Installation

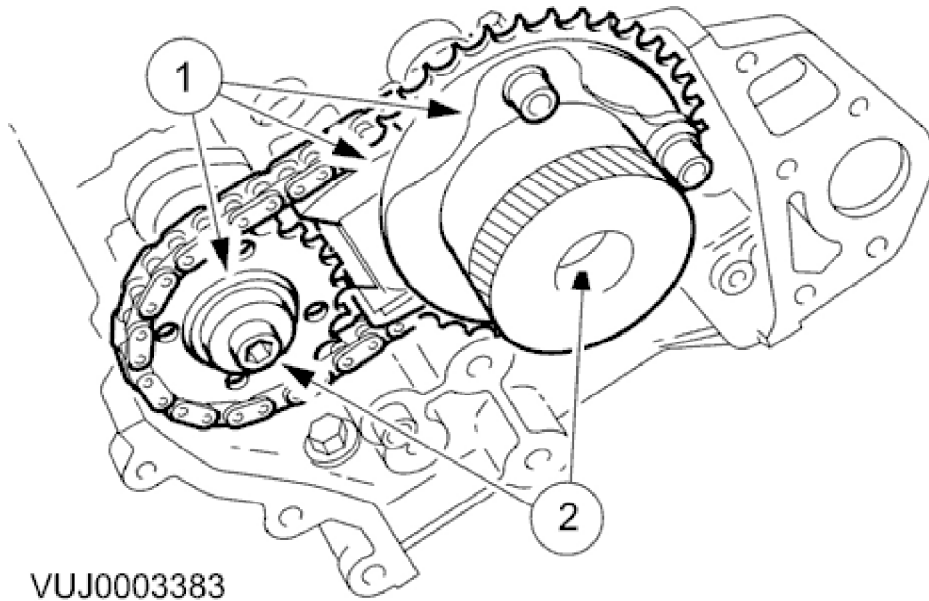

VUJ0003383

1. Install the secondary chain assembly.

- Assemble the VVT unit, the exhaust camshaft sprocket and the secondary chain.

1. Install the secondary chain assembly to the camshafts with the chain correctly positioned over the tensioner; VVT unit to the intake and the sprocket to the exhaust.
2. Install the VVT unit and sprocket bolts, do not fully tighten.

2. Install the right-hand bank primary timing chain. For additional information, refer to <<**Timing Chain—Primary, Right-Hand Bank**>>