

2001 S-TYPE - Engine - 4.0L - 303-01B

Primary Timing Chain RH 12.65.66

Special Service tools

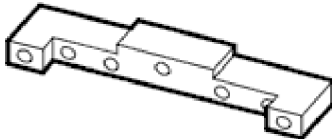

303-530
Camshaft setting
303-530



DWST021
Timing chain tensioning tool
303-532

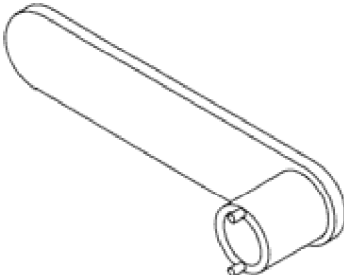

303-654
Variable camshaft timing oil control unit setting tool
303-654

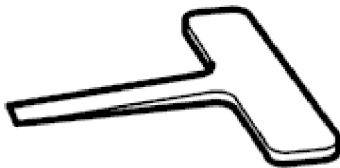

303533
Wedges, primary chain
303-533

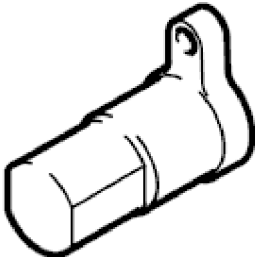

DWST032
Crankshaft setting, main tool
303-645

Removal

- 1. Remove the engine front cover. <<Engine Front Cover>>

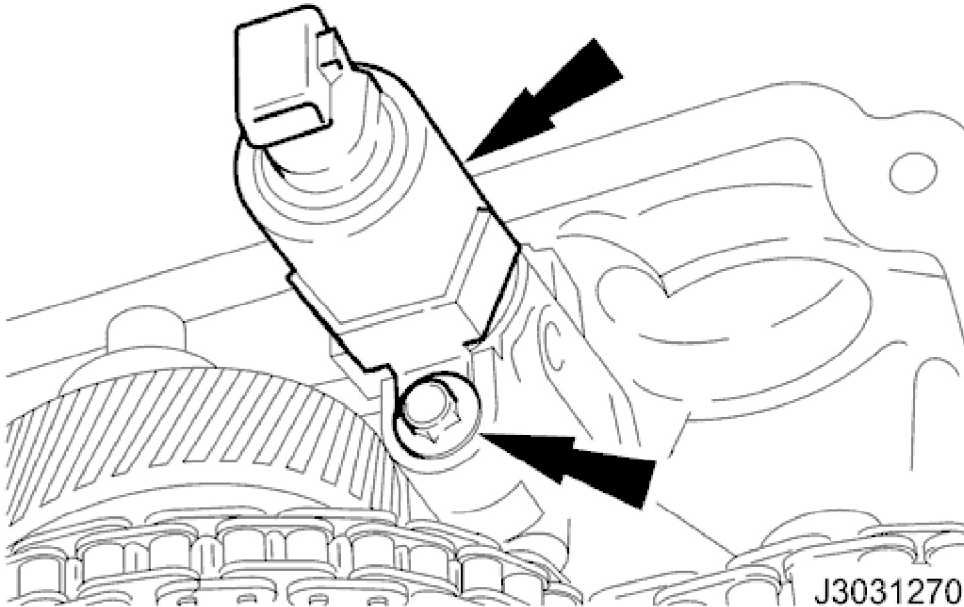

- 2. Remove the VVT solenoid.

2001 S-TYPE - Engine - 4.0L - 303-01B

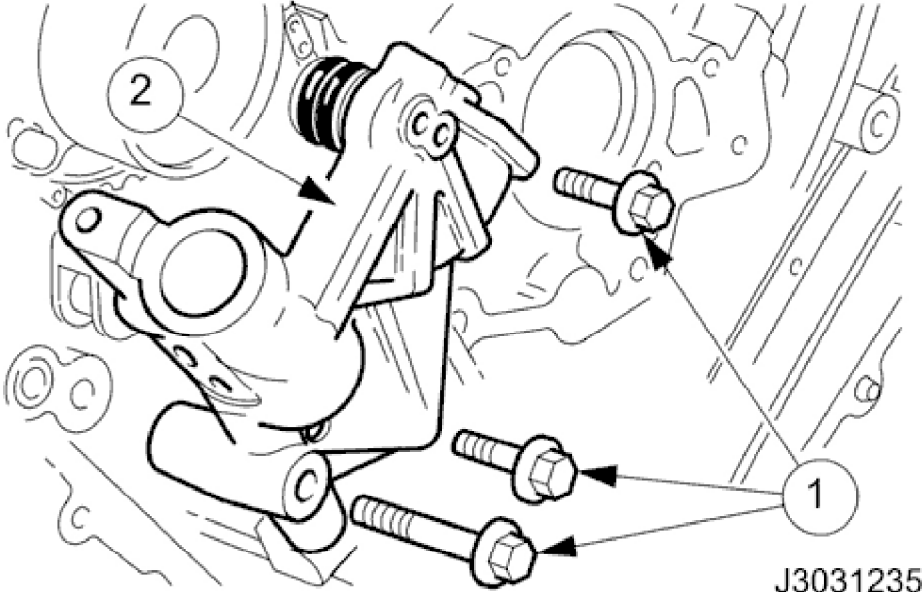

- 3. Remove the VVT bush carrier from the right-hand bank.
 - 1. Remove the bush carrier retaining bolts.
 - 2. Release the carrier from the two ring dowels and remove it.

4. Raise and support the vehicle. <<100-02>>[Lifting]

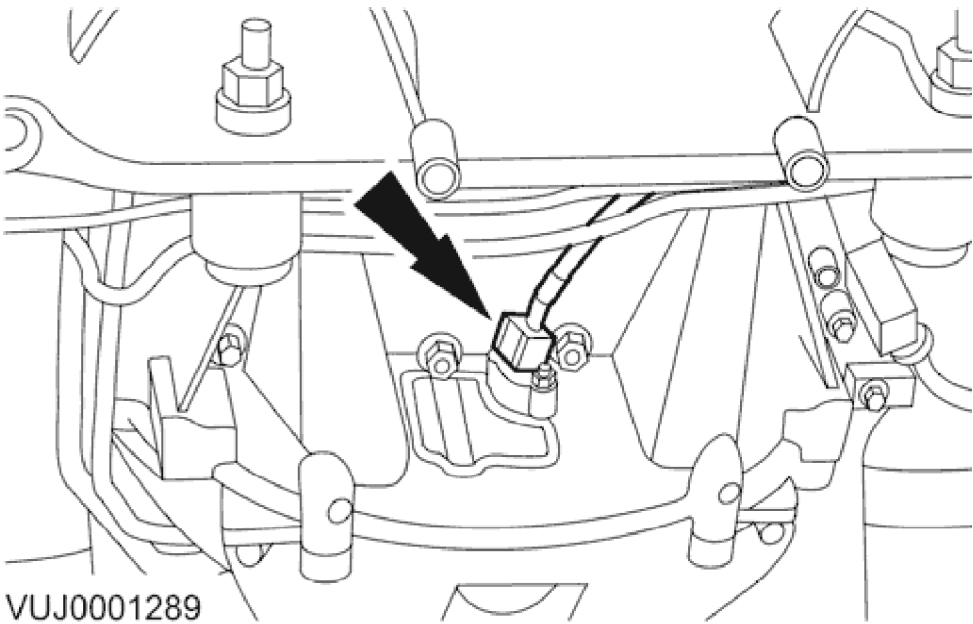

5. Disconnect the crankshaft position sensor electrical connector.

2001 S-TYPE - Engine - 4.0L - 303-01B

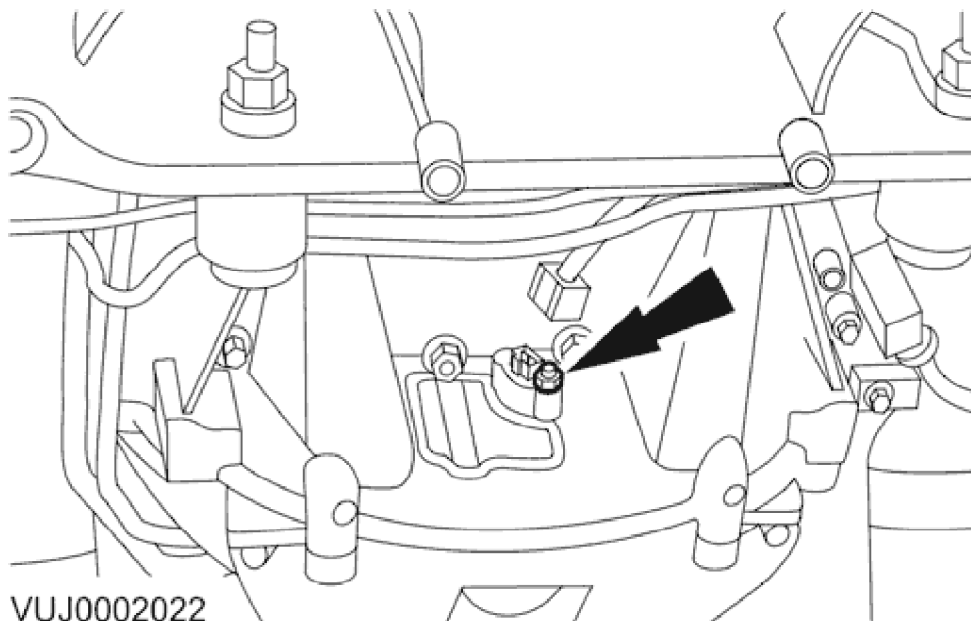

VUJ0002022

6. Remove the crankshaft position sensor.

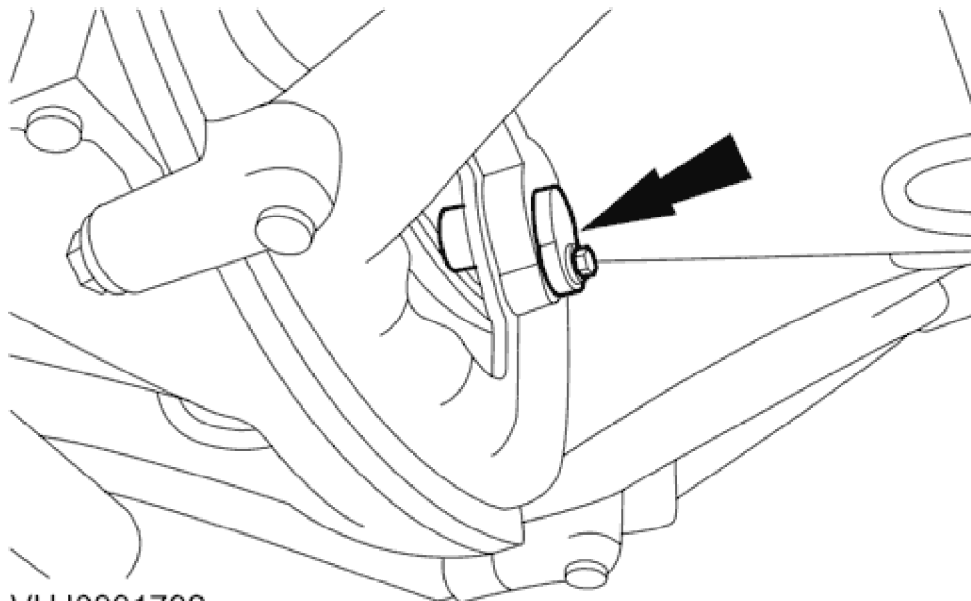

VUJ0001792

7. Install the crankshaft setting peg 303-645 to the crankshaft position sensor location.
- Install the crankshaft setting peg 303-645.
 - Position the crankshaft so that the setting peg engages fully into the timing slot.
 - Install the setting peg bolt.

2001 S-TYPE - Engine - 4.0L - 303-01B

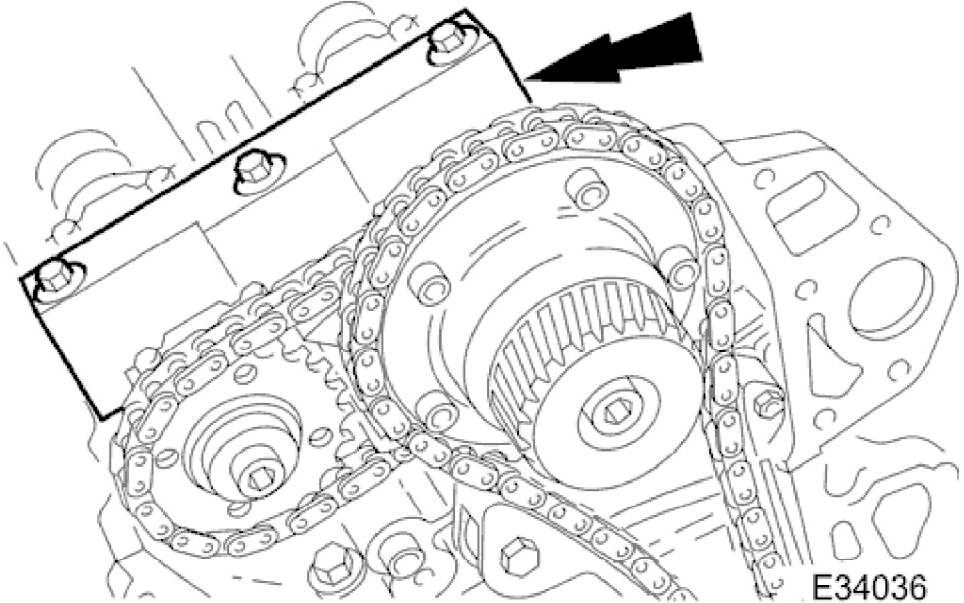

8. Install the camshaft locking tool 303-530 to the right-hand bank camshafts, aligning the shafts as necessary.

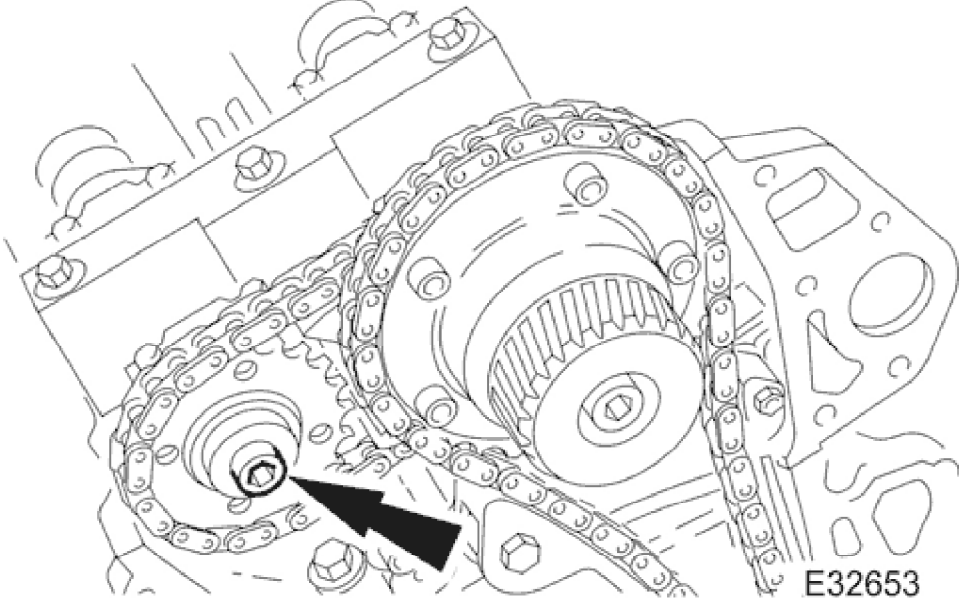

9. Loosen the exhaust camshaft sprocket bolt.

2001 S-TYPE - Engine - 4.0L - 303-01B

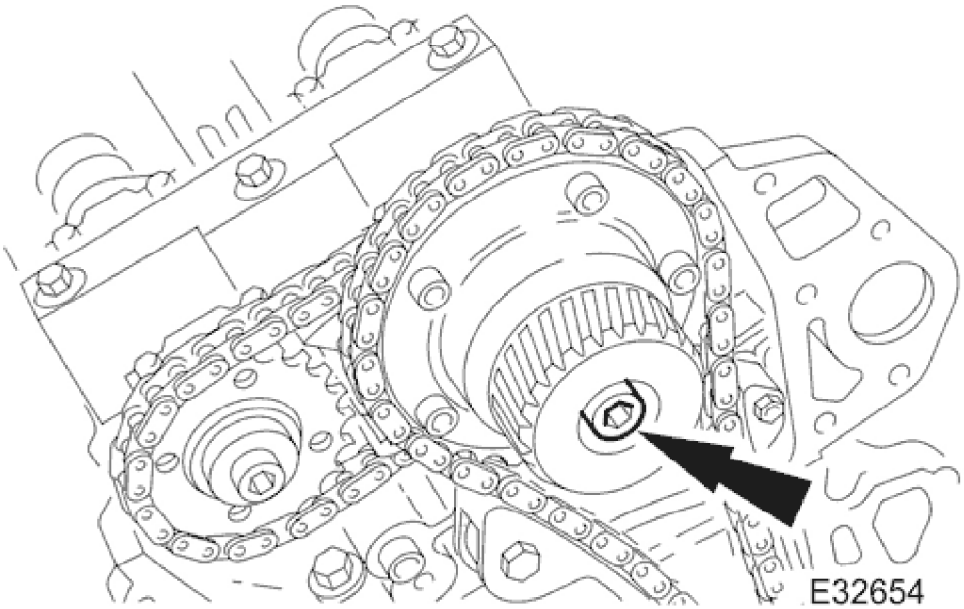

10. Loosen the intake camshaft VVT unit bolt.

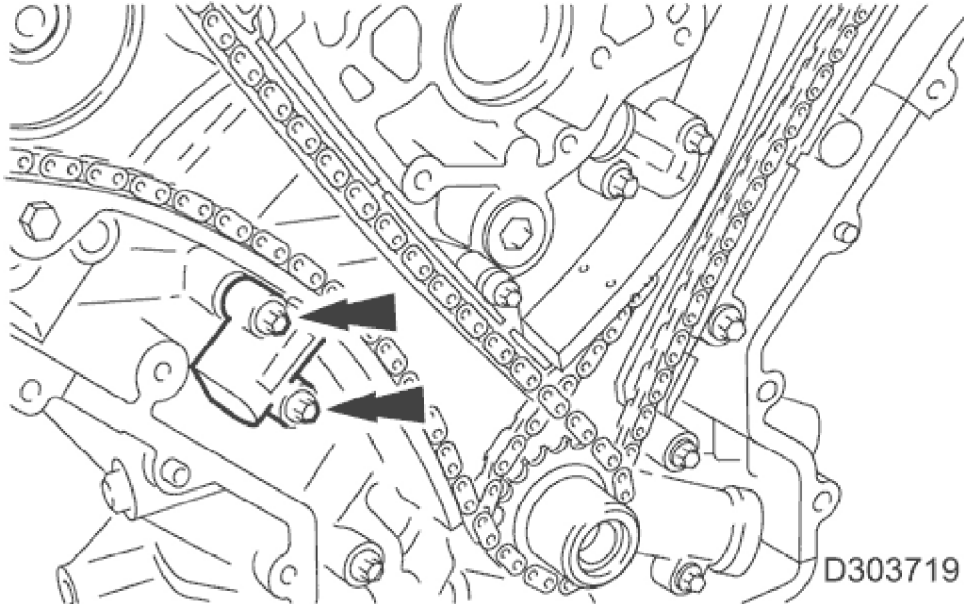

11. Detach the primary chain tensioner.

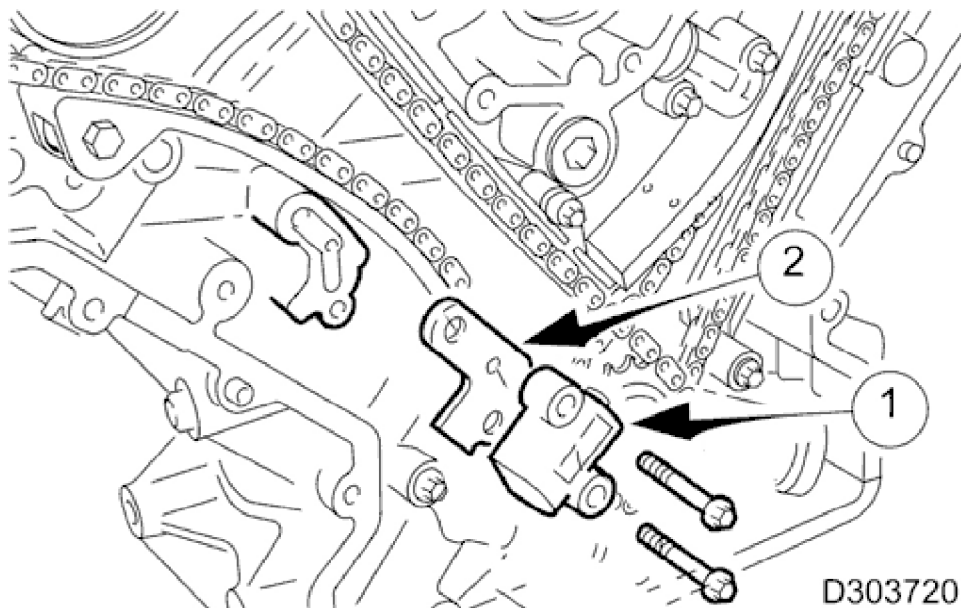

12. Remove the tensioner assembly.
1. Remove the tensioner.
2. Remove the tensioner back-plate.

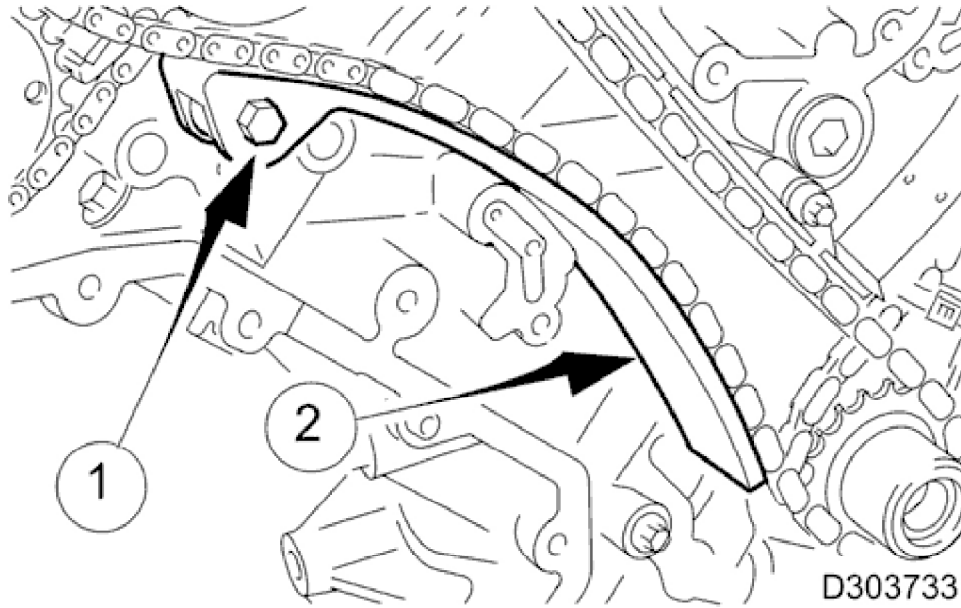

13. Remove the chain tensioner blade.
1. Remove the tensioner blade pivot bolt.
2. Remove the tensioner blade.

14. Remove the right-hand bank primary timing chain.

Installation

2001 S-TYPE - Engine - 4.0L - 303-01B

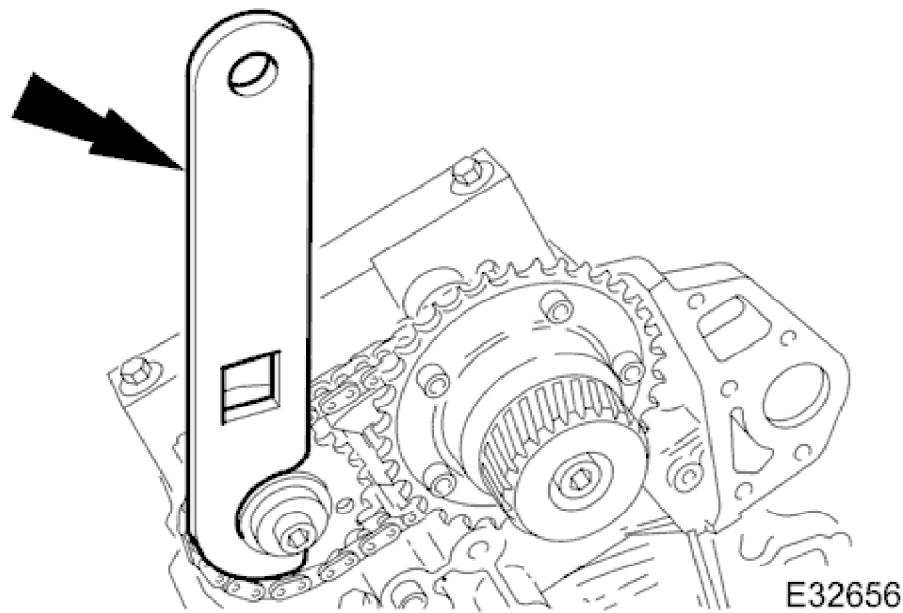

1. Install the chain tensioning tool 303-532 to the exhaust camshaft sprocket.
 - Reposition the sprocket (and the VVT unit) for the most advantageous position for use of the tool.
 - Remove the tool.

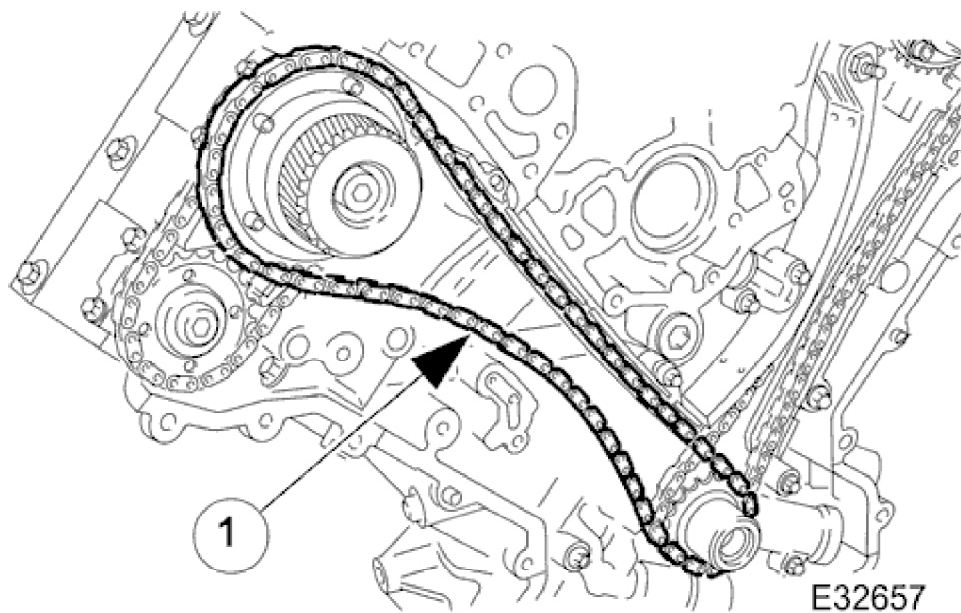

2. Install the primary timing chain.
 1. Install the primary chain over the crankshaft sprocket and the VVT unit sprocket. There must be no slack on the drive side of the primary chain and the VVT unit must not be rotated on the camshaft.

2001 S-TYPE - Engine - 4.0L - 303-01B

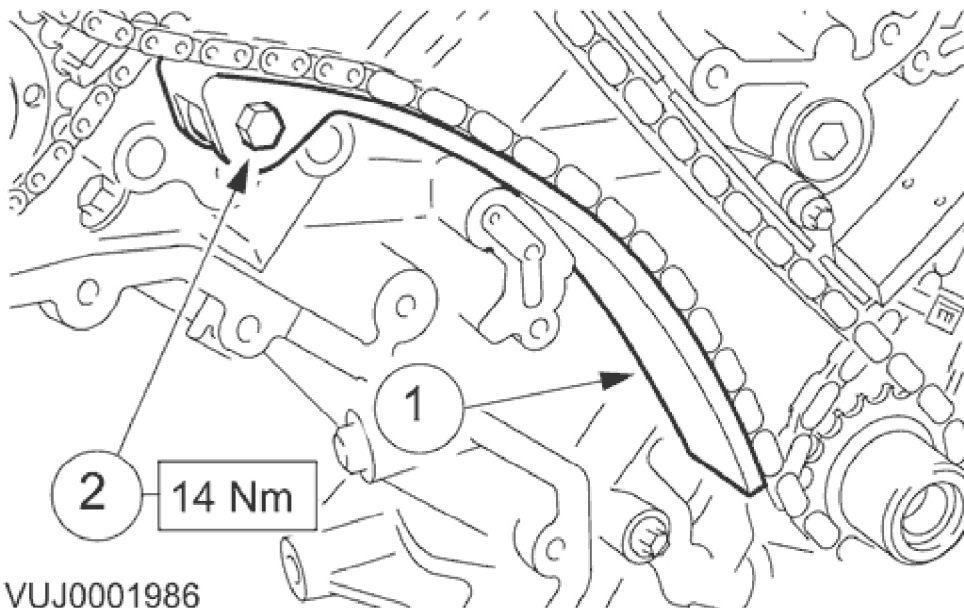

VUJ0001986

- 3. Install the primary chain tensioner blade.
 - 1. Install the primary chain tensioner blade bolt.
 - 2. Install the primary chain tensioner blade.

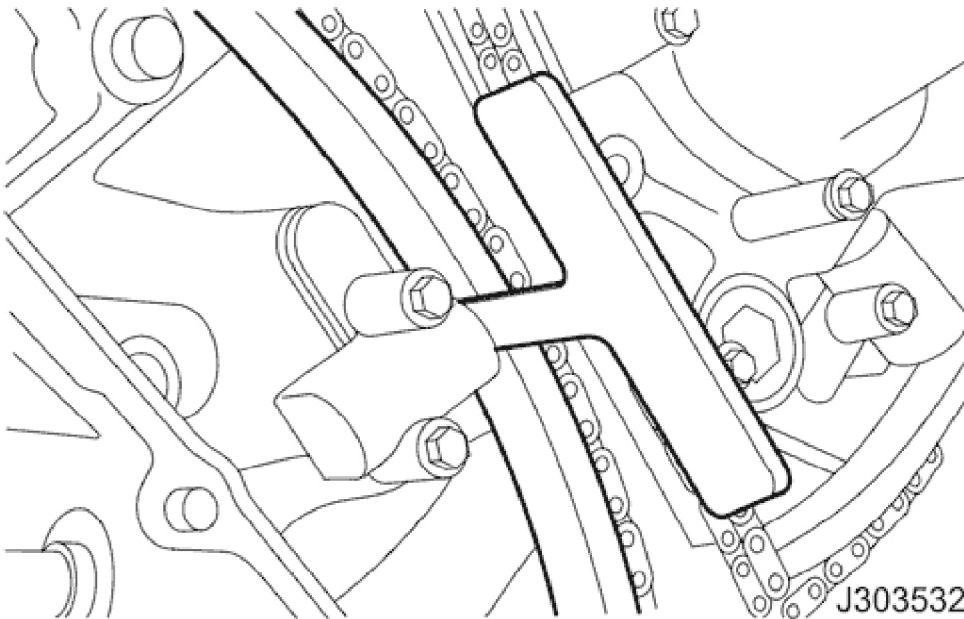

- 4. Install the primary chain tensioner assembly.
 - 1. Use a wedge 303-533 (or two if required) between the primary chain tensioner and tensioner blade, to take up the slack in the chain.

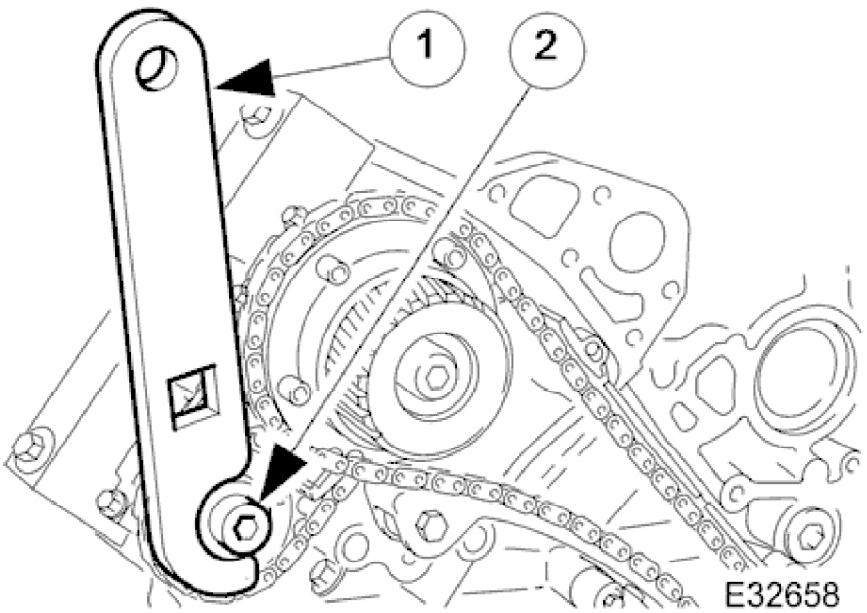

- 5. Tighten the exhaust camshaft sprocket securing bolt.
 - 1. Install the chain tensioner tool 303-532 to the sprocket holes.
 - Apply force to the tool in an anti-clockwise direction to tension the chain on its drive side.
 - 2. While applying the opposing force to sprocket and chain, tighten the sprocket bolt to 120 Nm.

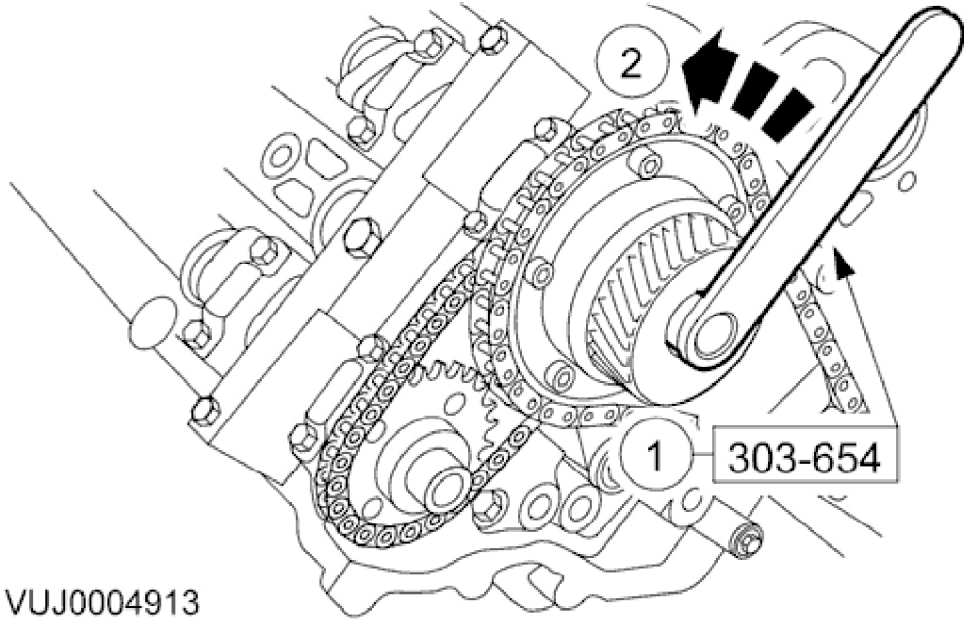

VUJ0004913

- 6. Rotate the variable camshaft timing oil control unit fully counter-clockwise to the fully retarded position.
 - 1. Install the variable camshaft timing oil control unit setting tool 303-654.
 - 2. Rotate the variable camshaft timing oil control unit fully anti-clockwise to the fully retarded position.

2001 S-TYPE - Engine - 4.0L - 303-01B

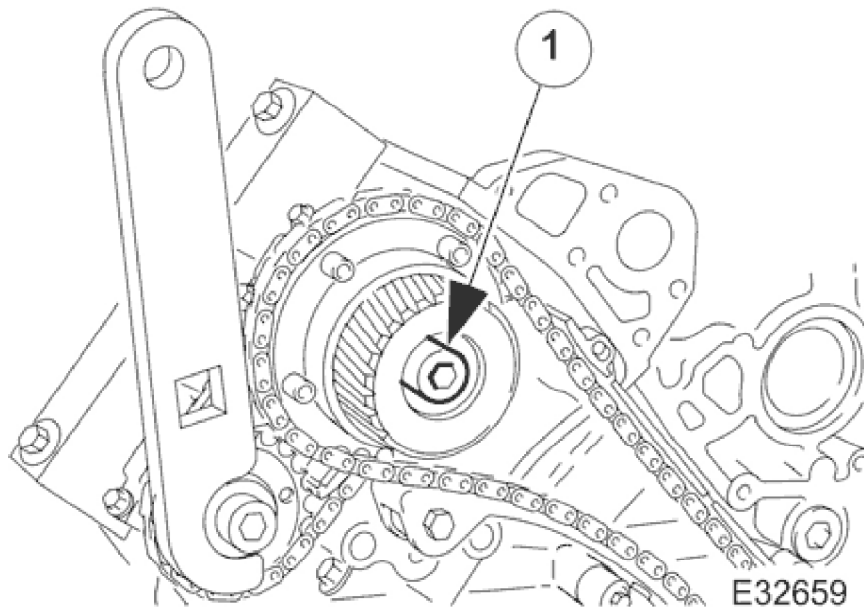

7. Tighten the VVT unit bolt.

1. While still applying the opposing force to the sprocket and chain (using 303-532), check that the wedges are still in place, carry out the variable camshaft timing oil control unit retaining bolt tightening sequence.
 - Tighten to 40 Nm + 90°.
 - Remove the chain tensioning tool and the wedge(s).

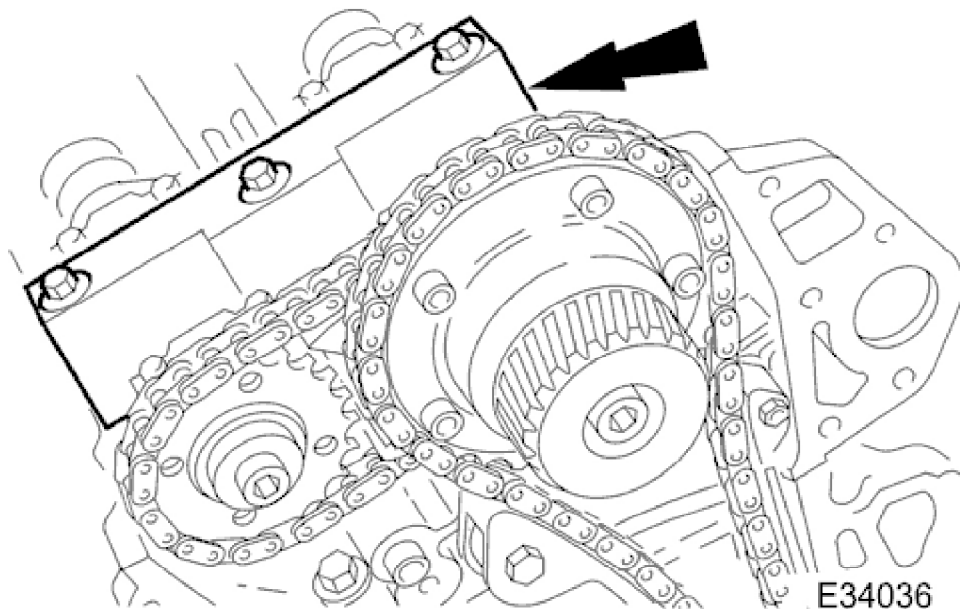

8. Remove the camshaft locking tool 303-530.

9. Raise and support the vehicle. <<100-02>>[Lifting]

10. Remove the crankshaft setting tool 303-531.

2001 S-TYPE - Engine - 4.0L - 303-01B

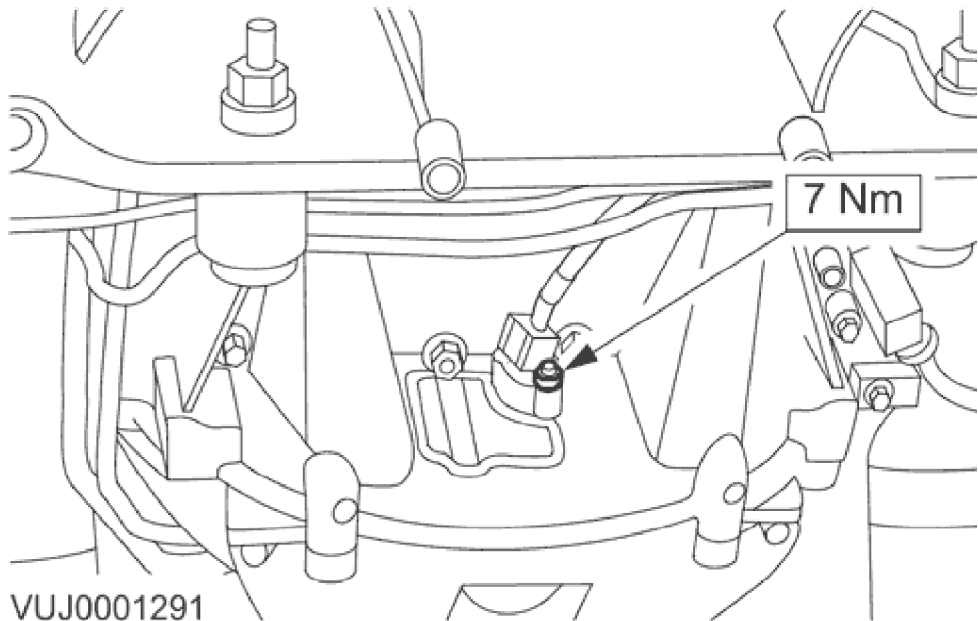

- 11. Install the crankshaft position sensor.
- 12. Reconnect the crankshaft position sensor electrical connector.

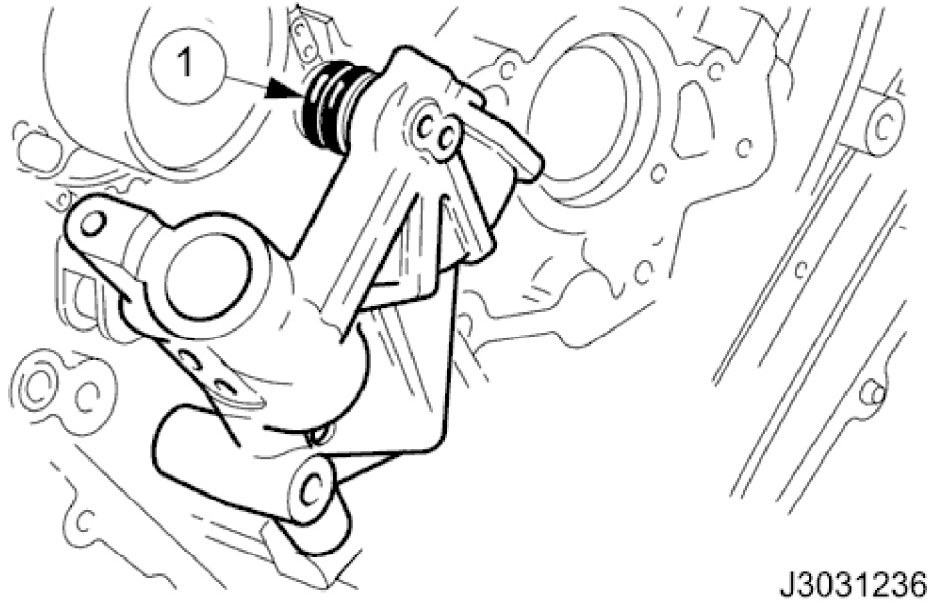

- 13. Install new seals to the VVT bush carrier.

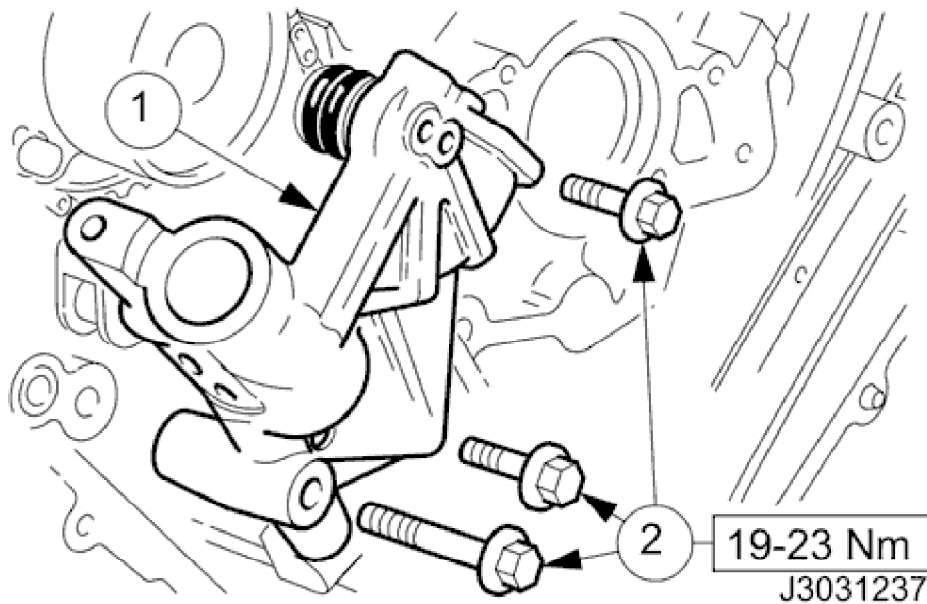

14. **NOTE:**

Make sure the bush carrier oil inlet filter screen is clean.

Install the VVT bush carrier to the cylinder block.

1. Install the bush carrier assembly.
 - Lubricate the seals and the bush.
 - Check that the ring dowels are engaged squarely. Fully locate the assembly as much as possible by hand pressure.
2. Install the VVT bush carrier bolts.

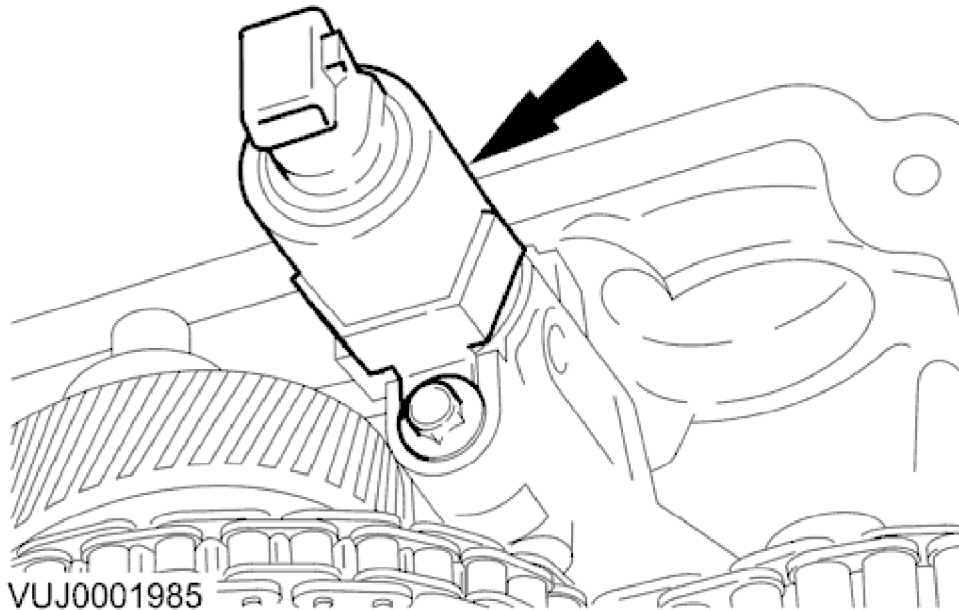

15. Install the VVT solenoid.

16. Install the engine front cover. <<Engine Front Cover>>