

SIGHT WINDOW, LOW PRESSURE

NOTE :

1. Customer must specify internal or external pressure.
2. For safe and reliable performance do not exceed recommended NPT/BSPT torque standards when tightening sight windows.

NPT/BSPT	B	C	D	E
2"	3.000	1.875	0.760	0.290
1-1/2"	2.250	1.510	0.715	0.260
1-1/4"	2.000	1.300	0.670	0.250
1"	1.562	0.980	0.670	0.250
3/4"	1.325	0.760	0.549	0.200
1/2"	1.000	0.610	0.525	0.200
3/8"	0.812	0.460	0.396	0.175
1/4"	0.687	0.350	0.396	0.175

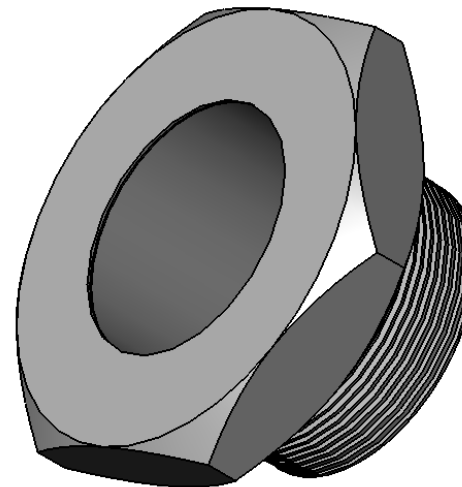
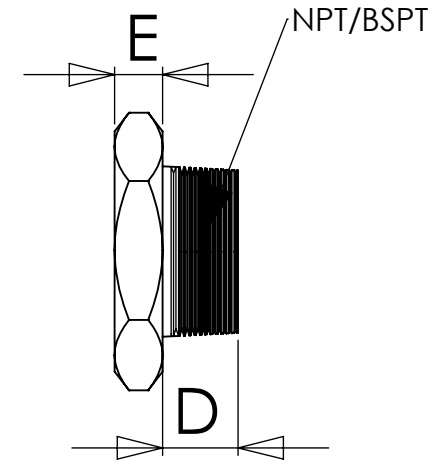
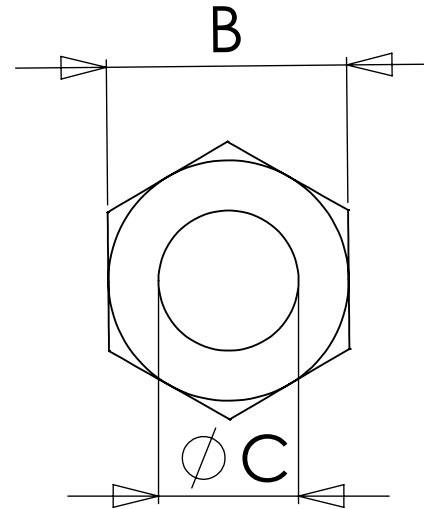

NOMINAL DIAMETER NPT/BSPT
1/4" - 0.540"
3/8" - 0.675"
1/2" - 0.840"
3/4" - 1.050"
1" - 1.315"
1-1/4" - 1.660"
1-1/2" - 1.900"
2" - 2.375"

WINDOW MATERIAL OPTIONS:

- GLASS
- FUSED SILICA
- SAPPHIRE
- CUSTOM

PROPRIETARY AND CONFIDENTIAL
 THE INFORMATION CONTAINED IN THIS DRAWING IS THE SOLE PROPERTY OF RAYOTEK SCIENTIFIC, INC. ANY REPRODUCTION IN PART OR AS A WHOLE WITHOUT THE WRITTEN PERMISSION OF RAYOTEK SCIENTIFIC, INC. IS PROHIBITED.

DIMENSIONS ARE IN INCHES TOLERANCES: ± 0.01 UNLESS NOTED	NAME	DATE
		8/24/09
	CHECKED	
	ENG APPR.	
	MFG APPR.	
	Q.A.	
	COMMENTS:	
FINISH	---	
DO NOT SCALE DRAWING		

Rayotek Scientific, Inc,
 11499 Sorrento Valley Rd,
 San Diego, CA. 92121
 Tel: 858-558-3671

SIZE A	LP SIGHT WINDOW	Rev N
SCALE:2:1	WEIGHT:	SHEET 1 OF 1