



X-TYPE

DATE 06/03
Amended 12/04

XT501-08

SERVICE

TECHNICAL BULLETIN

Passenger Footwell Water Leakage –
Leakage At Pollen Filter Housing –
Install Water Shield

MODEL 2002-03 MY
X-TYPE

VIN C00001-D16994

Remove and destroy Bulletin XT501-08, dated 06/03.
Replace with this Bulletin.
Revisions are marked with a bar and in **bold text**.

Issue:

On some 2002-03 MY X-TYPE vehicles within the above VIN range, customers may complain of water leaking into the passenger footwell.

A water shield is now available that can be installed on the curb side of the pollen filter housing to eliminate this concern.

Action:

In case of a verified customer complaint of water leaking past the pollen filter housing, install a water shield as outlined below.

WORKSHOP PROCEDURE

1. Remove pollen filter. (See Workshop Manual, section: 412-01, SRO 76.10.09).
2. Remove pollen filter housing securing nuts.
3. Displace and remove pollen filter housing.
4. If present, remove any excess 'hot melt' glue that may obstruct the installation of the water shield.
5. Clean local area of pollen filter housing where water shield will be installed.

NOTE: THE INFORMATION IN TECHNICAL BULLETINS IS INTENDED FOR USE BY TRAINED, PROFESSIONAL TECHNICIANS WITH THE KNOWLEDGE, TOOLS, AND EQUIPMENT TO DO THE JOB PROPERLY AND SAFELY. IT INFORMS THESE TECHNICIANS OF CONDITIONS THAT MAY OCCUR ON SOME VEHICLES, OR PROVIDES INFORMATION THAT COULD ASSIST IN PROPER VEHICLE SERVICE. THE PROCEDURES SHOULD NOT BE PERFORMED BY "DO-IT-YOURSELFERS." DO NOT ASSUME THAT A CONDITION DESCRIBED AFFECTS YOUR CAR. CONTACT A JAGUAR DEALER TO DETERMINE WHETHER THE BULLETIN APPLIES TO YOUR VEHICLE.

6. For pollen filter housings with a double slot, cut and remove material from water shield (Illustration 1).

Note: Ensure that the four corners of the original cutout remain for location purposes.

Note: Sufficient material should be removed to allow water shield to seal flat against housing.

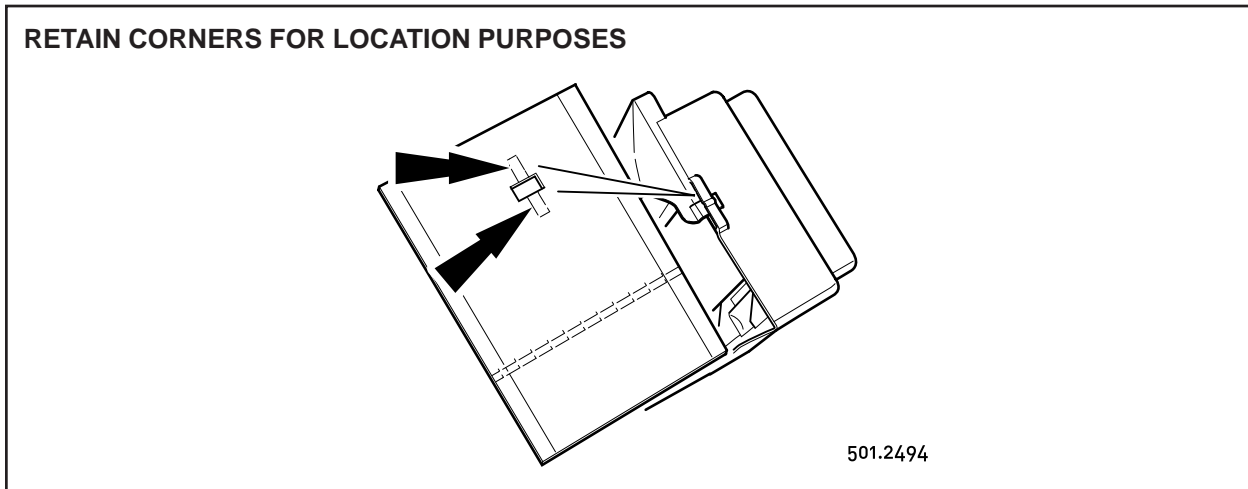

ILLUSTRATION 1

7. Remove and discard backing paper from water shield, align and affix water shield to pollen filter housing. (Illustration 2 if single slot pollen filter housing) (Illustration 3 if double slot pollen filter housing).

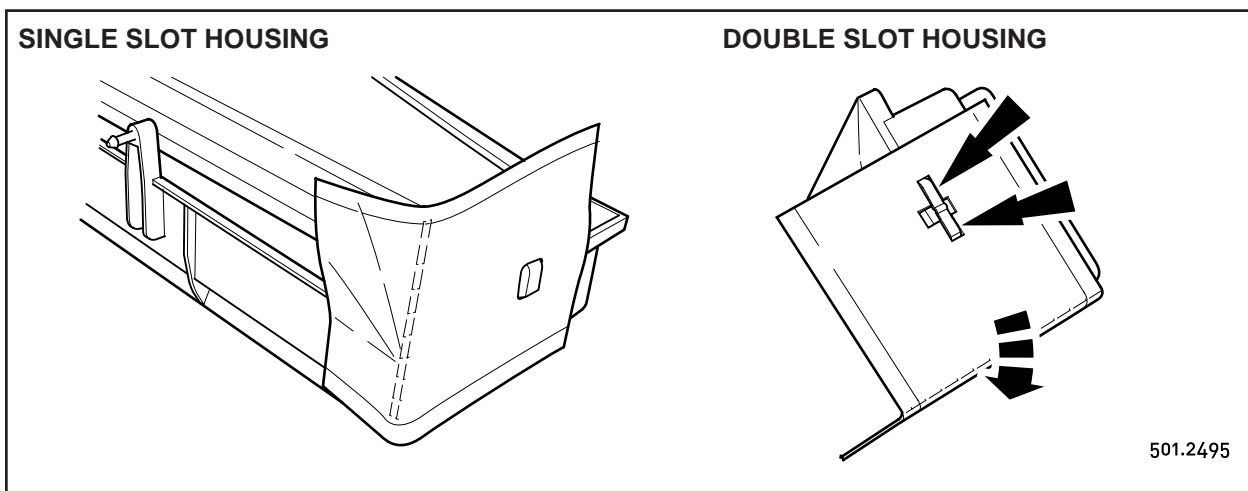

ILLUSTRATION 2

ILLUSTRATION 3

8. Install pollen filter housing.
9. Install and tighten pollen filter housing securing nuts.
10. Install pollen filter. (See Workshop Manual, section: 412-01, SRO 76.10.09).

Global Technical Reference (GTR) Workshop Manual Information:

Dealer access: <https://hub.franchise.jaguar.com>

Internet access: <http://www.jaguartechno.com>

Parts Information:

<u>DESCRIPTION</u>	<u>PART NUMBER</u>	<u>QTY</u>
Pollen filter housing water shield (left hand drive)	C2S 29537	1

Warranty Information:

Warranty claims should be submitted quoting the information found in the table below. This will result in payment of the stated time and, where applicable parts/miscellaneous expense codes as listed.

Description	SRO	Time	Causal Part Number
Install pollen filter housing water shield	76.94.21	0.5 hrs.	C2S 29537