

Battery Disconnect

Disconnect



WARNING:

BATTERIES NORMALLY PRODUCE EXPLOSIVE GASES WHICH MAY CAUSE PERSONAL INJURY, THEREFORE DO NOT ALLOW LIGHTED SUBSTANCES TO COME NEAR THE BATTERY. WHEN CHARGING OR WORKING NEAR THE BATTERY ALWAYS SHIELD YOUR FACE AND PROTECT YOUR EYES. ALWAYS PROVIDE ADEQUATE VENTILATION. FAILURE TO FOLLOW THESE INSTRUCTIONS MAY RESULT IN PERSONAL INJURY.



WARNING:

BATTERIES CONTAIN SULPHURIC ACID, AVOID CONTACT WITH SKIN, EYES OR CLOTHING. SHIELD YOUR FACE AND PROTECT YOUR EYES WHEN WORKING NEAR THE BATTERY TO GUARD AGAINST POSSIBLE SPLASHING OF THE ACID SOLUTION. IN CASE OF ACID CONTACT WITH THE SKIN OR EYES, FLUSH IMMEDIATELY FOR A MINIMUM OF 15 MINUTES AND SEEK PROMPT MEDICAL ATTENTION. IF SWALLOWED, CALL A PHYSICIAN IMMEDIATELY. FAILURE TO FOLLOW THESE INSTRUCTIONS MAY RESULT IN PERSONAL INJURY.



WARNING:

AUDIO UNIT KEY CODE SAVING DEVICES MUST NOT BE USED WHEN WORKING ON SUPPLEMENTAL RESTRAINT OR FUEL SYSTEMS. WHEN USING THESE DEVICES THE VEHICLE ELECTRICAL SYSTEM IS STILL LIVE BUT WITH A REDUCED CURRENT FLOW. FAILURE TO FOLLOW THIS INSTRUCTION MAY RESULT IN PERSONAL INJURY.



CAUTION:

Make sure the engine is not running before disconnecting the battery ground cable. Failure to follow this instruction may result in damage to the vehicles electrical system.

NOTE:

Before disconnecting the battery make sure that no data is required from the engine control module (ECM), as battery cable disconnection will erase any fault codes and idle/drive values held in the keep alive memory (KAM). It is not necessary to disconnect or remove electronic control modules.

NOTE:

This procedure should be used to disconnect the battery while carrying out repairs that refer to the battery being disconnected.

1. Obtain and record the audio unit keycode and preset radio frequencies.

2004 X-TYPE - Battery, Mounting and Cables - 414-01

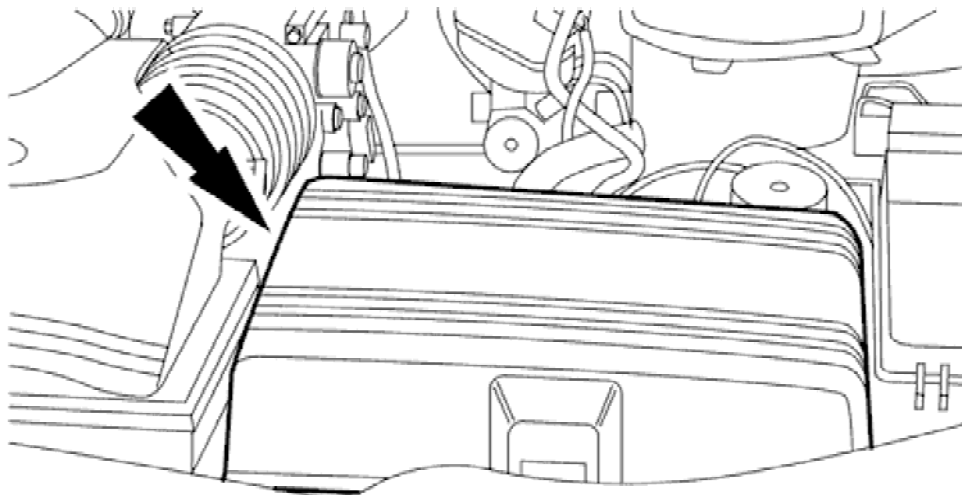

E41358

2. Remove the battery cover.

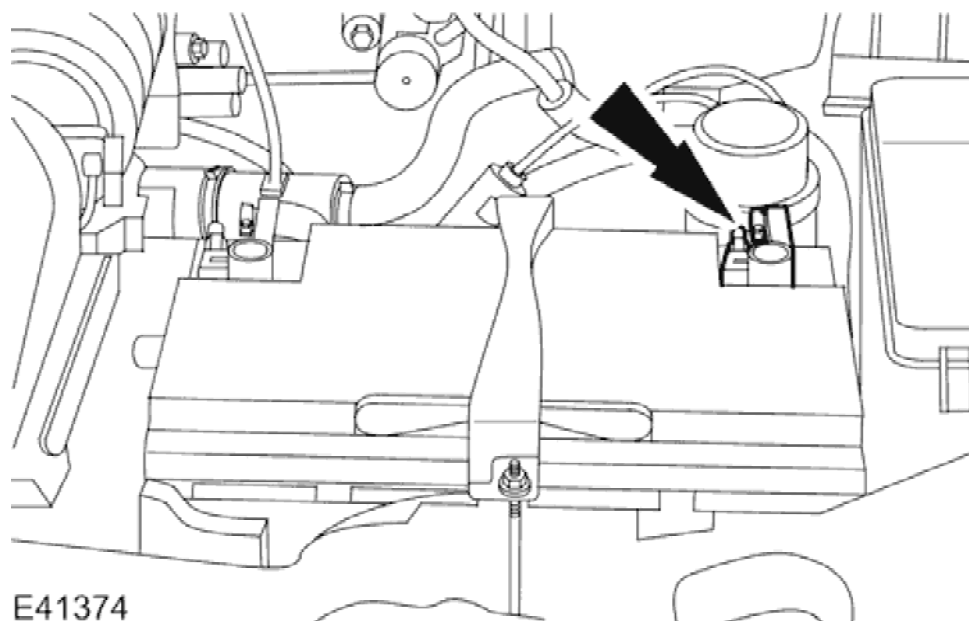

E41374

3. Disconnect the battery ground cable.