



Electrical Guide

X-TYPE

Sedan and Estate (Wagon)

2.0 L, 2.5 L and 3.0 L Gasoline;

2.0 L and 2.2 L, Diesel

VIN: E19616 on



BY APPOINTMENT TO
HER MAJESTY QUEEN ELIZABETH II
MANUFACTURERS OF DAIMLER AND JAGUAR CARS
JAGUAR CARS LIMITED COVENTRY



BY APPOINTMENT TO
HER MAJESTY QUEEN ELIZABETH
THE QUEEN MOTHER
MANUFACTURERS OF DAIMLER AND JAGUAR CARS
JAGUAR CARS LIMITED COVENTRY



BY APPOINTMENT TO
HIS ROYAL HIGHNESS THE PRINCE OF WALES
MANUFACTURERS OF DAIMLER AND JAGUAR CARS
JAGUAR CARS LIMITED COVENTRY

Electrical Guide

X-TYPE

Sedan and Estate (Wagon)

2.0 L, 2.5 L and 3.0 L Gasoline;

2.0 L and 2.2 L, Diesel

VIN: E19616 on

Published by Technical Communications, **Jaguar Cars Limited**

Publication Part Number JJM 10 38 20 701, January 2007

While every effort is made to ensure accuracy, design changes to the vehicle may be made in the period between the completion of this publication and the introduction of vehicles.

All rights reserved. No part of this publication may be reproduced, stored in a retrieval system or transmitted, in any form: electronic, mechanical, including photocopying, recording or other means without prior written permission from the Service Division of Jaguar Cars Limited.

Table of Contents: Figures	2
Abbreviations and Acronyms	5
Introduction	6
User Instructions	7
Symbols and Codes	9
Network Configuration	13
Relay and Fuse Location	14
Fusebox Connectors	16
Major Harnesses and Fusebox Location	17
Harness In-Line Connector Location	19
Ground Point Location	22
Control Module Location	23
Control Module Pin Identification	25
Electrical Guide Figures and Data	follows after page 32 (pages are numbered by Figure number)
Component Index	follows Electrical Guide Figures and Data

FIGURES

Fig.	Description	Variant
01 Power Distribution		
Fig. 01.1	Main Power Distribution	All Vehicles
Fig. 01.2	Battery Power Distribution: Part 1	All Vehicles
Fig. 01.3	Battery Power Distribution: Part 2	All Vehicles
Fig. 01.4	Ignition Switched Power Distribution: I (Accessory)	All Vehicles
Fig. 01.5	Ignition Switched Power Distribution: II (Run) – Part 1	All Vehicles
Fig. 01.6	Ignition Switched Power Distribution: II (Run) – Part 2	All Vehicles
Fig. 01.7	Ignition Switched Power Distribution: Battery Saver	All Vehicles
Fig. 01.8	EMS Switched Power Distribution: Gasoline Engines	Gasoline Engine Vehicles
Fig. 01.9	EMS Switched Power Distribution: Diesel Engines	Diesel Engine Vehicles
02 Battery; Starter; Generator		
Fig. 02.1	Battery; Starter; Generator: 2.5 L & 3.0 L	2.5 L & 3.0 L Vehicles
Fig. 02.2	Battery; Starter; Generator: 2.0 L	2.0 L Gasoline Engine Vehicles
Fig. 02.3	Battery; Starter; Generator: Diesel	Diesel Engine Vehicles
03 Engine Management		
Fig. 03.1	Engine Management: 2.5 L & 3.0 L – Part 1	2.5 L & 3.0 L Vehicles
Fig. 03.2	Engine Management: 2.5 L & 3.0 L – Part 2	2.5 L & 3.0 L Vehicles
Fig. 03.3	Engine Management: 2.0 L – Part 1	2.0 L Gasoline Engine Vehicles
Fig. 03.4	Engine Management: 2.0 L – Part 2	2.0 L Gasoline Engine Vehicles
Fig. 03.5	Engine Management: Diesel – Part 1	Diesel Engine Vehicles
Fig. 03.6	Engine Management: Diesel – Part 2	Diesel Engine Vehicles
04 Transmission		
Fig. 04.1	Automatic Transmission: 16-Bit TCM	16-Bit TCM Vehicles
Fig. 04.2	Automatic Transmission: 32-Bit TCM	32-Bit TCM Vehicles
05 Braking		
Fig. 05.1	Anti-Lock Braking	ABS Vehicles
Fig. 05.2	Anti-Lock Braking / Traction Control	ABS / TC Vehicles
Fig. 05.3	Dynamic Stability Control	DSC Vehicles
06 Climate Control		
Fig. 06.1	Manual Climate Control	Manual Climate Control Vehicles
Fig. 06.2	Automatic Climate Control	Automatic Climate Control Vehicles
Fig. 06.3	Glass Heaters	All Vehicles
07 Instrumentation		
Fig. 07.1	Instrument Cluster	All Vehicles
Fig. 07.2	Audible Warnings	All Vehicles

FIGURES

Fig.	Description	Variant
08 Exterior Lighting		
Fig. 08.1	Exterior Lighting: Front – Auto Headlamps	Auto Headlamp Vehicles
Fig. 08.2	Exterior Lighting: Front – Non Autolamps; Daytime Running Lamps	Non Autolamp Vehicles; Daytime Running Lamp Vehicles
Fig. 08.3	Exterior Lighting: Rear – Sedan	Sedan Vehicles
Fig. 08.4	Exterior Lighting: Rear – Estate (Wagon)	Estate (Wagon) Vehicles
Fig. 08.5	Exterior Lighting: Rear – Sedan European Trailer Towing	Euro. Sedan Trailer Towing Vehicles
Fig. 08.6	Exterior Lighting: Rear – Sedan U.K. Trailer Towing.	U.K. Sedan Trailer Towing Vehicles
Fig. 08.7	Exterior Lighting: Rear – Sedan NAS Trailer Towing	NAS Sedan Trailer Towing Vehicles
Fig. 08.8	Exterior Lighting: Rear – Estate (Wagon) European Trailer Towing	Euro. Estate (Wagon) Trailer Towing Vehicles
Fig. 08.9	Exterior Lighting: Rear – Estate (Wagon) U.K. Trailer Towing	U.K. Estate (Wagon) Trailer Towing Vehicles
Fig. 08.10	Headlamp Leveling (H/L).	H/L & HID Headlamp Vehicles
09 Interior Lighting		
Fig. 09.1	Interior Lighting	All Vehicles
Fig. 09.2	Dimmer-Controlled Lighting.	All Vehicles
10 Door Mirrors		
Fig. 10.1	Door Mirrors: Movement; Fold-back – Non Memory	Non Memory Vehicles
Fig. 10.2	Door Mirrors: Movement; Fold-back – Memory	Memory Vehicles
11 Seat Systems		
Fig. 11.1	Powered Seat: Driver – Memory	Memory Vehicles
Fig. 11.2	Powered Seat: Passenger – Memory	Memory Vehicles
Fig. 11.3	Powered Seats: 8-way Movement.	8-way Powered Seat Vehicles
Fig. 11.4	Powered Seats: 4-way Movement.	4-way Powered Seat Vehicles
Fig. 11.5	Powered Seats: 2-way Movement.	2-way Powered Seat Vehicles
Fig. 11.6	Seat Heaters: Memory.	Memory Vehicles
Fig. 11.7	Seat Heaters: Non Memory.	Heated Seat Vehicles
12 Door Locking; Security		
Fig. 12.1	Central Door Locking: Sedan – Double Locking	Double Locking Sedan Vehicles
Fig. 12.2	Central Door Locking: Sedan – Non Double Locking	Non Double Locking Sedan Vehicles
Fig. 12.3	Central Door Locking: Estate (Wagon)	Estate (Wagon) Vehicles
Fig. 12.4	Security: Sedan	Sedan Vehicles
Fig. 12.5	Security: Estate (Wagon).	Estate (Wagon) Vehicles
13 Wash / Wipe		
Fig. 13.1	Wash / Wipe: Front	Non Rain Sensing Vehicles
Fig. 13.2	Wash / Wipe: Front with Rain Sensing	Rain Sensing Vehicles
Fig. 13.3	Wash / Wipe: Rear	Estate (Wagon) Vehicles
14 Powered Windows; Sliding Roof		
Fig. 14.1	Powered Windows.	All Vehicles
Fig. 14.2	Sliding Roof.	Sliding Roof Vehicles
15 In-Car Entertainment		
Fig. 15.1	In-Car Entertainment: Standard.	Standard ICE Vehicles
Fig. 15.2	In-Car Entertainment: Premium.	Premium ICE Vehicles

FIGURES

Fig.	Description	Variant
16 Telematics		
Fig. 16.1	Telephone	ROW Vehicles
Fig. 16.2	Telephone with Voice Control	ROW Voice Vehicles
Fig. 16.3	Voice Control System	NAS Voice Vehicles
Fig. 16.4	Navigation System.	NAV Vehicles (except Japan)
Fig. 16.5	Navigation System: Japan.	Japan Vehicles
17 Occupant Protection		
Fig. 17.1	Advanced Restraint System: Front Wheel Drive	Front Wheel Drive Vehicles
Fig. 17.2	Advanced Restraint System: All Wheel Drive	All Wheel Drive Vehicles
18 Driver Assist		
Fig. 18.1	Parking Aid	Parking Aid Vehicles
19 Ancillaries		
Fig. 19.1	Ancillaries	All Vehicles
20 Vehicle Multiplex Systems		
Fig. 20.1	Controller Area Network: LHD	LHD Vehicles
Fig. 20.2	Controller Area Network: RHD.	RHD Vehicles
Fig. 20.3	Standard Corporate Protocol Network; Serial Data Link	All Vehicles
Fig. 20.4	D2B Network	All Vehicles

The following abbreviations and acronyms are used throughout this Electrical Guide:

2.0 L	2.0 L V6 Vehicles
2.5 L, 3.0 L	2.5 L and 3.0 L V6 Vehicles
A/C	Air Conditioning
APP SENSOR	Accelerator Pedal Position Sensor
APP1	Accelerator Pedal Position Sensor Element 1
APP2	Accelerator Pedal Position Sensor Element 2
APP3	Accelerator Pedal Position Sensor Element 3
AWD	All Wheel Drive
B+	Battery Voltage
BANK 1	RH Cylinder Bank (Cylinders 1, 3, 5)
BANK 2	LH Cylinder Bank (Cylinders 2, 4, 6)
CAN	Controller Area Network
CHT SENSOR	Cylinder Head Temperature Sensor
CKP SENSOR	Crankshaft Position Sensor
CMP SENSOR / 1	Camshaft Position Sensor / RH Bank
CMP SENSOR / 2	Camshaft Position Sensor / LH Bank
D2B	D2B Network
DIESEL	2.0 L and 2.2 L Diesel Vehicles
ECT SENSOR	Engine Coolant Temperature Sensor
EFT SENSOR	Engine Fuel Temperature Sensor
EGR VALVE	Exhaust Gas Recirculation Valve
EGT SENSOR	Exhaust Gas Temperature Sensor
EMS	Engine Management System
EOT SENSOR	Engine Oil Temperature Sensor
EST / WAG	Estate / Wagon Vehicles
EVAP CANISTER CLOSE VALVE	Evaporative Emission Canister Close Valve
EVAP CANISTER PURGE VALVE	Evaporative Emission Canister Purge Valve
FTP SENSOR	Fuel Tank Pressure Sensor
FWD	Front Wheel Drive
GPS	Global Positioning System
HID	High Intensity Discharge
HO2 SENSOR 1 / 1	Heated Oxygen Sensor – RH Bank / Upstream
HO2 SENSOR 1 / 2	Heated Oxygen Sensor – RH Bank / Downstream
HO2 SENSOR 2 / 1	Heated Oxygen Sensor – LH Bank / Upstream
HO2 SENSOR 2 / 2	Heated Oxygen Sensor – LH Bank / Downstream
IAT SENSOR	Intake Air Temperature Sensor
ICE	In-Car Entertainment System
IMT SOLENOID VALVE / 1	Intake Manifold Tuning Valve / Bottom
IMT SOLENOID VALVE / 2	Intake Manifold Tuning Valve / Top
IP SENSOR	Injection Pressure Sensor
KS	Knock Sensor
LH	Left-Hand
LHD	Left-Hand Drive
MAF SENSOR	Mass Air Flow Sensor
MAP SENSOR	Manifold Absolute Pressure Sensor
N/A	Normally Aspirated
NAS	North American Specification
PATS	Passive Anti-Theft System
PWM	Pulse Width Modulated
RH	Right-Hand
RHD	Right-Hand Drive
ROW	Rest of World
SCP	Standard Corporate Protocol Network
SEDAN	Sedan Vehicles
T-MAP SENSOR	Temperature Manifold Absolute Pressure Sensor
TP SENSOR	Throttle Position Sensor
TP1	Throttle Position Sensor Element 1
TP2	Throttle Position Sensor Element 2
TURN	Turn Signal
TV	Television
V6	V6 Engine
VVT SOLENOID VALVE / 1	Variable Valve Timing Valve / Bank 1
VVT SOLENOID VALVE / 2	Variable Valve Timing Valve / Bank 2
+ve	Positive
-ve	Negative

Electrical Guide Format

This Electrical Guide is made up of two major sections:

- the first section, at the front of the book, provides general information for and about the use of the book; model-specific information and illustrations to aid in the understanding of the Jaguar X-TYPE electrical / electronic systems, as well as the location and identification of components.
- the second section includes the Figures, which are the basis of the book. Each Figure is identified by a Figure Number (e.g. Fig. 01.1) and Title. The page adjacent to the Figure contains data information specific to that Figure.

NOTE: Data pages are not available for inclusion in Provisional versions of the Electrical Guide.

It is recommended that the user read through the front section of the book to develop a familiarity with the layout of the book and with the system of symbols and abbreviations used. The **Table of Contents** should help to guide the user.

Vehicle Identification Numbers (VIN)

VIN ranges are presented throughout the book in the following manner:

› VIN 123456 indicates 'up to VIN 123456'; VIN 123456 › indicates 'from VIN 123456 on'.

Electrical System Architecture

Power Supplies

The electrical system is a supply-side switched system. The ignition switch directly carries much of the ignition switched power supply load.

Power supply is provided via three methods:

- Direct battery power supply;
- Ignition switched power supply;
- 'Battery Saver Power Supply'.

The 'Battery Saver Power Supply' circuit is controlled via the GEM (General Electronic Module). Refer to Fig. 01.7 for circuit activation details.

Fuseboxes

The electrical harness incorporates two serviceable power distribution fuseboxes:

- the Power Distribution Fusebox located in the engine compartment;
- the Passenger Junction Fusebox located in the left-hand 'A' Post

All fuses and relays (except the trailer towing accessory kit and two Diesel vehicle relays) are located in the two fuseboxes.

Vehicle Networks

The X-TYPE employs three different networks:

- CAN (Controller Area Network) for high-speed power train communications;
- SCP (Standard Corporate Protocol) network for slower speed body systems communications;
- D2B (Optical) Network for very high-speed 'real-time' audio data transfer.

NOTE: The D2B Network is a fiber optic network with a gateway to the remaining vehicle networks via the Audio Unit. Technician access to the three networks and the Serial Data Link is via the Data Link Connector.

Ground Studs

Circuit ground connections are made at body studs located throughout the vehicle. There are no separate power and logic grounding systems; however, there are a certain number of components that use unique ground points.

Figure and Data Page Layout

Figure Pages

Each Figure represents a specific electrical system of the vehicle. The Figures are arranged numerically by system (**01 – Power Distribution, 02 – Battery; Starter; Generator**, etc.) with variations in the system identified by a numeral following a decimal point (**01.1, 01.2**, etc.). Refer to the **Table of Contents: Figures** for a complete list of the Figures.

The Figures **01 – Power Distribution** detail the distribution of power to each of the systems. Numbered reference symbols refer the user to a specific Figure and from a specific Figure back to the Power Distribution Figures. This method eliminates the need to include detailed Power Distribution information on each of the Figures. The reference symbols are defined on page 9.

Each Figure appears on a right-hand page with a corresponding Data page to the left. The Figure and Data pages are folding pages. The user must fold out both pages in order to access all the information provided.









Data Pages

The Data page includes information to assist the user in identifying and locating components, connectors and grounds. This information is supplemented by the illustrations in this front section of the book.











Most circuits that incorporate a control module include pin-out information. The characteristics listed are approximately those that can be expected at the control module connector pins with all circuit connections made and all components connected and fitted. This information is provided to assist the user in understanding circuit operation and should be used **FOR REFERENCE ONLY**.

NOTE: In the examples on this page, an 'X' is used where a number would appear on an actual Figure.

Reference Symbols

-  Battery power supply
-  Ignition switched auxiliary power supply (key I)
-  Ignition switched power supply (key II, III)
-  Ignition switched Battery Saver power supply
-  Engine Management System power supply
-  Figure number reference
-  Controller Area Network
-  Standard Corporate Protocol network
-  D2B network











Control Module Pin Symbols

-  Input
-  Output
-  Battery voltage
-  Power ground
-  Sensor / signal supply V *
-  Sensor / signal ground **
-  CAN network
-  SCP network
-  D2B network
-  Serial and encoded data

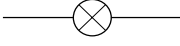
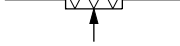
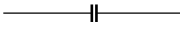
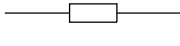
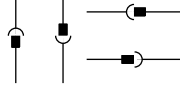
* May also indicate Reference Voltage.

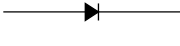
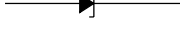
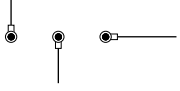
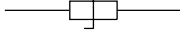
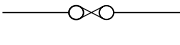
** May also indicate Reference Ground or Logic Ground.
Refer to Control Module Pin-out Information.

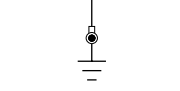
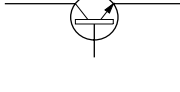
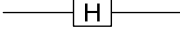
Wiring Symbols

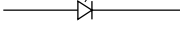
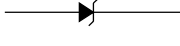
- | | | | |
|----------------------------|---|--|----------------------|
| Splice |  |  | Motor |
| Simplified splice |  |  | Potentiometer |
| Bulb |  |  | Pressure transducer |
| Capacitor |  |  | Resistor |
| Connector |  |  | Solenoid |
| Diode |  |  | Suppression diode |
| Eyelet and stud |  |  | Suppression resistor |
| Fuse |  |  | Thermistor |
| Ground |  |  | Transistor |
| Hall effect sensor |  |  | Wire continued |
| Light emitting diode (LED) |  |  | Zener diode |

Harness Codes

AC	Climate Control
AS	Side Airbag
BH	Engine Block Heaters
BL	LH Rear Door
BR	RH Rear Door
CA	Cabin
DE	Diesel Engine
DL	Diesel Engine Link
EN	Engine
FB	Front Bumper
FL	LH Front Door
FR	RH Front Door
FT	Fuel Tank
GC	Cooling Pack
IJ	Injector Rail
IP	Instrument Panel
JB	Junction Box
LF	LH Front Wheel Speed Sensor
LR	LH Rear Wheel Speed Sensor
LS	LH Front Seat
NA	Navigation System
PA	Pedal Assembly
PH	Telephone
RB	Rear Bumper
RC	Roof Console
RF	RH Front Wheel Speed Sensor
RR	RH Rear Wheel Speed Sensor
RS	RH Front Seat
SL	Security Sounder Link
TL	Trunk Lid
TT	Trailer Towing
TV	Television
WG	Tailgate Glass (Estate / Wagon only)
WL	Tailgate Link (Estate / Wagon only)
WS	Weight Sensor
WT	Tailgate (Estate / Wagon only)

Wiring Color Codes

N	Brown	O	Orange
B	Black	S	Slate
W	White	L	Light
K	Pink	U	Blue
G	Green	P	Purple
R	Red	BRD	Braid
Y	Yellow	BOF	Fiber optic (D2B Network)

Code Numbering

When numbering connectors, grounds and splices, Jaguar Engineering uses a three-position format: AC001, AC002, etc. Because space is limited in this Electrical Guide the codes have, in most cases, been shortened. Thus AC001-001 becomes AC1-1, AC002-001 becomes AC2-1, etc.

Grounds

- There may be up to three eyelets on one ground stud.
- A, B and C are used to indicate the position of the eyelet on the stud: A – first (bottom), B – second (middle), C – third (top).
- Two eyelet variations are used: a single eyelet and an eyelet pair. The single eyelet has a single ‘leg’, which is identified by an S; the eyelet pair has two ‘legs’, identified as L (left) or R (right).

EXAMPLE:



On figures where LHD and RHD circuits are combined and the ground designation differs from LHD to RHD, the RHD ground is shown in parentheses. If the ground designation is the same for LHD and RHD, only one ground designation is used.

EXAMPLE:



Relays

Serviceable Relays:

- are located in both fuseboxes;
- do not have a separate relay connector (base);
- use the ISO pin numbering system – 1, 2, 3, 4, 5;
- are identified by an ‘R’ number unique only to the fusebox in which it is located.

EXAMPLE:



Non-Serviceable Relays:

- are located in both fuseboxes;
- are a component part of the fusebox printed circuit board (PCB) and are arranged in singles or pairs;
- use the ISO pin numbering system – 1, 2, 3, 4, 5 (single relay or top pair relay) and 6, 7, 8, 9, 10 (bottom pair relay);
- are identified by an ‘R’ number unique only to the fusebox in which it is located;
- pair relays are normally depicted separately.

EXAMPLE:

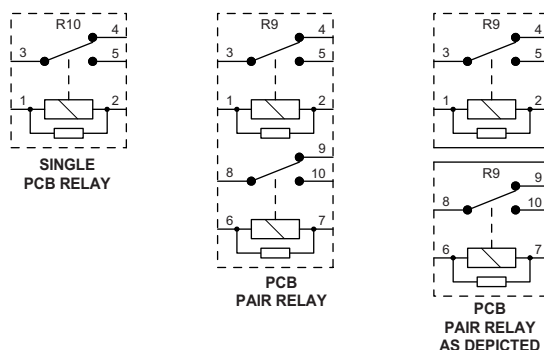

NOTE: Diesel vehicles have one serviceable relay located on the Junction Box harness and one serviceable relay attached to the Power Distribution Fusebox.

Fuses

All fuses are located in the fuseboxes. Each fuse is identified by an 'F' number unique only to the fusebox in which it is located.

EXAMPLE:

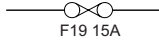

Networks

In most instances, networks are shown as a broken grey line to indicate that there is network communication between the depicted control modules. Refer to Figures 20.1, 20.2, 20.3 and 20.4 for circuit details.

EXAMPLE:

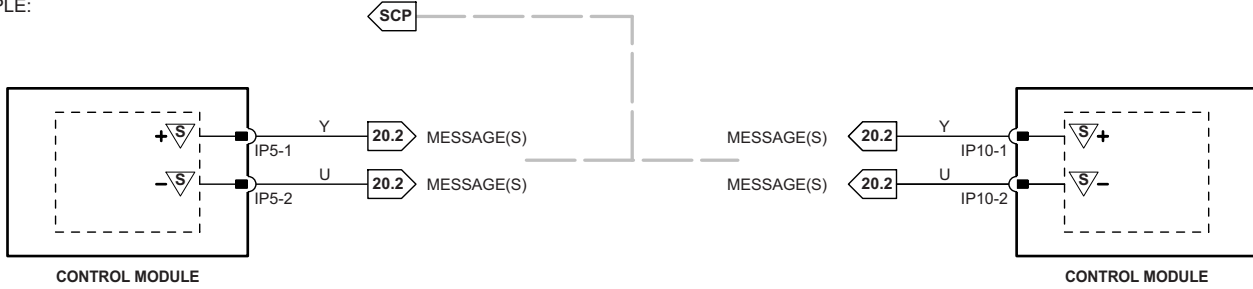

Component Depictions

EXAMPLE:



COMPLETE COMPONENTS AND CONTROL MODULES



INCOMPLETE COMPONENTS (EXCEPT CONTROL MODULES)



ASSEMBLIES AND POWER DISTRIBUTION FUSE BOXES

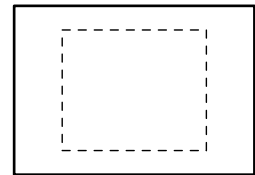

COMPONENTS WITH INTERNAL ELECTRONIC CIRCUIT

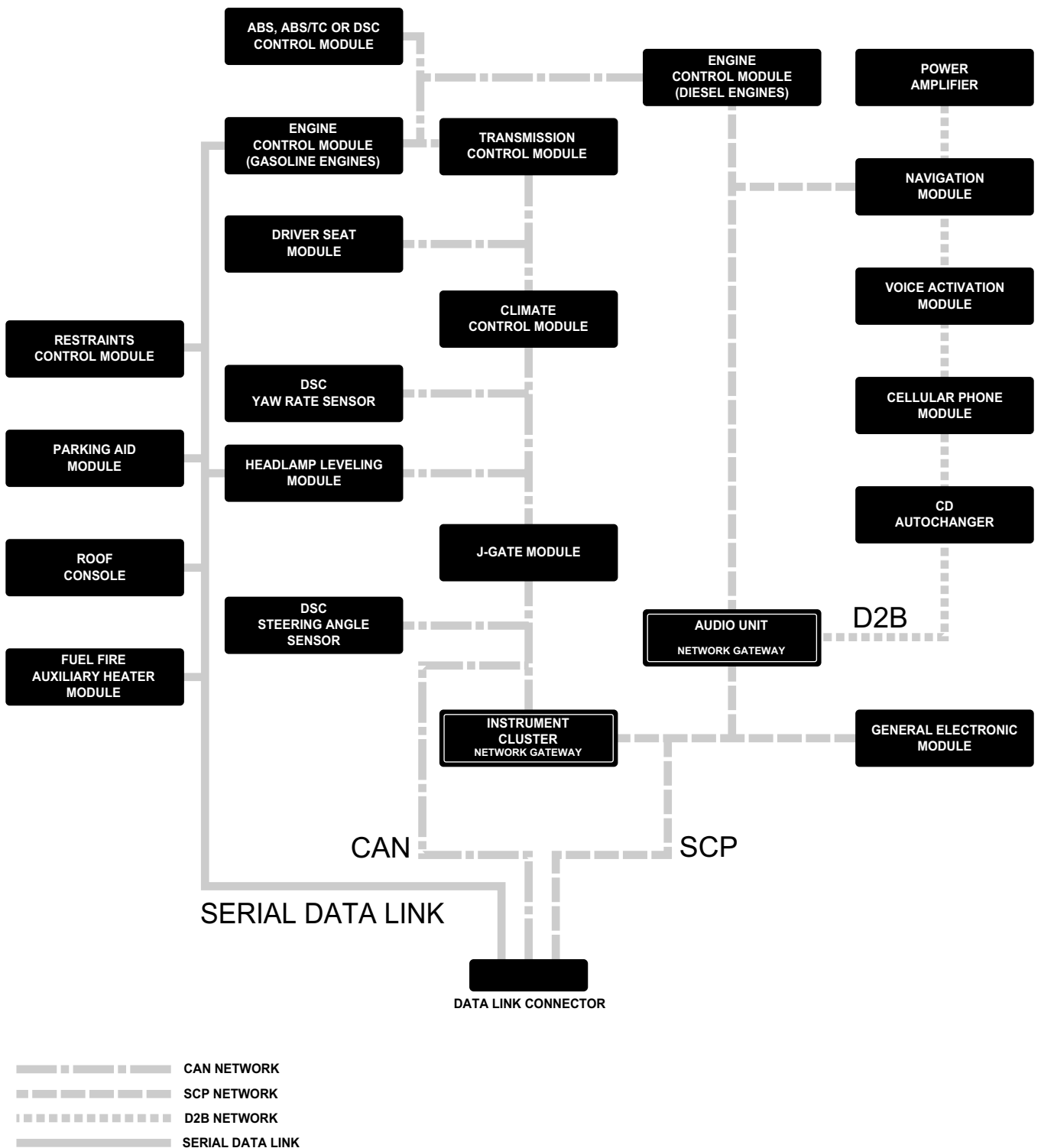

NOTE: TYPICAL NETWORK CONFIGURATION.
REFER TO FIGURES 20.1, 20.2, 20.3 AND 20.4 FOR CIRCUIT DETAILS.

POWER DISTRIBUTION FUSE BOX (TOP): GASOLINE ENGINE VEHICLES

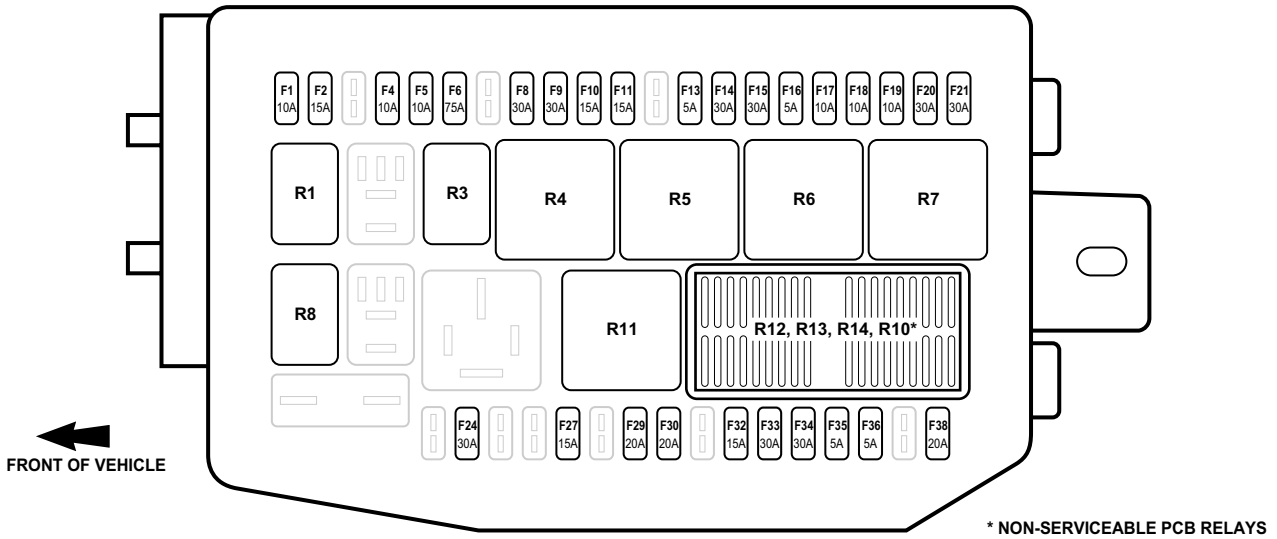

- | | |
|---|--------------------------|
| R1 MAIN BEAM / FRONT FOG RELAY | R9 NOT USED |
| R2 NOT USED | R10 NOT USED |
| R3 A/C COMPRESSOR CLUTCH RELAY | R11 DIP BEAM RELAY |
| R4 WINDSHIELD WIPER MOTOR RELAY | R12 STARTER RELAY |
| R5 POWER DISTRIBUTION FUSE BOX IGNITION RELAY | R13 SLAVE IGNITION RELAY |
| R6 WINDSHIELD HEATER RELAY | R14 NOT USED |
| R7 EMS CONTROL RELAY | R15 HORN RELAY |
| R8 POWERWASH PUMP RELAY | |

POWER DISTRIBUTION FUSE BOX (TOP): DIESEL ENGINE VEHICLES

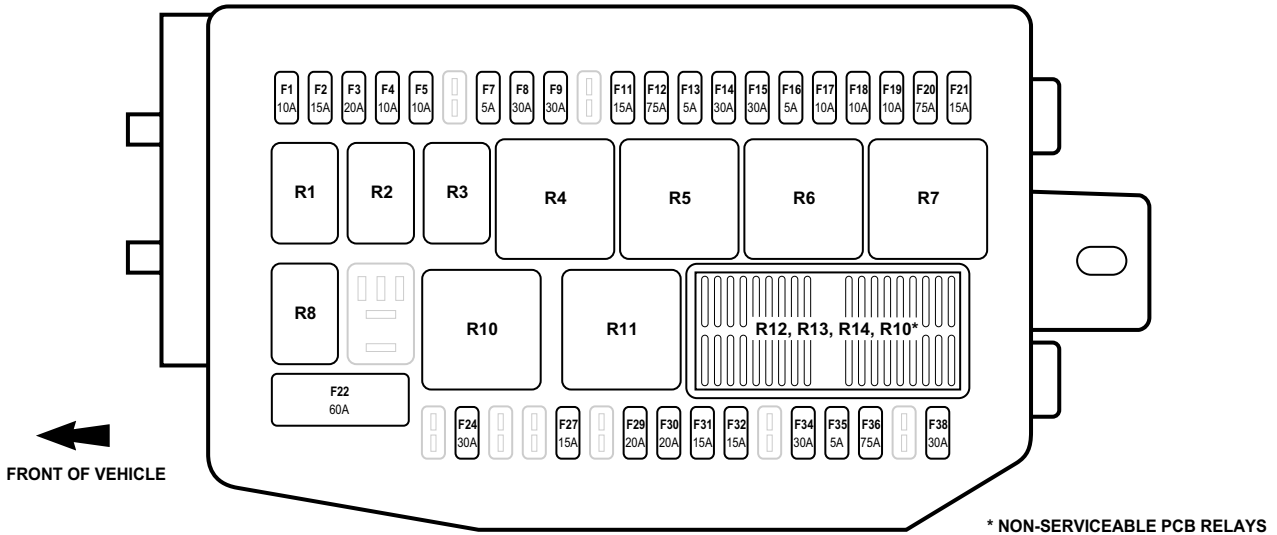

- | | |
|---|------------------------------|
| R1 MAIN BEAM / FRONT FOG RELAY | R9 NOT USED |
| R2 HORN RELAY | R10 GLOW PLUG RELAY |
| R3 A/C COMPRESSOR CLUTCH RELAY | R11 DIP BEAM RELAY |
| R4 WINDSHIELD WIPER MOTOR RELAY | R12 STARTER RELAY |
| R5 POWER DISTRIBUTION FUSE BOX IGNITION RELAY | R13 SLAVE IGNITION RELAY |
| R6 WINDSHIELD HEATER RELAY | R14 NOT USED |
| R7 EMS CONTROL RELAY | R15 AUXILIARY HEATER RELAY 1 |
| R8 POWERWASH PUMP RELAY | |

pw_dis_fuse_box_4000625

POWER DISTRIBUTION FUSE BOX (BOTTOM)

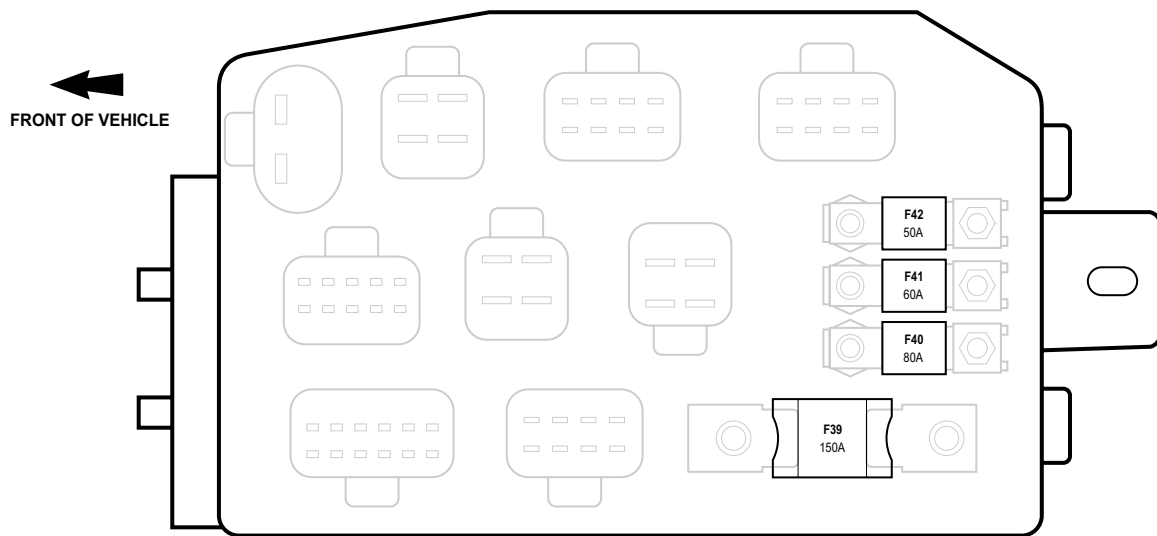

PASSENGER JUNCTION FUSE BOX (FRONT)

PASSENGER JUNCTION FUSE BOX (BACK)

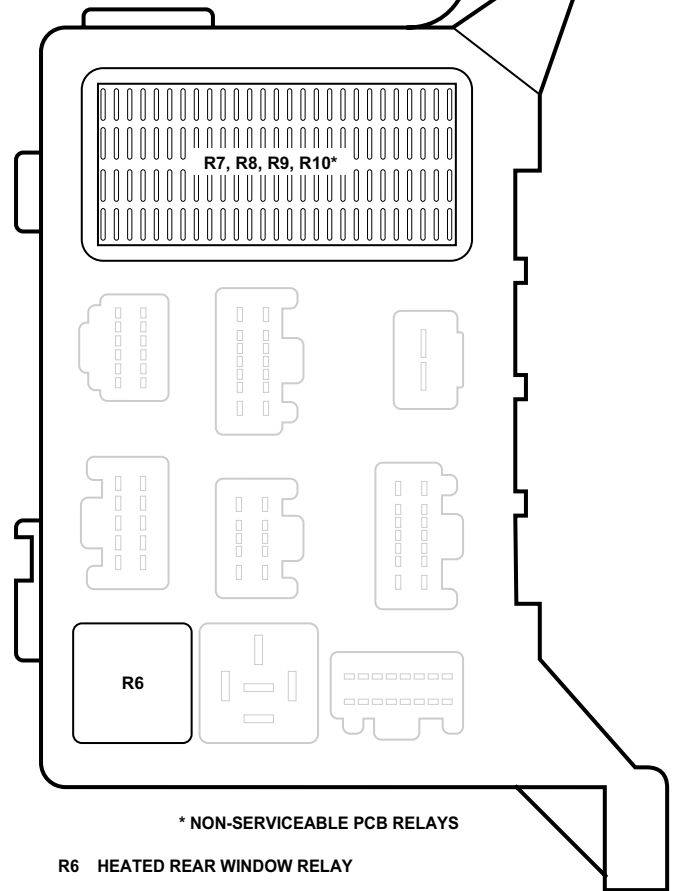
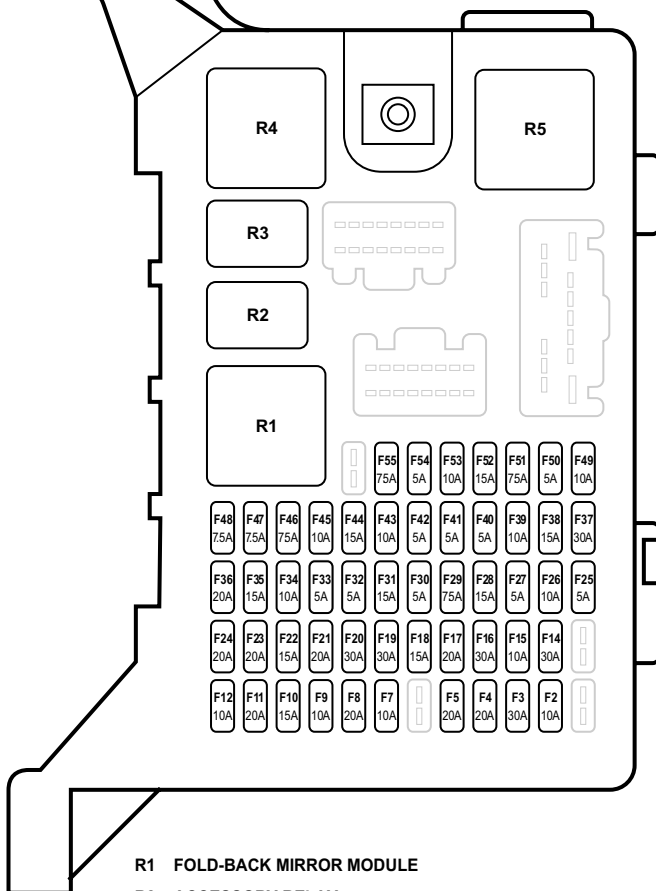

* NON-SERVICEABLE PCB RELAYS

- R1 FOLD-BACK MIRROR MODULE
- R2 ACCESSORY RELAY
- R3 REAR WIPER MOTOR RELAY (ESTATE / WAGON ONLY)
- R4 BLOWER MOTOR RELAY
- R5 PASSENGER JUNCTION FUSE BOX IGNITION RELAY

- R6 HEATED REAR WINDOW RELAY
- R7 THROTTLE MOTOR RELAY (2.5 L, 3.0 L)
FUEL PUMP RELAY (2.0 L)
- R8 NOT USED
- R9 REVERSE LAMPS RELAY
- R10 BATTERY SAVER RELAY

pw_dis_fuse_bot_4000625

POWER DISTRIBUTION FUSE BOX (BOTTOM)

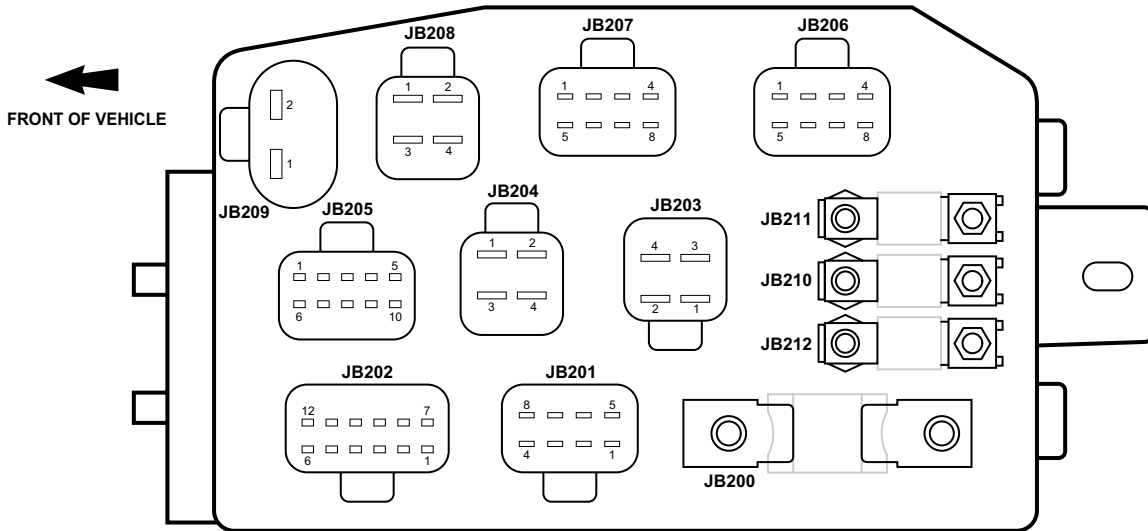

PASSENGER JUNCTION FUSE BOX (FRONT)

PASSENGER JUNCTION FUSE BOX (BACK)

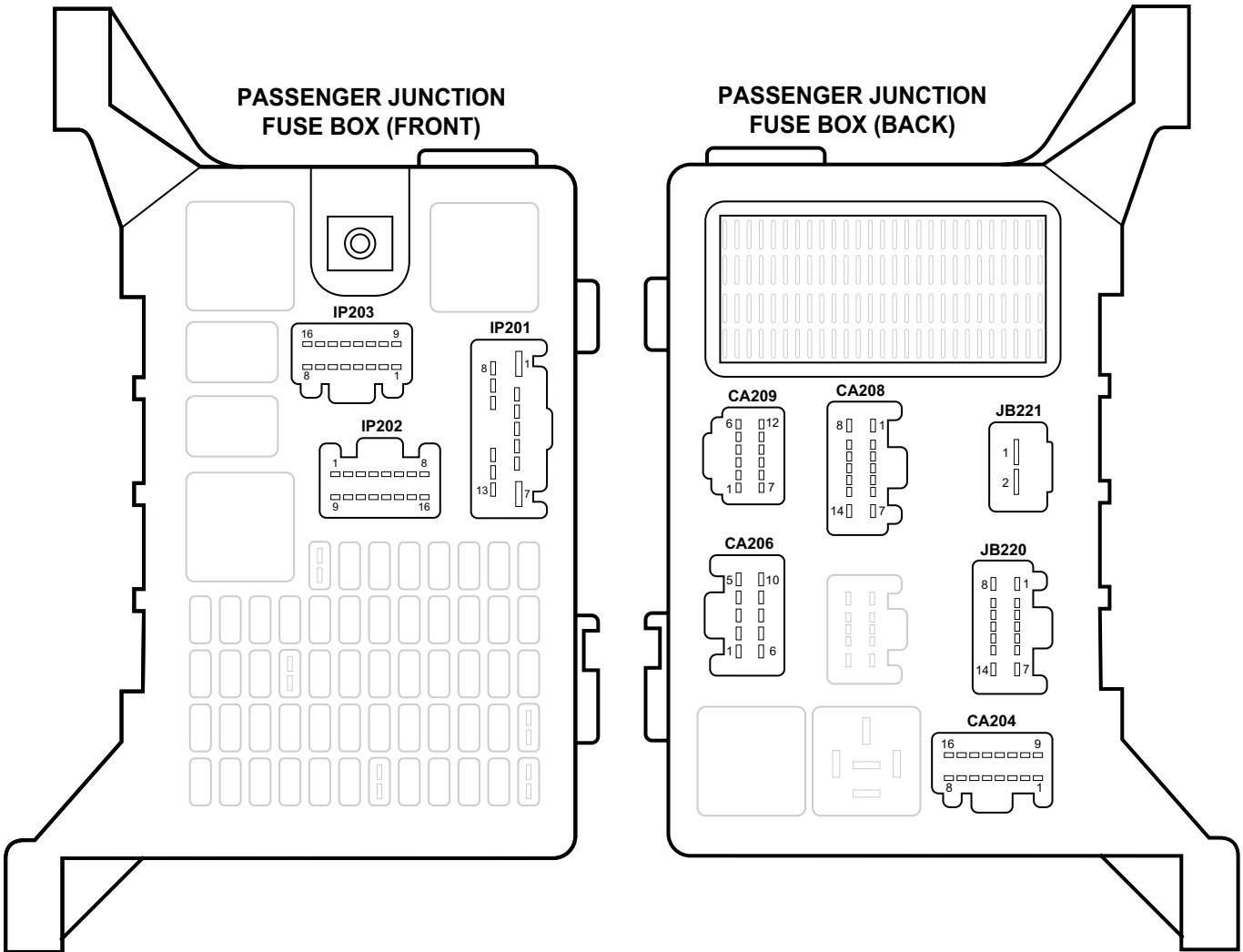

fuse_box_con_4000625

SEDAN (GASOLINE ENGINE SHOWN)

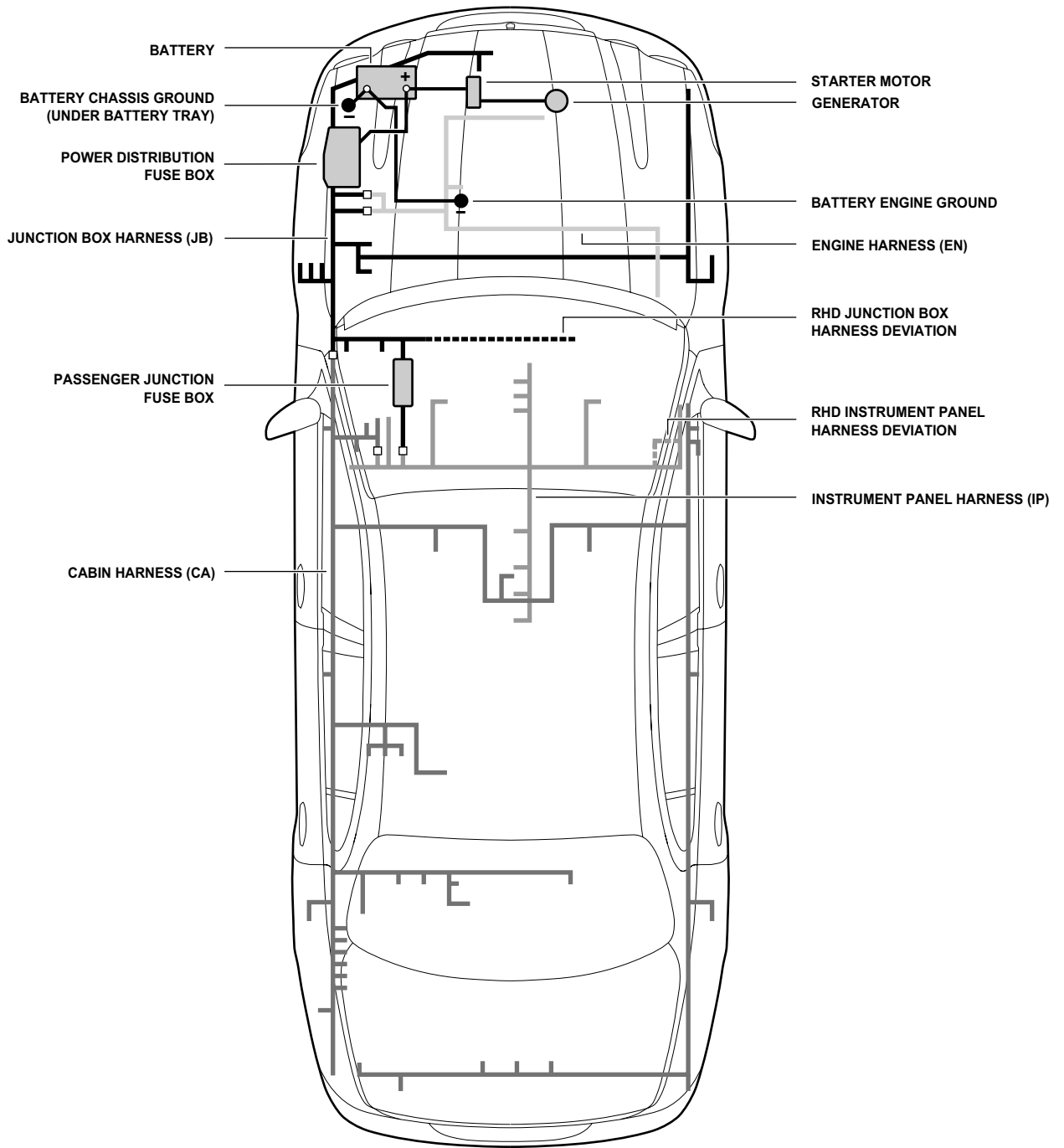

harn_fuse_box.loc_4000625

ESTATE / WAGON (GASOLINE ENGINE SHOWN)

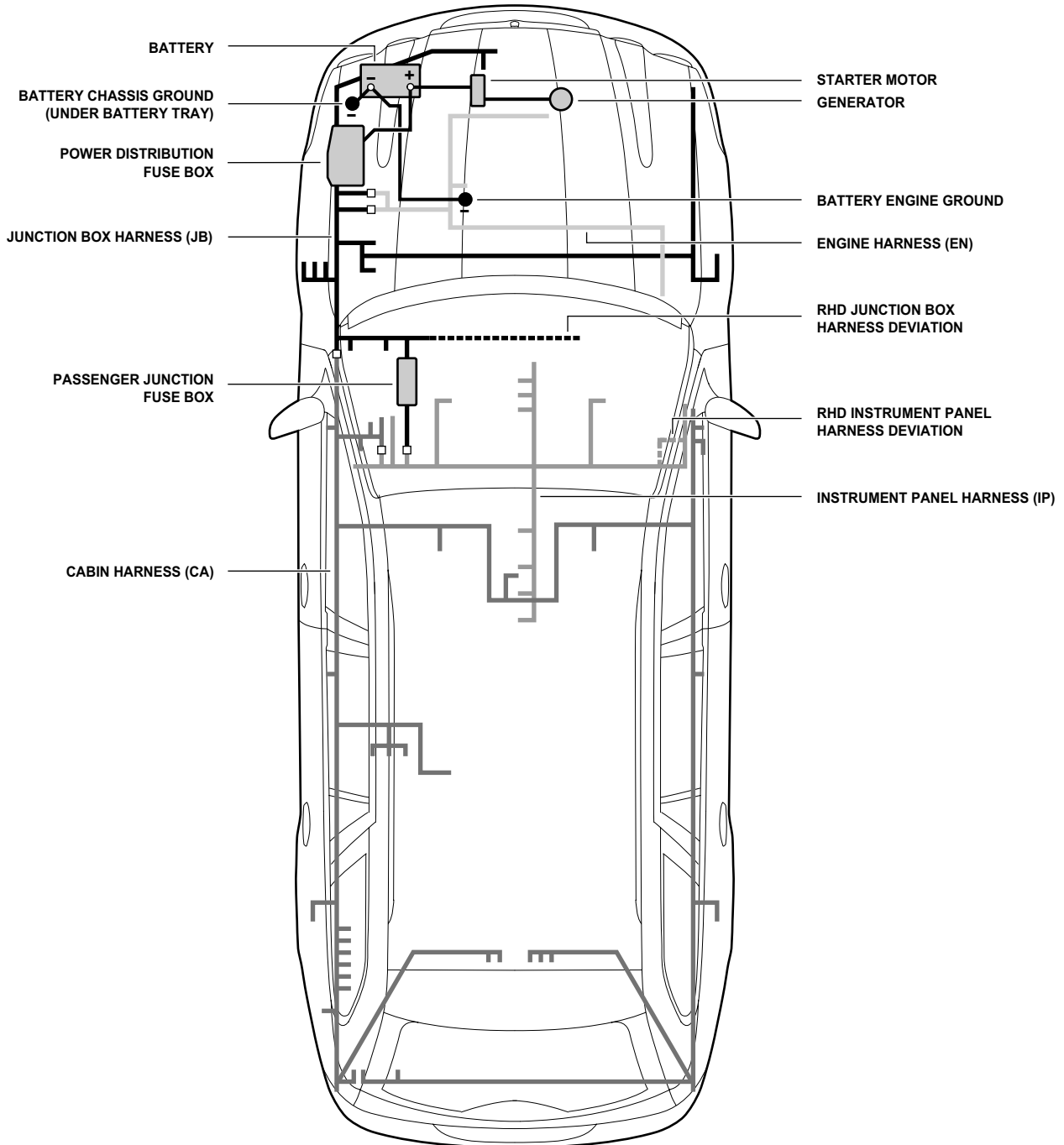

est_fuse_box_loc_4000625

SEDAN: GASOLINE ENGINE (LHD SHOWN)

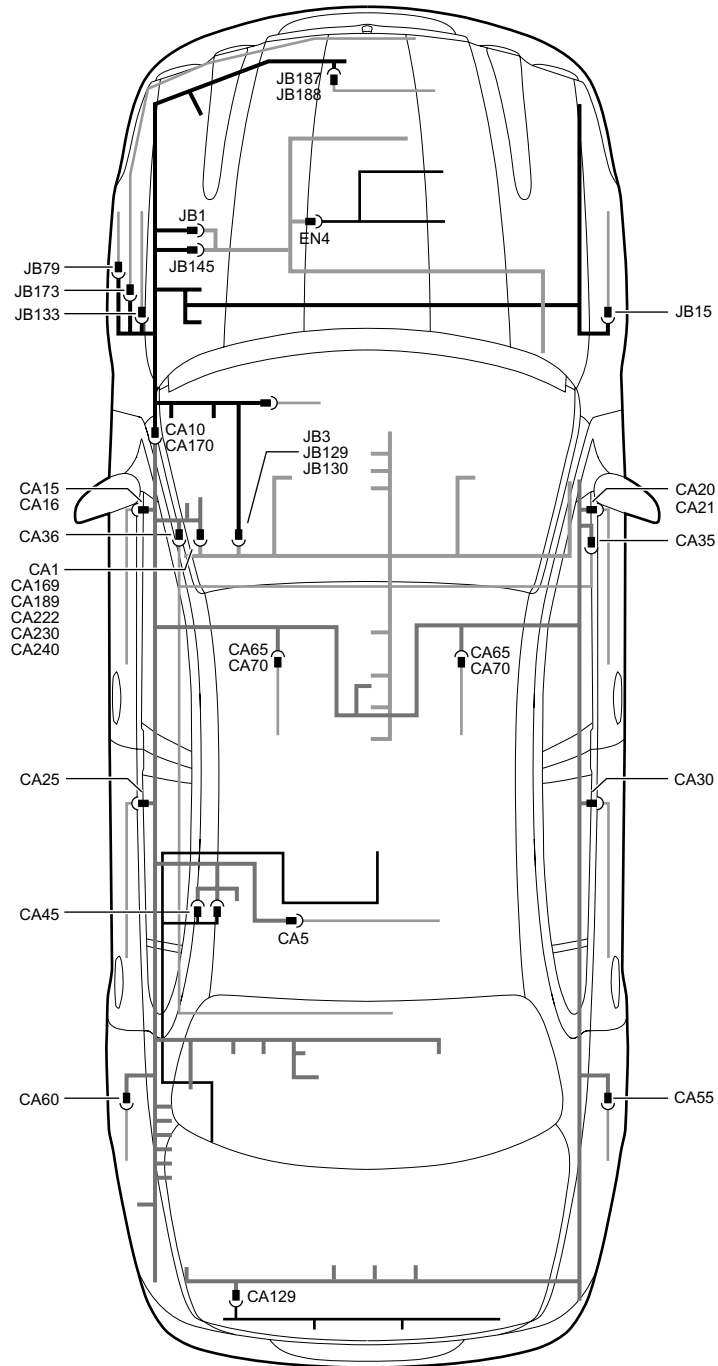

gas_harn_con_loc_4000625

SEDAN: DIESEL ENGINE (RHD SHOWN)

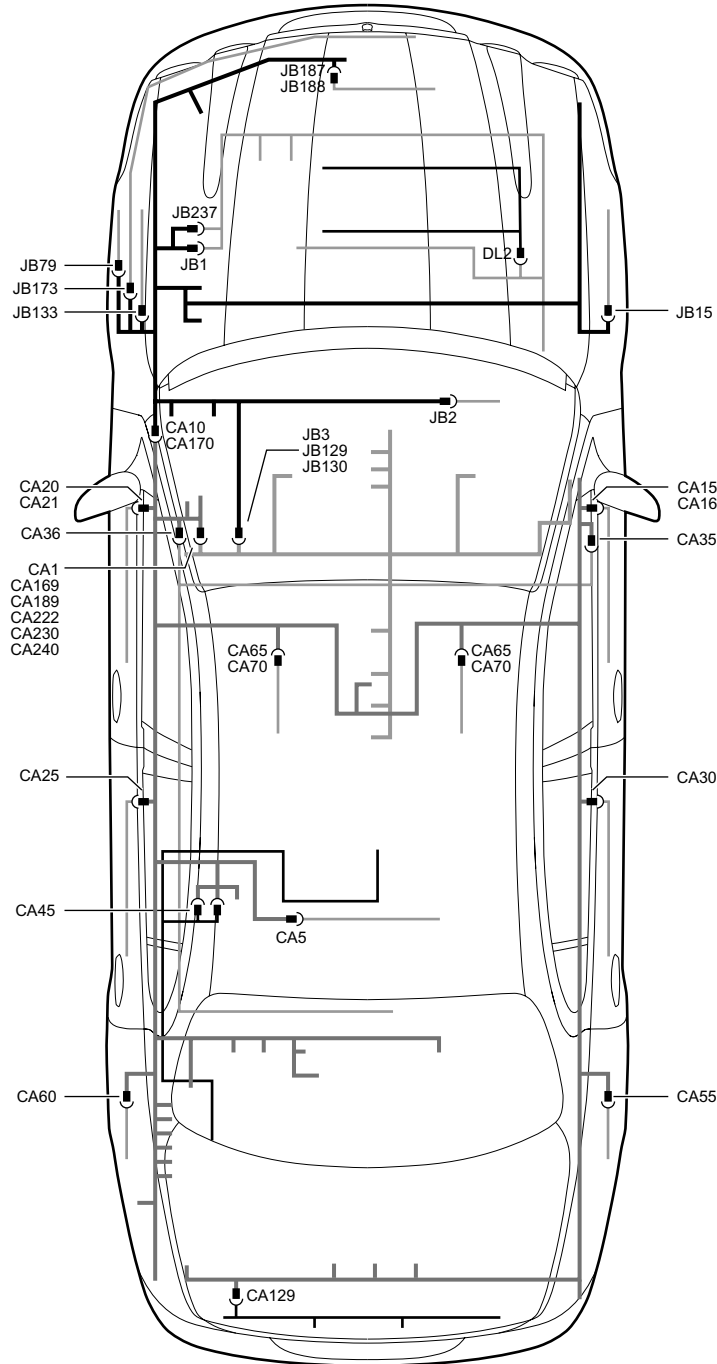

diesel_harn_con_loc_4000625

ESTATE / WAGON (RHD SHOWN)

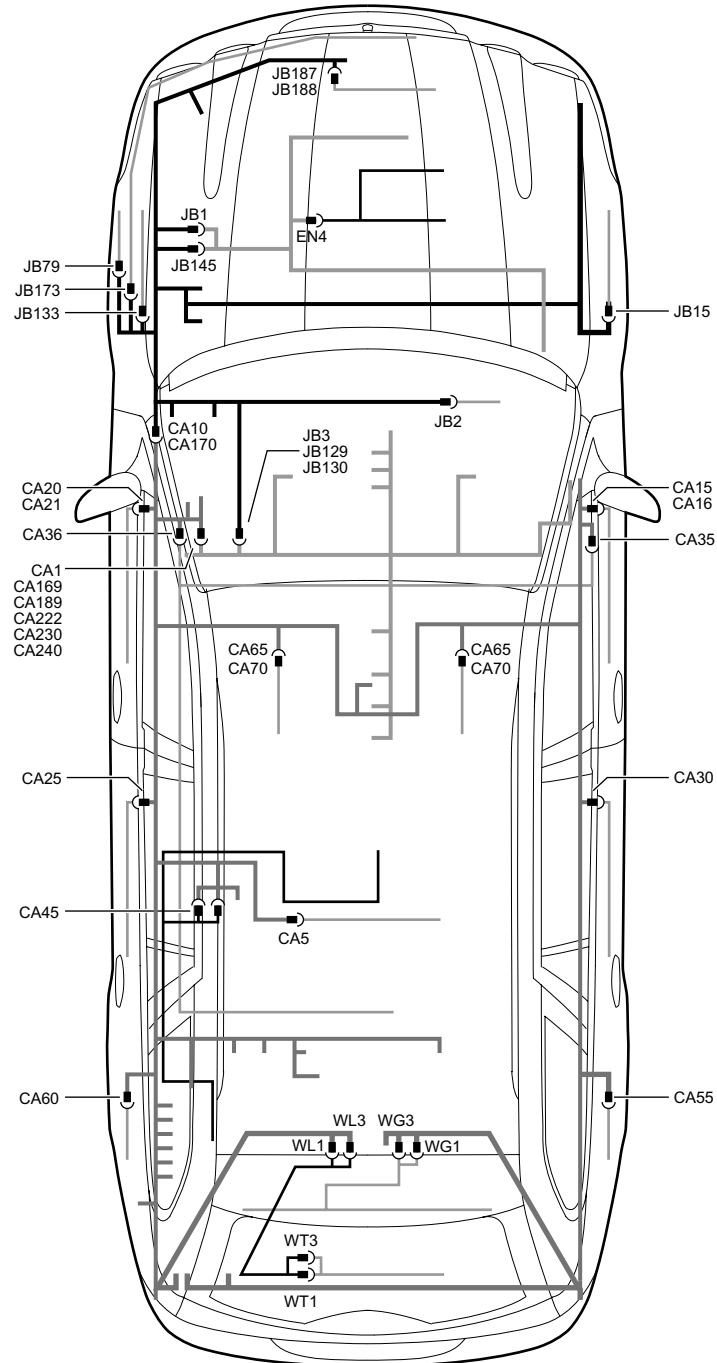

estate_harn_con_loc_400062

SEDAN SHOWN

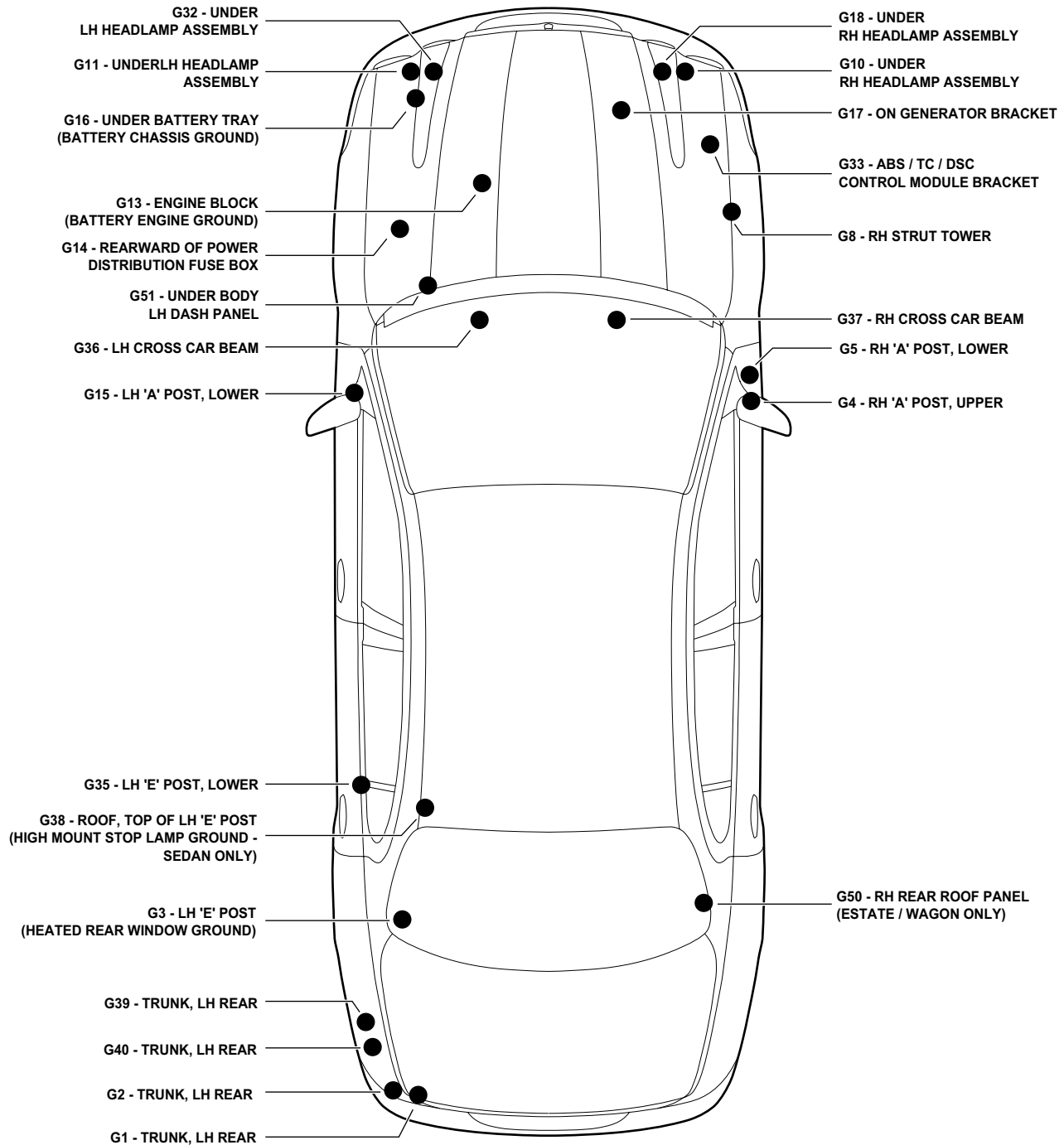

NOTE: UNIQUE GROUND STUDS ARE NOTED IN PARENTHESES.

grd_pt_loc_4000625

SEDAN

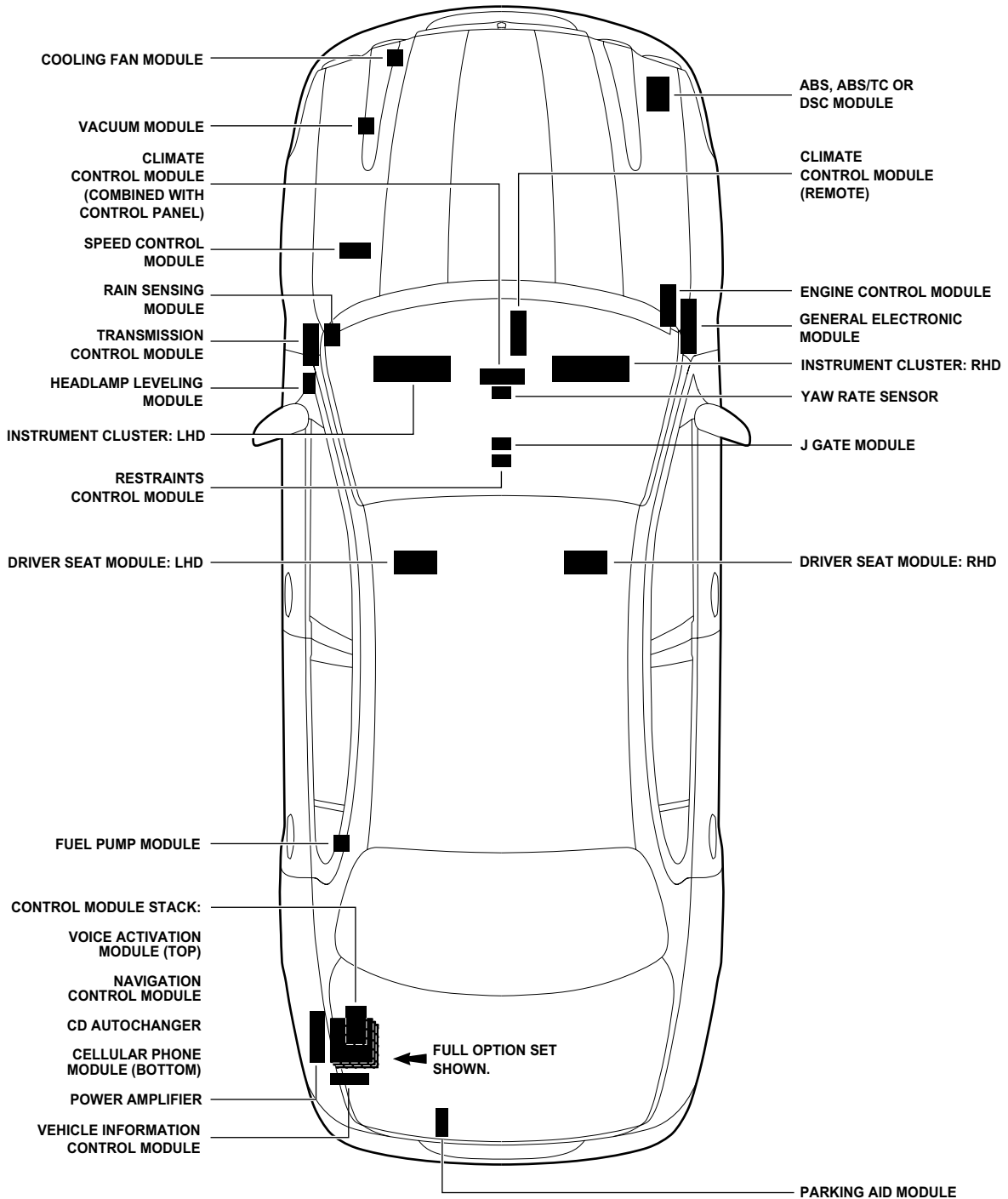

cntrl_mod_loc_4000625

ESTATE / WAGON

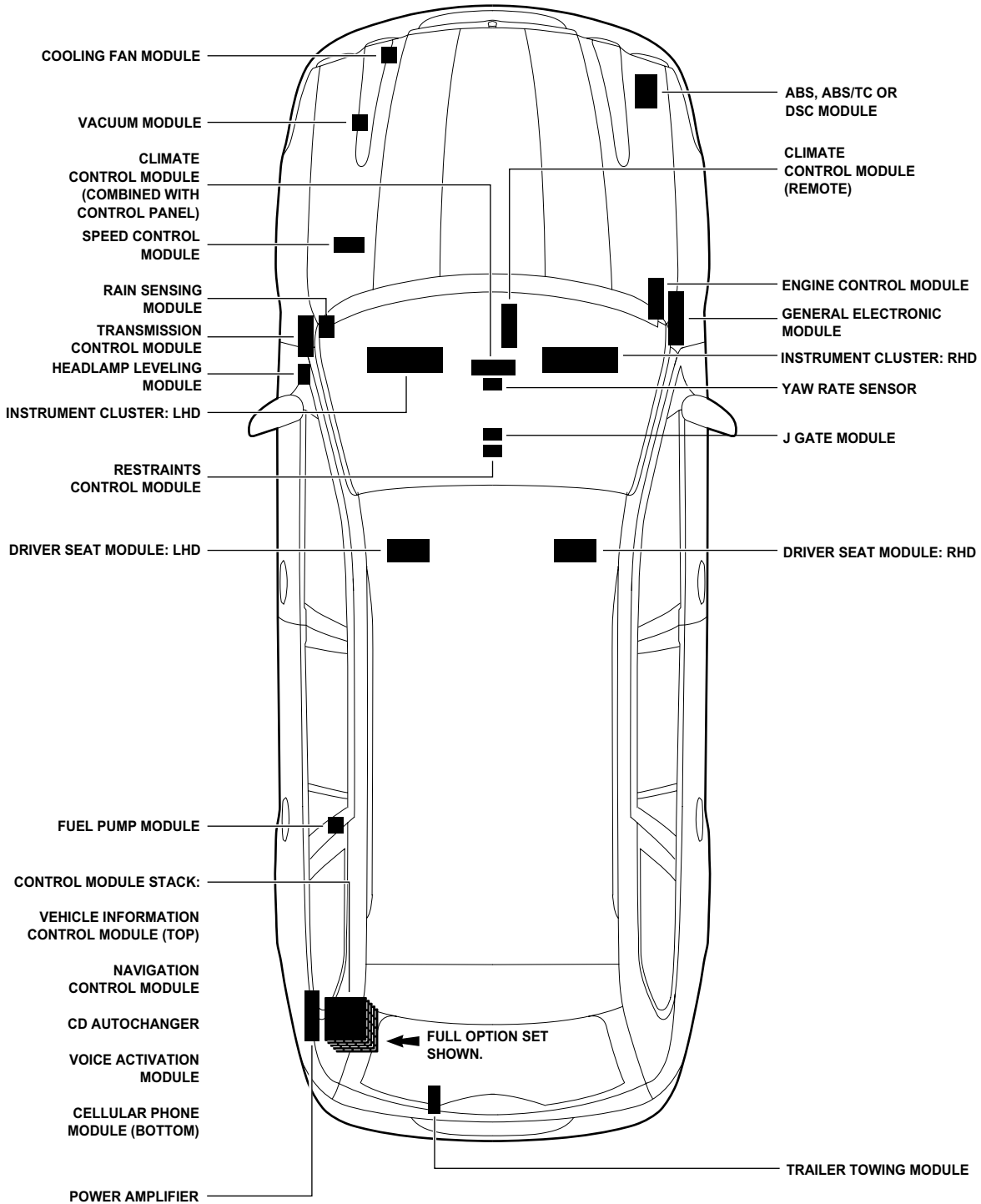

estate_cnt_mod_loc_4000625

ENGINE CONTROL MODULE - 2.5 L, 3.0 L

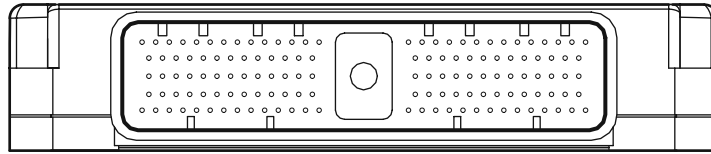

EN16 / 134-WAY / BLACK

107	108	109	110	111	112	113	114	115	116	117	118	119	120
Y	G	RW	G	B	-	BG	BO	BG	B	-	BO	BW	BW
81	82	83	84	85	86	87	88	89	90	91	92	93	
B	B	Y	G	-	-	GU	GW	GR	-	B	U	UY	
55	56	57	58	59	60	61	62	63	64	65	66	67	
GO	GO	-	-	-	-	GU	GW	GR	-	OG	UY	O	
29	30	31	32	33	34	35	36	37	38	39	40	41	
B	B	B	-	WG	BG	-	G	Y	OY	OY	B	GO	
1	2	3	4	5	6	7	8	9	10	11	12	13	14
RU	RU	-	B	B	Y	GO	GO	U	GU	-	OY	Y	-

121	122	123	124	125	126	127	128	129	130	131	132	133	134
WU	-	G	Y	-	-	BW	N	N	BR	YG	YG	BG	RW
94	95	96	97	98	99	100	101	102	103	104	105	106	
O	B	-	-	N	-	BG	-	R	Y	RG	W	R	
68	69	70	71	72	73	74	75	76	77	78	79	80	
G	N	UY	O	-	U	-	G	Y	-	Y	U	G	
42	43	44	45	46	47	48	49	50	51	52	53	54	
-	W	GW	BW	BW	YR	YG	-	U	WU	GR	RG	B	
15	16	17	18	19	20	21	22	23	24	25	26	27	28
-	-	B	B	BG	BG	-	NR	WG	WG	W	-	N	-

ENGINE CONTROL MODULE - 2.0 L

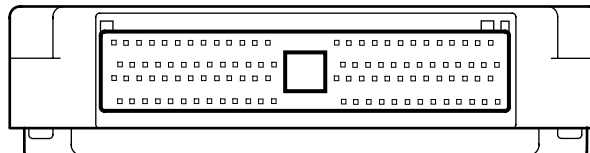

EN65 / 104-WAY / BLACK

79	80	81	82	83	84	85	86	87	88	89	90	91
Y	UY	O	-	-	WG	B	G	N	G	Y	-	B
53	54	55	56	57	58	59	60	61	62	63	64	65
N	N	BR	GW	GU	-	O	B	G	Y	GO	B	BG
27	28	29	30	31	32	33	34	35	36	37	38	39
N	-	BW	GW	BW	-	-	GO	U	GU	N	BG	W
1	2	3	4	5	6	7	8	9	10	11	12	13
BW	WU	BG	B	B	Y	U	OG	-	-	OY	YG	YG

92	93	94	95	96	97	98	99	100	101	102	103	104
BW	BW	BO	G	RW	G	R	GR	-	-	B	GO	RU
66	67	68	69	70	71	72	73	74	75	76	77	78
BO	BG	GO	B	-	OY	-	-	UY	B	GO	RU	B
40	41	42	43	44	45	46	47	48	49	50	51	52
GU	GW	GR	RG	WU	-	UY	U	B	-	G	Y	B
14	15	16	17	18	19	20	21	22	23	24	25	26
GU	GW	GR	G	B	B	BG	NR	WG	WG	-	G	Y

TRANSMISSION CONTROL MODULE - 16 BIT

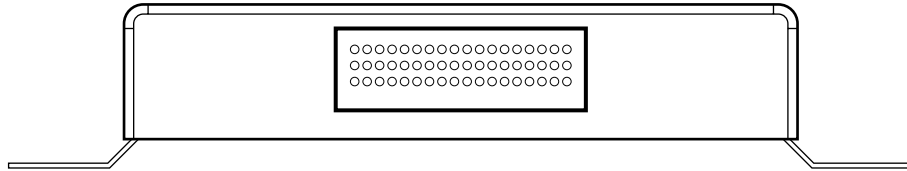

JB131 / 37-WAY / BLUE

18 R	17 B	16 O	15 B	14 N	13 G	12 G	11 -	10 W	9 B	8 R	7 O	6 UY	5 O	4 U	3 G	2 -	1 -
36 WU	35 -	34 Y	33 Y	32 -	31 -	30 U	29 -	28 -	27 Y	26 S	25 W	24 N	23 -	22 -	21 G	20 R	19 -
54 WU	53 Y	52 G	51 -	50 -	49 -	48 -	47 OY	46 BRD	45 BW	44 BRD	43 -	42 BRD	41 -	40 -	39 W	38 B	37 -

TRANSMISSION CONTROL MODULE - 32 BIT

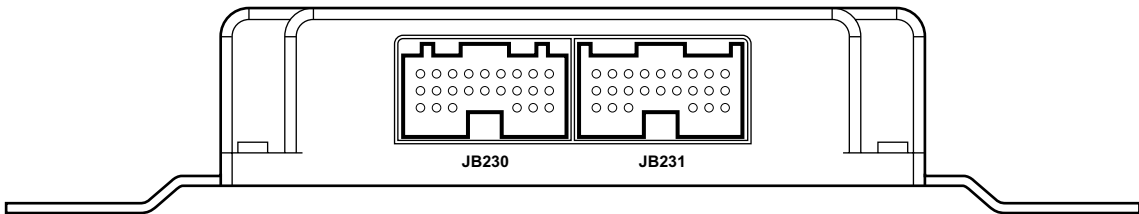

JB230 / 24-WAY / WHITE

1 R	2 G	3 O	4 B	5 Y	6 G	7 W	8 Y	9 -
10 WU	11 B	12 N	13 -	14 Y	15 G	16 -	17 -	18 U
19 WU	20 G	21 U			22 -	23 BRD	24 O	

JB231 / 24-WAY / GREY

25 B	26 BRD	27 R	28 UY	29 O	30 -	31 -	32 -	33 -
34 Y	35 S	36 W	37 -	38 N	39 G	40 -	41 OY	42 R
43 BW	44 BRD	45 -				46 -	47 W	48 B

DYNAMIC STABILITY CONTROL MODULE

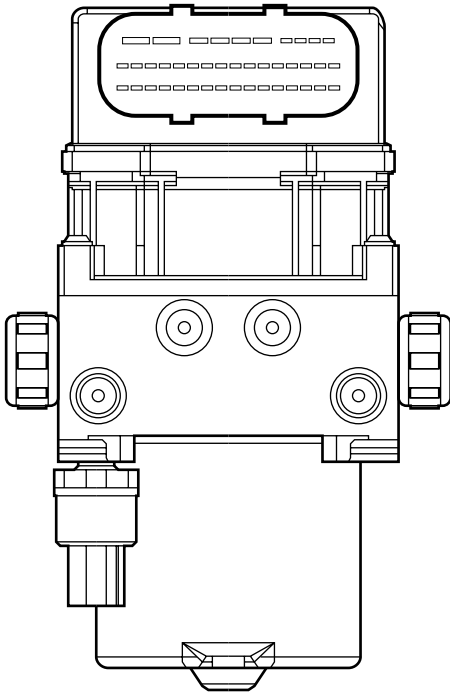

JB185 / 42-WAY / BLUE

1 B	2 R	3 -	4 -	5 B	6 R	7 -	8 -	9 -	10 -	11 -	12 W	13 GB	14 WU	15 NR	16 WR	17 -	18 -	19 -	20 -	21 U	22 -	23 GW	24 Y	25 B	26 WG
27 B	28 N	29 -	30 NG	31 WG	32 GO	33 -	34 -	35 -	36 -	37 -	38 -	39 GW	40 G	41 -	42 GB										

**ANTI-LOCK BRAKING SYSTEM MODULE OR
ANTI-LOCK BRAKING / TRACTION CONTROL MODULE**

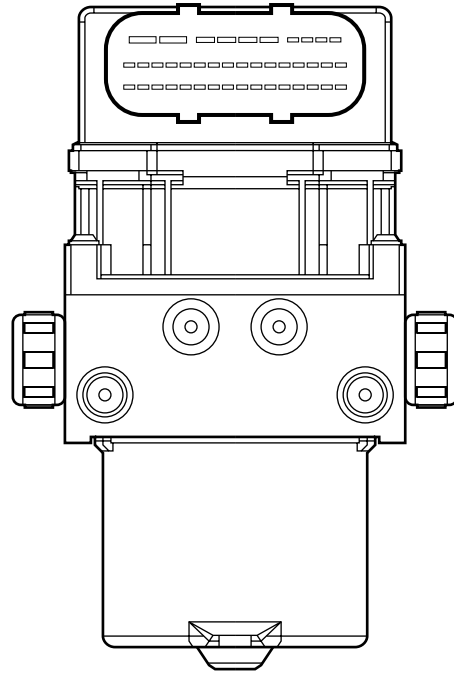

JB45 / 42-WAY BLUE (ABS)

1 B	2 R	3 -	4 -	5 B	6 R	7 -	8 -	9 -	10 -	11 -	12 W	13 GB	14 WU	15 NR	16 WR	17 -	18 -	19 -	20 -	21 -	22 -	23 GW	24 Y	25 -	26 -
27 -	28 N	29 -	30 NG	31 WG	32 GO	33 -	34 -	35 -	36 -	37 -	38 -	39 -	40 G	41 -	42 -										

JB197 / 42-WAY / BLUE (ABS/TC)

1 B	2 R	3 -	4 -	5 B	6 R	7 -	8 -	9 -	10 -	11 -	12 W	13 GB	14 WU	15 NR	16 WR	17 -	18 -	19 -	20 -	21 -	22 -	23 GW	24 Y	25 -	26 -
27 B	28 N	29 N	30 NG	31 WG	32 GO	33 -	34 -	35 -	36 -	37 -	38 -	39 -	40 G	41 -	42 -										

dyn_stab_crt_mod_4000625

CLIMATE CONTROL MODULE - AUTOMATIC (REMOTE)

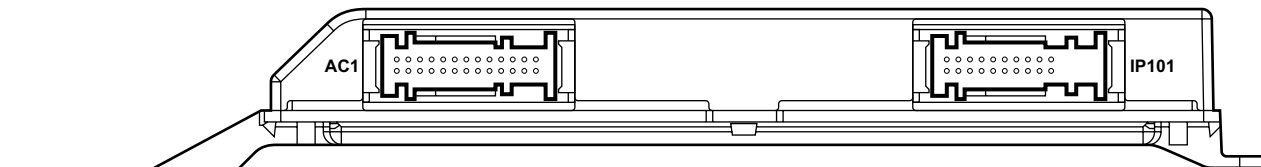

AC1 / 26-WAY / YELLOW

14 G	15 UY	16 B	17 -	18 -	19 -	20 GU	21 GB	22 OG	23 O	24 RW	25 RG	26 OY
1 -	2 -	3 -	4 GW	5 U	6 GR	7 GO	8 RU	9 R	10 WB	11 W	12 Y	13 R

IP101 / 26-WAY / WHITE

14 OG	15 B	16 W	17 B	18 -	19 B	20 G	21 W	22 Y	23 G
1 OY	2 WR	3 B	4 B	5 BW	6 B	7 BW	8 -	9 Y	10 G

CLIMATE CONTROL MODULE - AUTOMATIC (PANEL)

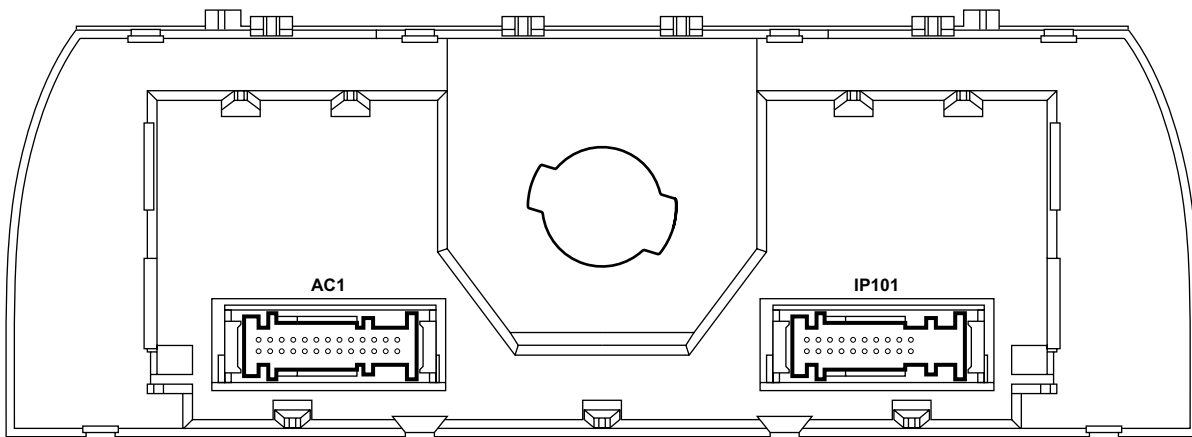

AC1 / 26-WAY / YELLOW

14 G	15 UY	16 B	17 -	18 -	19 -	20 GU	21 GB	22 OG	23 O	24 RW	25 RG	26 OY
1 -	2 -	3 -	4 GW	5 U	6 GR	7 GO	8 RU	9 R	10 WB	11 W	12 Y	13 R

IP101 / 26-WAY / WHITE

14 OG	15 B	16 W	17 B	18 -	19 B	20 G	21 W	22 Y	23 G
1 OY	2 WR	3 B	4 B	5 BW	6 B	7 BW	8 -	9 Y	10 G

CLIMATE CONTROL MODULE - MANUAL (PANEL)

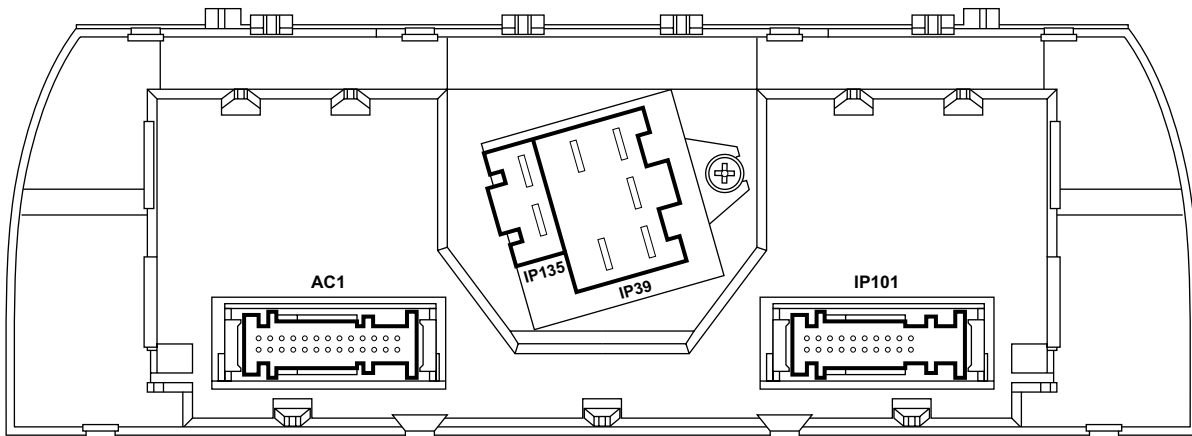

AC1 / 26-WAY / YELLOW

14	15	16	17	18	19	20	21	22	23	24	25	26
G	UY	B	-	-	-	GU	GB	OG	O	RW	RG	OY
1	2	3	4	5	6	7	8	9	10	11	12	13
-	-	-	GW	U	GR	GO	RU	R	WB	W	Y	R

IP135 / 2-WAY / GREY

2
B
1
BW

IP39 / 4-WAY / GREY

4	1
BK	GB
	2
	BO
6	3
BG	BR

IP101 / 26-WAY / WHITE

14	15	16	17	18	19	20	21	22	23
OG	B	-	-	-	-	G	-	Y	G
1	2	3	4	5	6	7	8	9	10
OY	WR	B	B	-	-	BW	-	Y	G

GENERAL ELECTRONIC MODULE

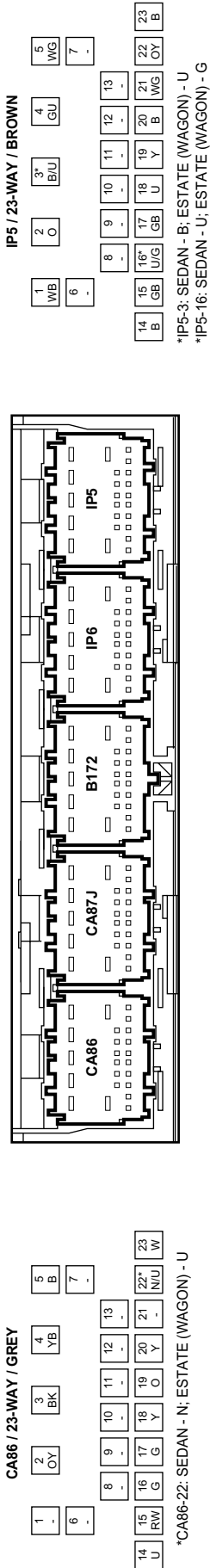

PARKING AID MODULE

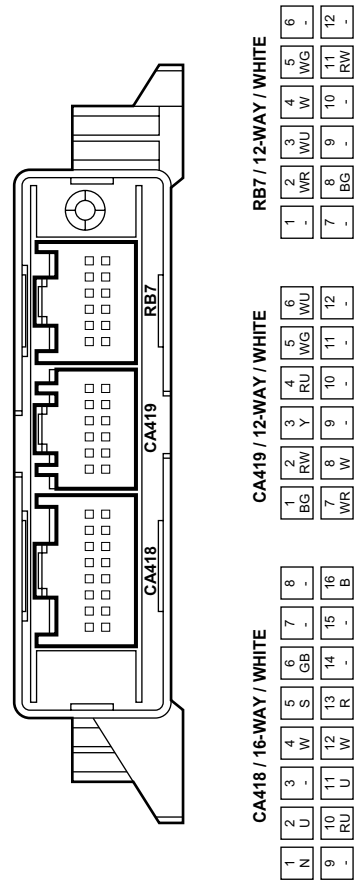

INSTRUMENT CLUSTER

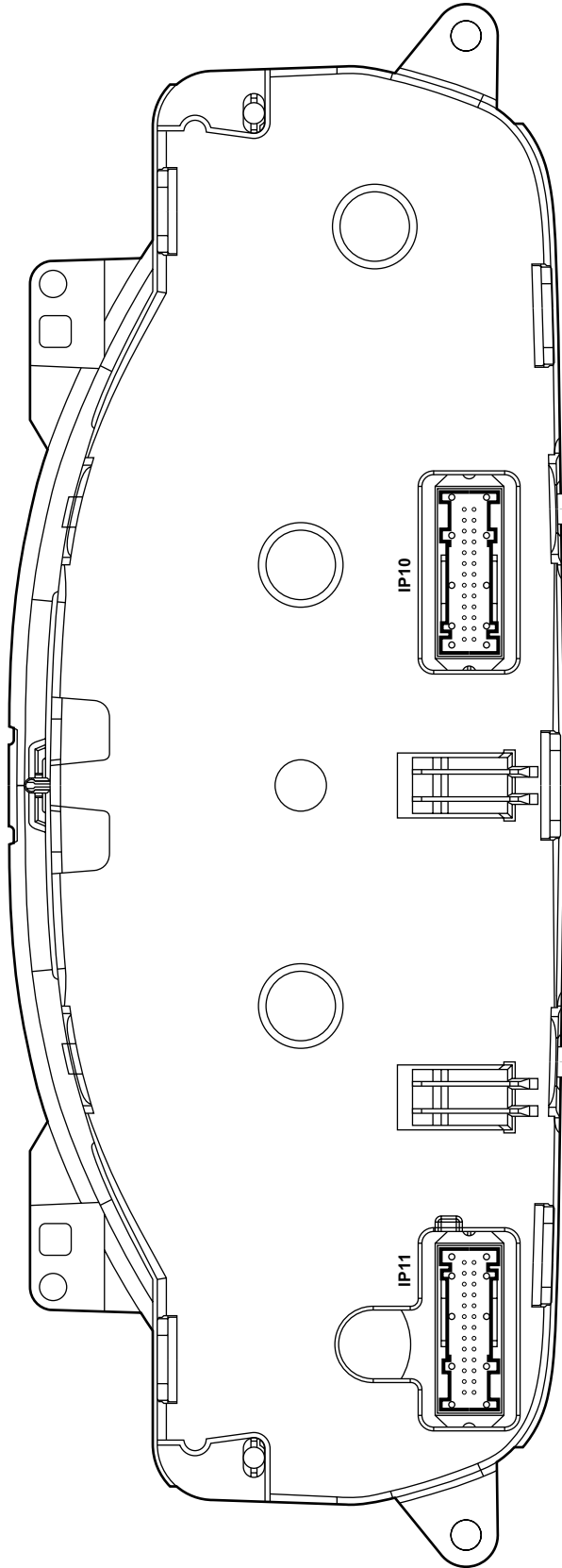

IP10 / 26-WAY WHITE

14	15	16	17	18	19	20	21	22	23	24	25	26
-	B	B	Y	G	U	WU	-	Y	U	Y	W	-
1	2	3	4	5	6	7	8	9	10	11	12	13
GB	OY	WG	O	B	G	WU	WB	B	U	B	B	GR

IP11 / 26-WAY / WHITE

13	12	11	10	9	8	7	6	5	4	3	2	1
YU	-	GR	-	-	B	B	OG	-	B	GB	-	-
26	25	24	23	22	21	20	19	18	17	16	15	14
-	R	GR	U	-	O	-	U	-	OY	-	OG	-

