

Passenger Air Bag Module 76.73.37

Removal

1.  **WARNING:**
AN RCM MODULE ONLY REQUIRES REPLACEMENT IF THE SYSTEM HAS INCURRED FIVE SEPARATE DEPLOYMENTS. AT NO TIME CHANGE AN RCM FOR LESS THAN FIVE SEPARATE DEPLOYMENTS.

 **WARNING:**
ALWAYS WEAR SAFETY GLASSES WHEN REPAIRING AN AIR BAG SRS VEHICLE AND WHEN HANDLING AN AIR BAG MODULE. FAILURE TO FOLLOW THIS INSTRUCTION MAY RESULT IN PERSONAL INJURY.

 **WARNING:**
CARRY A LIVE AIR BAG MODULE WITH THE AIR BAG AND TRIM COVER POINTED AWAY FROM YOUR BODY. THIS WILL REDUCE THE RISK OF INJURY IN THE EVENT OF AN ACCIDENTAL DEPLOYMENT. FAILURE TO FOLLOW THIS INSTRUCTION MAY RESULT IN PERSONAL INJURY.

 **WARNING:**
DO NOT SET A LIVE AIR BAG MODULE DOWN WITH THE TRIM COVER FACE DOWN. FAILURE TO FOLLOW THIS INSTRUCTION MAY RESULT IN PERSONAL INJURY.

 **WARNING:**
AFTER DEPLOYMENT, THE AIR BAG SURFACE CAN CONTAIN DEPOSITS OF SODIUM HYDROXIDE, A PRODUCT OF THE GAS GENERANT COMBUSTION THAT IS IRRITATING TO THE SKIN. WASH YOUR HANDS WITH SOAP AND WATER AFTERWARDS. FAILURE TO FOLLOW THIS INSTRUCTION MAY RESULT IN PERSONAL INJURY.

 **WARNING:**
NEVER PROBE THE CONNECTORS ON THE AIR BAG MODULE. DOING SO MAY RESULT IN AIR BAG DEPLOYMENT. FAILURE TO FOLLOW THIS INSTRUCTION MAY RESULT IN PERSONAL INJURY.

 **WARNING:**
AIR BAG MODULES WITH DISCOLORED OR DAMAGED TRIM COVERS MUST BE REPLACED.

 **WARNING:**
VEHICLE SENSOR ORIENTATION IS CRITICAL FOR CORRECT SYSTEM OPERATION. IF A VEHICLE EQUIPPED WITH AN AIR BAG SRS IS INVOLVED IN A COLLISION, INSPECT THE SENSOR MOUNTING BRACKET AND WIRING PIGTAIL FOR DEFORMATION. IF DAMAGED, INSTALL A NEW SENSOR WHETHER OR NOT THE AIR BAG IS DEPLOYED. IF THE BODY WORK IS DAMAGED THIS WILL HAVE TO BE ADDRESSED.

 **WARNING:**
TO AVOID ACCIDENTAL DEPLOYMENT AND POSSIBLE PERSONAL INJURY, THE BACKUP POWER SUPPLY MUST BE DEPLETED BEFORE REPAIRING OR REPLACING ANY AIR BAG SRS COMPONENTS. TO DEplete THE BACKUP POWER SUPPLY ENERGY, DISCONNECT THE BATTERY GROUND CABLE AND WAIT ONE MINUTE. FAILURE TO FOLLOW THIS INSTRUCTION MAY RESULT IN PERSONAL INJURY.

NOTE:
Repair is made by replacement only. If a part is replaced and the new part does not correct the condition, install the original part and carry out the diagnostic procedure again.

2003 X-TYPE - Supplemental Restraint System - 501-20B

NOTE:

When installing a new air bag module, a prepaid return postcard is provided with the replacement air bag module. The serial number for the new part and the vehicle identification number (VIN) must be recorded and sent to Jaguar Cars Ltd.

Disconnect the battery ground cable. For additional information, refer to <<414-01>>.

2. Lower and extend the steering column to its maximum rearward position.

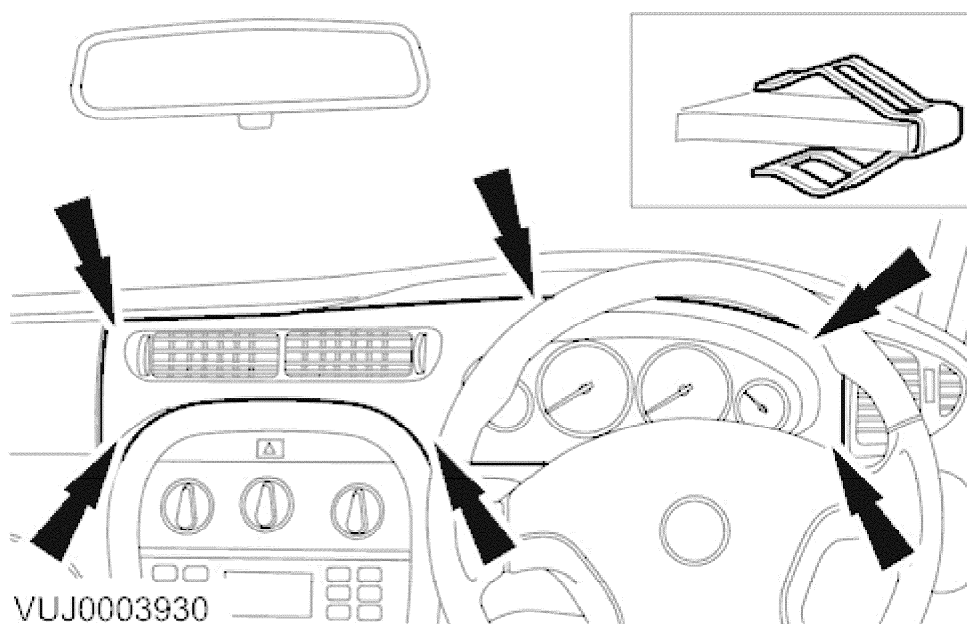

3. Remove the instrument cluster and vent finish panel.

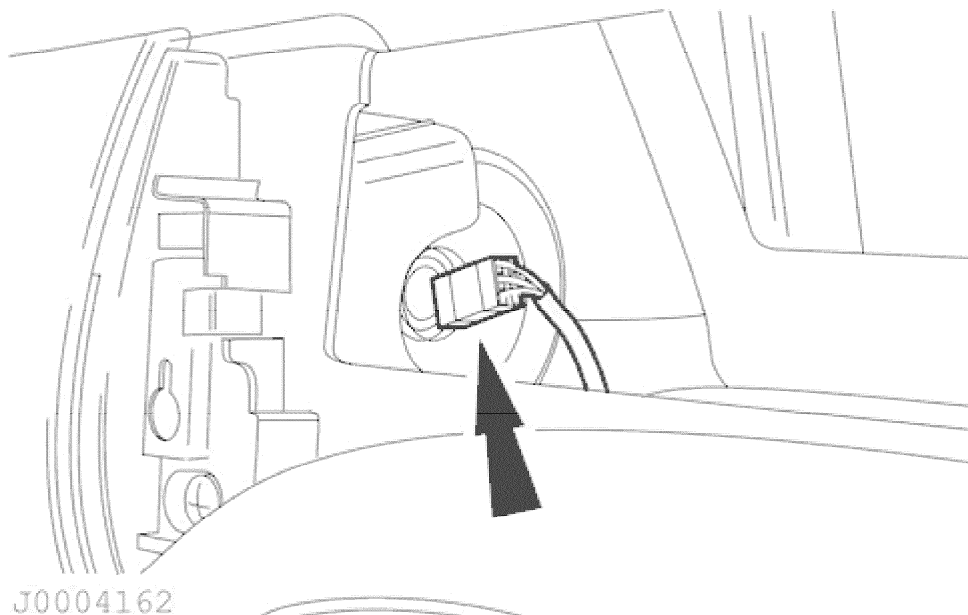

4.  **WARNING:**
DISCONNECT THE PASSENGER AIR BAG MODULE RIGHT-HAND ELECTRICAL CONNECTOR BEFORE THE LEFT-HAND ELECTRICAL CONNECTOR. FAILURE TO FOLLOW THESE INSTRUCTIONS MAY RESULT IN PERSONAL INJURY.

Disconnect the passenger air bag module right-hand electrical connector.

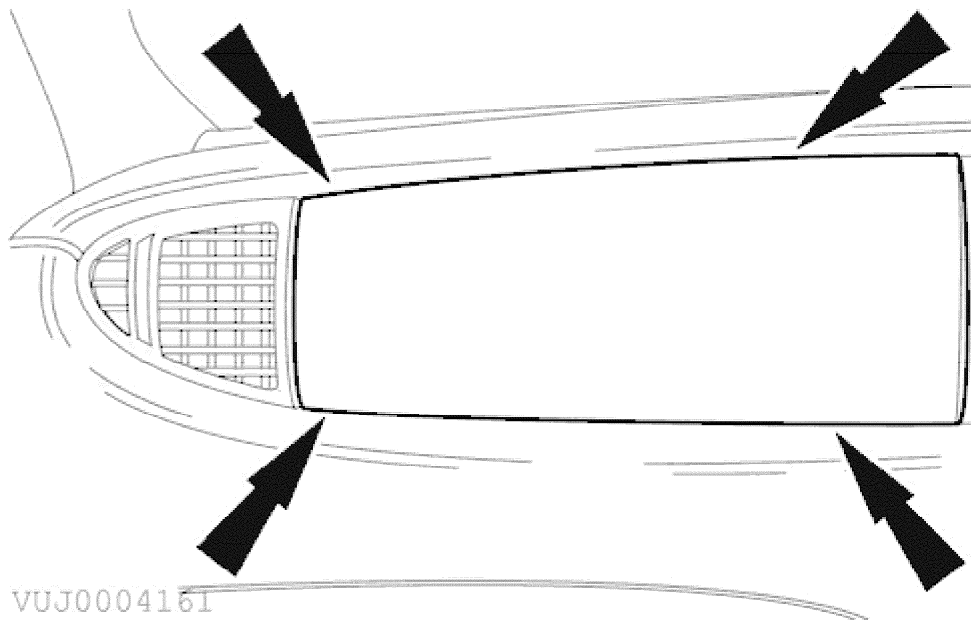

VUJ0004161

5. Detach the passenger finish panel.

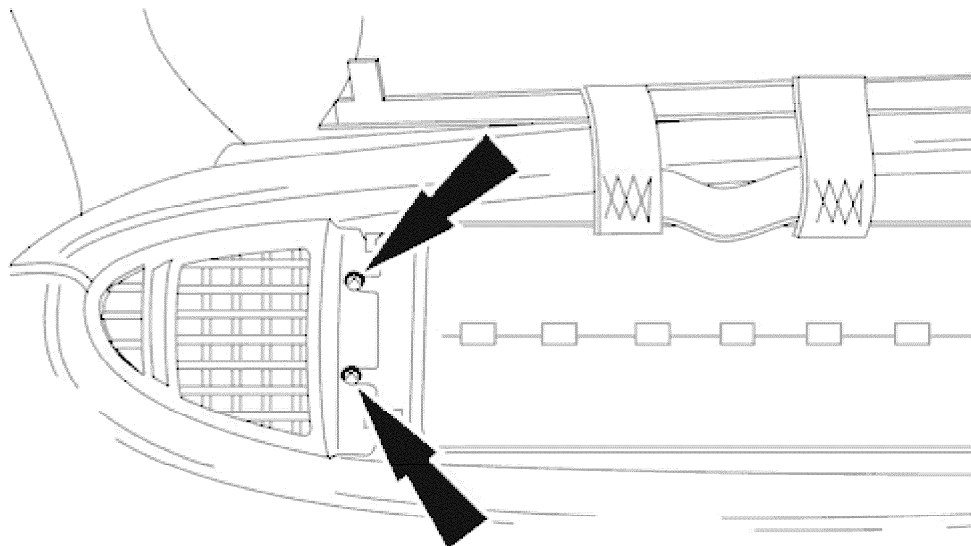

VUJ0004164

6. Remove the passenger air vent.

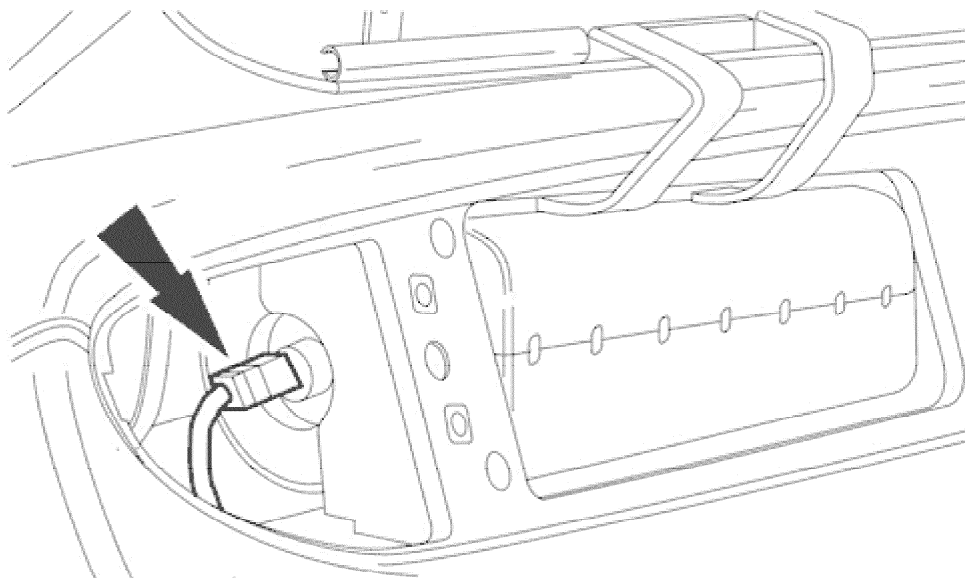

VUJ0004163

7.  **WARNING:**
MAKE SURE THE PASSENGER AIR BAG MODULE RIGHT-HAND ELECTRICAL CONNECTOR HAS BEEN DISCONNECTED. FAILURE TO FOLLOW THESE INSTRUCTIONS MAY RESULT IN PERSONAL INJURY.

Disconnect the passenger air bag module left-hand electrical connector.

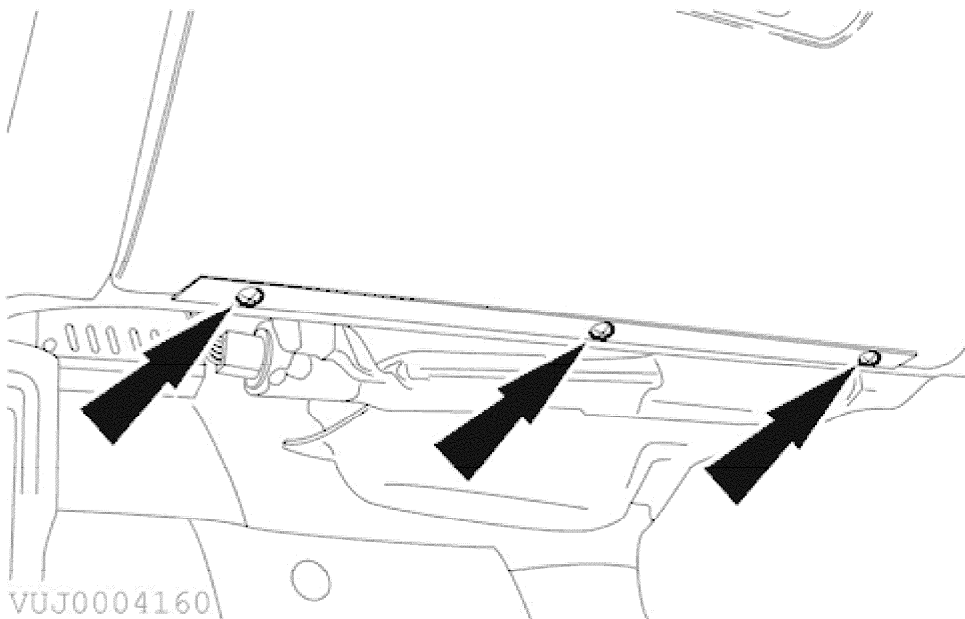

VUJ0004160

8. Remove the passenger compartment hinge retaining screws.

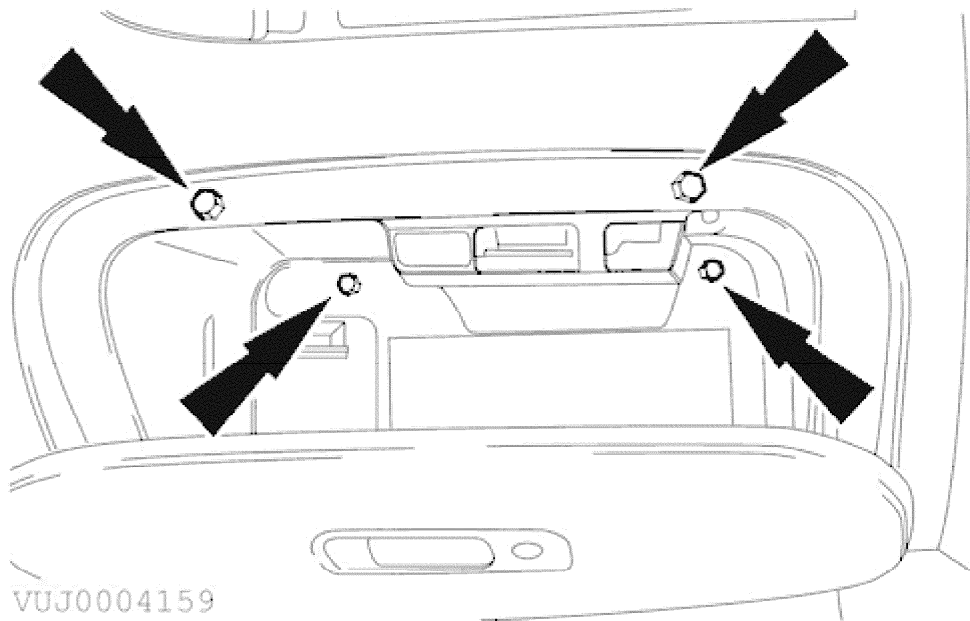

9. Remove the passenger compartment.

- Remove the passenger compartment retaining screws.

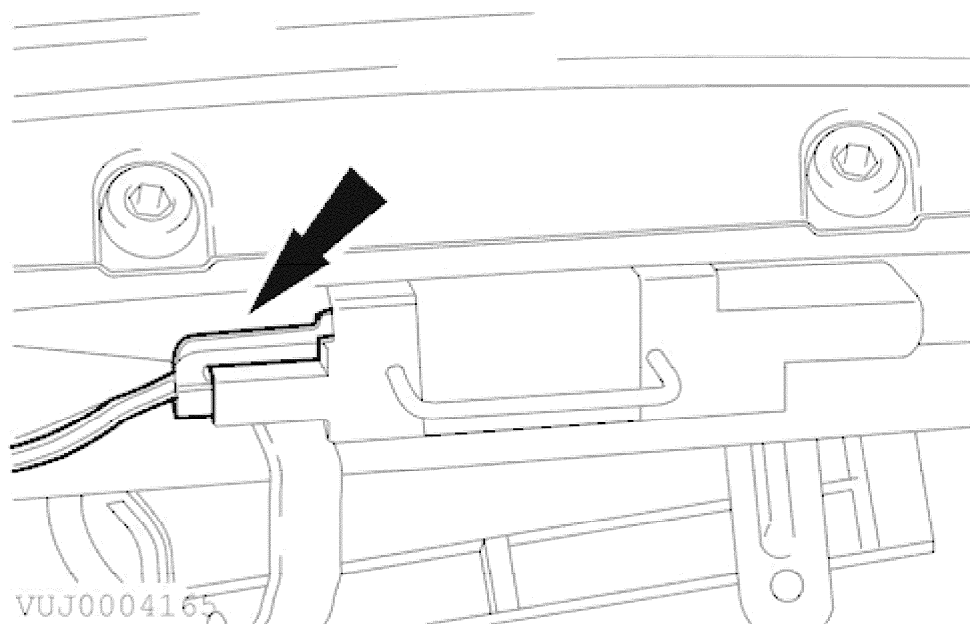

10. Disconnect the passenger compartment lamp electrical connector.

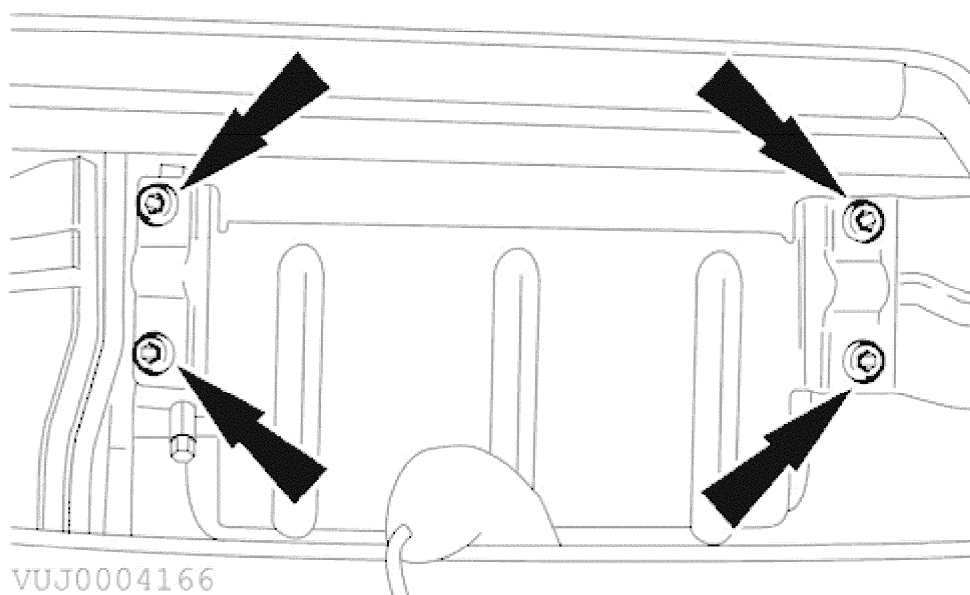

11. **NOTE:**

In no circumstances should the air bag be removed from the re-action can.

NOTE:

Support the passenger air bag module.

Remove the passenger air bag module retaining bolts.

Installation

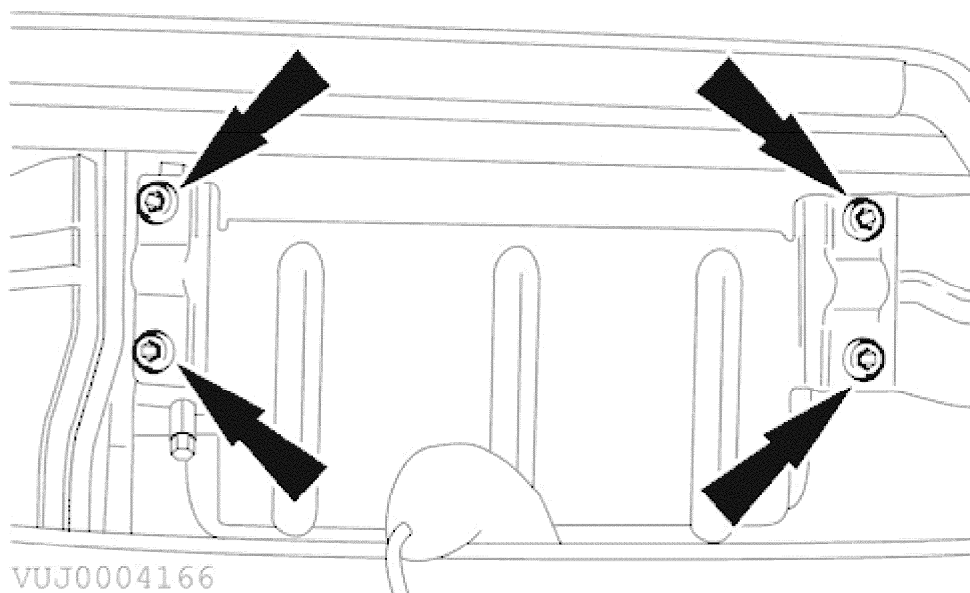

1.  **WARNING:**

MAKE SURE THE PASSENGER AIR BAG MODULE LEFT-HAND ELECTRICAL CONNECTOR IS CONNECTED BEFORE THE RIGHT-HAND ELECTRICAL CONNECTOR. FAILURE TO FOLLOW THESE INSTRUCTIONS MAY RESULT IN PERSONAL INJURY.

 **WARNING:**

AN RCM MODULE ONLY REQUIRES REPLACEMENT IF THE SYSTEM HAS INCURRED FIVE SEPARATE DEPLOYMENTS. AT NO TIME CHANGE AN RCM FOR LESS THAN FIVE SEPARATE

DEPLOYMENTS.



WARNING:

ALWAYS WEAR SAFETY GLASSES WHEN REPAIRING AN AIR BAG SRS VEHICLE AND WHEN HANDLING AN AIR BAG MODULE. FAILURE TO FOLLOW THIS INSTRUCTION MAY RESULT IN PERSONAL INJURY.



WARNING:

CARRY A LIVE AIR BAG MODULE WITH THE AIR BAG AND DEPLOYMENT DOOR POINTED AWAY FROM YOUR BODY. THIS WILL REDUCE THE RISK OF INJURY IN THE EVENT OF AN ACCIDENTAL DEPLOYMENT.



WARNING:

NEVER PROBE THE CONNECTORS ON THE AIR BAG MODULE. DOING SO MAY RESULT IN AIR BAG DEPLOYMENT. FAILURE TO FOLLOW THIS INSTRUCTION MAY RESULT IN PERSONAL INJURY.

NOTE:

Repair is made by replacement only. If a part is replaced and the new part does not correct the condition, install the original part and carry out the diagnostic procedure again.

NOTE:

Make sure to tighten the retaining bolts to the correct specification.

To install, reverse the removal procedure.

- Tighten to 9 Nm.