

Electronic Engine Controls - 2.0L NA V6 - AJV6/2.5L NA V6 - AJV6/3.0L NA V6 - AJ27 - Electronic Engine Controls

Description and Operation

2.0L Engine

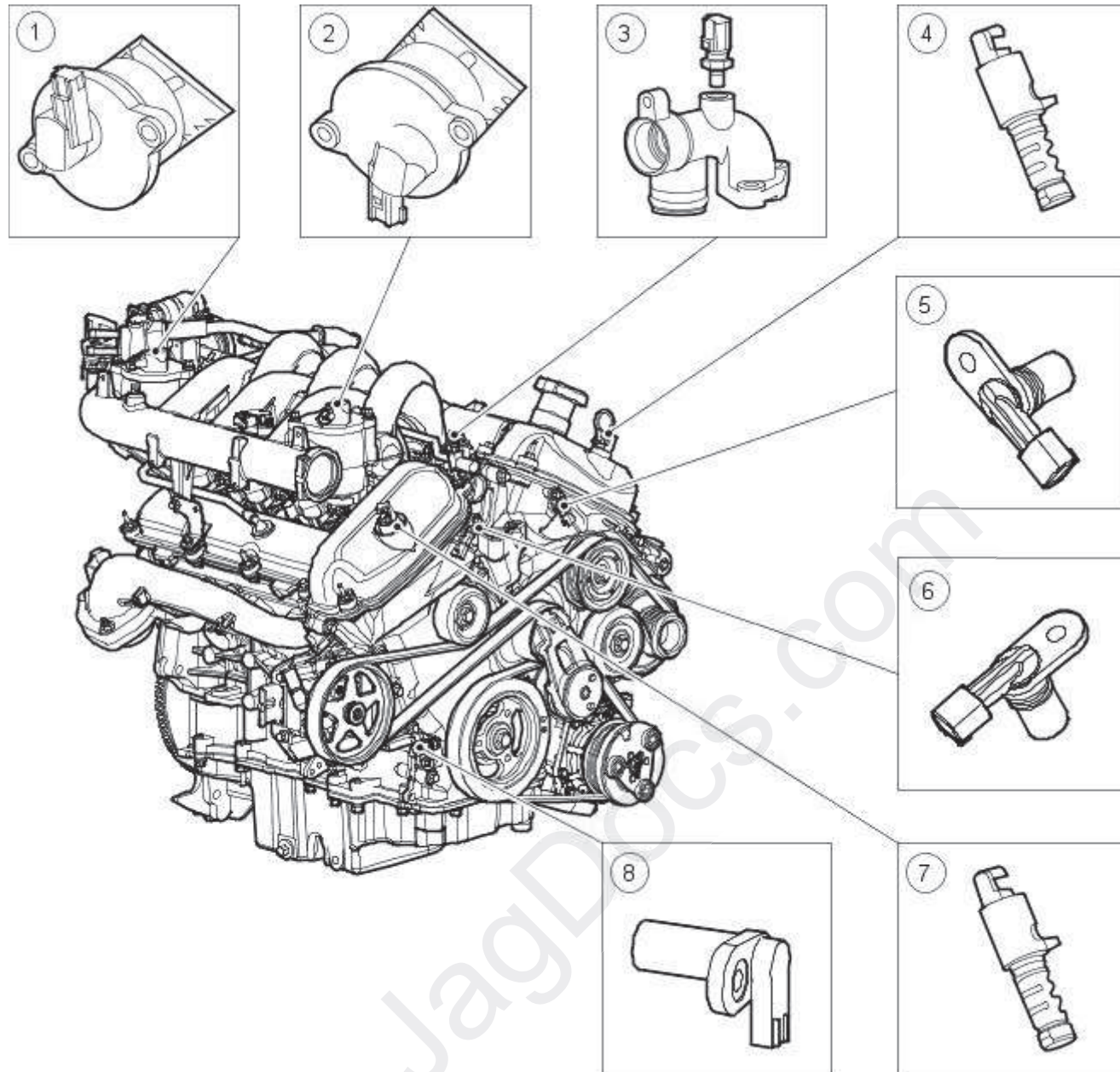

E30812

Item	Part Number	Description
1	—	Intake Manifold Tuning (IMT) Valve - upper
2	—	Intake Manifold Tuning (IMT) Valve - lower
3	—	Engine Coolant Temperature (ECT) Sensor
4	—	Variable Camshaft Timing Oil Control Solenoid LH
5	—	Camshaft Position (CMP) Sensor LH
6	—	Camshaft Position (CMP) Sensor RH
7	—	Variable Camshaft Timing Oil Control Solenoid RH
8	—	Crankshaft Position (CKP) Sensor

2.5L and 3.0L Engine