

JF506E / 5F31J / 09A / JA5A-EL
FORD, MAZDA, VOLKSWAGEN, ROVER, SEAT

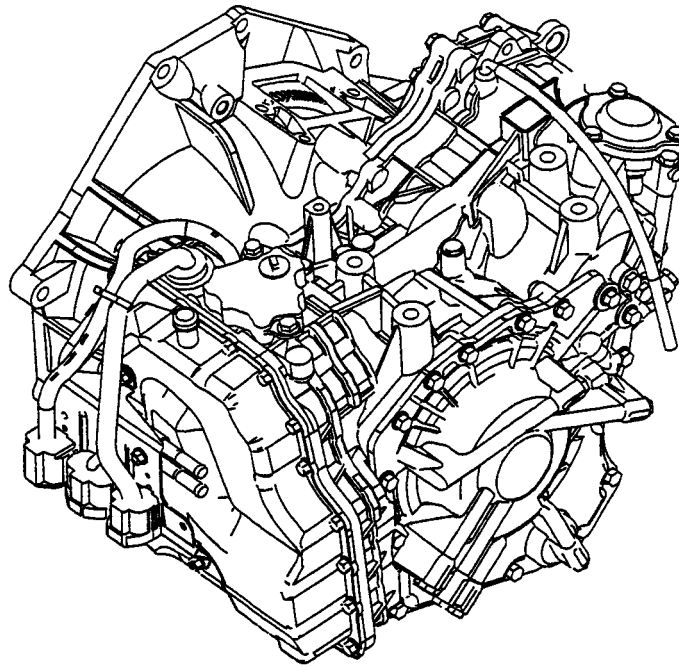

MPV Van, Mondeo, Galaxy, X-type,
Freelander, 75 / 45, Sharan, Jetta / Golf, Alhambra

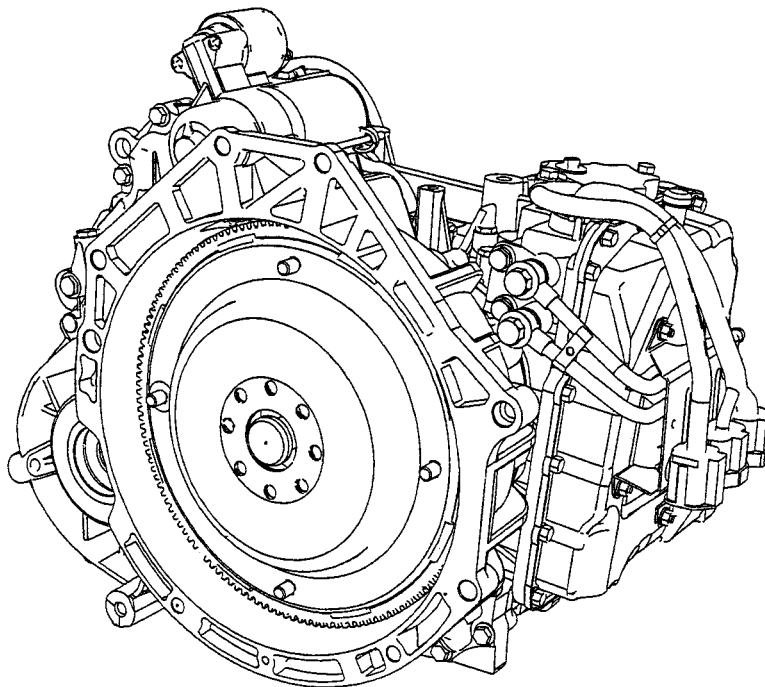

Note: Every manufacturer has a different bell and case configuration.

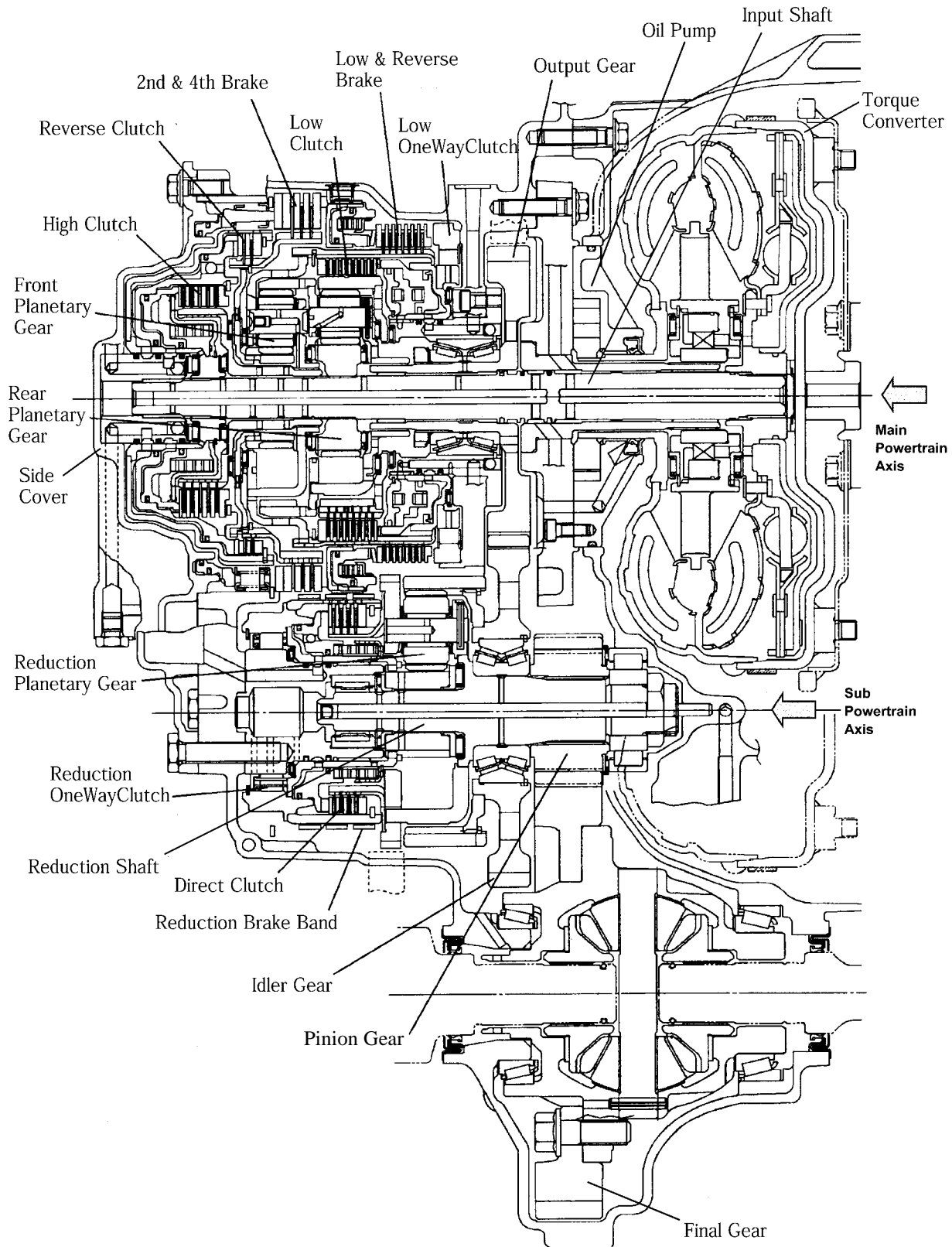

	O. D. Switch	Gear Position		Engine braking effect	Low clutch	2-4 brake	High clutch	Reverse clutch	Low and reverse brake	Reduction brake	Direct clutch	Low one-way clutch	Reduction one-way clutch	
P		-		-					O					
R	-	Reverse		Yes			O	O	O					
			Reverse Inhibition Control	No			O		O					
N	-	-		-					O					
D	O/D OFF Switch OFF	First		No	O							●	●	
		Second		No	O	O							●	
		Third		No	O		O						●	
		Fourth		No		O	O							●
		Fifth		Yes		O	O				O			
	O/D OFF Switch ON	Fifth		No	O								●	●
		Fifth		No	O	O								●
		Fifth		No	O		O							●
		Fifth*		Yes		O	O		O					
3	-			No	O	O								
				Yes	O		O		O				●	
			Fourth*	Yes		O	O			O				
			Fifth*	Yes		O	O				O			
2				Yes	O	O			O					
			Third*	Yes	O		O			O				
			Fourth*	Yes		O	O				O			
			Fifth*	Yes		O	O				O			

O : Operating

● : Transmits the torque only when driving

* : To prevent engine overspeed, inhibits downshift until the engine speed is reduced to the preset speed

Component description

Note: • All rotation are viewed from the side cover.

Component	Function
Low clutch	<ul style="list-style-type: none"> Transmits rotation of low clutch drum to rear internal gear Operates in 1GR, 2GR, and 3GR position
2-4 brake	<ul style="list-style-type: none"> Prevents rotation of front sun gear Operates in 2GR, 4GR, and 5GR position
High clutch	<ul style="list-style-type: none"> Transmits rotation of high clutch drum to front planetary carrier Operates in 3GR, 4GR, and 5Gr position
Reverse clutch	<ul style="list-style-type: none"> Transmits rotation of reverse clutch drum to front sun gear Operates when vehicle is reversing
Reduction brake	<ul style="list-style-type: none"> Prevents rotation of direct clutch drum and prevents rottion of reduction sun gear
Low and reverse brake	<ul style="list-style-type: none"> Prevents rotation of low clutch drum and front planetary carrier
Direct clutch	<ul style="list-style-type: none"> Transmits rotation of reduction planetary carrier to reduction sun gear Operates in 5GR position
Low one-way clutch	<ul style="list-style-type: none"> Locks clockwise rotation of front planetary carrier
Reduction one-way clutch	<ul style="list-style-type: none"> Locks counterclockwise rotation of reduction sun gear

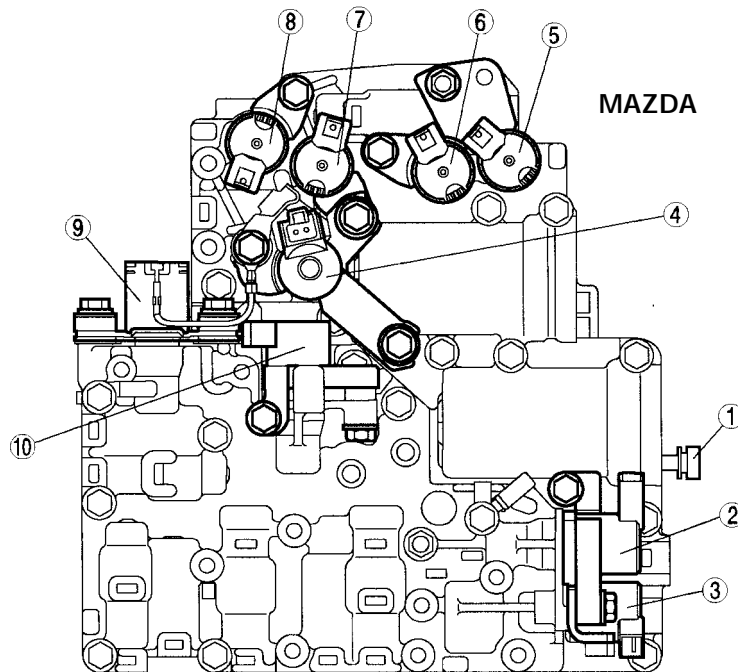
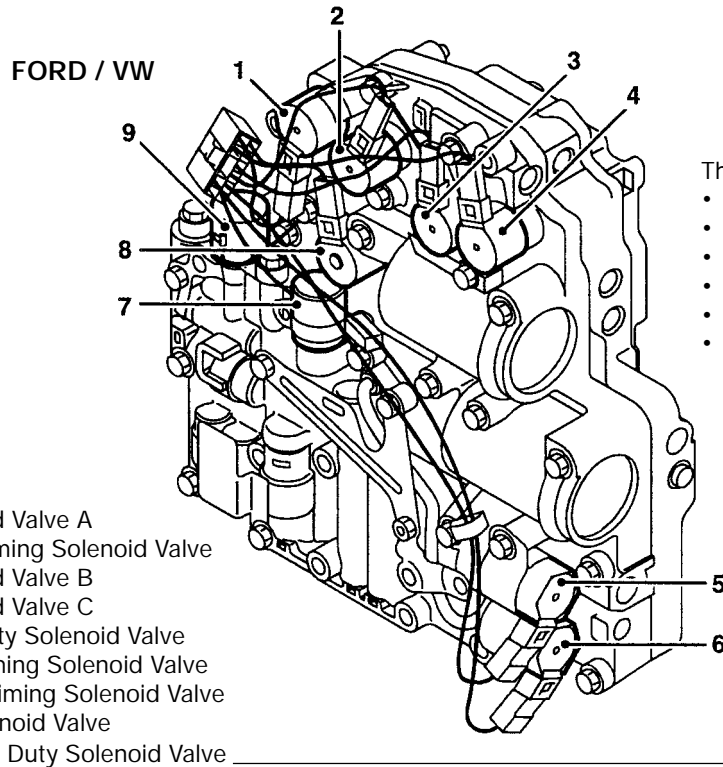

1	Manual valve
2	2-4 Brake Solenoid Valve
3	Neutral Shift Solenoid Valve
4	TCC Solenoid Valve
5	Shift Solenoid C

6	Shift Solenoid B
7	Reduction Timing Solenoid Valve
8	Shift Solenoid A
9	Pressure Control Solenoid
10	High Clutch Solenoid Valve

FORD/VW Shift Solenoid Sequence

Shift Solenoid Valve	Shift Solenoid Sequence				
	1st	2nd	3rd	4th	5th
A	X	O	X	X	O
B	O	O	O	X	X
C	O	X	X	O	O
X = Solenoid Valve Off; O - Solenoid Valve On					

The reduction timing solenoid valve, low clutch timing solenoid valve and 2-4 timing solenoid valve are utilised by the EAT ECU to control the timing of the gear shift changes. These solenoid valves carry out four main functions:

- Shift timing control: For some shifts these three solenoid valves are used to assist line pressure control or 2-4 brake pressure control.
- Line pressure cut back: When the gearbox takes up the drive, there should be a high line pressure present. The EAT ECU controls the low clutch timing solenoid valve which is related to the vehicle speed in order to switch the fluid circuit of the line pressure to on or off therefore controlling cut back.
- Reverse inhibition: If the vehicle exceeds 6 mph (10 km/h) and Reverse (R) is selected, the EAT ECU switches the low clutch timing solenoid valve on. This drains the gearbox fluid from the reverse clutch, therefore the clutch will be unable to engage.
- Idle neutral: The EAT ECU uses the low clutch timing and reduction timing solenoid valves to engage idle neutral.

Mode	O. D. Switch	MAZDA Gear Position		Solenoid Valve				
				Shift Solenoid A	Shift Solenoid B	Shift Solenoid C	Reduction Timing Solenoid	Neutral Shift Solenoid
P				O	O	O		
R	-	Reverse		O	O	O		
		Reverse inhibition control		O	O	O		O
N	-	-		O	O	O		
D	O/D OFF Switch OFF	First		O	O	O	O	
		Second		O	O		O	
		Third			O		O	
		Fourth				O	O	
		Fifth		O		O	O	
	O/D OFF Switch ON	Fifth		O	O	O	O	
		Fifth		O	O		O	
		Fifth			O		O	
		Fifth*		O		O	O	
3	-				O	O		O
		Fourth*				O		
		Fifth*		O		O	O	
2					O	O		
		Third*			O			
		Fourth*				O		
		Fifth*		O		O	O	

ATF Temperature: 20 °C (68 °F)

Solenoid Valve	Resistance (ohm)
2-4 Brake Solenoid Valve	2.6-3.2
TCC Solenoid Valve	12.0-13.2
High Clutch Solenoid Valve	2.6-3.2
Pressure Control Solenoid	2.6-3.2
Reduction Timing Solenoid Valve	14-18
Shift Solenoid C	14-18
Shift Solenoid B	14-18
Neutral Shift Solenoid Valve	14-18
Shift Solenoid A	14-18

**Output Speed Sensor
Intermediate Shaft Sensor
Input Speed Sensor**

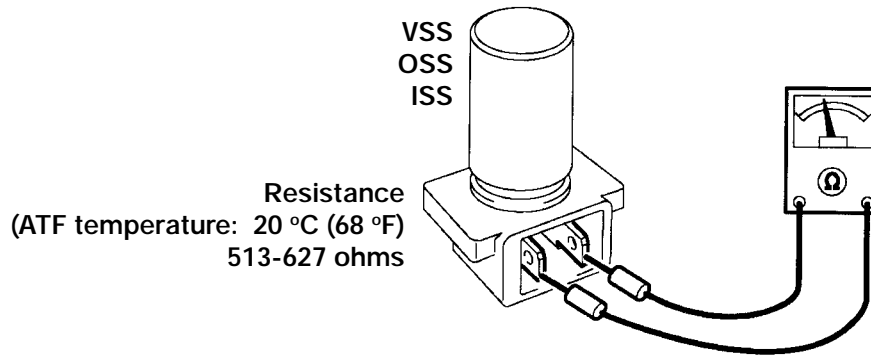

Fluid Temperature Sensor Resistance Values

Temperature, °C (°F)	Resistance, kΩ
-40 (-40)	54.90
-20 (-4)	16.70
0 (32)	6.02
20 (68)	2.50
40 (104)	1.16
60 (140)	0.59
80 (176)	0.33
100 (212)	0.19
120 (248)	0.12
140 (284)	0.08

Fluid Temperature Sensor

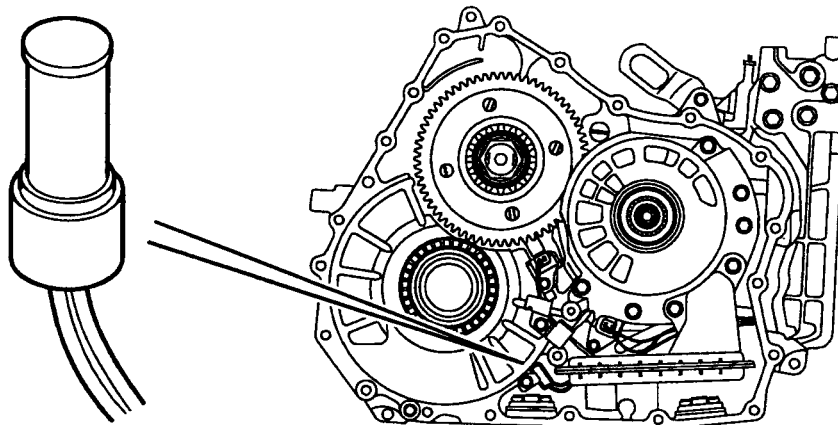

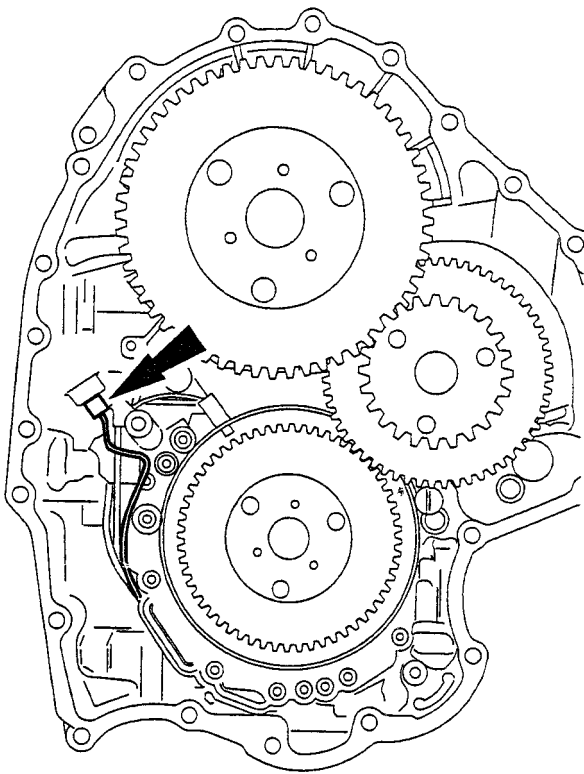

TOT Sensor

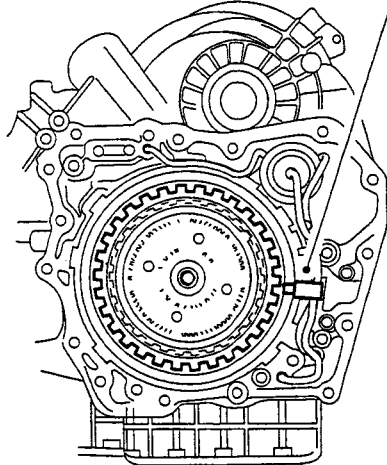
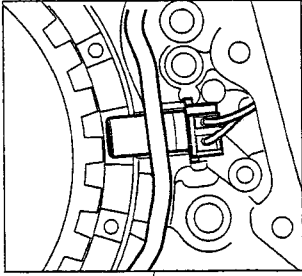

Input (Turbine)
Speed Sensor

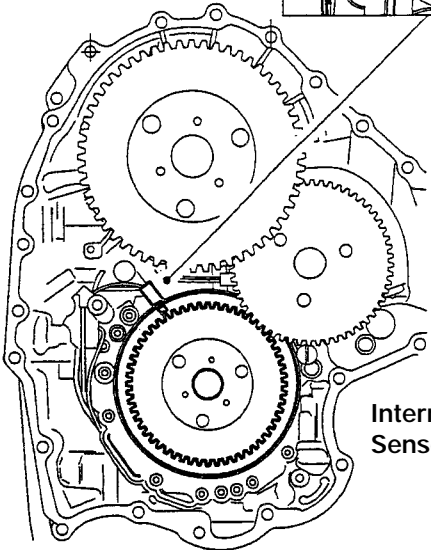
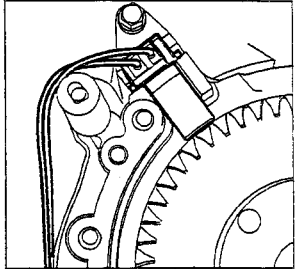

Intermediate Speed
Sensor

D, 3, 2 Ranges

Position/ Range	Line Pressure (kPa(psi))
	Idle
D, 3	290-490 (42-71)
2, R	550-750 (80-109)

Note: Not all pressure taps are the same or in the same location on all models.

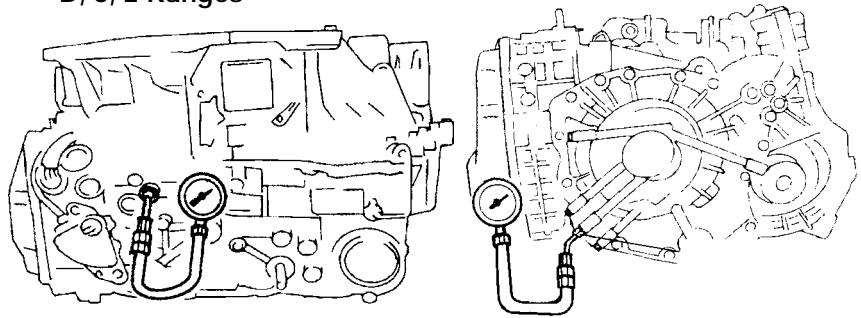

Evaluation of Line Pressure Test

Condition		Possible Cause
Idle	Below Specification	Worn oil pump Poor operation of each solenoid Fluid leaking from oil strainer, oil pump, pressure regulator valve, torque converter relief valve, and/or pressure relief valve Pressure regulator valve or pilot valve sticking Damaged pressure regulator valve spring or pilot valve spring
	Low pressure in D range only	Fluid leaking from hydraulic circuit of low clutch
	Low pressure in 3 and 2 ranges only	Fluid leaking from hydraulic circuit of low clutch and 2-4 brake
	Low pressure in R position only	Fluid leaking from hydraulic circuit of reverse clutch Fluid leaking from hydraulic circuit of low and reverse brake clutch

Fluid Level Check

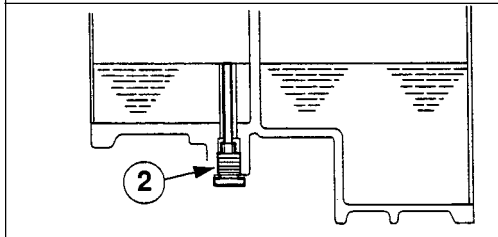
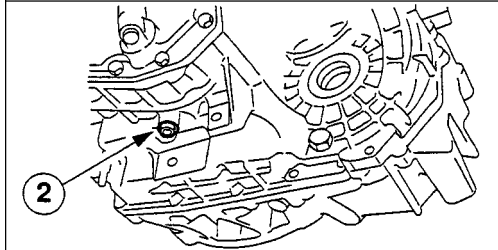
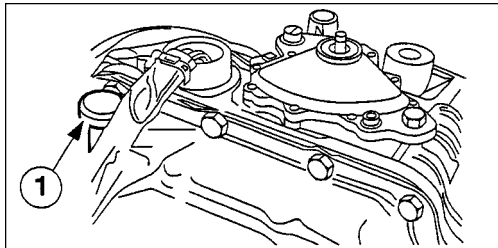

Throttle position sensor out of adjustment TFT sensor malfunction Poor operation of shift solenoid Pilot valve sticking Pressure reducing valve or plug sticking
Throttle position sensor out of adjustment Pressure control solenoid malfunction Poor operation of shift solenoid Pilot valve sticking Pressure reducing valve or plug sticking

- Once the temperature has reached 35°C/95°F remove the fluid level check plug. #2
- If transmission fluid flows out from the opening, wait until the flow stops.
- If no transmission fluid flows out, top up with transmission fluid through the filler neck #1 until fluid starts to escape from the level check plug opening.
- Install the fluid level check plug.

1	Oil Filler Neck
2	Fluid Level Check Plug