

Published: 18-Mar-2014

Handles, Locks, Latches and Entry Systems - Locks, Latches and Entry Systems

Diagnosis and Testing

Principle of Operation

For a detailed description of the locks, latches and entry systems and operation, refer to the relevant Description and Operation section of the workshop manual. REFER to: [Handles, Locks, Latches and Entry Systems](#) (501-14 Handles, Locks, Latches and Entry Systems, Description and Operation).

Inspection and Verification



CAUTION: Diagnosis by substitution from a donor vehicle is **NOT** acceptable. Substitution of control modules does not guarantee confirmation of a fault and may also cause additional faults in the vehicle being checked and/or the donor vehicle



NOTE: Check and rectify basic faults before beginning diagnostic routines involving pinpoint tests

1. Verify the customer concern, to be sure the correct issue is investigated
2. Visually inspect for obvious signs of damage and system integrity

Visual Inspection

Mechanical	Electrical
<ul style="list-style-type: none"> • Incorrectly aligned door(s), hood or tailgate • Fuel filler door lock actuator • Hood release handle • Hood release cables • Hood latch(es) • Exterior door handle(s) • Interior door handle(s) • Cable(s) • Tailgate release switch • Rear window release switch 	<ul style="list-style-type: none"> • Fuses • Wiring harness • Wiring connector(s) • Door lock actuator(s) • Remote transmitter (key-fob or smart key) • Central locking switches • Controller Area Network (CAN) circuits • Radio frequency (RF) receiver • Central junction box (CJB) • Loose or corroded connections

3. If an obvious cause for an observed or reported concern is found, correct the cause (if possible) before proceeding to the next step

4. If the cause is not visually evident verify the symptom and refer to the Symptom Chart, alternatively check for Diagnostic Trouble Codes (DTCs) and refer to the DTC Index

Symptom Chart



NOTE: Complete the diagnostic steps below to confirm any concern prior to replacing any component

Symptom	Possible Causes	Action
The message center indicates that the hood, the luggage compartment is open when it appears to be closed Vehicle indicates a miss-lock when the hood, luggage compartment appear to be closed	<ul style="list-style-type: none"> • Incorrect striker alignment/adjustment • Ajar switch circuit short circuit to ground • Ajar switch failure 	<ul style="list-style-type: none"> • Check/adjust the strikers as necessary • Check for DTCs indicating an ajar switch fault. Refer to the DTC index
Fuel flap does not lock/unlock	<ul style="list-style-type: none"> • Fuel flap cable detached from body • Fuel flap actuator detached from mounting bracket • Fuel flap actuator disconnected • Fuel flap actuator failure 	<ul style="list-style-type: none"> • Check the condition and installation of the fuel flap cable • Check the security of the fuel flap actuator and bracket • Check the security of the actuator electrical connector • Check for DTCs indicating a fuel flap actuator fault. Refer to the DTC index
Door(s) will not unlatch/open when using outside door handle		

Symptom	Possible Causes	Action
	<ul style="list-style-type: none"> Exterior door handle condition/installation Exterior release cable disconnected from exterior door handle or door latch 	<ul style="list-style-type: none"> Check the exterior door handle condition and installation Check the condition and security of the exterior release cable Single door will not open from the outside (but opens from the inside) GO to Pinpoint Test A.
Door(s) will not unlatch/open when using inside door handle	<ul style="list-style-type: none"> Child lock(s) engaged Interior door handle condition/installation Interior release cable disconnected from interior door handle or door latch 	<ul style="list-style-type: none"> Check that the child locks are disengaged Check the interior door handle condition and installation Check the condition and security of the interior release cable Single Door Will Not Open From The Inside (but opens from the outside) GO to Pinpoint Test B.
Door(s) will not lock/unlock from key fob, key or internal lock switch	<ul style="list-style-type: none"> Wiring harness/connectors Central junction box (CJB) Door lock switch Cable fault 	<ul style="list-style-type: none"> Check for relevant stored DTCs Once any DTC related faults have been rectified continue with the diagnostic steps below No lock / unlock function from key-fob GO to Pinpoint Test C.
Door ajar or miss lock signal at message centre when door(s) are closed or alarm triggering	<ul style="list-style-type: none"> Wiring harness Instrument cluster Incorrect striker alignment/adjustment Ajar switch circuit short circuit to ground Ajar switch failure 	<ul style="list-style-type: none"> Latch Mounted Door Ajar Switch Test GO to Pinpoint Test D.

DTC Index

For a list of Diagnostic Trouble Codes (DTCs) that could be logged on this vehicle, please refer to Section 100-00. REFER to: [Communications Network](#) (418-00 Module Communications Network, Diagnosis and Testing) / [Locks, Latches and Entry Systems](#) (501-14 Handles, Locks, Latches and Entry Systems, Diagnosis and Testing).

Pinpoint Test

PINPOINT TEST A : SINGLE DOOR WILL NOT OPEN FROM THE OUTSIDE (BUT OPENS FROM THE INSIDE)	
TEST CONDITIONS	DETAILS/RESULTS/ACTIONS
A1: CHECK THE EXTERIOR DOOR RELEASE CABLE TO EXTERIOR DOOR HANDLE IS INSTALLED CORRECTLY	
	<ol style="list-style-type: none"> Remove the door trim panel as necessary

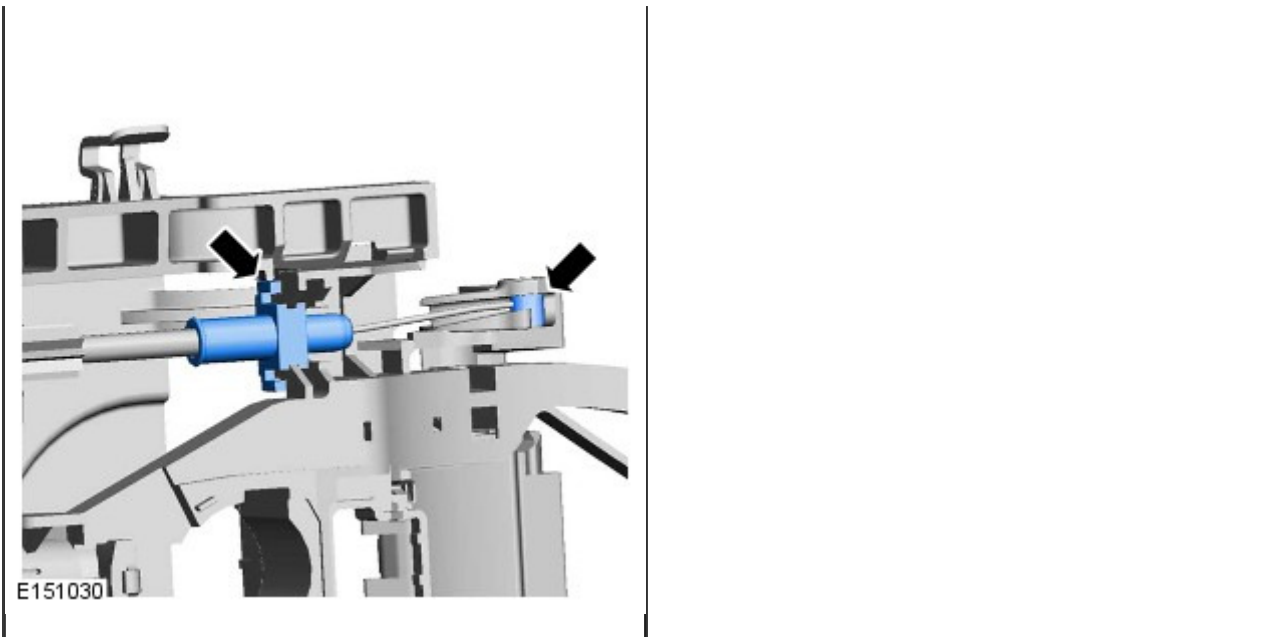

2 Confirm the exterior door release cable is correctly installed to the exterior door handle

Is the cable correctly installed?
Yes
[GO to A2.](#)
No
 Connect the door release cable correctly. **If the cable is damaged, install a new door release cable.** Test the system for normal operation

A2: CHECK THE EXTERIOR DOOR HANDLE RELEASE CONNECTION TO THE DOOR LATCH

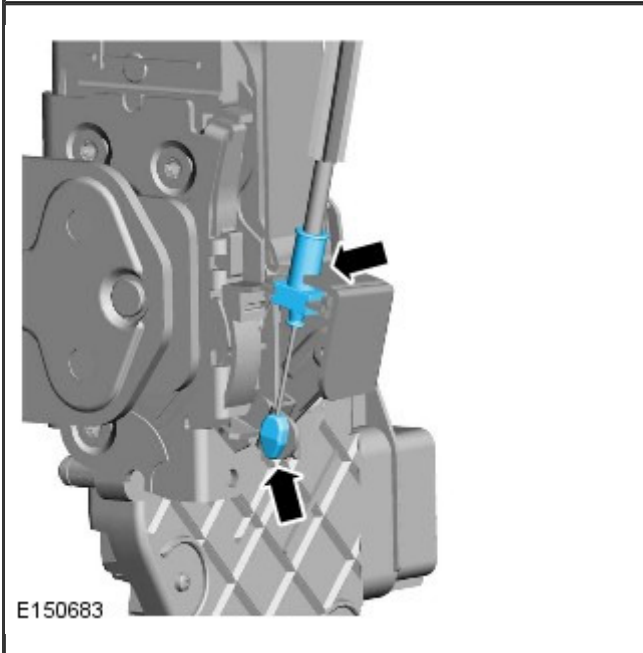

1 Confirm the exterior door handle release connection to the door latch is installed correctly

Is the exterior door handle release cable installed correctly?
Yes
 GO to Pinpoint Test [C.](#)
No
 Connect the door release cable correctly. **If the cable is damaged, install a new door release cable.** Test the system for normal operation

PINPOINT TEST B : SINGLE DOOR WILL NOT OPEN FROM THE INSIDE (BUT OPENS FROM THE OUTSIDE)

TEST CONDITIONS	DETAILS/RESULTS/ACTIONS

B1: CHECK THE INTERIOR DOOR RELEASE CABLE TO INTERIOR DOOR HANDLE IS INSTALLED CORRECTLY

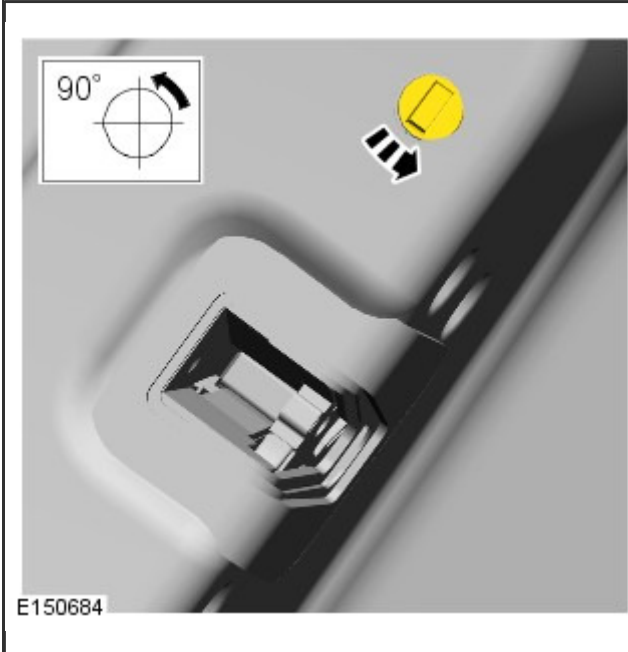

NOTE: Figure A - Child lock off position shown

- 1** Make sure the child lock is disengaged (rear door only)

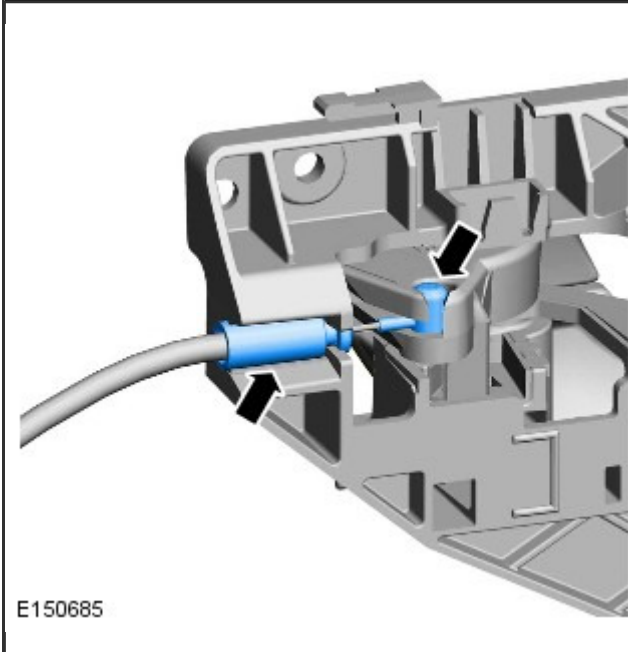

- 2** Remove the door trim panel as necessary

- 3** Confirm the interior door release cable is correctly installed to the interior door handle

Is the cable correctly installed?

Yes
[GO to B2.](#)

No
 Connect the door release cable correctly. **If the cable is damaged, install a new door release cable.** Test the system for normal operation

B2: CHECK THE INTERIOR DOOR HANDLE RELEASE CONNECTION TO THE DOOR LATCH

- 1** Confirm the interior door handle release connection to the door latch is installed correctly

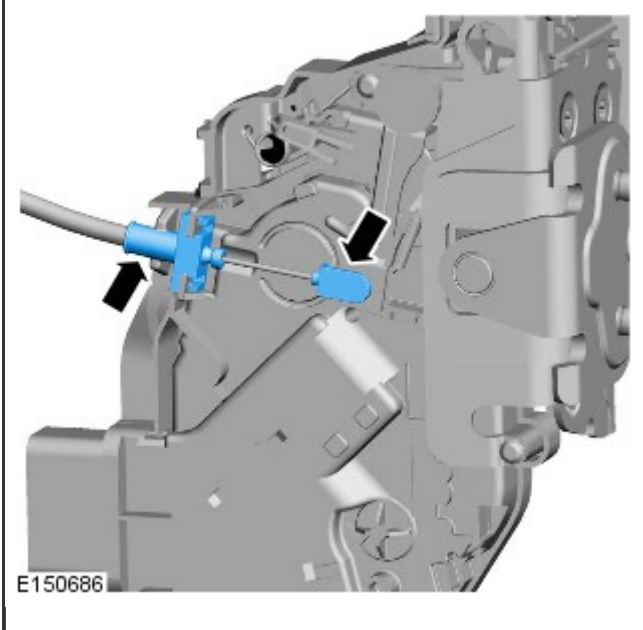

E150686

Is the interior door handle release cable installed correctly?
Yes
 GO to Pinpoint Test [C.](#)
No
 Connect the door release cable correctly. **If the cable is damaged, install a new door release cable.** Test the system for normal operation

PINPOINT TEST C : DOOR LATCHING AND LOCKING FUNCTION TEST

TEST CONDITIONS	DETAILS/RESULTS/ACTIONS
-----------------	-------------------------

C1: HARNESS CONNECTION

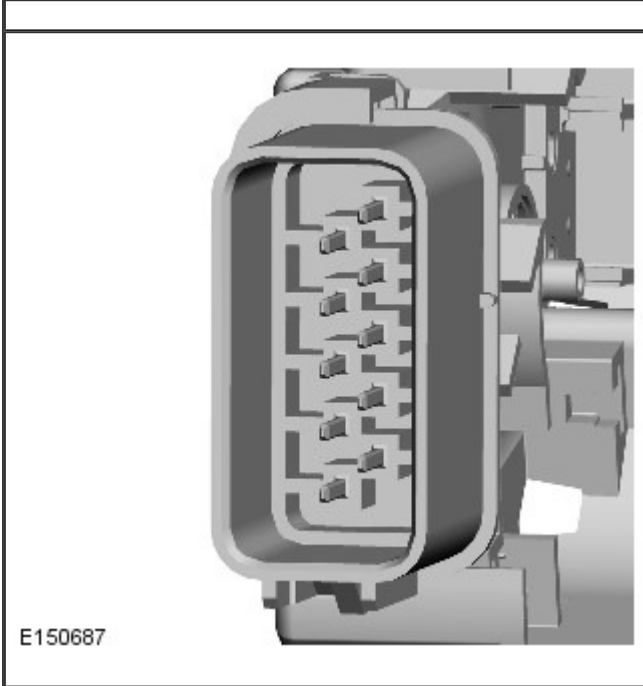

 **NOTE:** Test as a single component to ensure that the door latch is not replaced unnecessarily, when another component may be at fault



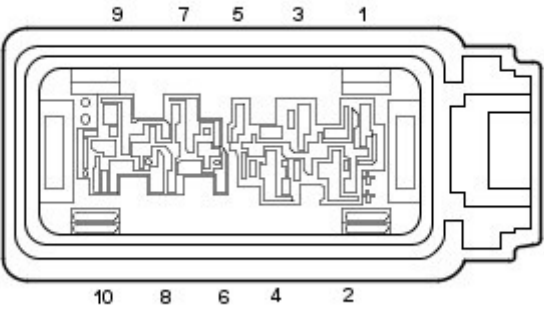

E150687

- 1** Remove the door trim panel as necessary
- 2** Disconnect harness from latch, check for corrosion or damage to both connectors at socket points and pins. Re-connect harness ensuring robust assembly when all parts confirmed to be in good order. If harness or latch connectors are damaged, install new harness/latch as necessary. Test the system for normal operation

Check for normal operation, does latch function correctly?
Yes
 Re-assemble door trim and test for normal operation
No

GO to C2.	
C2: LOCK COMMAND SIGNAL FROM VEHICLE HARNESS	
 <p>E139357</p>	<p>1 Close all vehicle doors apart from door being investigated, please note which door, left side or right side is under investigation</p>
	<p>2 Disconnect harness from latch to enable access to socket points to carry-out conductivity testing as detailed</p>
	<p>3 Monitor the circuit for momentary power when locking the vehicle via the key-fob or smart key between terminals 5 and 7 left side or 5 and 7 right side</p>
	<p>Is there momentary power (for approx 8 seconds) between terminals 5 and 7 left side or 5 and 7 right side when locking the vehicle via the key-fob or smart key</p> <p>Yes The vehicle electrical system is locking correctly, providing the signal to the latch GO to C3.</p> <p>No Refer to the electrical circuit diagrams and investigate why vehicle electrical system is not providing signals to the latch. Using the manufacturer approved diagnostic system check for logged DTCs to localize the fault</p>
C3: UNLOCK COMMAND SIGNAL FROM VEHICLE HARNESS	
	<p>1 Monitor the circuit for momentary power when unlocking the vehicle via the key-fob or smart key between terminals 5 and 7 left side or 5 and 7 right side</p>
	<p>Is there momentary power (for approx 8 seconds) between terminals 5 and 7 left side and 5 and 7 right side when unlocking the vehicle via the key-fob or smart key?</p> <p>Yes The vehicle electrical system is unlocking correctly, providing the signal to the latch GO to C4.</p> <p>No Refer to the electrical circuit diagrams and investigate why vehicle electrical system is not providing signals to the latch. Using the manufacturer approved diagnostic system check for logged DTCs to localize the fault</p>
C4: PHYSICAL TEST 1	
	<p>1 Remove latch module from door</p>
	<p>2 Inspect latch module for any visual damage</p>
	<p>3 With the latch in hand, connect the electrical connector(s) to connect door latch to door harness</p>
	<p> NOTE: THE LATCH IS NOW READY TO TEST</p>
	<p>4 Close all vehicle doors except the door being investigated</p>
	<p>NOTES:</p> <p> Figure 1 - Unlatched position shown</p>

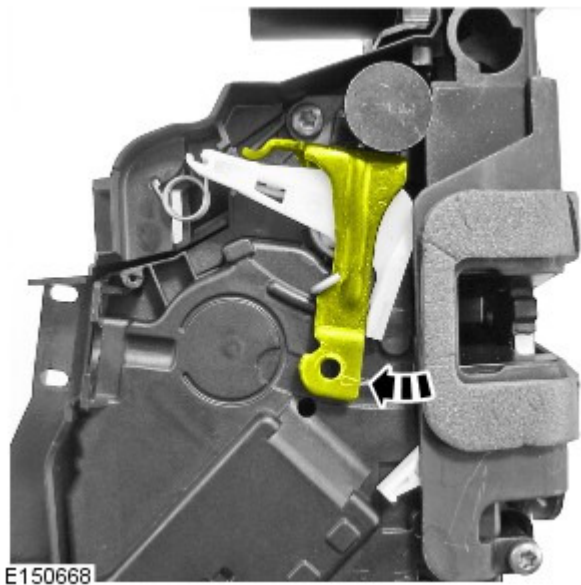
<p>①</p> 	<p>△ Figure 2 - First safety latched position shown</p> <p>△ Figure 3 - Fully latched position shown</p> <p>△ Test will not work if latch is only in first safety latch position</p>
<p>②</p> 	<p>⑤ Rotate latch claw (using a small screw driver or similar), to the fully latched position (figure 3)</p>
<p>③</p>  <p>E139349</p>	
 <p>E150668</p>	<p>△ NOTE: Unlocked position shown</p> <p>⑥ Confirm that the latch interior release lever is in the unlocked position as shown</p>
	<p>△ NOTE: Locked position shown</p> <p>⑦ Press the lock button on the key-fob or smart key</p>

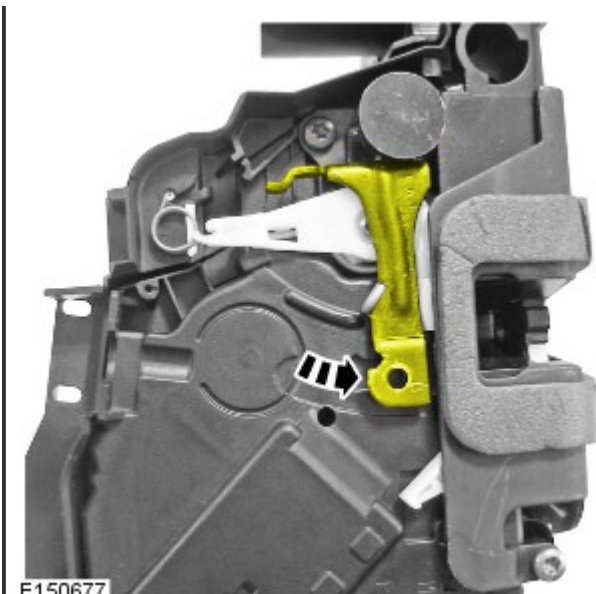

E150677

Does the latch interior release lever move from the unlocked position to the locked position?

Yes

[GO to C5.](#)

No

If this is a repeat test and the vehicle electrical test section has been completed and confirmed that vehicle is working correctly, then replace the door latch. If replacing latch as part of a warranty claim, please quote reference code **LKINOP** in the technician comments section of the warranty claim

C5: PHYSICAL TEST 2

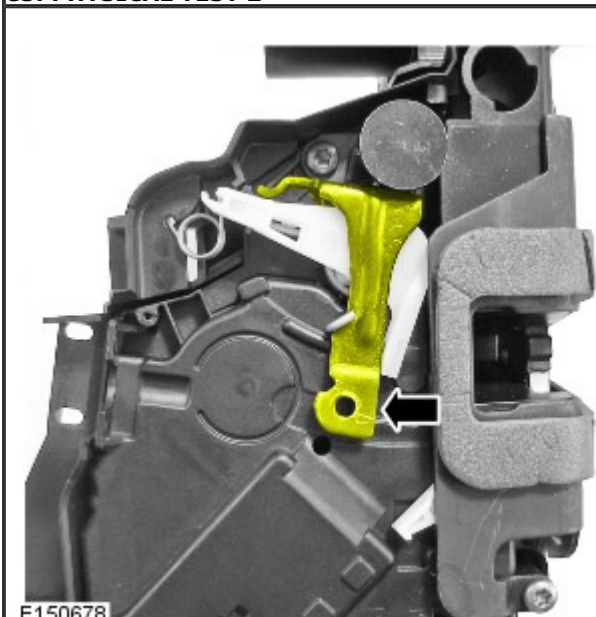

E150678

 **NOTE:** Unlocked position shown

1 With the latch in the locked state (i.e. the latch interior release lever is in the locked position), press the key-fob or smart key **unlock** button

Does the latch interior release lever move from the locked position to the unlocked position?

Yes

[GO to C6.](#)

No

If this is a repeat test and the vehicle electrical test section has been completed and confirmed that vehicle is working correctly, then replace the door latch. If replacing latch as part of a warranty claim, please quote reference code **LKINOP** in the technician comments section of the warranty claim

C6: PHYSICAL TEST 3

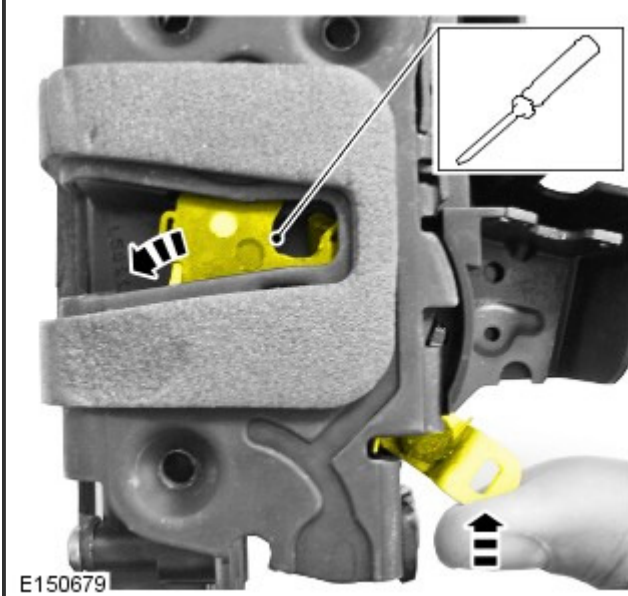

NOTE: Fully latched position shown

1 With the latch in its unlocked state, push the latch exterior release lever against its return spring, whilst simultaneously applying a light pressure to release the latch claw using a small screw driver or similar

Does the latch claw release?
Yes [GO to C7.](#)
No Repeat tests **C5** and **C6** to confirm the fault [GO to C5](#). If the repeat test has confirmed that the exterior release lever will not release the claw on an unlocked latch replace the door latch. If replacing latch as part of a warranty claim, please quote reference code **EXTINOP** in the technician comments section of the warranty claim

C7: PHYSICAL TEST 4



NOTE: Fully latched position shown

1 Using a small screw driver or similar, rotate latch claw to the second fully latched position

NOTE: Figure A - Child lock off position shown

2 If testing a rear door latch, ensure that the child lock is turned to the off position

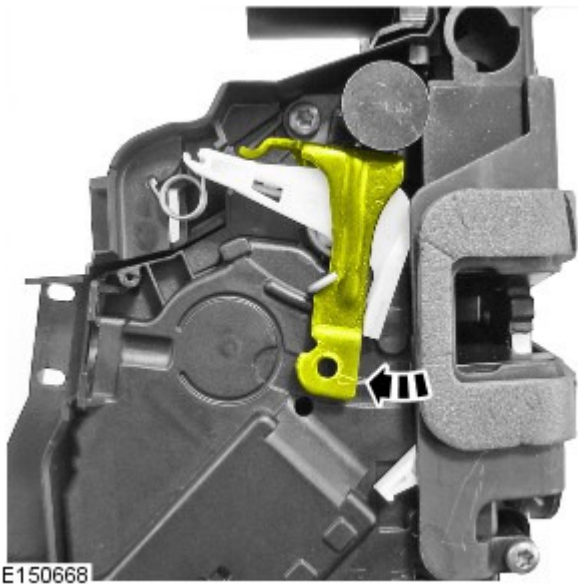
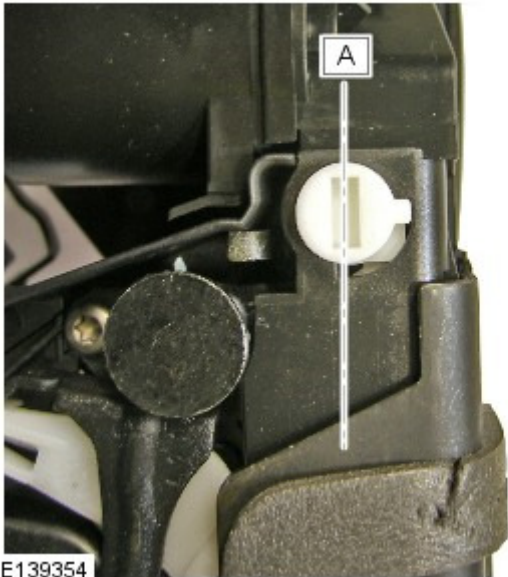

NOTE: Unlocked position shown

- 3** Confirm that the latch interior release lever is in the unlocked position as shown



- 4** Whilst the latch is still in its unlocked state, push the latch interior release lever against its return spring, whilst simultaneously applying a light pressure to release the latch claw using a small screw driver or similar

	<p>Does the latch claw release?</p> <p>Yes Latch has passed all tests to confirm its correct function. DO NOT REPLACE LATCH as part of any attempts to resolve any locking functionality issues</p> <p>No Repeat test GO to C7. If repeat test has confirmed that the interior release lever will not release the claw when the latch is in the unlocked state, then replace the latch. If replacing latch as part of a warranty claim, please quote reference code INTINOP in the technician comments section of the warranty claim</p>
--	--

PINPOINT TEST D : LATCH MOUNTED DOOR AJAR SWITCH TEST

TEST CONDITIONS	DETAILS/RESULTS/ACTIONS
-----------------	-------------------------

D1: TEST 4 DOOR LATCH







NOTES:

 If a customer is complaining of issues relating to a door ajar signal e.g. door latch won't lock, or alarm system triggering (indicated via DTC's), there may be several components that generate the fault, including

- Body wiring harness / connectors
- Door wiring harness / connectors
- Alarm control module
- Central junction box (CJB)
- Door Latch ajar switch

 To investigate the functioning of the door ajar switch contained within the door latch, to prove or eliminate the door latch mounted door ajar switch as the root cause, follow the process below. This will prevent the unnecessary replacement of a correctly functioning door latch

- 1** Remove door trim from door
- 2** Disconnect door harness from latch for access to connector pins for latch electrical testing
- 3** Inspect latch module for any visual damage

	<p>NOTES:</p> <p> Figure 1 - Unlatched position shown</p> <p> Figure 2 - First safety latched position shown</p> <p> Figure 3 - Fully latched position shown</p> <p> Test will not work if latch is only in first safety latch position</p>
	<p>4 Using a small screw driver or similar, rotate latch claw to the second fully latched position (figure 3)</p>
	

E139349

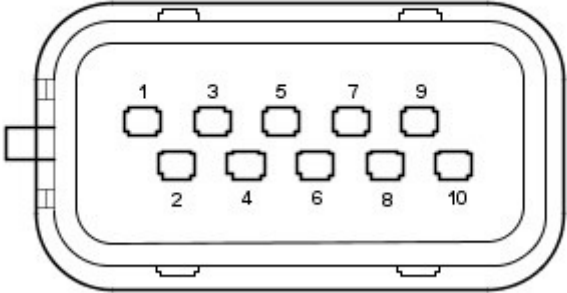
 <p>E139356</p>	<p>5 Carry out continuity test between terminals 1 and 4 (left side) or 8 and 4 (right side) with claw closed</p>
	<p>Does the continuity test pass?</p> <p>Yes The latch ajar switch is working correctly. Do not replace latch. Investigate for fault elsewhere in vehicle system</p> <p>No Release latch claw and repeat test from step 4 to confirm result. If this is a repeat test and you are sure that the ajar switch does not provide continuity when fully latched. Replace the latch. If replacing latch as part of a warranty claim, please quote reference code AJARINOP in the technician comments section of the warranty claim</p>