

2010.0 XF (X250), 303-01

ENGINE - V8 S/C 5.0L PETROL

VALVE COVER LH (G1193797)

REMOVAL AND INSTALLATION

12.29.43	CAMSHAFT COVER - LEFT HAND - RENEW	5000 CC, AJ V8, SUPERCHARGED	6.4	USED WITHINS
----------	--	------------------------------------	-----	-----------------

SPECIAL TOOL(S)

 E116982	303-1446 Valve Cover Alignment Tool
--	--

REMOVAL

 **NOTE:**

Removal steps in this procedure may contain installation details.

1. Refer to: [Battery Disconnect and Connect](#) (414-01 Battery, Mounting and Cables, General Procedures).
2. Refer to: [Supercharger](#) (303-12D Intake Air Distribution and Filtering - V8 S/C 5.0L Petrol, Removal and Installation).
3. Refer to: [Secondary Bulkhead Panel LH - TDV6 3.0L Diesel /V8 5.0L Petrol/V8 S/C 5.0L Petrol](#) (501-02 Front End Body Panels, Removal and Installation).
4. Refer to: [Air Cleaner Outlet Pipe LH](#) (303-12C Intake Air Distribution and Filtering - V8 5.0L Petrol, Removal and Installation).
5. Refer to: [Fuel Rail LH](#) (303-04D Fuel Charging and Controls - V8 S/C 5.0L Petrol, Removal and Installation).

6.

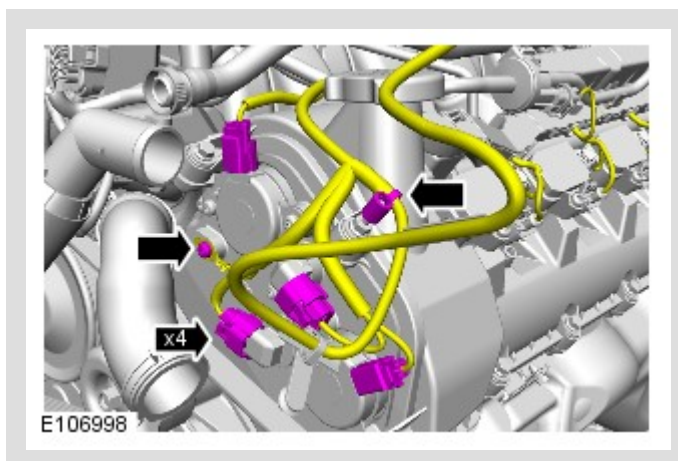

Torque: 10 Nm

7.

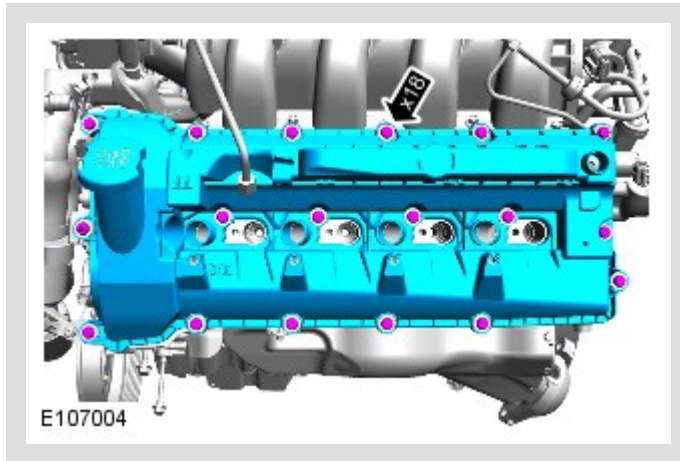

INSTALLATION

1.

⚠ CAUTIONS:

- Use only a plastic scraper when removing the sealing material.
- Use lint free cloth.
- Make sure that the mating faces are clean and free of corrosion and foreign material.
- Installation of the valve cover and tightening must be carried out within 7 minutes of applying the sealant.

 **NOTES:**

- Some variation in the illustrations may occur, but the essential information is always correct.
- Apply two beads of silicone gasket sealant (Loctite 5901) as shown on the illustration. The application of the sealant must be 1.5mm diameter 12mm long. Install the valve cover immediately after applying the sealant. The cover should be fitted directly to the head without smearing the sealant or the seals.

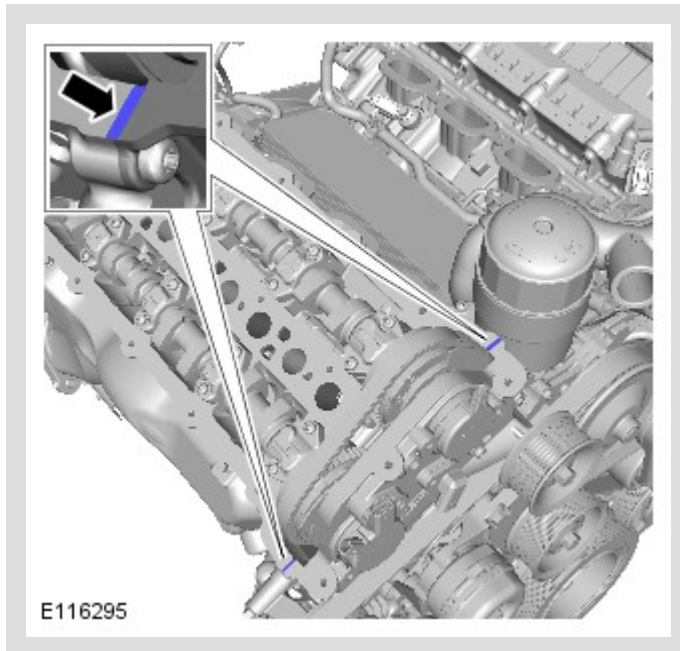

To install, reverse the removal procedure.

2.

 **NOTE:**

Some variation in the illustrations may occur, but the essential information is always correct.

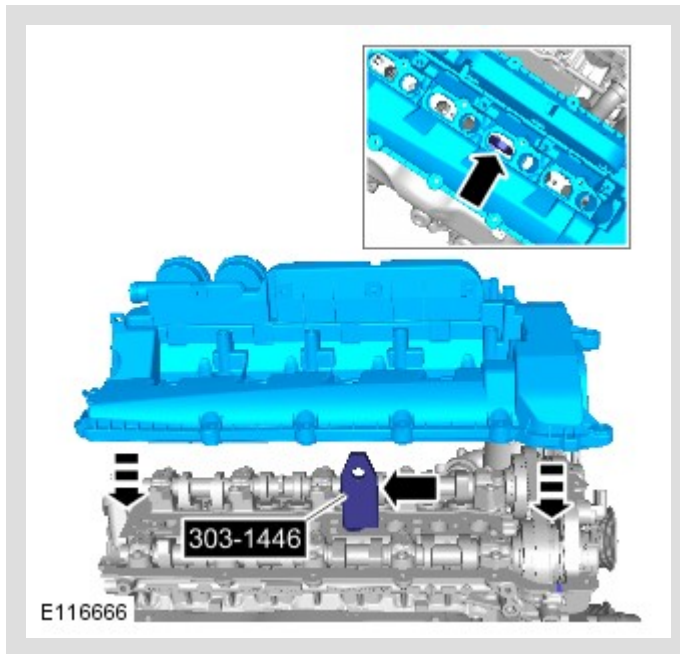

Special Tool(s): 303-1446

3.

 **NOTE:**

Tighten the bolts in the indicated sequence.

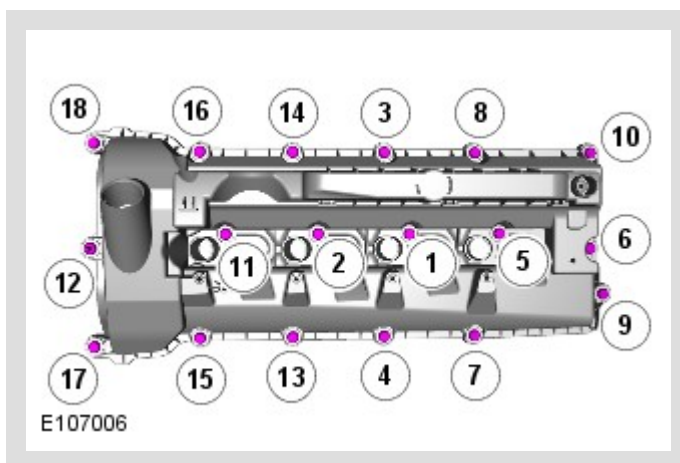

Torque: **13 Nm**

