

2010.0 XF (X250), 303-01

ENGINE - V8 S/C 5.0L PETROL

FUEL PUMP CAMSHAFT - ASSEMBLY PART NUMBER: TSUBAKI TIMING DRIVE (G1453729)

REMOVAL AND INSTALLATION

REMOVAL

NOTE:

Some illustrations may show the engine removed for clarity.

1. Refer to: [Battery Disconnect and Connect](#) (414-01 Battery, Mounting and Cables, General Procedures).

2. WARNING:

Make sure to support the vehicle with axle stands.

Raise and support the vehicle.

3. Refer to: [Oil Pan Extension](#) (303-01D Engine - V8 S/C 5.0L Petrol, Removal and Installation).

- 4.

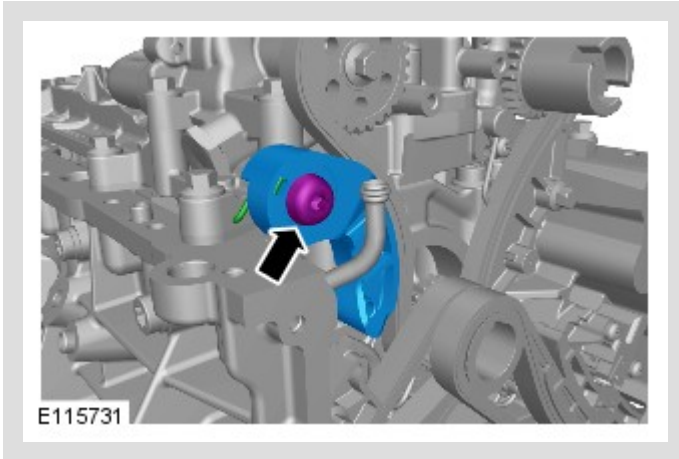

5.

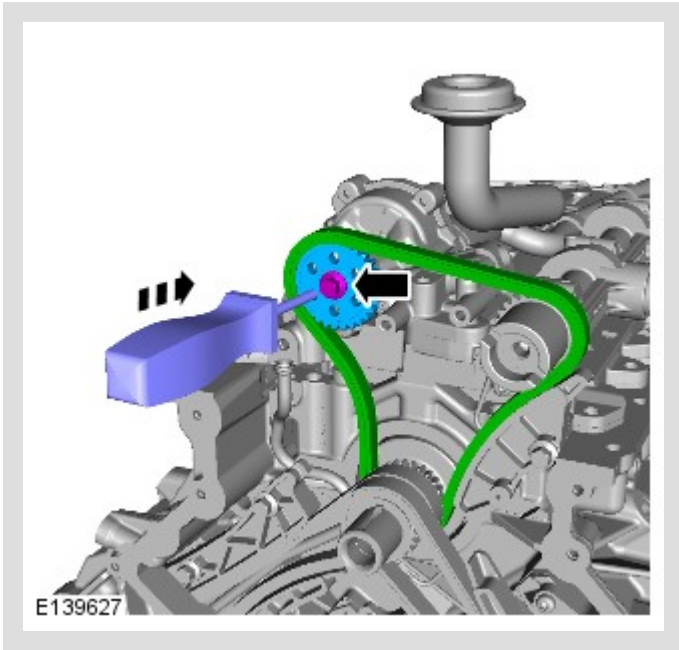

6.

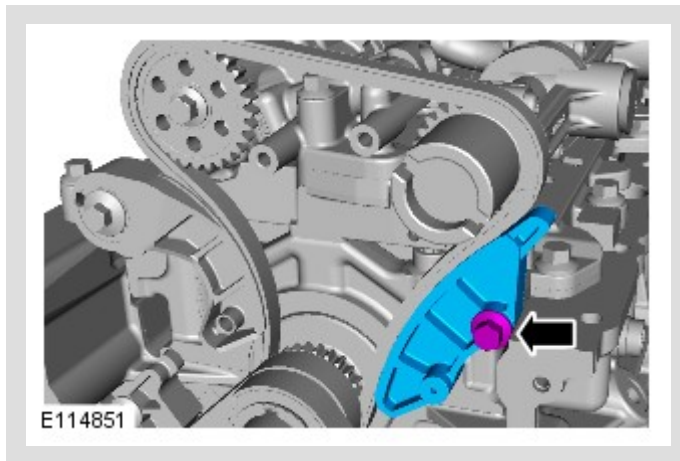

7.

⚠ CAUTION:

Take extra care when removing the component, prevent damage to the mating faces.

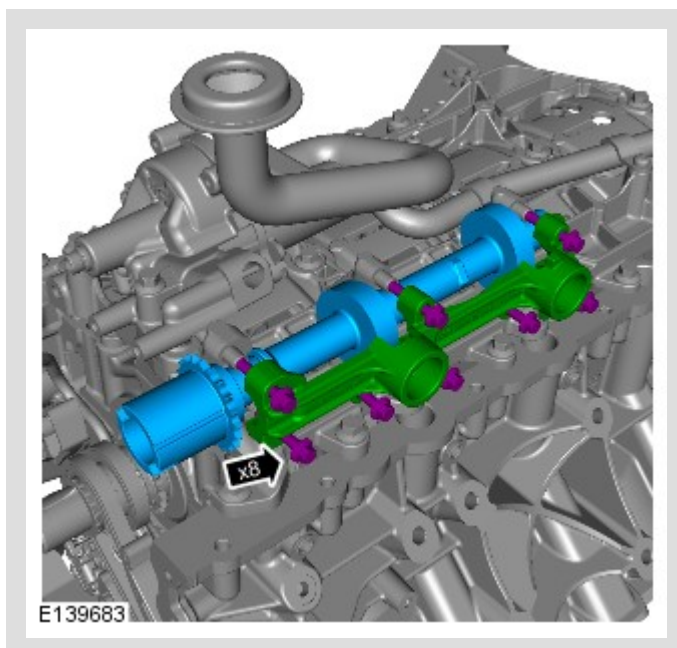

INSTALLATION

1.

⚠ CAUTION:

Make sure that the mating faces are clean and free of foreign material.

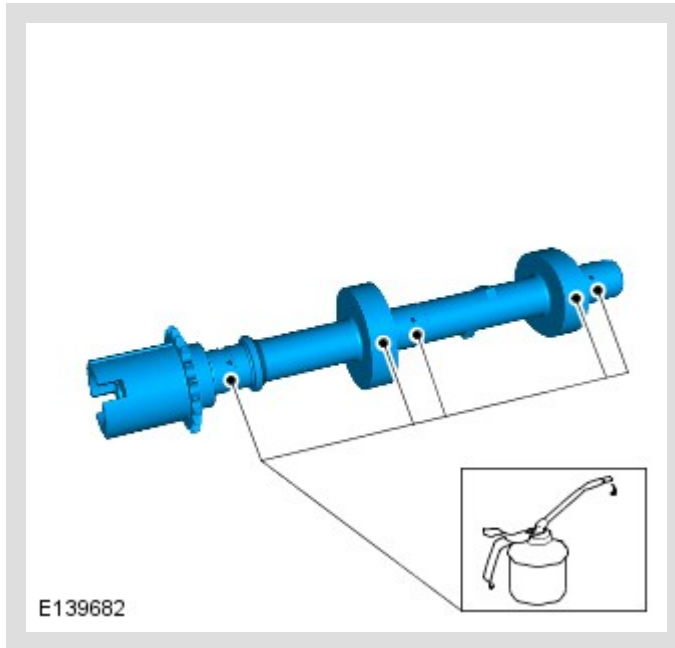

2.

⚠ CAUTION:

Take extra care not to damage the mating faces.

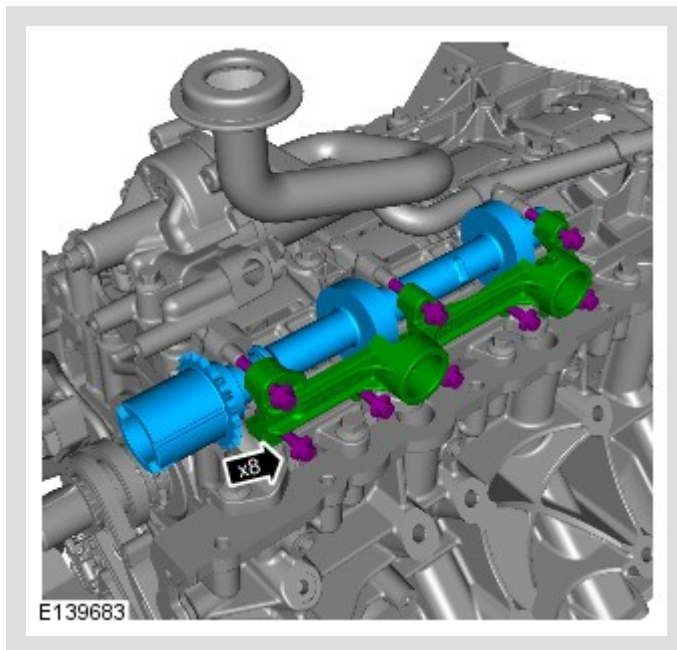

Torque: 12 Nm

3.

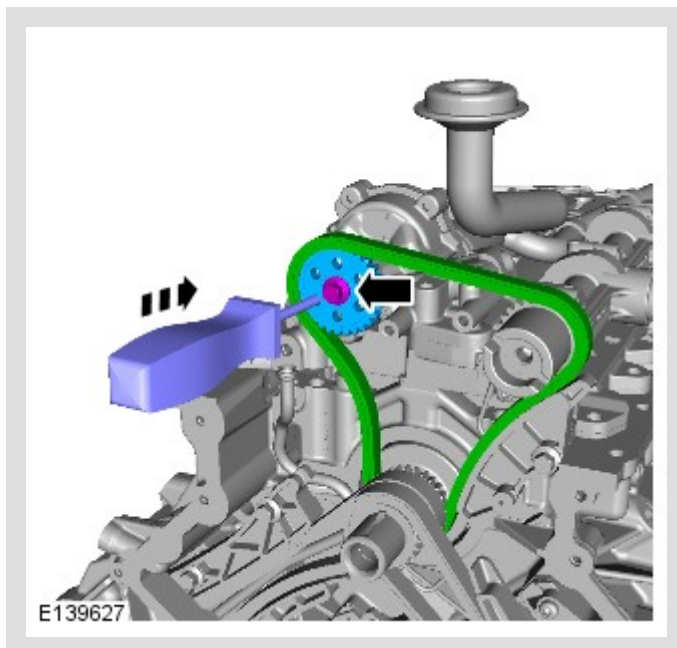

Torque: 21 Nm

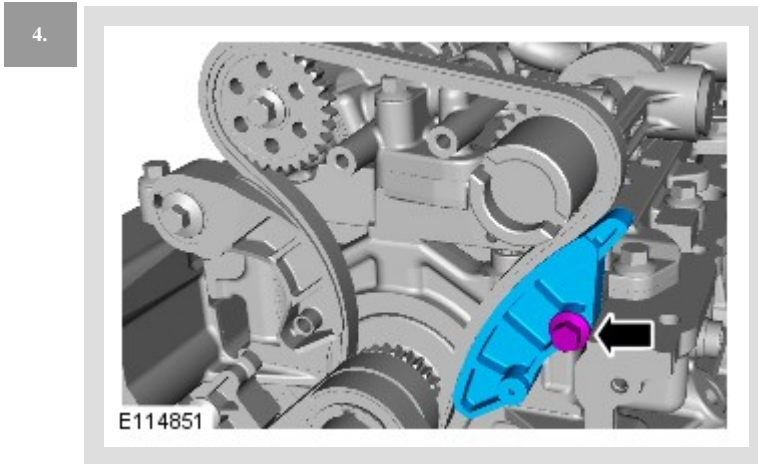

Torque: 12 Nm

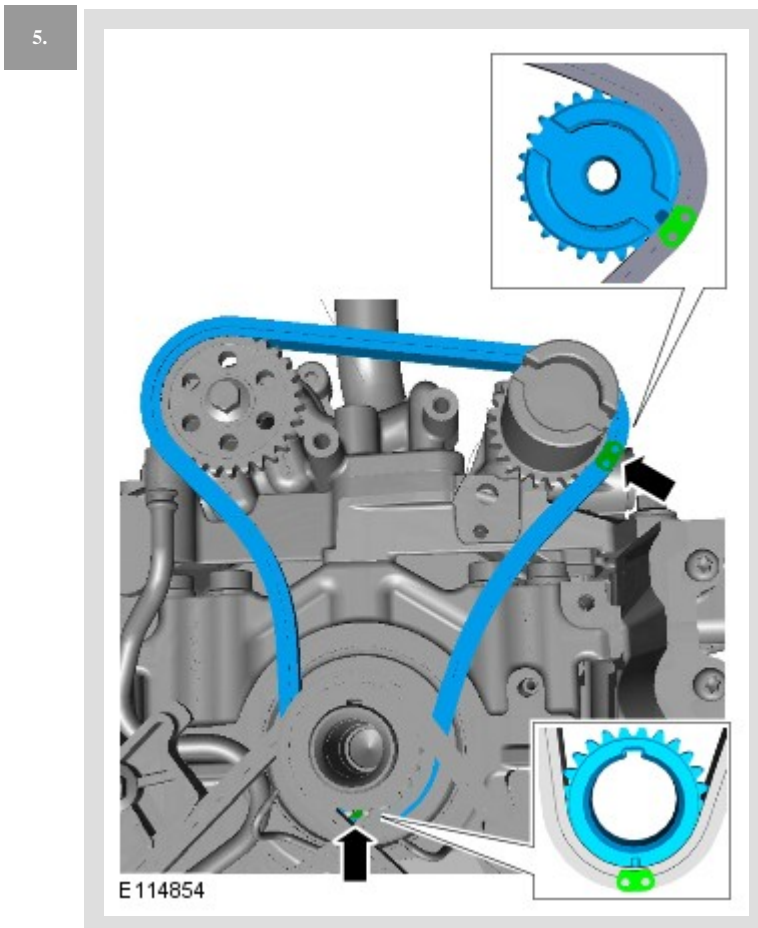

Install the lower timing chain making sure the coloured chain links align correctly with the fuel rail high-pressure fuel pumps camshaft and crankshaft sprocket markings.

6.

⚠ CAUTION:

Make sure that the tensioner spring is correctly located.

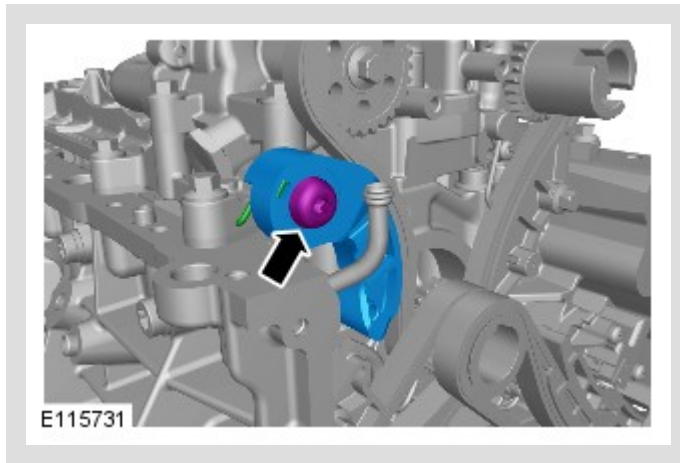

Torque: 21 Nm

7. Refer to: [Oil Pan Extension](#) (303-01D Engine - V8 S/C 5.0L Petrol, Removal and Installation).
8. Connect the battery ground cable.
Refer to: [Battery Disconnect and Connect](#) (414-01 Battery, Mounting and Cables, General Procedures).