

2010.0 XF (X250), 303-01

ENGINE - V8 S/C 5.0L PETROL

## ENGINE MOUNT LH (G1085671)

### REMOVAL AND INSTALLATION

12.45.01	ENGINE MOUNTING - LEFT HAND - RENEW	5000 CC, AJ V8	1.3	USED WITHINS	
----------	-------------------------------------	----------------	-----	--------------	--

### REMOVAL

#### NOTE:

Removal steps in this procedure may contain installation details.

All vehicles

1. Refer to: [Battery Disconnect and Connect](#) (414-01 Battery, Mounting and Cables, General Procedures).

#### 2. WARNING:

Do not work on or under a vehicle supported only by a jack. Always support the vehicle on safety stands.

Raise and support the vehicle.

3.

Refer to: [Air Conditioning \(A/C\) Compressor - V8 5.0L Petrol /V8 S/C 5.0L Petrol](#) (412-03 Air Conditioning, Removal and Installation).

4.

**⚠ CAUTION:**

Support the engine on a jack. The angle may need to be adjusted during this procedure.

Support the engine with the lifting equipment.

Left-hand drive vehicles

1.

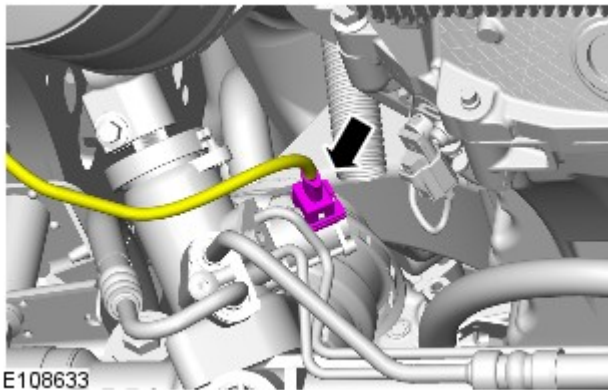

2.

**△ NOTE:**

Note the fitted position.

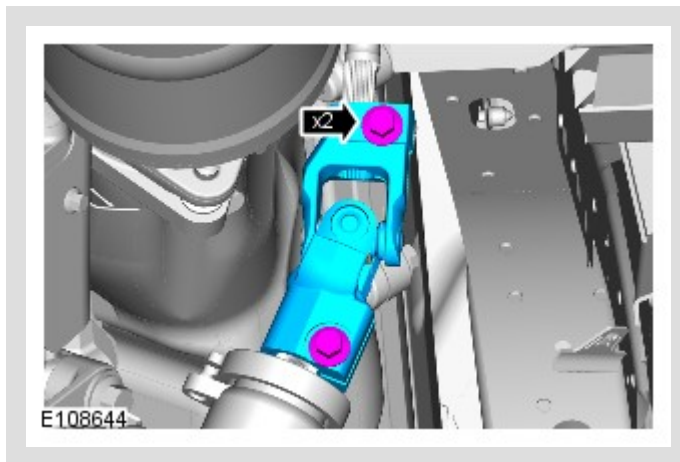

- *Torque: 35 Nm*
- Right-hand side shown, left-hand side similar.

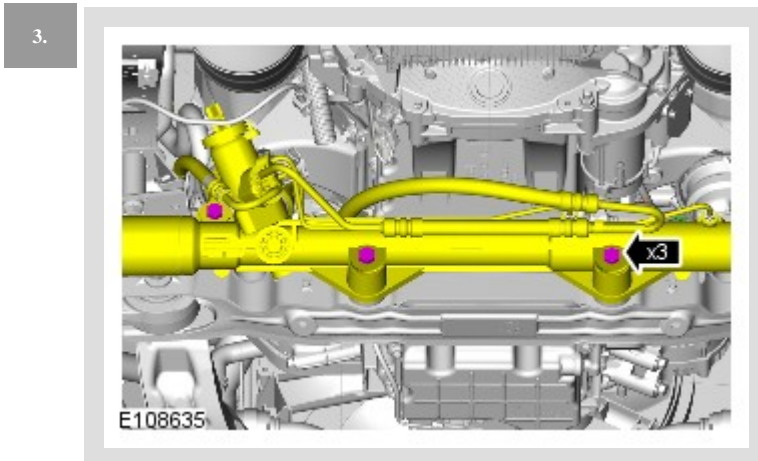

- *Torque: 100 Nm*
- Support and release the power steering rack.

All vehicles

1.

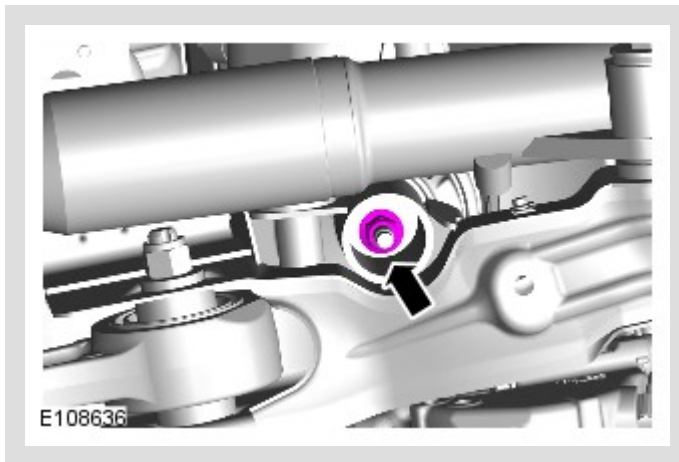

- **Torque: 63 Nm**
- Remove and discard the nut.

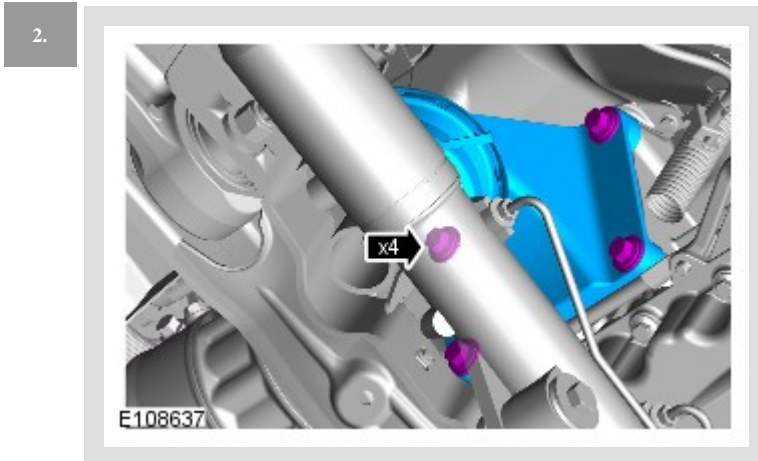

- **Torque: 48 Nm**
- Raise the engine.

3.  **NOTE:**

Do not disassemble further if the component is removed for access only.

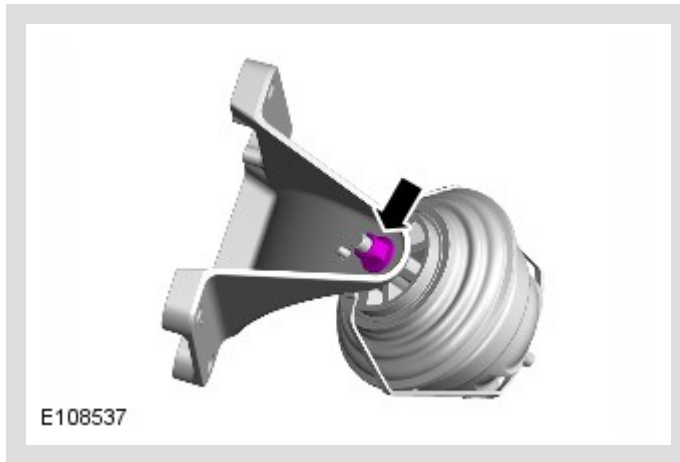

- *Torque: 48 Nm*
- Remove and discard the nut.

## INSTALLATION

1. To install, reverse the removal procedure.