

Wiring diagrams for front seats from X351(XJ) and X250(XF)



Original seat from my 2011 XF (top picture) has no control modules attached under seat. The 3 connectors (A, B, C) for connecting to car are indicated. Connector A carries the main battery power (B+) wires. Corresponding car connector "A" also shown. The extra W/R wire from my car connector that is not used by my current seats powers lumbar/bolster I think.

Unfortunately, connectors A and B on new seats (lower picture) do not fit corresponding car connectors (connector C fits).

In order to allow all seat movement, I think connector "1" on module of new seat is where I need to get power and ground input from my car connector "A" wires.

The 3 power (B+) wires on new seats appear to be yellow/red (Y/R), brown/red (Br/R) and blue/red (Bu/R) with 3 black (B) ground wires. However, my car connector A has blue/red (Bu/R), green/red (Gr/R) and white/red (W/R) as power inputs I think. Also 3 black ground wires. See wiring diagrams on next page, which helped me figure this out.

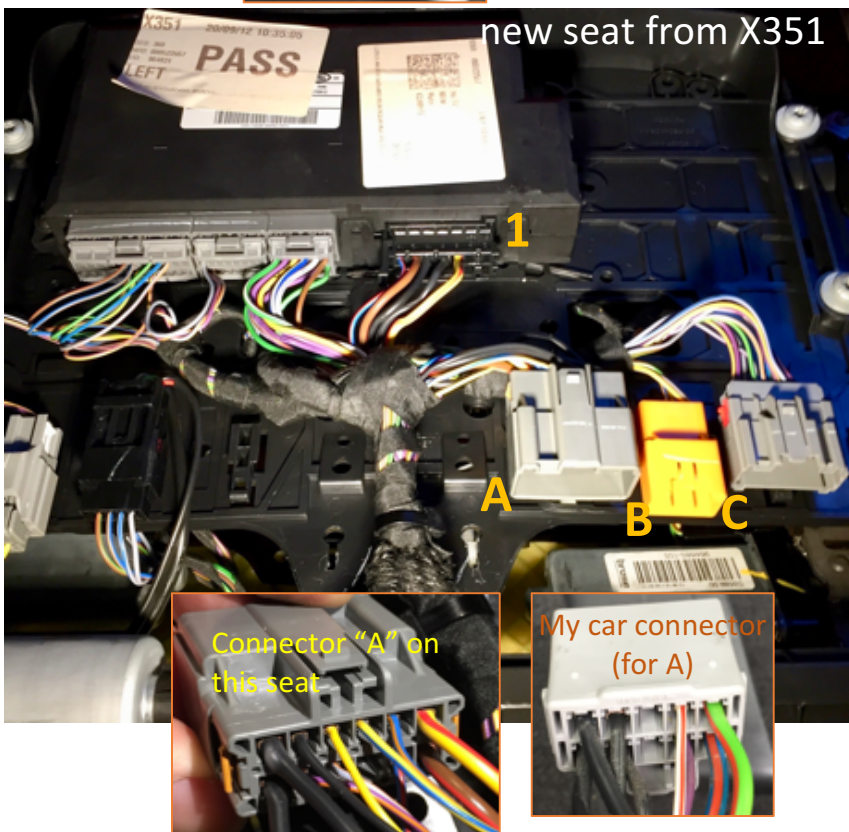

So, how do I connect the correct wires from my car connector "A" to new seat connector "A" so that power goes to seat module connector "1" to at least move the seat correctly?

I would go for following:

Car "A"	→	new seat "A"
Bu/R wire	→	Y/R wire
Gr/R wire	→	Br/R wire
W/R wire	→	Bu/R wire (lumbar)

P/Gr wire → Bu/Br wire?  
 (not sure about this, but probably power for seat heating. No blue/red wire in seat wiring diagrams for X351 heated seats however? Should be brown-green.

Not sure about all the other connections and how to get heating and memory working.

# Wiring diagrams for front seats from X351(XJ) and X250(XF)

## Wiring diagram for driver seat from X351 (ones I have bought)

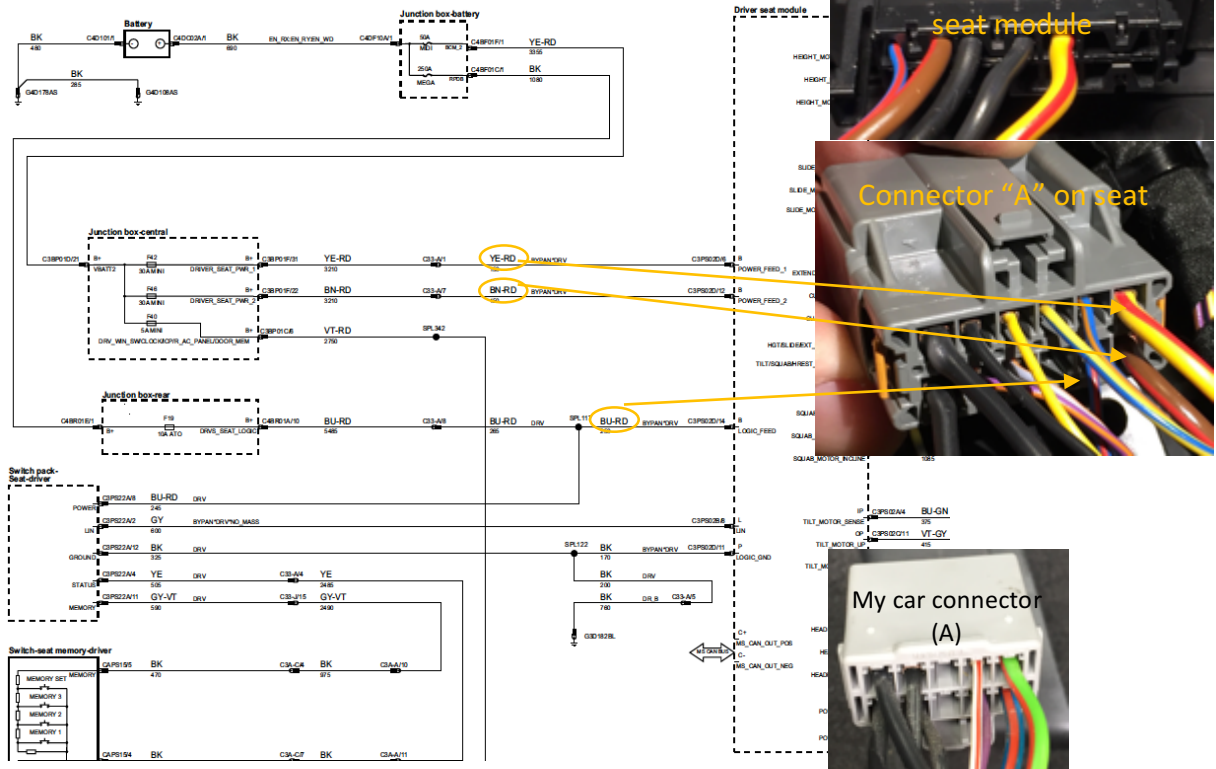

## Wiring diagram for driver seat from my XF (I think...):

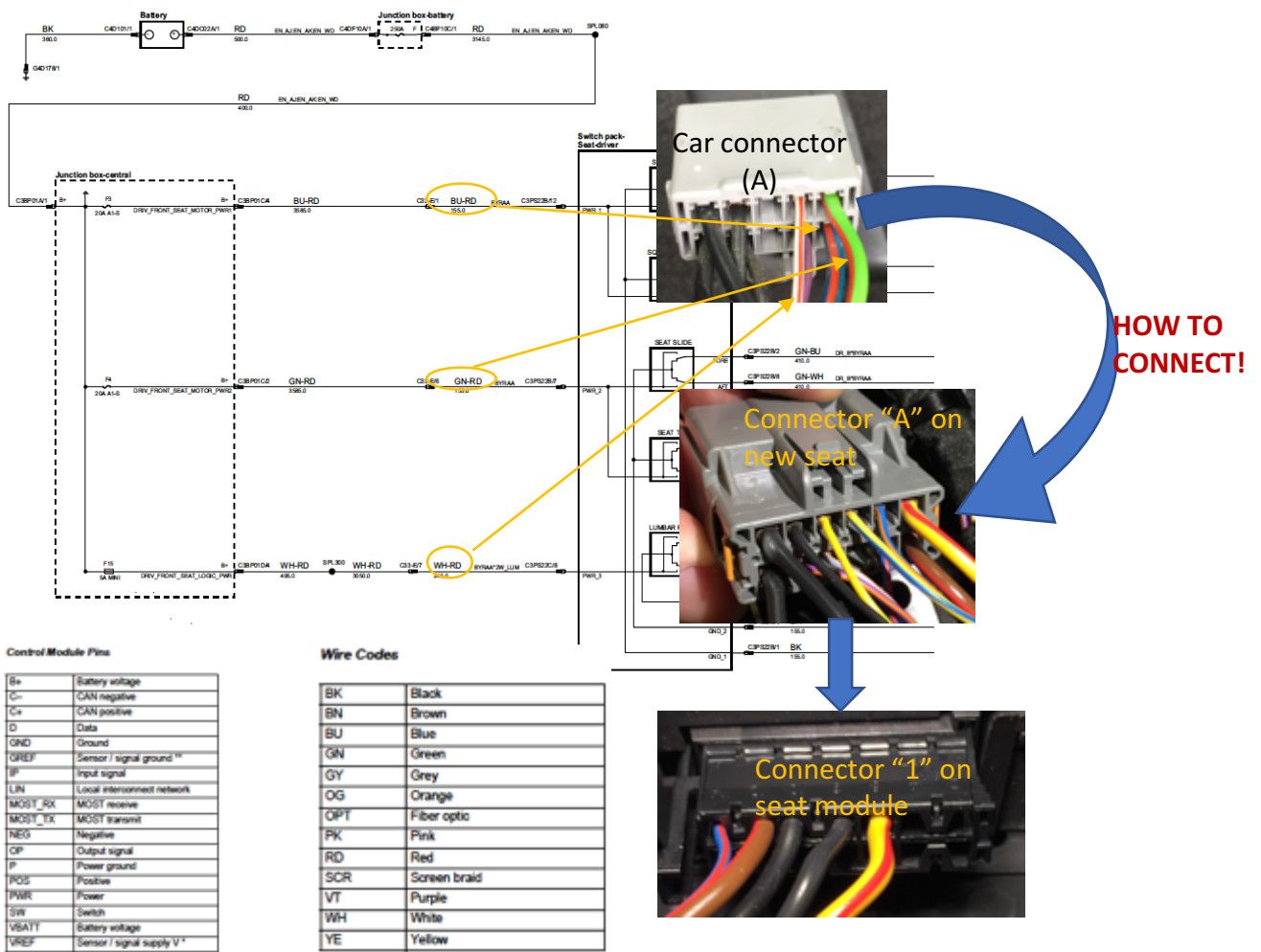

# Wiring diagrams for front seats from X351(XJ) and X250(XF)

Above is X351 seat wiring (12-way memory positioning)

The 3 seat connectors with wire positions (X351) --> for connection with car sockets.

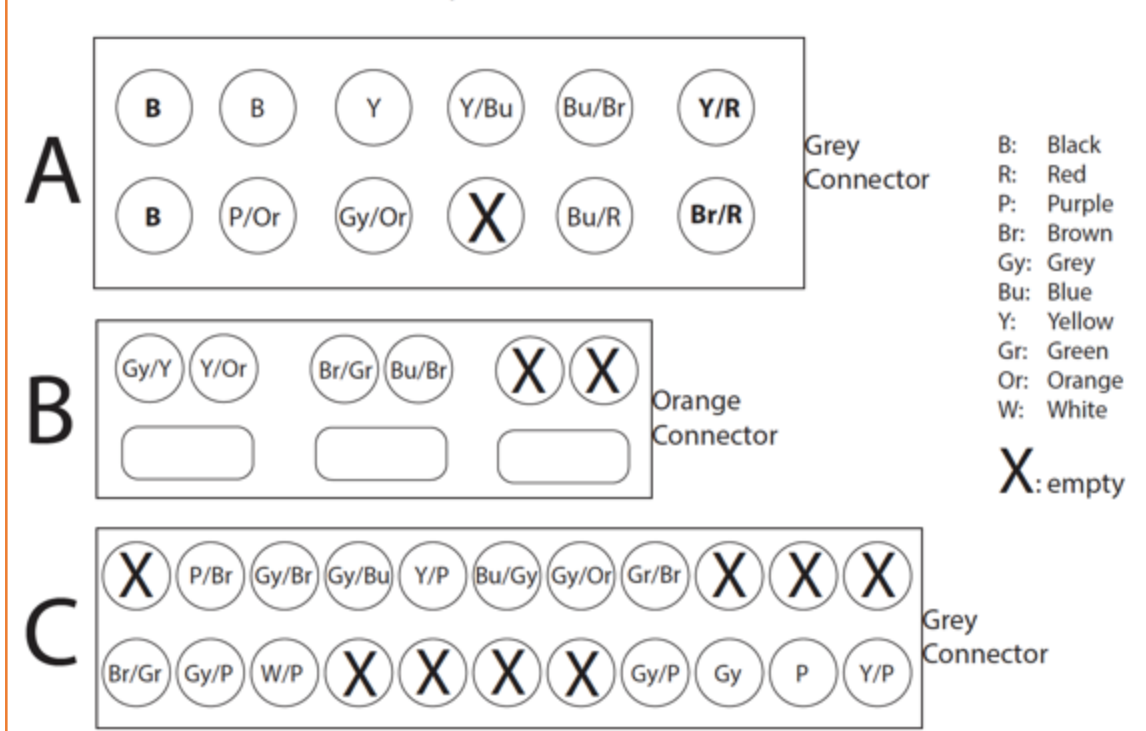

The new seat connectors (above) are different to my original seat connectors with respect to wire colours and number of wires.

In addition, connectors A and B are different shapes and do not even fit to the connectors in my car! I will probably have to cut off the original seat connectors and splice onto new seats.

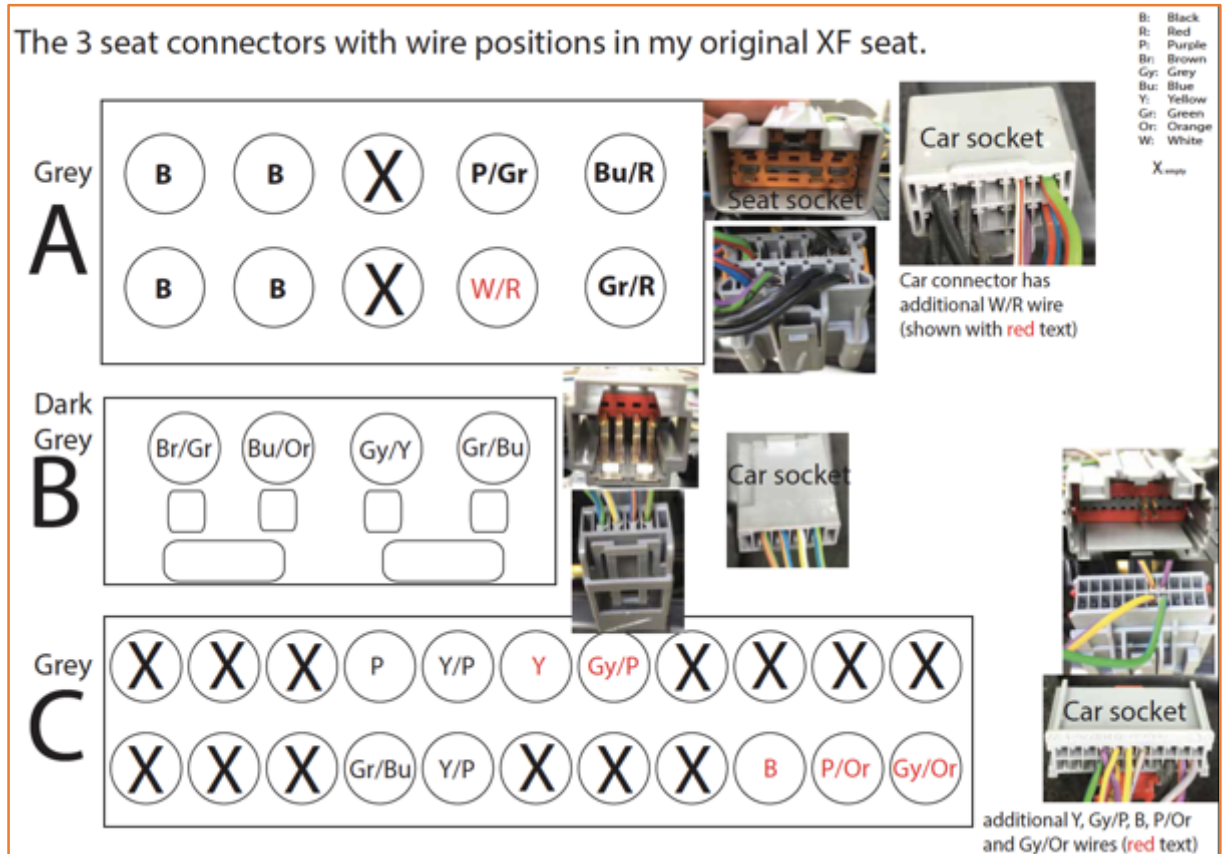

Wiring diagrams for front seats from X351(XJ) and X250(XF)

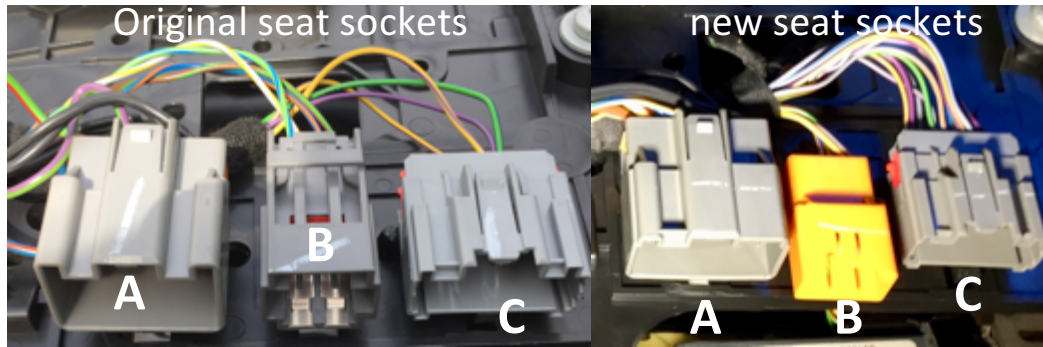

Pictures of the 3 seat connectors in my car (2011 XF) and corresponding connectors on **original** seats in car (heated seats with only 2 positioning levers on side):

Car sockets

Corresponding original seat sockets

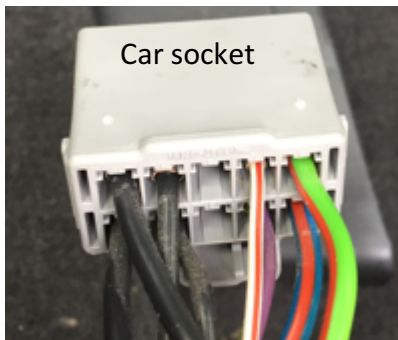
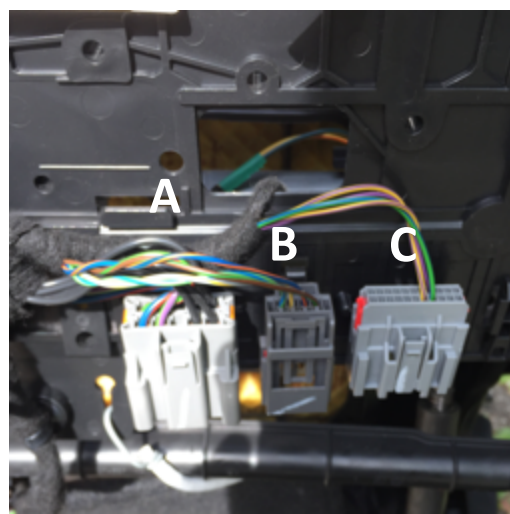
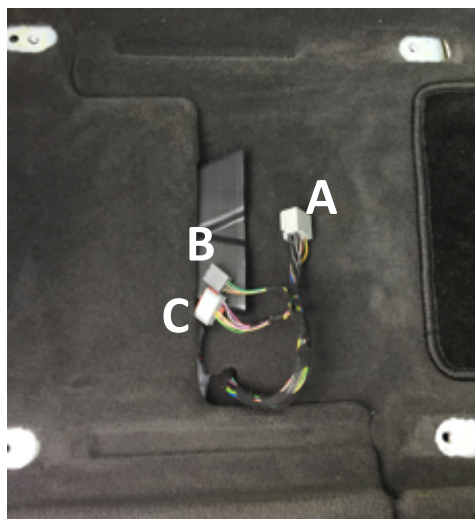

**A**

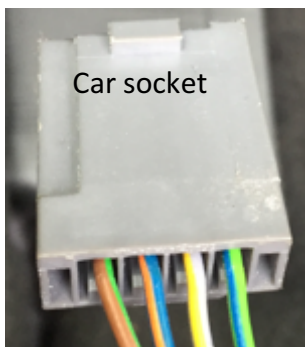
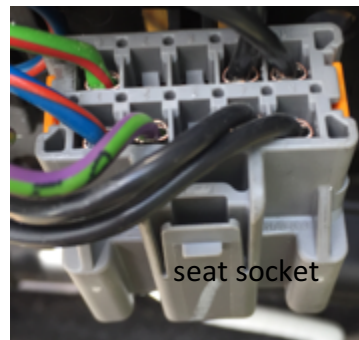

**B**

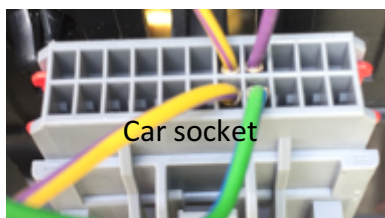
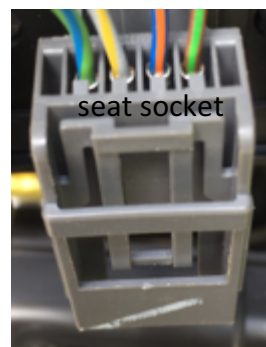

**C**



