

## VARIABLE CAMSHAFT TIMING

### Overview

The camshaft torque-actuated, dual independent Variable Camshaft Timing (VCT) system constantly controls camshaft timing to deliver optimum power, efficiency, and emissions. With dual independent camshaft phasing, the intake and exhaust camshafts can be phased independently of each other.

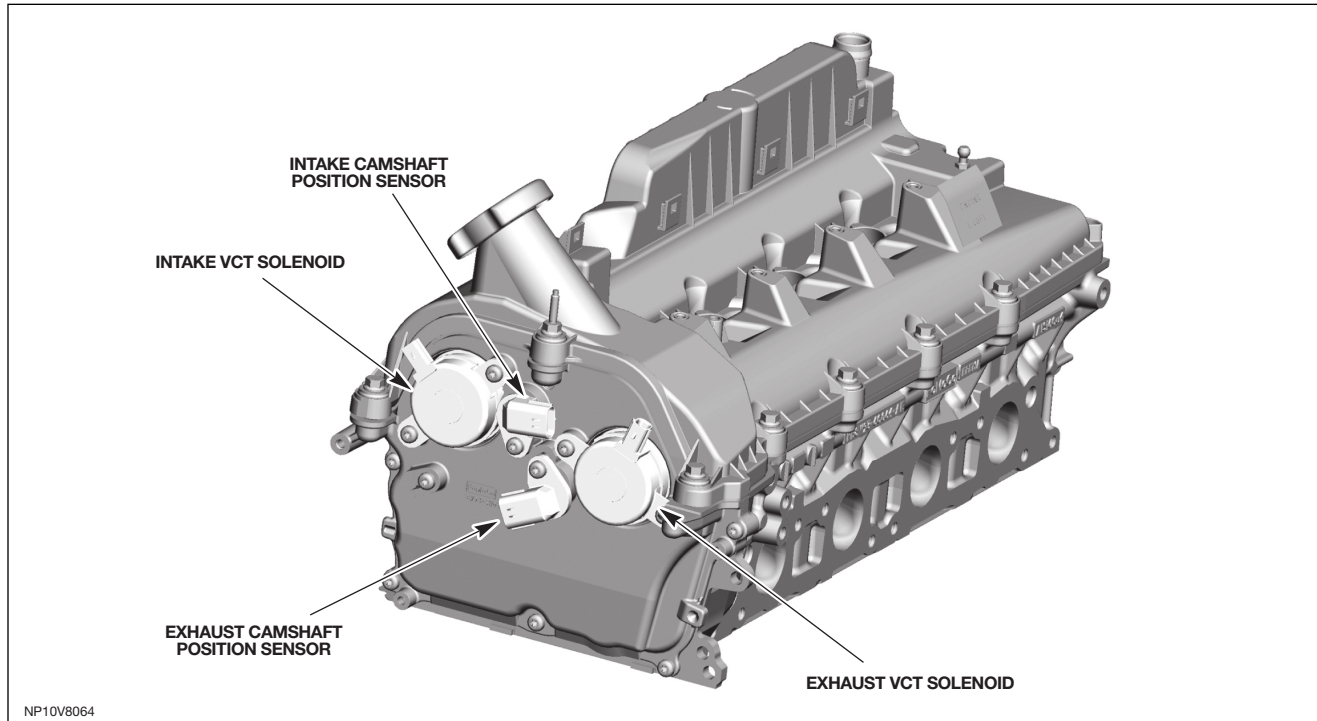

The chain-driven camshaft timing units are mounted on the end of each camshaft, and advance or retard the camshaft timing to thereby alter the camshaft-to-crankshaft phasing. The control solenoids act on hydraulic control valves within each VCT unit to control angular position using camshaft torsional energy to alter the phase. This provides the most flexible method of camshaft phasing, allowing the overlap of exhaust valve closure and intake valve opening to be varied.

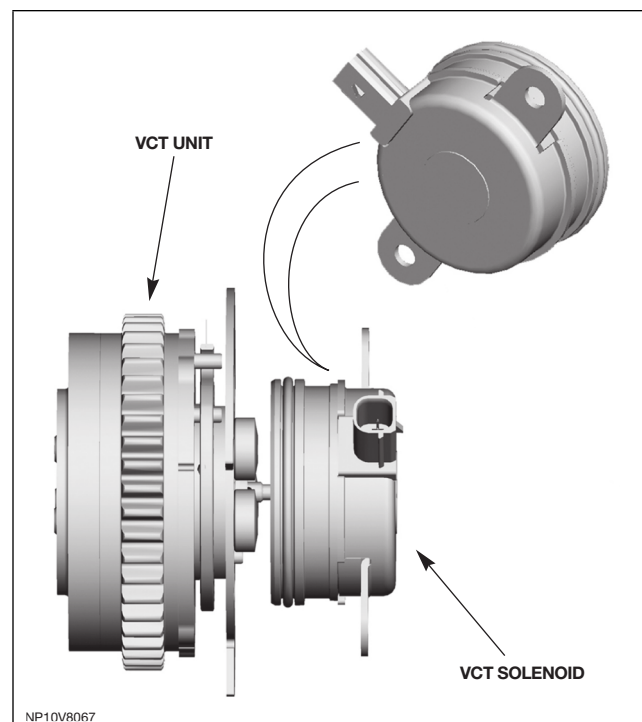

Variable Camshaft Timing Unit – Exploded View

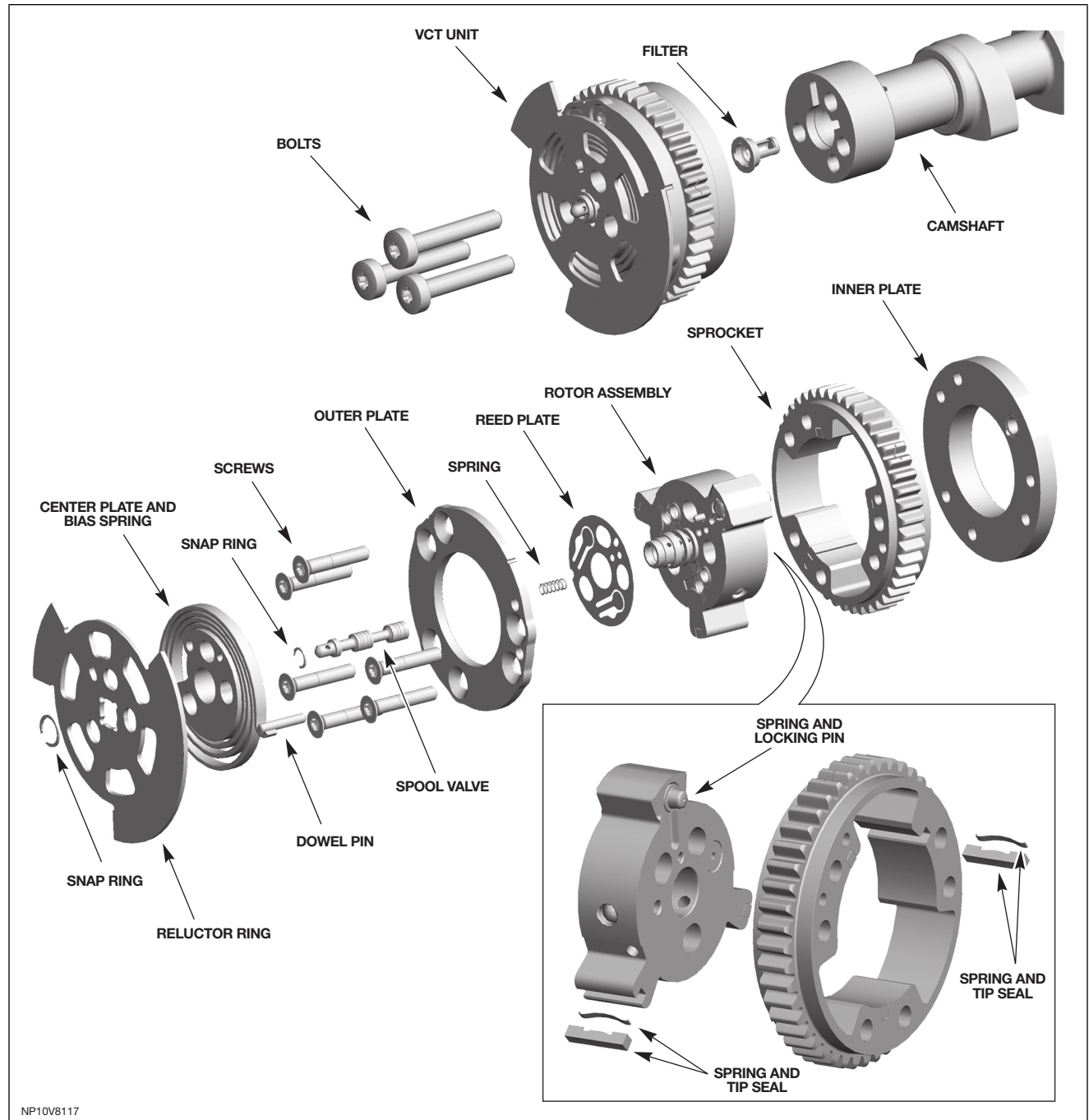

**⚠ CAUTION:** Do not reuse the VCT units if they have been subjected to an impact (such as being dropped on the floor).

Camshaft torque-actuated VCT technology uses camshaft torsional energy generated by the camshaft lobes acting against the valve springs and inertia of the valve train components to phase the camshafts, rather than using oil pressure generated by the oil pump. Angular phasing is achieved by the internal transfer of oil between the chambers of the phaser, via check valves, controlled by a hydraulic control valve – in essence a controlled hydraulic ratchet device. As a result, camshaft torque-actuated VCT technology has a much lower oil demand than that of oil-pressure actuated VCT units (approximately 15%). The reduction in oil demand allows the engine oil pump capacity to be reduced, resulting in fuel economy benefits.

As camshaft torque-actuated VCT technology is not reliant on engine oil pressure to phase the camshafts, response rates at low engine speeds and high temperatures – where engine oil pressure is typically low – is significantly improved. This translates to improved transient performance and response (performance feel).

Camshaft Torsional Energy (for a Single Valve Event)

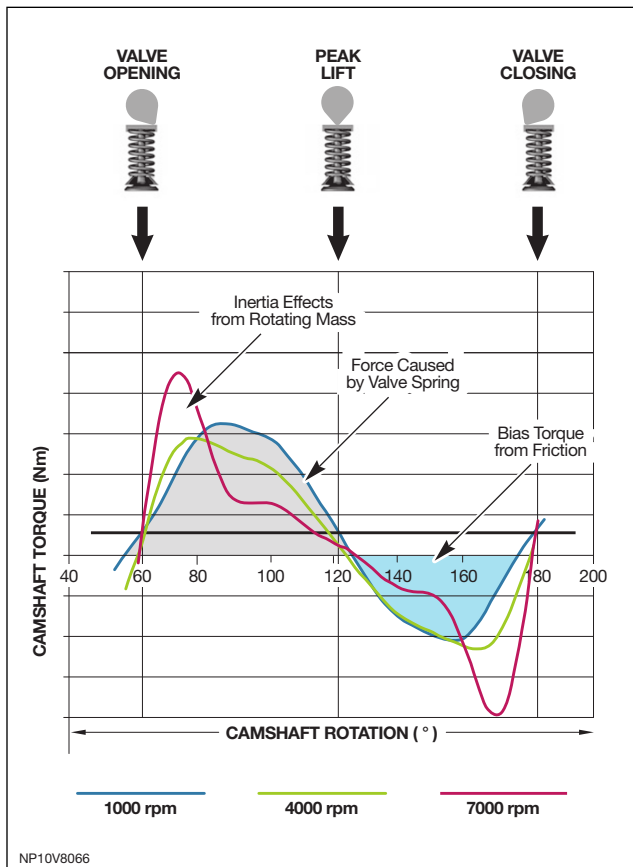

### VCT Operation

The required position of each camshaft is controlled in closed-loop from the ECM, by actuation of a variable force solenoid against the VCT hydraulic control valve at the front of each unit, with reference to signals from the four camshaft position (CMP) sensors and the crankshaft position (CKP) sensor.

The VCT solenoid force is controlled with a pulse width modulated (PWM) duty cycle at battery voltage. When the VCT solenoid is not energized, the phaser pintle is fully extracted (via spring force), locking the camshaft in the base timing position.

The intake camshafts will be in full retard and the exhaust camshafts will be in full advance. Under operation, the intake camshafts can advance 62° crankshaft angle; the exhaust camshafts can retard 50° crankshaft angle.

To hold the camshafts in any other position other than the base timing lock position, the ECM partially energizes the solenoids – holding them in the ‘null’ position. To retard the intake camshafts, the opposite is true, where the VCT solenoid is powered with a lower duty cycle and then returns to the null position once the target angle is reached.

The exhaust camshafts operate in the opposite manner to the intake camshafts, where the solenoid is energized to retard the exhaust camshafts and underpowered to advance the camshafts.

The control from the 'null' position is exponential, whereby the camshafts will advance or retard at a faster rate with a duty cycle displacing the pintle further from the 'null' position.

The major components within the system are:

- A single-source oil feed via a camshaft bearing through the camshaft to the VCT
- An inlet check valve to the VCT
- A common passage that always communicates with the center of the control valve and leads to the high-pressure check valves for the advance and retard hydraulic chambers
- A control valve that is used to control the direction and rate of oil flow from one hydraulic chamber to another and a mechanical spring loaded locking pin that is released on command by hydraulic oil pressure

The oil supplied to the VCT is necessary to fill the VCT initially and then supply a continuous amount of oil to replenish any oil that leaks back from the VCT.

### Oil Recirculation

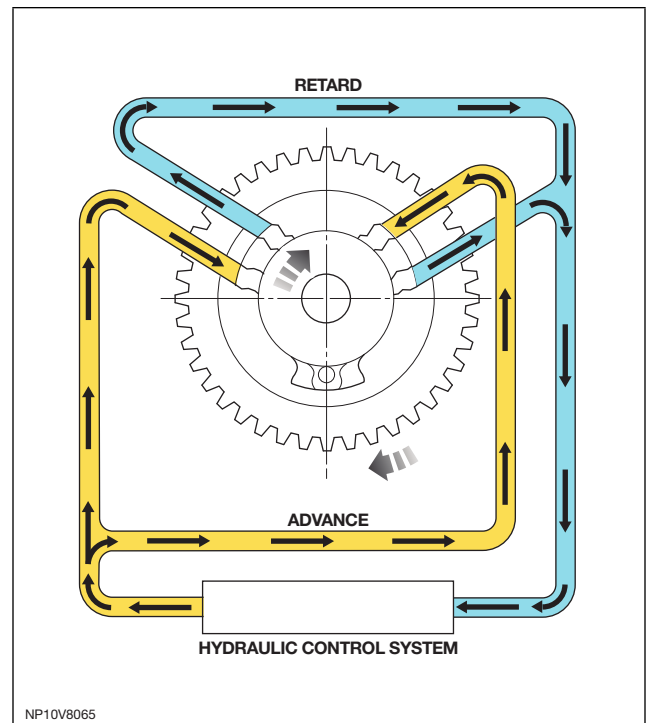

**NOTE:** By supplying source oil to both chambers via a common passage the force, due to oil pressure, is balanced on opposing sides of the vane. Therefore oil pressure does not cause the rotor to move relative to the housing.

After the initial filling the VCT is ready to actuate and control.

The first function of the control valve as it moves to the right is to selectively apply source oil pressure to the locking pin on command. In this control valve position, the locking pin has been commanded to release but the control valve has not reached the position where the VCT is being commanded to move yet. Therefore no force bias is applied to the VCT before releasing the locking pin.

### Camshaft Advance

The camshaft torque-actuated VCT uses the camshaft torque energy to move while recirculating the oil within the VCT from one chamber to the other chamber. The control valve will continue to move to the right and open an exhaust port from the retard chamber to the common passage. During each valve-closing event, when negative camshaft torques are generated, the oil in the retard chamber is pressurized. By opening the exhaust port during valve closing events, oil is allowed to flow from the retard chamber, through the common passage past the advance chamber check valve, to the advance chamber via. The VCT advances an incremental amount with each valve-closing event. During valve-opening events, the advance chamber will be pressurized but no flow will occur because the advance chamber check valve is closed while the control valve has the advance chamber exhaust port blocked.

As a result, with each valve-closing event, oil from the retard chamber flows to the advance chamber, causing the VCT to advance. During the valve opening events when the camshaft torque is positive, the VCT holds position.

The control valve not only controls the direction of flow but also controls the rate of flow from one chamber to the other chamber by means of a variable size opening at the exhaust port.

**NOTE:** When VCT reaches the advance stop, the control valve returns to the null or centered position.

### Camshaft Retard

The VCT retards during valve-opening events by moving the control to the left and opening the exhaust port from the advance chamber. The VCT moves to retard with each valve-closing event and holds position during the valve-opening events. Since this VCT is operated under closed loop control motion, the VCT can be stopped at any moment and in any position by returning the control valve to the centered or null position. Even though there is pressure in both chambers from the positive and negative camshaft torque energy, the VCT is not moving because all exhaust ports from the hydraulic chambers are blocked by the high-pressure check valves and the centered control valve.

When the VCT is commanded to move to the fully retarded position, the control valve moves to the left. At the end of the VCT travel, the mechanical locking pin will align with its receiver and engage. The locking pin is allowed to engage because the control valve, when in the extreme left position, simultaneously blocks source oil pressure from reaching the locking pin and opens a vent to allow the oil in the locking pin passage to vent.

This is the default position for the VCT, which can occur by command, or can occur as a failsafe mode if power to the VCT control system is lost. This event can occur in less than 300ms from any phase position and at any engine speed.

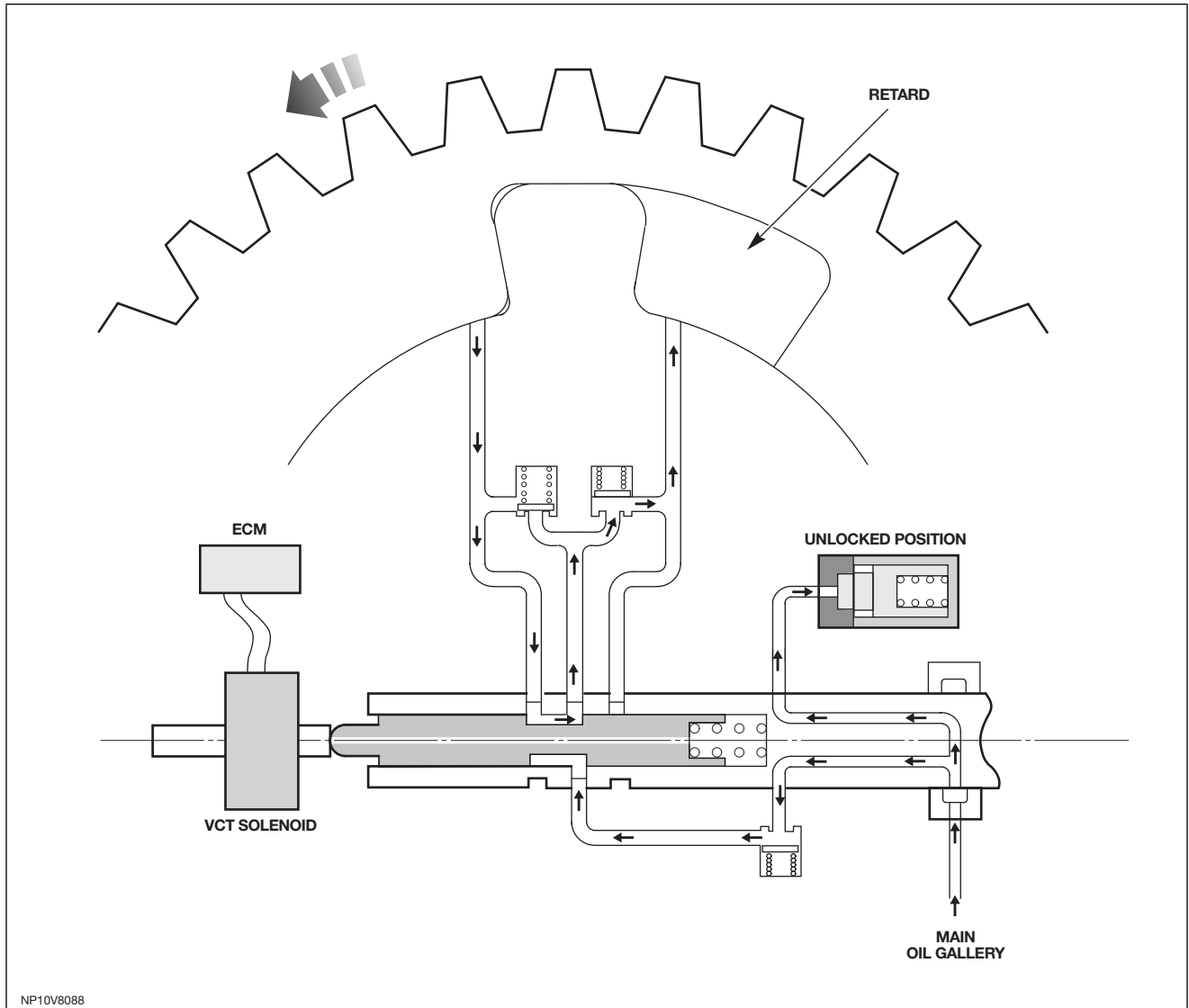

The VCT solenoid is powered directly from V battery (Pin 2) through the ECM controlled relay, with a low side driver in the ECM connected to Pin 1 on the VCT solenoid.

**Safety Precautions**

**⚠ WARNING: The VCT solenoids are heat generators, and can reach high temperatures.**

**Failure Modes**

- VCT Solenoid Stuck
- VCT Phaser Stuck

**Failure Symptoms**

- No VCT Control