

2012.0 XJ RANGE (X351), 206-05

PARKING BRAKE AND ACTUATION

PARKING BRAKE CABLE TENSION RELEASE [G1272017]

GENERAL PROCEDURES

SPECIAL TOOL(S)



RELEASE

Electric parking brake release tool 206-082. Only to be used for EMERGENCY brake



RELEASE

Electric parking brake release tool link lead 206-082-01. Only to be used for EMERGENCY brake

WARNING:

Failure to release the tension and calibrate the electric parking brake during rear parking brake related service procedures, could cause the parking brake to function incorrectly or become inoperative.

1.

WARNING:

Always use Jaguar approved diagnostic equipment to release the cable tension, when carrying out repair operations on the electric park brake which require cable tension release.

Connect the Jaguar approved diagnostic equipment to release the electric parking brake cable tension.

- Follow the on-screen instructions.

2.

WARNING:

The procedure below should only be used in emergency situations, to release the electric park brake. All calibration of the parking brake system will be lost, and the parking brake will need to be re-calibrated to function correctly.

NOTE:

The tools shown must only be used in the event of an emergency.

Remove the RH loadspace trim panel.

For additional information, refer to: [Loadspace Trim Panel RH](#) (501-05 Interior Trim and Ornamentation, Removal and Installation).

3.

WARNING:

Failure to follow this instruction may result in a diagnostic trouble code (DTC) being generated.

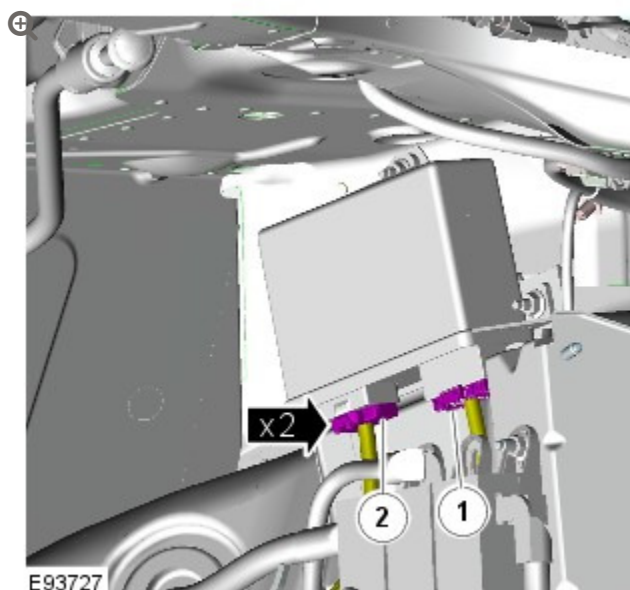

Disconnect the 2 electrical connectors from the parking brake module, in the sequence illustrated.

4.

NOTE:

Some variation in the illustrations may occur, but the essential information is always correct.

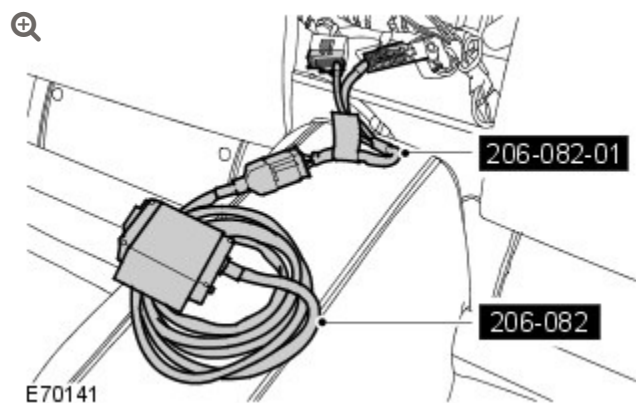

Connect the special tool to the parking brake module.

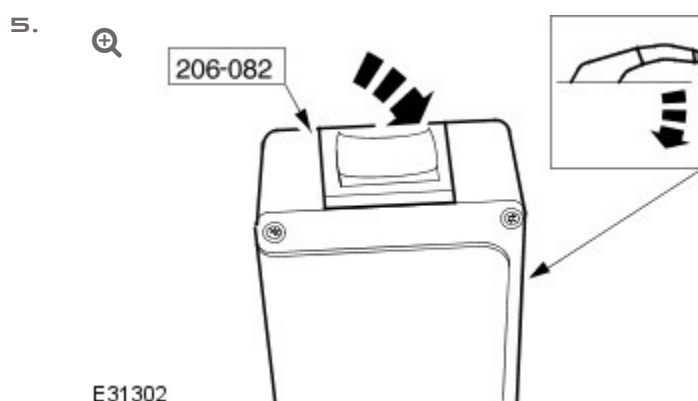

Release the parking brake cable tension.

- An audible 'click', signals complete parking brake cable tension release.

6. Remove the special tool and carry out any necessary repairs on the system.

7.

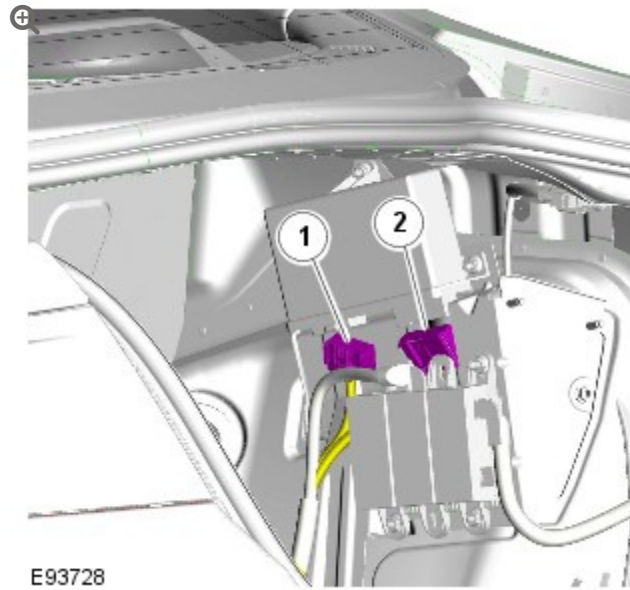

Connect the electrical connectors in the sequence shown.

8. Install the RH loadspace trim panel.

For additional information, refer to: [Loadspace Trim Panel RH](#) (501-05 Interior Trim and Ornamentation, Removal and Installation).

9. **WARNING:**

Calibrate the electric park brake using Jaguar approved diagnostic equipment. If Jaguar approved diagnostic equipment is not available disconnect the battery for approximately 30 seconds, the vehicle will then prompt the driver to carry out the calibration procedure as per the vehicle hand book on re-connection.

Calibrate the electric park brake.