



TECHNICAL BULLETIN

UPS5511-1bNAS2

17 FEB 2012

Update Prior to Sale Notice UPS5511 is superseded by Service Action K117

All Warranty claims up to the date of expiration must be submitted for payment within 30 days of completion of repair.

NOTE: The information in Technical Bulletins is intended for use by trained, professional Technicians with the knowledge, tools, and equipment required to do the job properly and safely. It informs these Technicians of conditions that may occur on some vehicles, or provides information that could assist in proper vehicle service. The procedures should not be performed by 'do-it-yourselfers'. If you are not a Dealer, do not assume that a condition described affects your vehicle. Contact an authorized Jaguar service facility to determine whether this bulletin applies to a specific vehicle.



TECHNICAL BULLETIN

UPS5511-1bNAS2

17 FEB 2012

THIS UPDATE PRIOR TO SALE NOTICE IS SUPERSEDED BY SERVICE ACTION K117

SECTION: 501

Update Prior to Sale: Panoramic Roof 'Creak'

AFFECTED VEHICLE RANGE:

XJ (X351)

VIN: V22248 – V24460 (standard wheelbase; specific USA vehicles only)

V22232 – V24700 (long wheelbase; specific USA vehicles only)

Model Year: 2012

CONDITION SUMMARY:

Situation: In order to ensure that XJ vehicles are supplied with the very latest parts to enhance the owner's experience of these vehicles, vehicles within the above VIN ranges require a number of minor updates prior to vehicle handover to the owner.

Action: Dealers are required to '**HOLD**' the affected vehicles within your control and refrain from releasing the vehicles for onward distribution and sale pending completion of the rework action detailed in this Technical Bulletin. For vehicles in dealer inventory, this UPS should be performed in conjunction with the vehicle Pre-Delivery Inspection (PDI). For vehicles in dealer inventory which have already had the PDI completed, this UPS should be completed prior to final preparation / customer handover.

Vehicles already in the hands of owners may be updated as required at their earliest customer prior to the expiration date. At the time of customer appointment, ensure that all outstanding service campaigns for each individual vehicle are identified and allocate sufficient time and resources to complete all campaigns.

PARTS:

C2D23230Service kit

Qty: 1

TOOLS:

Refer to Workshop Manual for any required special tools

WARRANTY:

△ NOTE: Repair procedures are under constant review, and therefore times / prices are subject to change; those quoted here must be taken as guidance only. Always refer to DDW to obtain the latest repair time. Check DDW to ensure that the vehicle is affected by this Update Prior to Sale notice prior to undertaking any rework action. Ensure that all outstanding Service Actions are identified to ensure the correct parts are available and adequate workshop time is allocated for repairs to be completed at one visit.

Warranty claims must be submitted quoting Program Code '**K117**' together with the relevant Option Code from the table. The SRO and part information listed have been included for information only. The Option Code that allows for the drive in / drive out allowance can only be claimed if the vehicle is brought back into the workshop for this action alone to be undertaken.

This Update Prior to Sale notice is valid for a limited time only. Warranty claims with a repair date prior to the **29 February 2012** closure date must be submitted for payment within 30 calendar days of completion of the repair.

NOTE: The information in Technical Bulletins is intended for use by trained, professional Technicians with the knowledge, tools, and equipment required to do the job properly and safely. It informs these Technicians of conditions that may occur on some vehicles, or provides information that could assist in proper vehicle service. The procedures should not be performed by 'do-it-yourselfers'. If you are not a Dealer, do not assume that a condition described affects your vehicle. Contact an authorized Jaguar service facility to determine whether this bulletin applies to a specific vehicle.

PROGRAM CODE	OPTION CODE	DESCRIPTION	SRO	TIME (HOURS)	PART NUMBER	QTY.
K117	B	Install Service kit; set opening panel alignment	76.95.85	1.70	C2D23230	1
K117	C	Install Service kit; set opening panel alignment	76.95.85	1.70	C2D23230	1
		Drive in / drive out	10.10.10	0.10	-	-

Normal Warranty policies and procedures apply

REPAIR PROCEDURE

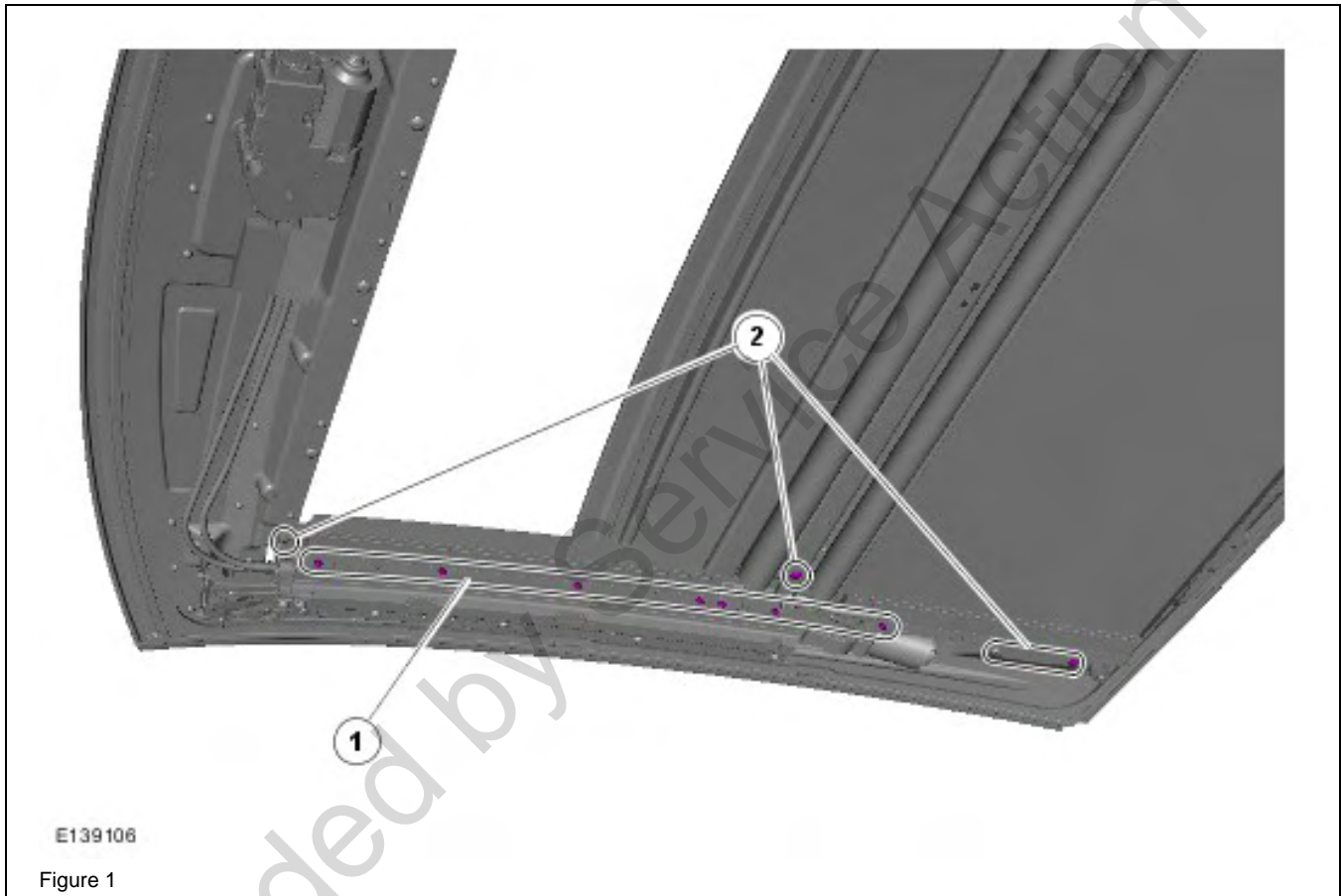

△ **NOTE:** Right-hand (RH) side shown; left-hand (LH) side similar.

△ **NOTE:** Long Wheelbase (LWB) shown; Standard Wheelbase (SWB) similar.

1. Note the fixings affected by this re-work. (Figure 1)

① - rigid fixings.

② - free-to-slip fixings.

⚠ **CAUTION:** Before starting the Workshop Procedure, protect the complete interior of the car from damage, staining or dirt. Make sure suitable clean gloves are worn especially when handling the headliner, blinds etc.

⚠ **CAUTION:** Make sure no damage is caused to the headliner clips when removing the headlining.

2. Fully open the roof opening panel.

- Refer to Workshop Manual, section 501-05: *Headliner*, and carry out steps 4-7 and 9-14.

CAUTION: Make sure the headlining is fully supported, and that the harnesses are not damaged during re-positioning.

3. Refer to Workshop Manual, section 501-05: *Headliner*, and with the aid of another technician carry out steps 16, 17, and 19.
 - Re-position the front seats in to the fully-forward fully-lowered position, the seat backs in the fully-upright position, and the head rests in the fully-lowered position.

CAUTION: The locating peg component can be released during this procedure; make sure that pressure is applied to the component to prevent this.

CAUTION: Note the fitted position of the wind deflector net, spring, and locating peg component prior to removal.

4. Release the wind deflector. (Figure 2)
 - Open the roof opening panel glass to the fully open position.
 - Apply gentle pressure to the locating peg component.
 - Using a suitable tool release the wind deflector arm.
 - Repeat the process to the other side of the vehicle.

CAUTION: Make sure that the locating peg component is correctly installed; failure to follow this instruction may result in damage to the vehicle.

5. If required, install the locating peg component. (Figure 3)
 - Repeat this process to the other side of the vehicle if required.



Figure 2



Figure 3

 **CAUTION:** Make sure that the inner sight shield is not disturbed during this procedure.

 **CAUTION:** Make sure the casting thread is clean and free from burrs.

6. Remove and discard the Torx bolt. (Figure 4)
 - Apply gentle pressure to the trim to aid removal.
 - Remove and discard the Torx bolt.
 - Remove any residual traces of locking adhesive from the casting threads and the fixing mating faces.

7. Note the position of the washers within the roof assembly. (Figure 5)



Figure 4

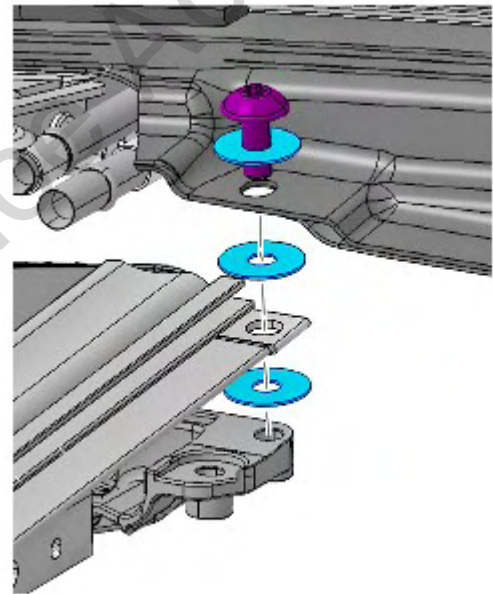

Figure 5

8. Install the middle washer. (Figure 6)

- If required, apply gentle downwards pressure to create a sufficient gap between the mating surfaces.
- Slide the washer in from the front of the vehicle until it is aligned with the hole.

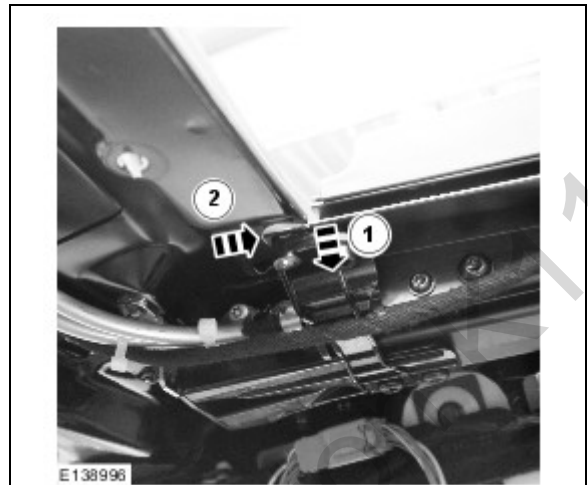

Figure 6

9. Install the lower washer. (Figure 7)

- Using a suitable tool, apply a gentle pressure to create a sufficient gap between the mating surfaces.
- Slide the washer in from the front of the vehicle until it is aligned with the hole.

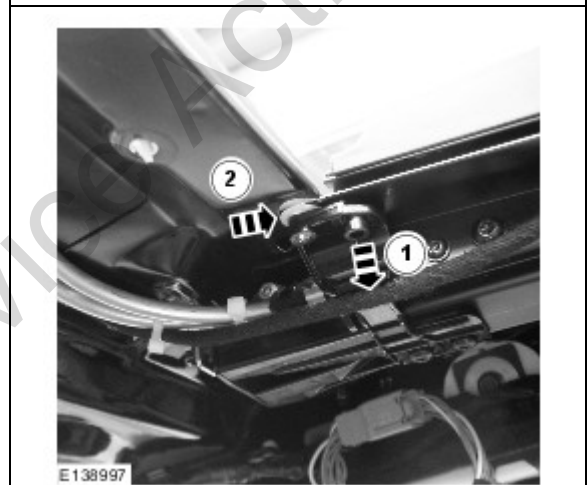



Figure 7

 **CAUTION:** Make sure that the three washers are correctly aligned with the hole.

10. Install the upper washer. (Figure 8)

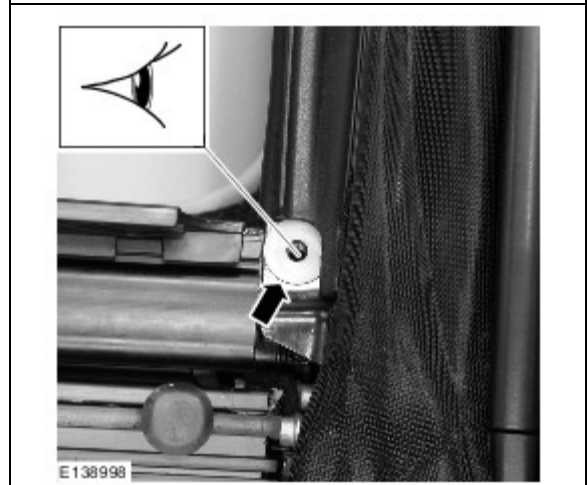

Figure 8

CAUTION: Make sure that the Torx bolt is not cross threaded during installation.

CAUTION: Make sure that the Torx bolt is tightened by hand; do not use air tools.

CAUTION: Make sure the casting thread is clean and free from burrs.

11. Install the new Torx bolt. (Figure 9)

- If required, apply gentle pressure to the trim.
- Tighten the Torx bolt to 4 Nm.
- If the upper washer is free to rotate after the fixing is tightened, progressively tighten the Torx bolt until the upper washer is fully clamped.
- Tighten the Torx bolt a further 90 degrees.

12. Repeat steps 6-11 to the other side.

CAUTION: Make sure the locating peg component is correctly located.

CAUTION: Make sure the spring is correctly located.

13. Install the wind deflector.

- Carefully install the wind deflector arm to the locating peg component.
- Repeat to the other side.
- If required, adjust the wind deflector net.

CAUTION: On the first operation there may be an audible click; this is normal.

14. Manually check the operation of the wind deflector.

- Press the wind deflector fully down three (3) times.

CAUTION: Make sure the casting thread is clean and free from burrs.

15. Remove and discard the Torx bolt. (Figure 10)

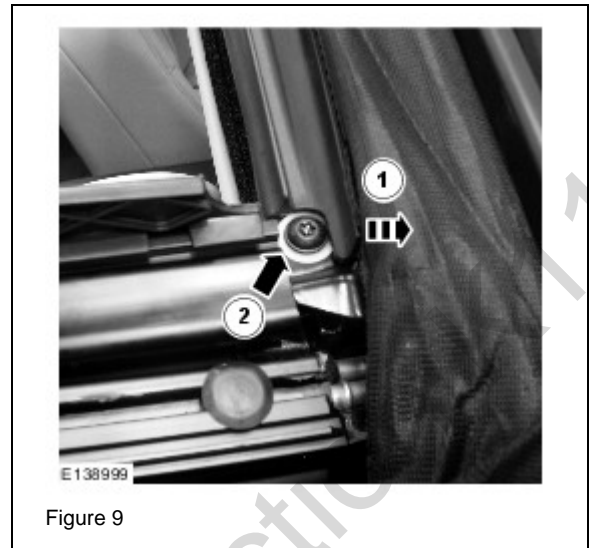

Figure 9

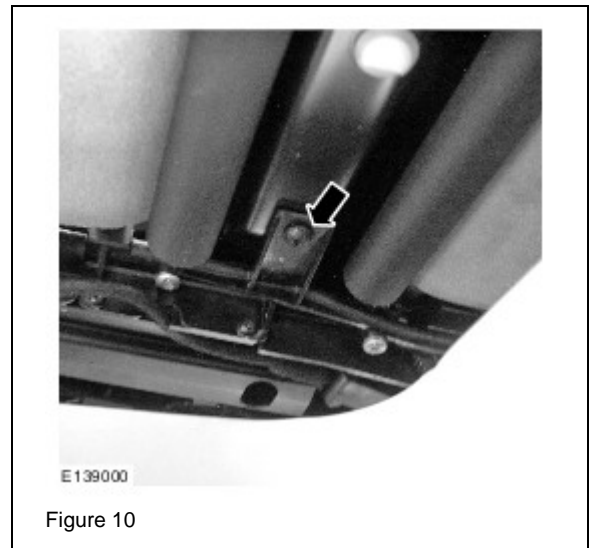

Figure 10

16. Install the upper washer. (Figure 11)

- Slide the washer in between the mating faces until it is aligned with the hole.



Figure 11

⚠ CAUTION: Make sure the casting thread is clean and free from burrs.

17. Install the new Torx bolt. (Figure 12)

- Install a washer to the bolt.
- Tighten the Torx bolt to 4 Nm.
- Repeat the above steps to the other side of the vehicle.

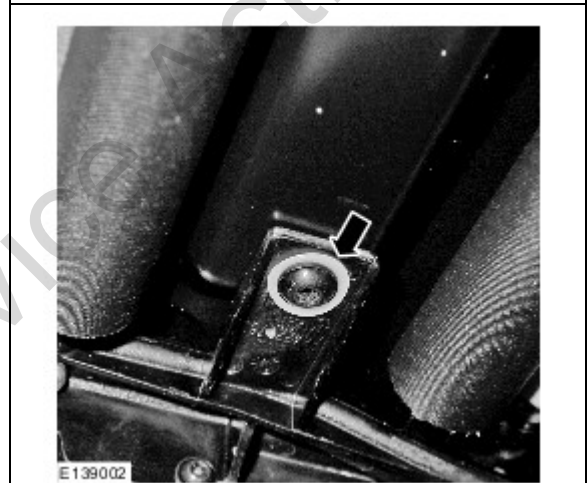

Figure 12

⚠ CAUTION: Make sure the lateral position of the rail is marked before removing the fixings.

⚠ CAUTION: Make sure the casting threads are clean and free from burrs.

△ NOTE: Long Wheelbase (LWB) has two fixings and the Standard Wheelbase (SWB) has one fixing.

△ NOTE: LWB shown; SWB similar.

18. Using a suitable marker, mark the lateral position of the rail. (Figure 13)

- Remove and discard the Torx bolt(s).

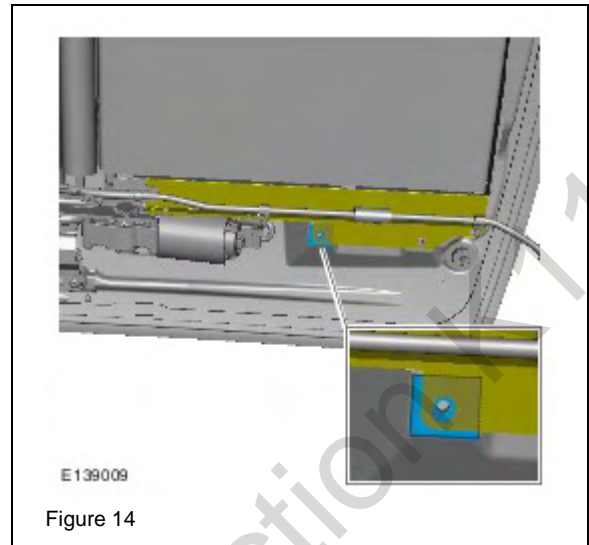

Figure 13

CAUTION: Make sure that the adhesive foam pad is positioned directly above the front fixing hole.

NOTE: LWB only.

19. Install the adhesive foam pad between the mating faces of the discarded front fixing hole. (Figure 14)



NOTE: Do not install a fixing to the front hole on LWB vehicles.

20. Install the upper washer. (Figure 15)

- Slide the washer in between the mating faces until it is aligned with the hole.

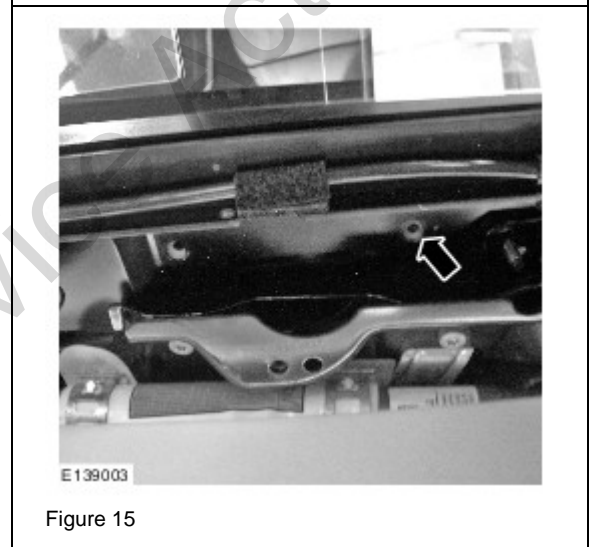

CAUTION: Make sure the casting threads are clean and free from burrs.

21. Install the new Torx bolt. (Figure 16)

- Install a washer to the bolt.
- Align the rail to the marked lateral position.
- Tighten the Torx bolt to 4 Nm.
- Repeat the above steps to the other side of the vehicle.

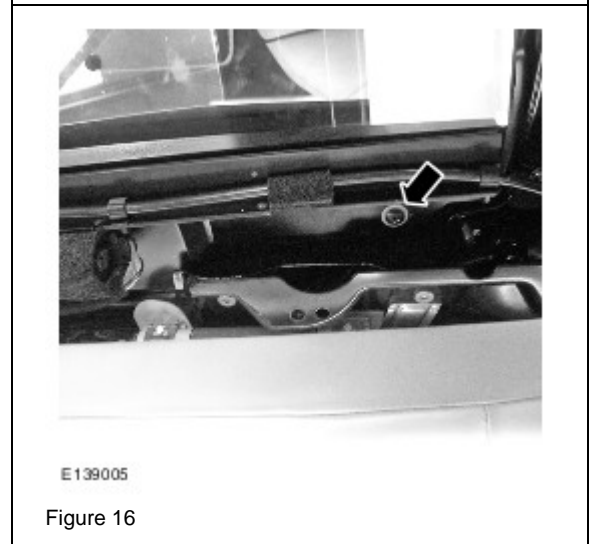

22. Install the Torx bolt and nut. (Figure 17)

- Tighten to 6 Nm.
- Repeat to the other side.

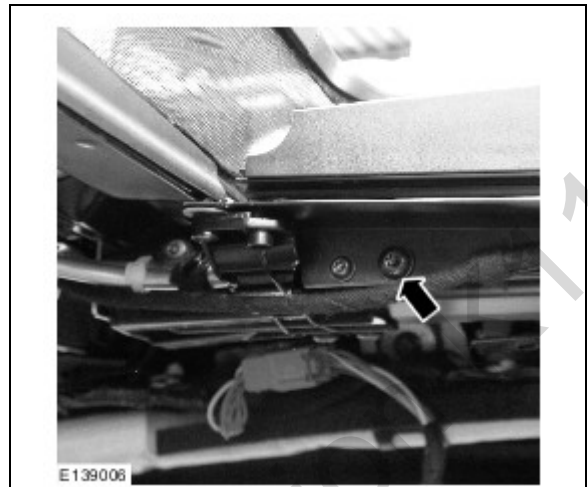



Figure 17

 **NOTE:** Harness shown re-positioned for clarity; make sure the harness is correctly located in to the rail.

23. Install the Torx bolt and nut. (Figure 18)

- Tighten to 6 Nm.
- Repeat to the other side.

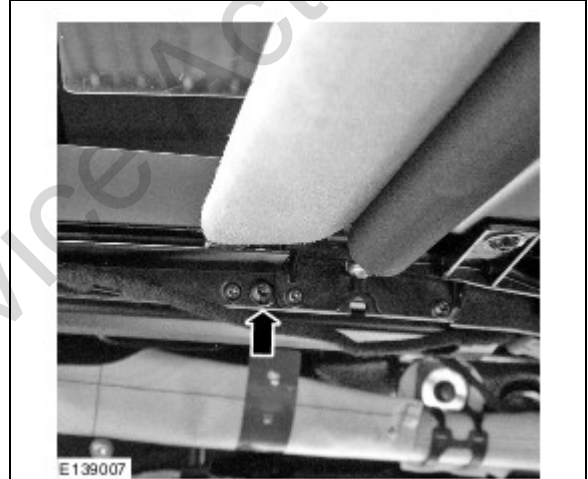

Figure 18

24. Tighten the two Torx bolts to 6 Nm. (Figure 19)

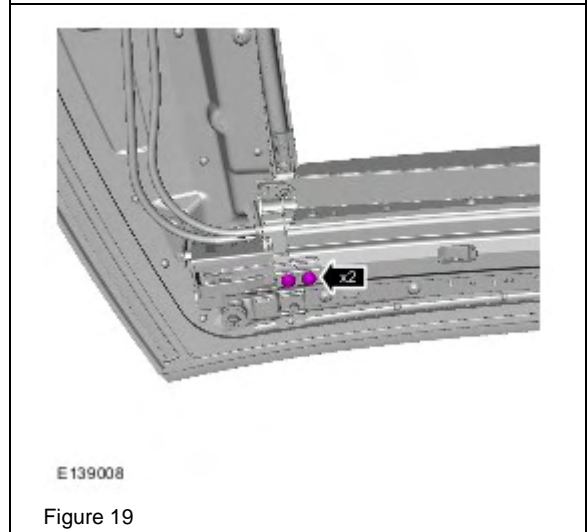

Figure 19



E 139095

Figure 20

25. Make sure that the seven M4 side rail Torx bolts are tightened to 3 Nm. (Figure 20)

⚠ CAUTION: Make sure when snapping off the alignment pegs that they do not protrude through the slot in the body as this can cause a noise.

△ NOTE: Apply a small amount of grease to the inside of the socket to prevent the broken peg remaining in the vehicle.

26. If present, remove the front windshield locating pegs. (Figure 21)
- Using a suitable 5.5mm, deep socket and extension bar, snap off the pegs.

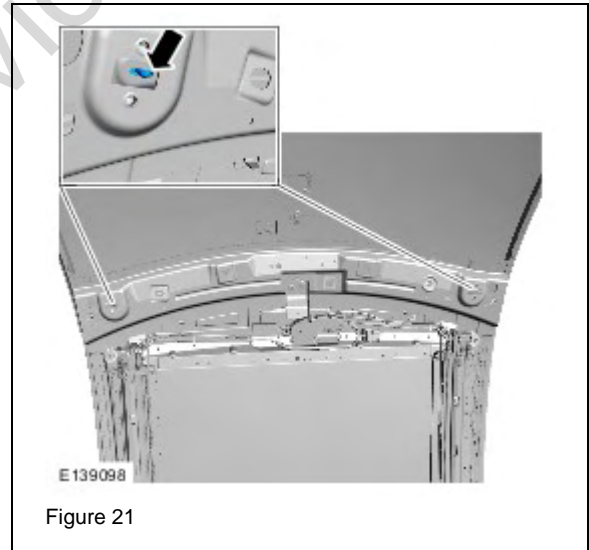

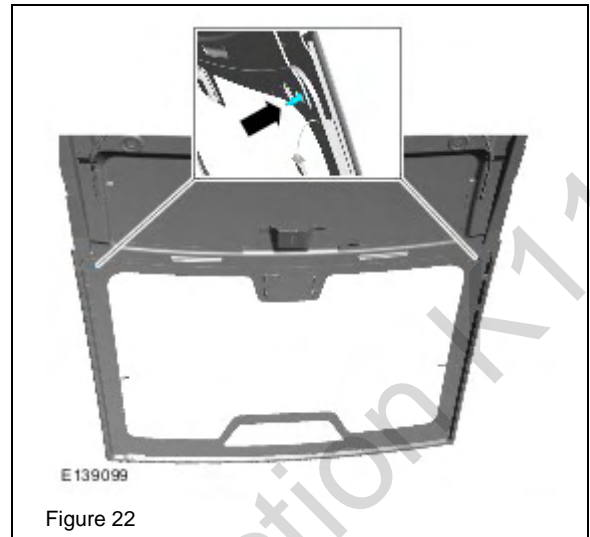

Figure 21

 **CAUTION:** Make sure when snapping off the alignment pegs that they do not protrude through the slot in the body as this can cause a noise.

27. If present, repeat the above step to the rear windshield locating pegs. (Figure 22)



28. To install the headliner, reverse steps 2-3.

29. Check the operation of the one-touch function on the roof opening panel glass, and both blinds.

- Fully close the roof opening panel glass.
- Check the one touch function.
- If the operation of the roof opening panel glass is not normal, check the wind deflector alignment and locating peg position (step 11).

30. Make sure that the rear of the opening glass panel is set to the profile of flush or up to +1mm proud at the rear outer corners. (Figure 23)

- If the roof opening panel glass is outside the above specification, adjust the roof opening panel glass by relaxing the centre and rear fixings.

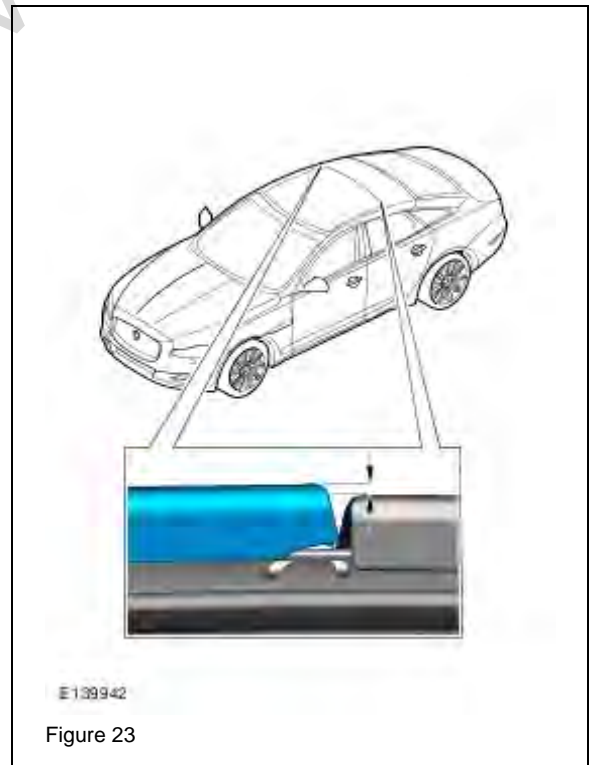



CAUTION: Note the fitted position and gap between the top of the shield and the roof opening panel.

31. If required, adjust the rear fixings to achieve the above specification. (Figure 24)
 - Position the roof opening panel glass to the tilt position.
 - Remove the outer sight shield.

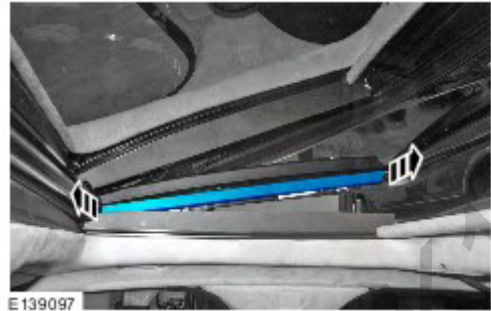

Figure 24

32. Adjust the roof opening panel glass. (Figure 25)
 - Release the two Torx bolts.
 - Allow the roof opening panel glass to settle.
 - Tighten the Torx bolts to 7 Nm.



Figure 25

33. Close the roof opening panel glass and check that the specification has been achieved.
 - If the specification has not been achieved, repeat steps 31 and 32 to achieve the correct alignment of the roof opening panel.
34. Install the outer sight shield.



NOTE: Make sure that the height of the rear edge of the roof opening panel glass is the same on both sides of the vehicle.

35. If required, repeat steps 30-33 to the other side.
36. Road test vehicle to make sure that there are no roof noise concerns present.



NOTE: After installation of the Teflon washers, there may be a subtle noise similar to a squishing type noise that can occur while the Teflon washers bed-in during the first few miles of driving. (The actual distance of the bed-in will vary depending on road conditions.) Ensure that the test drive is long enough to account for the bedding-in of the Teflon washers.

- If no roof noise concerns are present, the vehicle repair is now complete.
- If a noise concern is present, continue the road test with the roof opening panel glass in the vent position.



NOTE: If there is a noise concern with the roof that goes away when the roof opening panel glass is in the vent position, the adjusted position on the roof opening panel is the root cause and the roof opening

panel glass must be re-adjusted to resolve the noise concern.

- If the noise is not present with the roof opening panel glass in vent position, re-adjust the roof opening panel glass to 1 mm above the leading edge of the rear fixed glass panel.
- Repeat the road test after re-adjusting the roof opening panel glass and make sure the noise concern is no longer present.

Superseded by Service Action K1117