



## SALES & MARKETING - 2013 MY XJ PRODUCT BRIEF

**DATE:** May 23, 2012  
**MODEL:** XJ  
**SUBJECT:** 2013 Model Year - Job#1 Specifications

### INTRODUCTION

The 2012 Model Year focused primarily on the top of the XJ line, enhancing the rear environment luxury features of the XJ/XJL Supersport and introducing sport-oriented option packs on the Supercharged and Supersport derivatives. For **2013 Model Year**, the focus is on **powertrain actions** designed to answer increased consumer demand for more efficient engines.

As announced at the Beijing Autoshow last month, Jaguar is launching two new engines, one of which - **the new Supercharged 3.0-liter V6** - will be available on the XJ, raising to four the number of available powertrains on that model line – new V6 Supercharged, V8 Naturally aspirated and V8 Supercharged in both 470hp and 510hp versions. In addition, to further enhance the relevance of the product in the market place, all engines are fitted with an **8-speed automatic transmission** and with **Intelligent Stop/Start**.

The XJ experience is further enhanced at 13MY by the introduction of two new, high quality audio systems, switching from Bowers & Wilkins™ to the **Meridien™** brand. And in response to retailers' request for more brand visual recognition, the "**JAGUAR**" script has been added below the leaper on the center of the rear trunk lid.

As previously announced, at 2013MY we are launching the stunning **XJL Ultimate**. For details regarding this new exclusive addition to the XJ line, please see the separate Product Brief that was issued on April 22<sup>nd</sup>.

These changes and others affecting the XJ model range at 13MY launch are detailed in the Product Brief that follows.

### TIMING

- Job #1 2013MY – June 23, 2012
- Dealer First Order call – anticipated mid-May 2012. Further information regarding retailer ordering will be issued separately by Distribution
- Start of Sales – expected early Q4 2012

### TABLE OF CONTENT

1. New Powertrain and Transmission
2. Other feature changes for 2013 MY
3. Product Line up change summary
4. Color, Trim & Veneer
5. Wheels

## 1. NEW POWERTRAIN AND DYNAMICS

### 1.1 New Jaguar 3.0L V6 Engine

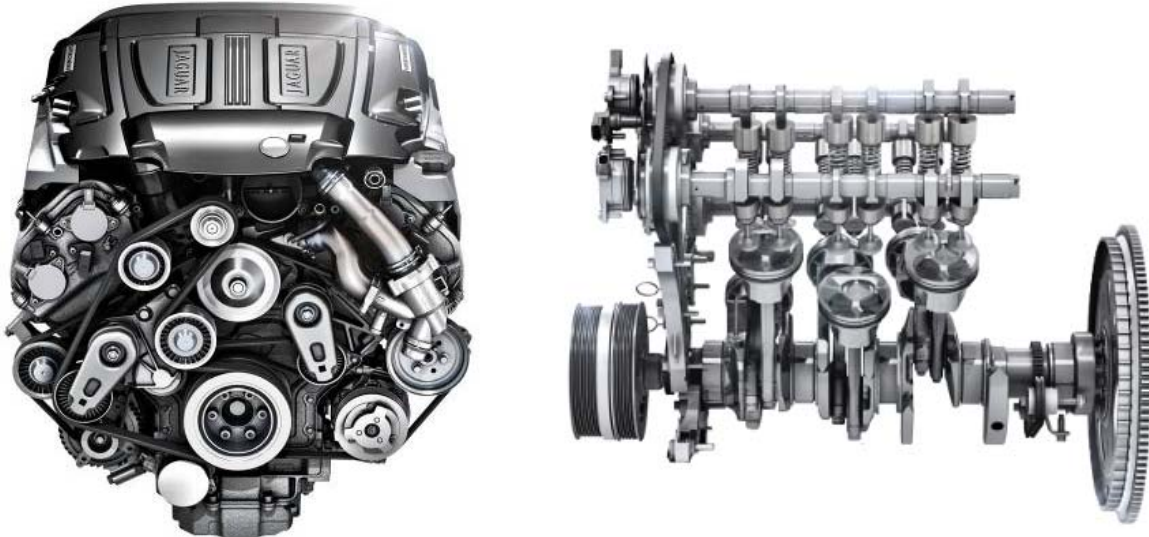

At launch, a new 3.0L V6 Supercharged engine is available on the standard wheel base XJ, raising to 4 the number of engines available on the car line (see section #4 - Product Line-up change summary - for engines detailed application). This engine is based on the architecture of the acclaimed Jaguar V8 engines, providing a refined and smooth power delivery and includes the following specifications:

- Roots twin-vortex supercharger design: provides instant torque response and greater efficiency. Water cooled intercooler reduces intake air temperature optimizing power & efficiency.
- Variable Camshaft Timing: Twin variable valve timing with intake and exhaust valve timing independently controlled, optimizing power, torque and economy at all engine speeds.
- Direct Injection: High-pressure (150bar) direct fuel injection system ensures precise fuel delivery for cleaner, more efficient combustion. Enhanced droplet control and vaporization creates a homogeneous mixture greatly improving combustion. Charge cooling effect results in higher volumetric efficiency and knock limit improvement.
- Orientated Spark Plugs: spark plug orientation aligns the spark plug electrode with the direct fuel injection system, improving combustion robustness (misfire free) and minimizing spray impingement onto spark plug giving improvements in spark plug electrode cooling. Spark plug orientation control provides improved idle stability, dilution tolerance and spark plug durability.
- New Balancer Gear : the engineering balance target of 75gcm within the V8 90deg bank angle required an innovative solution resulting in a pair of independently aligned counter rotating balance weights at both ends of the crankshaft

## 1.2 New 8-speed automatic Transmission

All XJ engines are fitted with the ZF (8HP70) 8-speed automatic gearbox including lightweight rear differential with aluminum casing and improved bearings. It offers the following improvements over the previous 6-speed unit:

- Larger overall ratio and more even gear spacing providing an improved fuel economy at high speed and smoother acceleration.
- Quicker shift timing – Gear shifts are initiated in just 200 milliseconds.
- Multiple downshifts are enabled meaning direct downshifts are possible rather than sequential shifting.
- Improved efficiency – Energy losses are kept to a minimum through the use of an improved pump design and improved control of gear elements at idle and in drive, helping to further improve fuel economy.
- Weight control – Use of lightweight components has enabled the overall weight and dimensions of the gearbox to remain the same despite the extra gears and enhanced torque capability.
- The transmission is operated in the same way as the previous 6-speed unit and continues to offer 'Sport' and 'Dynamic' mode allowing for manual gear shifts via the paddle shift. (see further information in the feature change section regarding paddle shift functionality in "D" and "S" mode)

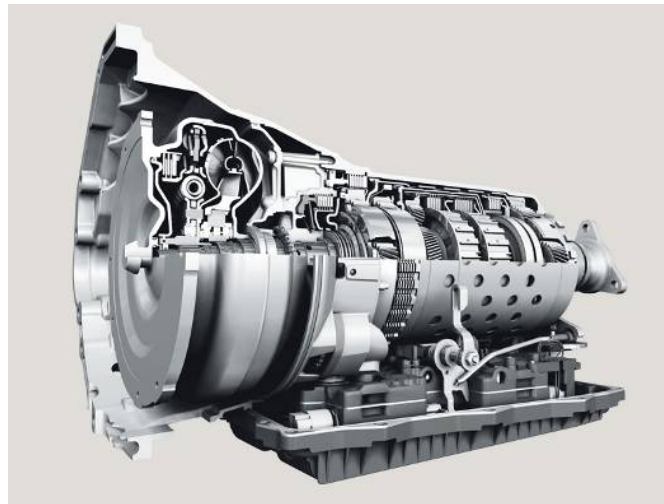

## 1.3 Intelligent Stop/Start

### 1.3.1. System Description

Intelligent Stop/Start is part of the Jaguar Land Rover sustainability strategy. The system detects when it is appropriate to shut down the engine – known as 'Eco Stop' - hence the 'intelligence' of the system. When the driver releases the brake pedal the engine re-starts almost instantaneously and the vehicle is ready to 'creep' or accelerate (Eco Start). The system is fully integrated with the vehicle architecture and specific vehicle systems can establish whether or not to allow an Eco Stop and can request an Eco Start.

- The Jaguar Intelligent Stop/Start system incorporates a TSS (Tandem Solenoid Starter) to achieve the Stop/Start functionality. A TSS system comprises an upgraded starter motor with tandem solenoids to achieve instant re-starts, regardless of the current status of the engine (engine stopped or on run down). This is known as 'change of mind' functionality which removes any hesitation in re-start, a problem which can afflict our competition.
- An advantage of the TSS system and its 'change of mind' feature is the speed of engine re-start - even if the engine is on rundown (i.e. if the engine has only just / has not yet stopped). The engine will re-start quicker than the time taken for the customer's foot to come off the brake pedal and press the accelerator pedal.
- A secondary battery is fitted specifically for engine re-starting, meaning that all the normal car systems (radio, ventilation, lights, etc.) continue to receive power from the standard car battery and are unaffected by the re-start. In addition, a complex control system ensures that the Stop/Start operation only occurs when the car does not require the engine for other functions.

### 1.3.2 Intelligent Stop/Start Operation Criteria

There are a number of factors affecting whether or not Intelligent Stop/Start will function. Here are a few common factors whereby the system will not initiate an Eco Stop:

- *Ambient temperature:* For driver comfort, Stop/Start only operates between 32°F and 104°F.
- *Engine temperature:* If the engine is very cold, Stop/Start will not operate. The engine needs to be at the correct operational temperature for Stop/Start to function.
- *Cabin ambient temperature:* The climate control system constantly monitors the cabin conditions and determines whether the engine is required to maintain customer comfort. For example, if 'Max Defrost' is selected, Stop/Start will not operate.
- *Vehicle is already moving or starts to move:* The vehicle needs to be stationary for the Stop/Start system to operate. If the vehicle starts to move (>0.62mph) the engine will re-start.
- *Seatbelt latching:* If the vehicle is stationary, the Stop/Start system will perform an 'Eco Stop' as soon as the driver unlatches the seatbelt and exits the vehicle, or as soon as the hood is opened. This is a unique feature of the system.
- *Vehicle power requirements:* Conversely, the engine will perform an 'Eco Start' if the vehicle detects it requires additional power to fulfill its function.

### 1.3.3 Driver Controls and Instrument Tell Tale for Intelligent Stop/Start

The default setting for Intelligent Stop/Start is 'on'. With every ignition cycle, Intelligent Stop/Start will be turned on automatically. Intelligent Stop/Start can be turned off manually via a hard button located below the touch screen but it will be turned on again for the vehicle's next journey. Stop/Start operates in all modes apart from Reverse.

An illuminated 'ECO' symbol appears on the Instrument Panel when the engine has been stopped by the system. The engine re-starts as soon as the driver's foot releases all pressure from the brake pedal.



From XF Instrument cluster



### 1.4 Paddle Shift Functionality

At 2012MY, manual shifting can only be completed when sport "S" mode is engaged on vehicles fitted with naturally aspirated engines only. Recognizing that some drivers do want the ability to manually shift gear in Drive "D" mode while others are inconvenienced by the paddles position and the potential for inadvertently hitting the shift paddles and selecting manual mode, at 13MY the paddle are now adjustable via the "Vehicle set up" in the instrument cluster.

The vehicle default delivery setting is based on engine fitment

- V6 Supercharged – paddles are not active in "D" mode
- V8 Naturally aspirated – paddles are not active in "D" mode
- V8 Supercharged 470hp and 510hp – paddles are active in both "D" and "S" modes

To change the setting:

- Press the "Menu/OK" button on the vehicle steering wheel to display the list of options
- Select the "Vehicle Set-up" option and open the sub menu
- Select the "Gearbox Paddles" option and again open the sub-menu
- Setting of "Active in S only" or "Active in D & S" will be identified and can be changed as desired by the driver.



## 2 - FEATURE CHANGES

### 2.1 Exterior Changes

A new exterior badging strategy is introduced on XJ:

- New "JAGUAR" script on the center trunk lid below the leaper, helping to reinforce the brand recognition of the vehicle
- "3.0" or "5.0" engine displacement badge on the right hand side of the trunk
- "Supercharged", "Supersport" or "Ultimate" script is retained on the side power vents, however the "portfolio" script is discontinued



At 13MY, all XJ are fitted with a roof antenna pod similar to the XF.



*Changes in standard equipment, options or prices can occur. Jaguar reserves the right to change product specifications at any time without incurring obligations.*

## 2.2 Interior Changes

- At 13MY, the standard seats movements on all XJ derivatives except for XJ /XJL Supersport are being amended. The XJ swb is fitted with 12x12 heated front seats while front seats massage becomes an option on XJL and XJ/XJL Supercharged. See table below summarizing the changes from 12MY to 13MY.

### Seat Configuration Change 2012 to 2013 Model Year

	XJ SWB				XJL Portfolio XJL Supercharged		XJ/XJL Supersport	
	12MY		13MY		12MY	13MY	12MY	13MY
Standard Seat Fitment	Driver	Pass	Driver	Pass	D&P	D&P	D&P	D&P
Fore / Aft	✓	✓	✓	✓	✓	✓	✓	✓
Cushion Height	✓	✓	✓	✓	✓	✓	✓	✓
Squab recline	✓	✓	✓	✓	✓	✓	✓	✓
Cushion tilt	✓	✓	✓	✓	✓	✓	✓	✓
4 way lumbar	✓	✓	✓	✓	✓	✓	✓	✓
Powered headrest	✓				✓	✓	✓	✓
Cushion extension	✓				✓	✓	✓	✓
Adjustable bolsters					✓	✓	✓	✓
Massage					✓		✓	✓
Total "Ways"	16	12	12	12	20/20	18	20/20	20
<b>Other features</b>								
Seat Material	Softgrain		Softgrain		Softgrain	Softgrain	Semi aniline	Semi aniline
IP, door panels & upper fascia	Softgrain		Softgrain		Softgrain	Softgrain	Semi aniline	Semi aniline
Headliner	Morzine		Morzine		Suedecloth	Suedecloth	Leather	Leather
Heated	✓	✓	✓	✓	✓	✓	✓	✓
Cooled	✓	✓			✓	✓	✓	✓
Memory	✓		✓		✓	✓	✓	✓
<b>Front Seat Massage Option</b>						<b>Opt</b>		
Front Massage						✓		
Total "Ways" with option						20		
<b>Front Seat comfort Pack</b>			<b>Pck</b>	<b>Pck</b>				
Powered headrest			✓	✓				
Cushion extension			✓	✓				
Adjustable bolsters (2W)			✓	✓				
Front Seat Massage			✓	✓				
Cooled Front Seats			✓	✓				
Total "Ways" with Pack			20	20				
<b>Portfolio Pack (swb)</b>	<b>O</b>		<b>Pck</b>	<b>Pck</b>				

- New rear seat pack

The rear seat comfort pack that was launched as standard equipment on the XJL Supersport at 12MY is now available on all LWB derivatives, in combination with the executive pack on the XJL and as a separate package on XJL Supercharged.

XJL Rear Seat Comfort Pack	XJL Supercharged Rear Seat Comfort Pack
<ul style="list-style-type: none"> <li>• Rear seat power recline (outboard seats recline independently )</li> <li>• Rear seat 4-way lumbar</li> <li>• Rear seat massage</li> <li>• Rear seat footrest</li> <li>• Winged headrest on both front and rear seats</li> <li>• Front passenger seat away*</li> <li>• Rear business Tray</li> <li>• Electric rear window sunblind</li> <li>• Premium front and rear floor mats</li> <li>• Intaglio with Union Jack and "Jaguar" script</li> <li>• Chrome side mirror covers</li> </ul>	<ul style="list-style-type: none"> <li>• Rear seat power recline (outboard seats recline independently )</li> <li>• Rear seat 4-way lumbar</li> <li>• Rear seat massage</li> <li>• Rear seat footrest</li> <li>• Winged headrest on both front and rear seats</li> <li>• Front passenger seat away*</li> </ul>

\* The front passenger seat can be adjusted forward, via control accessible by both the driver and the rear right hand passenger, to allow for increase rear seat legroom for the rear passenger-side occupant.

- A new compact key originally scheduled to launch at 12MY is planned for 13MY introduction



### 2.3 Infotainment - Meridian™ Audio System

Meridian™ Audio is an ultra-premium British audio specialist widely regarded as the audiophiles' choice offering a multi award-winning range of audio equipment globally. For 13MY, new Meridian™ audio systems will be standard on all XJ

#### 2.3.1 Meridian™ Audio Unique Design and Technology

- Total system optimization
  - Speakers and amplifiers are perfectly matched to optimize efficiency and sound quality. This achieves better audio quality with lower power requirement than conventional systems.
- Highest sound quality
  - Other manufacturers compare the sound of their systems to others in their class. Meridian™ use real instruments such as a Steinway Piano or the human voice as their benchmark. The result is that Meridian™ speakers are truer to the original sound.
- Psychoacoustics
  - Meridian™ engineers have utilized research into psychoacoustics to produce sounds that are so true to life that they are perceived by the brain as the real thing giving listener greater connection with the sound inside the car.

*Changes in standard equipment, options or prices can occur. Jaguar reserves the right to change product specifications at any time without incurring obligations.*



### 2.3.2 Meridian™ Audio features

- Digital Signal Process (DSP) software – All elements of the system are optimized
- Dynamic Volume Control – Uses a front-mounted microphone to detect variations in cabin noise and compensates for changes in ambient sound levels to provide consistent sound quality.
- Meridian™ Cabin Correction
  - Employs advanced DSP to complement the acoustics of the vehicle, improving clarity and authenticity of sound
  - Meridian™ Audio's room correction algorithms have been incorporated to overcome problem of acoustic resonances within the cabin.
  - Digital filtering technology is used to 'smooth' these resonances ensuring that the crucial pitch and timing of transient details is accurately reproduced.
- Meridian™ Digital Dither Shaping – Digital signal conversions and processes are executed accurately and smoothly throughout the system, maintaining maximum detail ensuring highest quality from all sources.
- Meridian™ Trifield System – Delivers a perfect stereo sound to all occupants in the vehicle. It enhances the performance of stereo material by using three front channels to increase localization accuracy and rendering a more stable, natural soundstage.

### 2.3.3 Audio System Power Output

Traditionally, the performance of automotive audio systems has been measured in terms of power output in Watts. Meridian™ adopts a different view, designing the speakers to work harmoniously with the amplifier as an integrated, active audio system. This approach provides a superior system without requiring the high power required by many audio systems.

Total Harmonic Distortion (THD) of an audio signal is a measure of the harmonic distortion. Harmonic Distortion occurs when a signal is “clipped” or altered due to a part of the sound system not being capable of reproducing the signal. If the system runs out of headroom the signal distorts, producing undesirable sound due to limitations in the amplifier design. A lower level of THD will allow the components in a loudspeaker & amplifier to produce a more accurate audio reproduction by reducing the distortion added by electronics and audio media. A THD rating less than 1% is considered to be high-fidelity and inaudible to the human ear. The audio systems used before 13MY have a THD of 10% where the new Meridian™ audio systems have a THD of only 0.2%. This reduction in harmonic distortion means a lower power output is required to achieve the high levels of audio clarity within the vehicle.

### 2.3.4 Two levels of Meridian™ audio system are available on the XJ

Meridian™ Premium Audio System	Meridian™ Premium 7.1 Surround Audio System
<ul style="list-style-type: none"> <li>• 380W premium Sound System</li> <li>• 12 Amplifier Channels</li> <li>• 12 Speakers + 2 subwoofers</li> <li>• Separate DSP</li> <li>• Audyssey MultEQ sound equalization</li> <li>• Meridian™ Cabin noise correction</li> <li>• Dynamic volume control</li> </ul> <p>Standard on: XJ and XJL Portfolio</p>	<ul style="list-style-type: none"> <li>• 825W premium Sound System</li> <li>• 15 amplifier Channels</li> <li>• 18 Speakers + 2 subwoofers</li> <li>• Separate DSP</li> <li>• Audyssey MultEQ sound equalization</li> <li>• Meridian™ Cabin noise correction</li> <li>• Dynamic volume control</li> <li>• Meridian™ Trifield System</li> </ul> <p>Standard on: XJ/XJL Supercharged XJ/XJL Supersport XJL Ultimate</p> <p>Optional on: XJ &amp; XJL Portfolio</p>

*Changes in standard equipment, options or prices can occur. Jaguar reserves the right to change product specifications at any time without incurring obligations.*

### 3. PRODUCT LINE UP CHANGE SUMMARY

#### TWO WHEELBASES, FOUR TRIM LEVELS AND FOUR ENGINES

The XJ Continues to be offered in both standard and long wheel base variants.

Four trim levels are available:

- Base trim – offers soft grain leather seats with heated front and rear seats.
- "Portfolio" trim – adds contrast stitching and piping, embossed headrests, soft grain leather door panels, instrument panel and fascia, suedecloth headlining, 18/18 way adjustable front seats, cooled front and rear seats and 4-zone climate control
- "Supersport" trim – adds semi aniline leather seats, soft grain leather headliner, lighted air vents and door/trunk sills and offers inlaid wood veneers and tipped leather options
- "Ultimate" trim – Adds full partition leather trimmed rear center console, powered passenger table, integrated illuminated beverage chiller, seat back iPad® docks with sliding door and charging capability and unique trim color, veneer and exterior color. For further details on this exclusive trim, please see the Product Brief issued on April 22, 2012

Engine applications:

- At launch the standard wheel base variants are available with the new Supercharged V6, the Supercharged V8 470hp or the Supercharged V8 510hp. The V8 Naturally aspirated engine is no longer available on standard wheel base XJ.
- Identical to 12MY, the long wheel base variants are available with the V8 Naturally aspirated 385hp, the Supercharged V8 SC 470hp or the Supercharged V8 510hp.

Standard Wheel Base	Engine	Trim Level	Memo: 12MY Engine fitment	Long Wheel Base	Engine	Trim Level	Memo: 12MY Engine fitment
XJ	V6 SC 340hp	Base trim	V8 NA 385hp	XJL Portfolio	V8 NA 385hp	Portfolio	c/o
XJ Supercharged	V8 SC 470hp	Portfolio	c/o	XJL Supercharged	V8 SC 470hp	Portfolio	c/o
XJ Supersport	V8 SC 510hp	Supersport	c/o	XJL Supersport	V8 SC 510hp	Supersport	c/o
				XJL Ultimate	V8 SC 510hp	Ultimate	n/a

## 4. COLOR, TRIM & VENEERS

For 2013 Model Year, the Special Order (SO) charge has been eliminated. We are still publishing Designer's choice recommendations to provide you guidance on preferred combinations; however **deviation from these recommendations will no longer carry a charge**. The Racing Paints still carry an extra charge







The exterior paint palette receives a minor update with the introduction of 2 new colors

- **Carnelian Red** – replaces Claret from Job#1
- **Satellite Grey** – introduced at 13.5MY. First order call for Satellite is expected to be November 2012







A new **Gloss Shadow Walnut** veneer will be available as a no charge option on XJ /XJL Supersport models. (See veneer fitment detail below for image.)

Veneer Fitment - All models except XJ/XJL Supersport & XJL Ultimate

Veneer	Image	Fitment and Availability	Available with Wood Steering Wheel
Burl Walnut		XJ (standard) XJL Portfolio XJ/XJL Supercharged	Yes
Satin Elm		XJ XJL Portfolio XJ/XJL Supercharged	
Figured Ebony		XJ w/ Port Pk (standard) XJL Portfolio (standard) XJ/XJL Supercharged	Yes
Rich Oak		XJ/XJL Supercharged	Yes
Piano Black		All	
Carbon Fiber		Optional on all (\$1,500)	

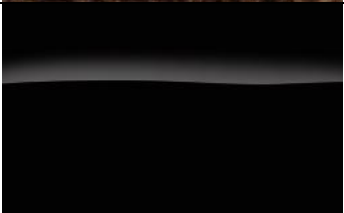
Changes in standard equipment, options or prices can occur. Jaguar reserves the right to change product specifications at any time without incurring obligations.

Veneer Fitment -XJ/XJL Supersport

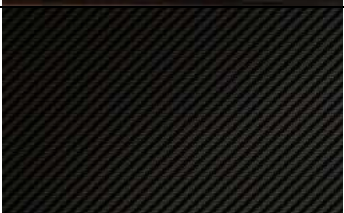





Supersport Veneers	Image	Fitment and Availability	Available with Wood Steering Wheel
Walnut Curl		Supersport	Yes
Piano Black		All	
Satin Zebrano		Supersport	
Shadow Walnut New for 13MY		Supersport	Yes
Rich Oak with Linear Laser Inlays		Supersport (standard)	Yes
Figured Ebony with Ribbon Laser Inlays		Supersport	Yes
Carbon Fiber		Supersport (no cost option)	

**XJ Ultimate** – Unique Herringbone Veneer Standard – See separate Product Brief

*Changes in standard equipment, options or prices can occur. Jaguar reserves the right to change product specifications at any time without incurring obligations.*

## 5. WHEELS

- The 20" Amirante wheel style is no longer available at 13 Model Year
- Naturally aspirated models (XJ and XJL) come standard with **19" wheels** with all-season tires; a selection of 20" wheels on summer/performance tires are available as options. These models, regardless of wheel/tire, have a top speed limited to 121mph
- Supercharged and Supersport models come **standard with 20" wheels** with summer/performance tires; these models have a top speed limited to 155mph; **19" wheels** with all-season tires are an **option** on Supercharged and Supersport models – when equipped with 19" wheels these models have a top speed limited to 121mph

Size / Style / Finish	Image	Fitment and Availability
<b>19" Aleutian</b>  Finish: - Sparkle Silver		Standard on: XJ  Optional on: all
<b>19" Toba</b>  Finishes: - Sparkle Silver - Polished		Standard on: XJL Portfolio (Sparkle Silver)  Optional on: all
<b>20" Kasuga</b>  Finishes: - High Gloss Silver - Polished		Standard on: XJ & XJL Supercharged (High gloss Silver)  Optional on: all
<b>20" Mataiva</b>  Finish: - Anthracite with chrome detailing		Standard on: XJ & XJL Supersport  Optional on: None - Supersport only
<b>20" Orona</b>  Finishes: - Anthracite with diamond turned spokes - Polished		Standard on: None - option only  Optional on: all
<b>20" Venom</b>  Finish: - Painted with Diamond turned spokes		Standard on: Sport & Speed/Speed Pack  Optional on: None – Sport & Speed/Speed pack only

## 6. RESOURCES

### **Order Guide**

For additional reference – including technical specs, the full list of standard and optional equipment, color & trim chart and wheels – see the separate **2013 MY XJ Order Guide**, available on the Product & Distribution website: <https://jaguarvehicles.jlrext.com/newxj/index.html>

### **Online Car Configurator**

To visually see and build the various color and trim combinations of XJ available visit the online Car Configurator on the JaguarUSA.com website, which will be updated in August with 2013MY: [http://www.jaguar.com/us/en/#/build\\_your\\_jaguar](http://www.jaguar.com/us/en/#/build_your_jaguar)

If you have any additional product questions please contact your Market Manager or me.