

phow93-70016-a-a3

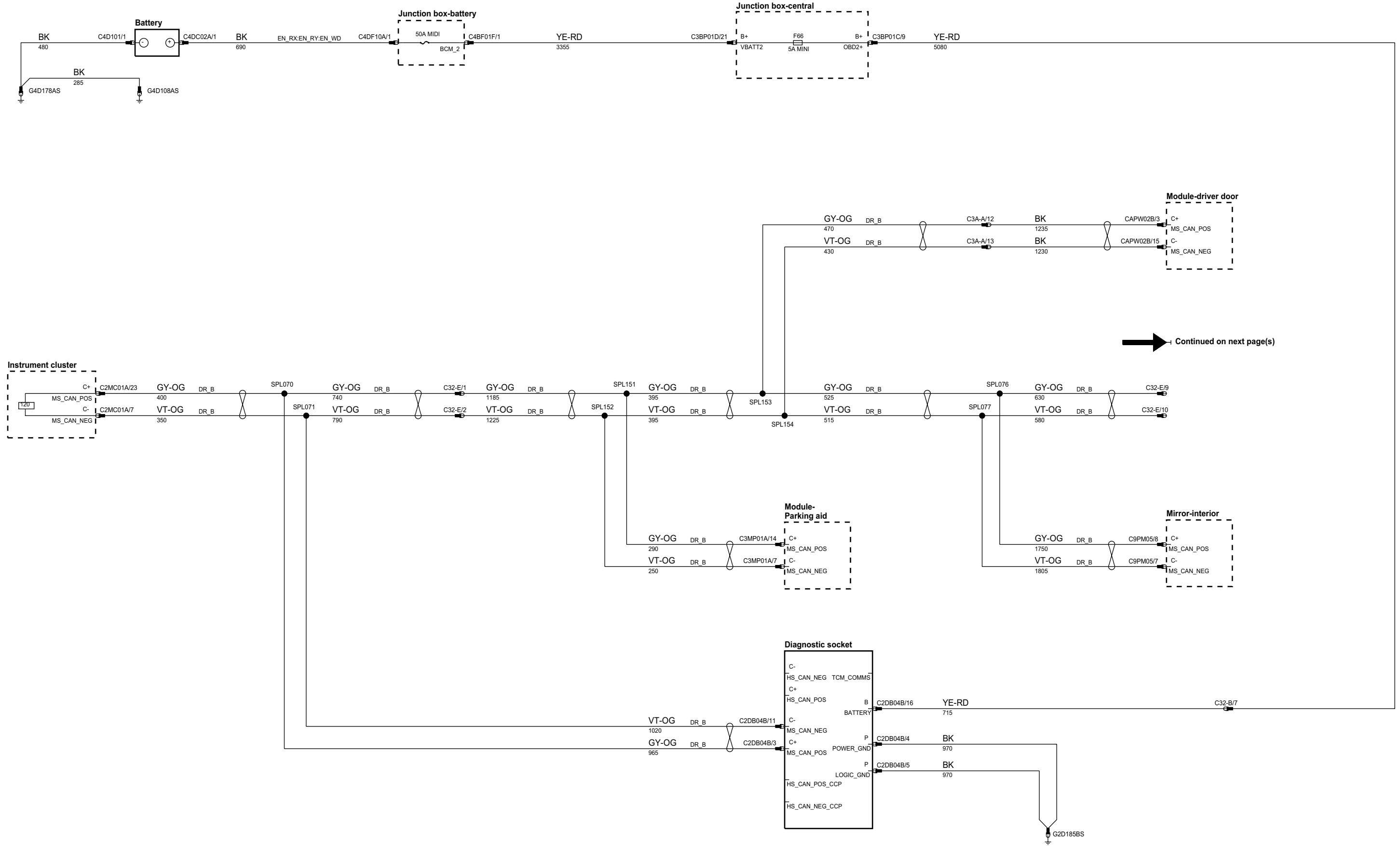

phcw93-70016-b-a3

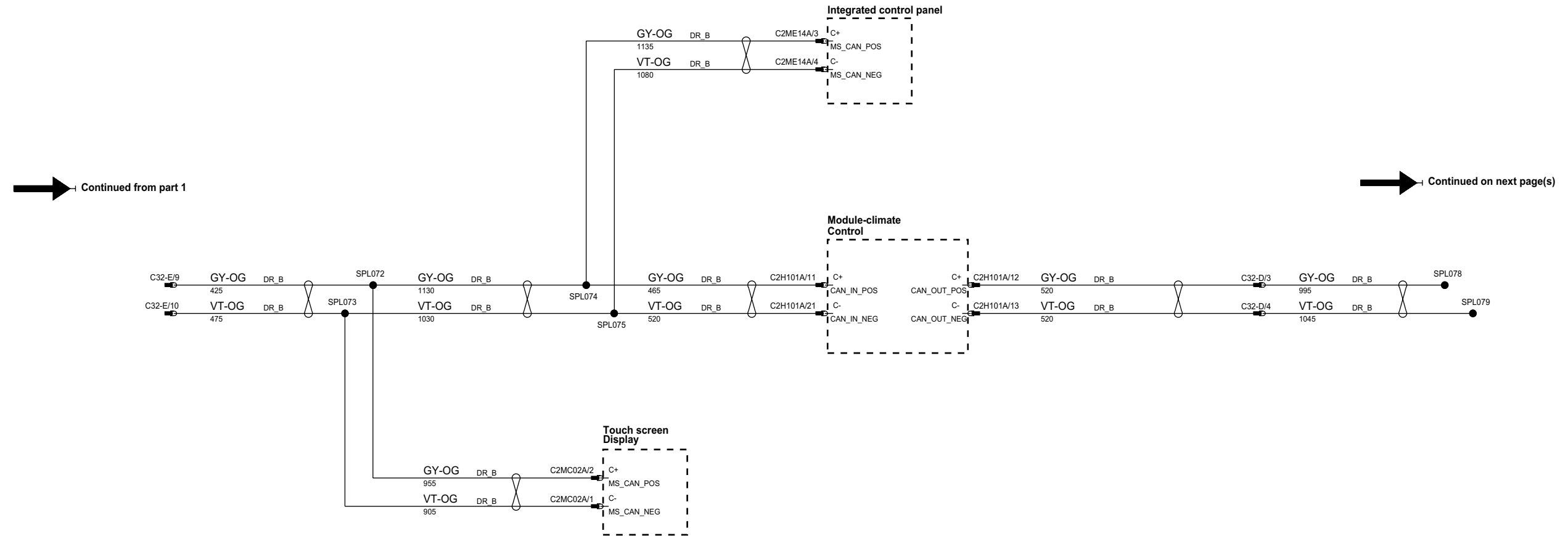

Continued from part 1

Continued on next page(s)

phcw93-70016-c-a3

Continued from previous page

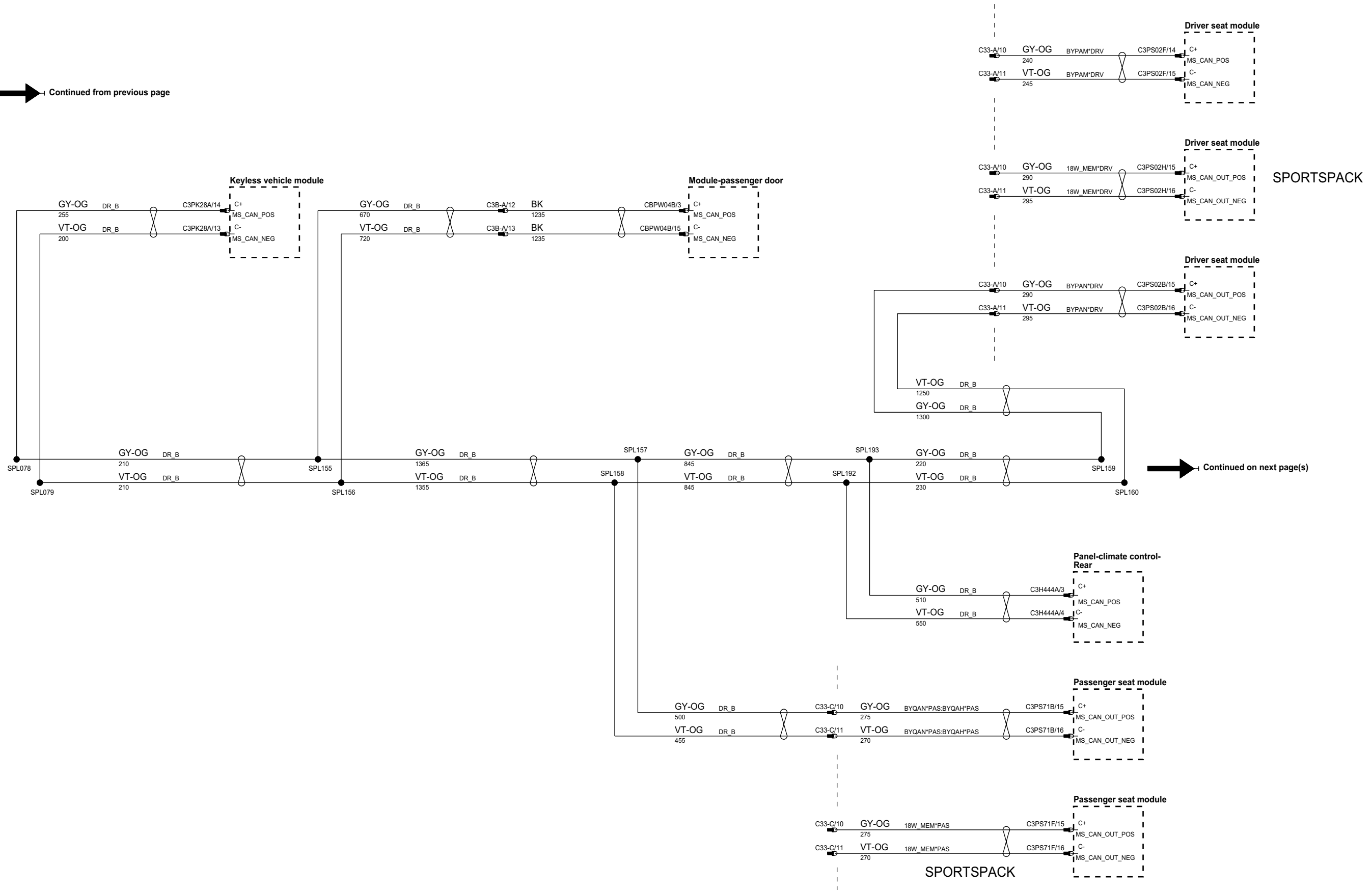

Continued on next page(s)

phcw93-70016-d-a3

Continued from previous page

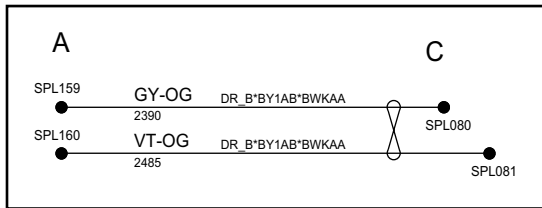
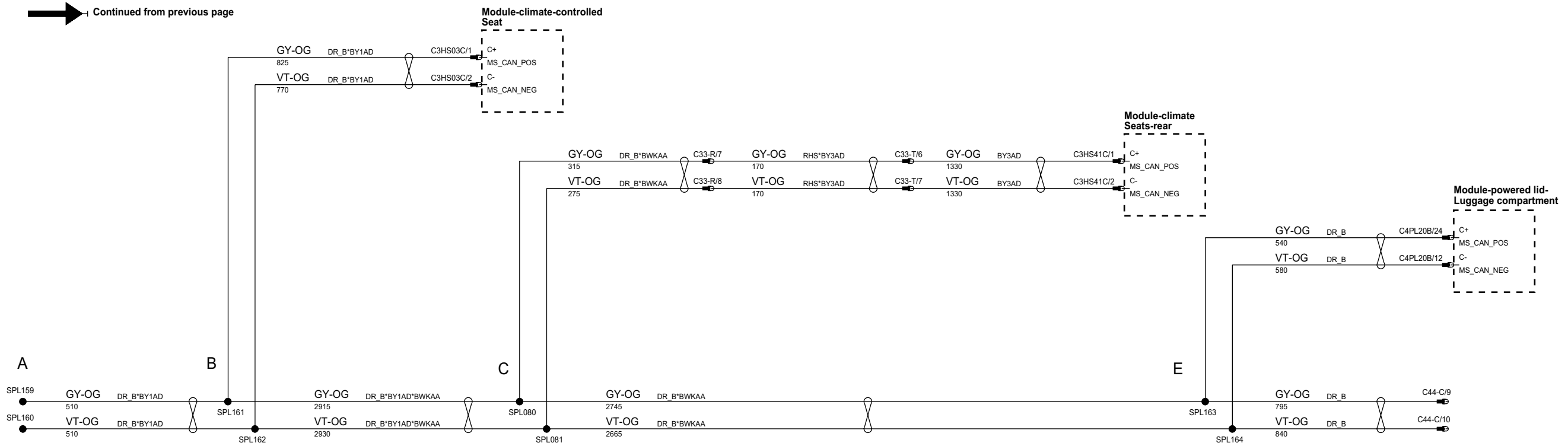

Continued on next page(s)

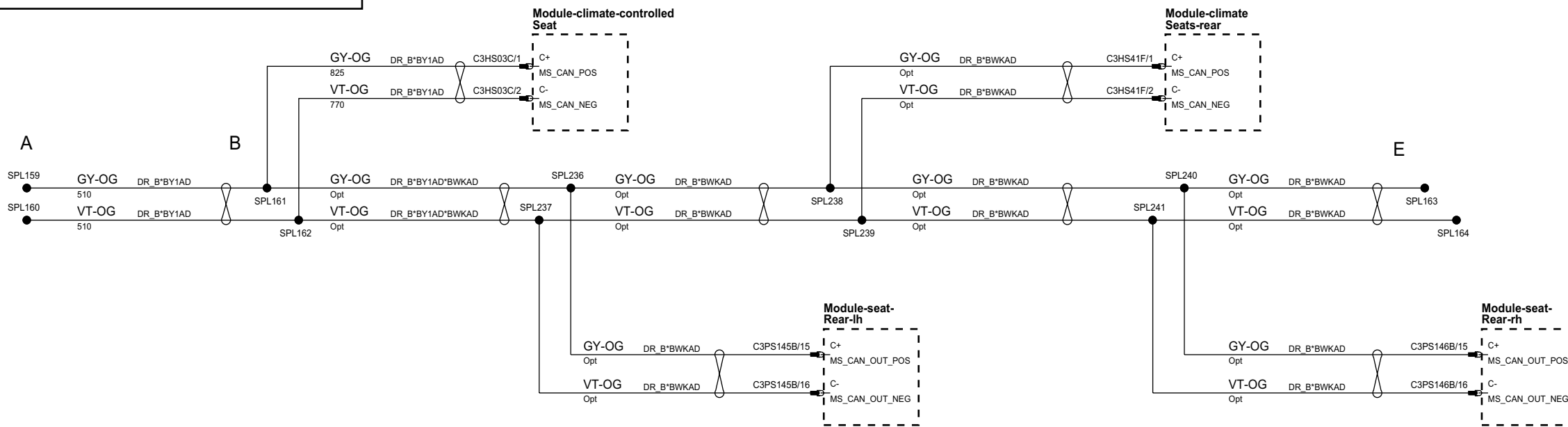

phcw93-70016-v-a3

Continued from previous page

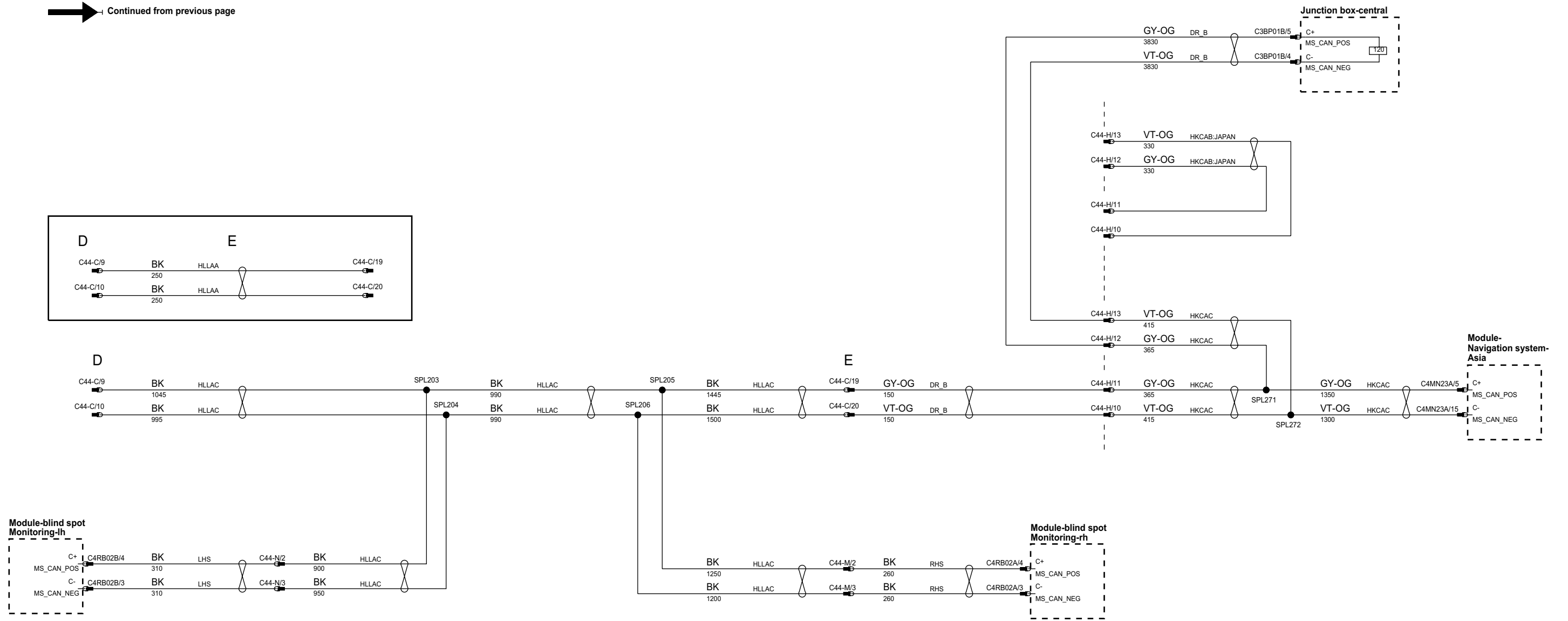

phcw93-70016-e-a3

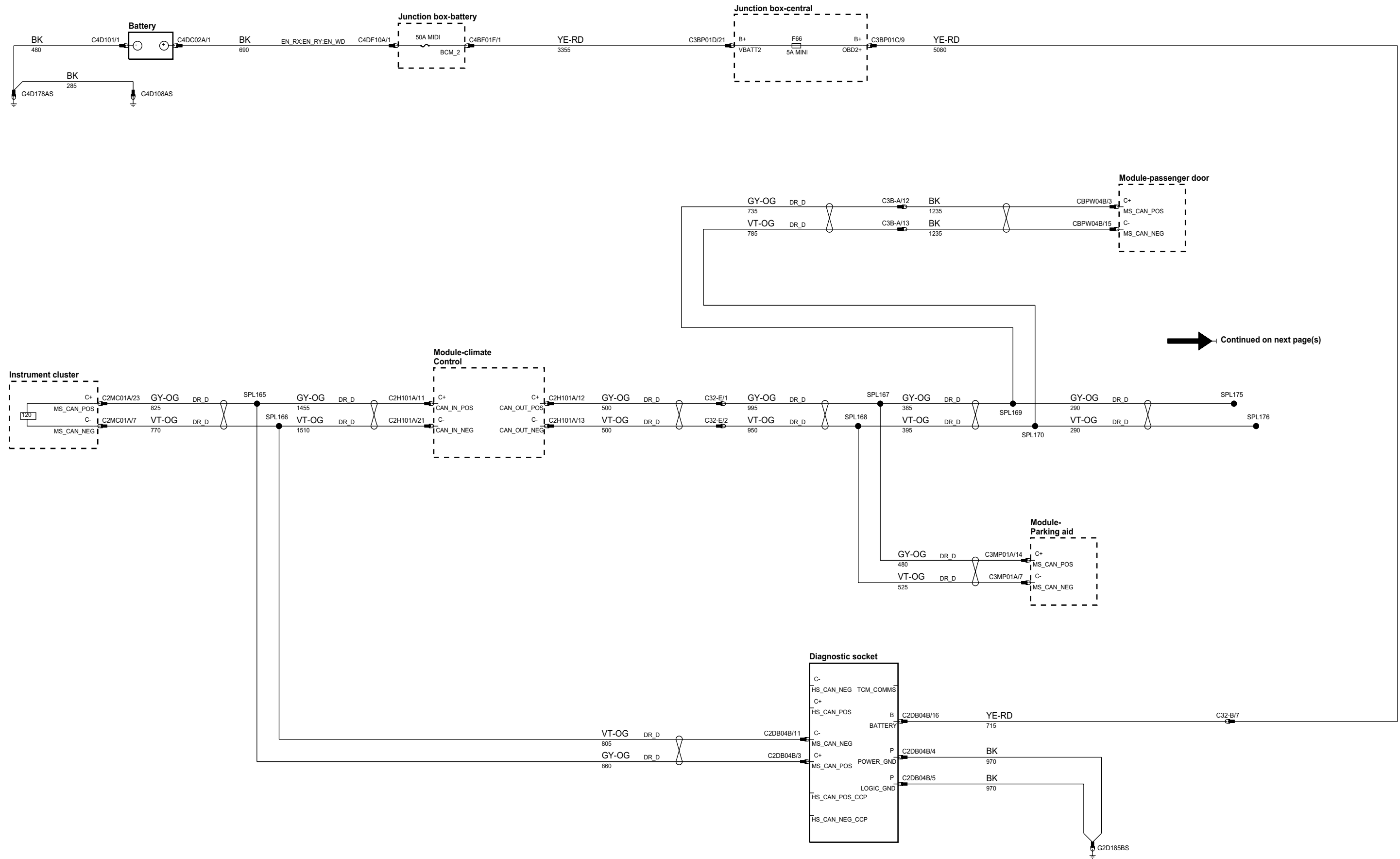

Continued on next page(s)

phcw93-70016-f-a3

Continued from previous page

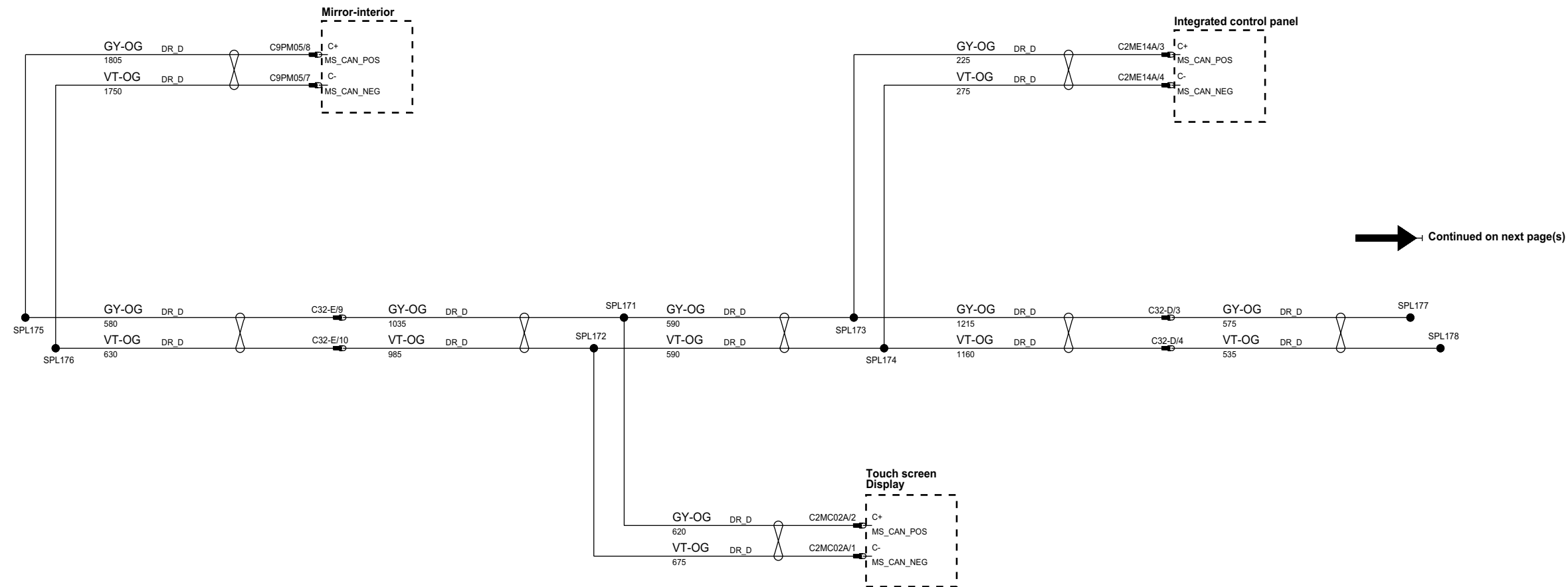

Continued on next page(s)

pinw93-1/0010-g-03

Continued from previous page

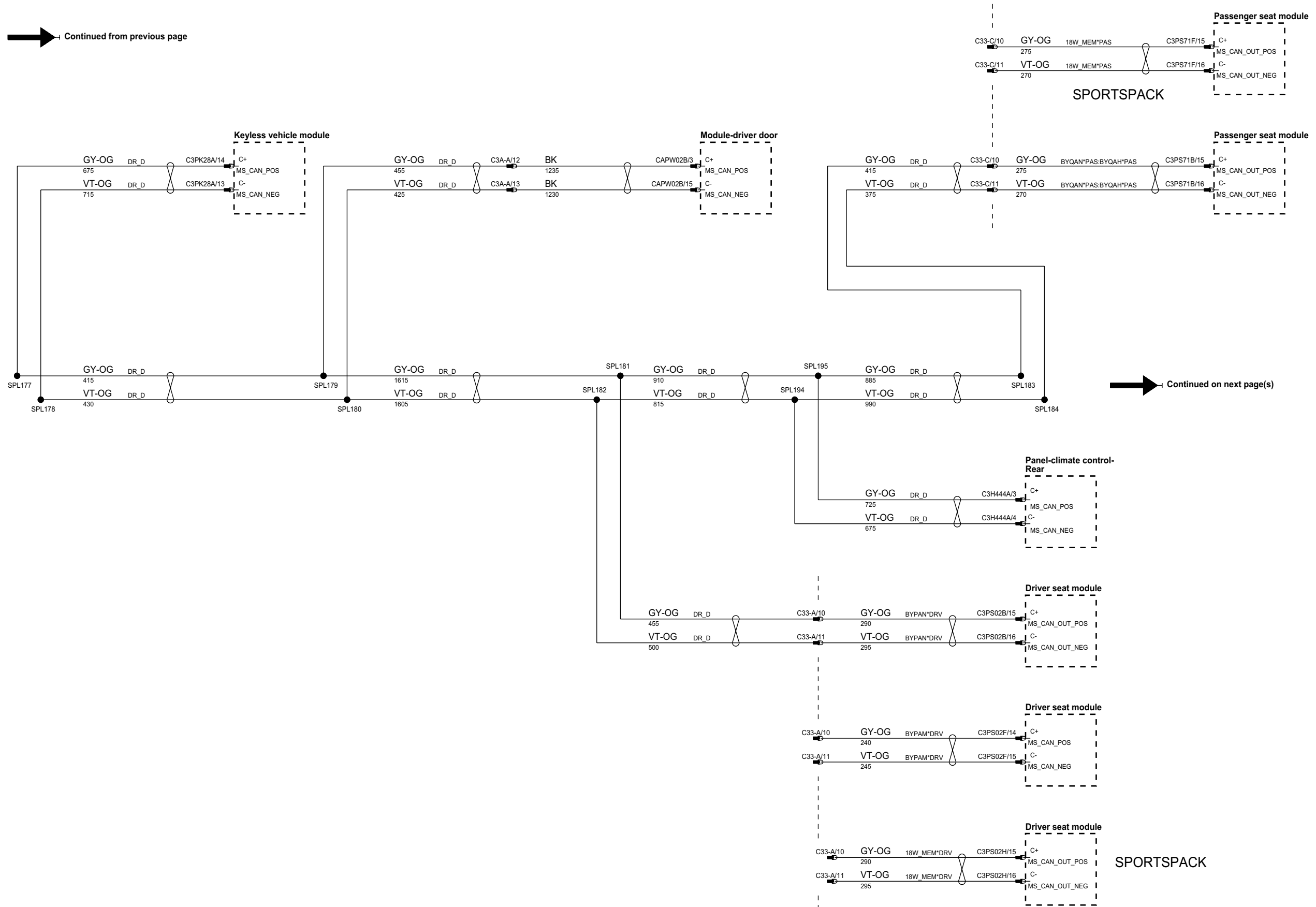

Continued on next page(s)

phcw93-70016-u-a3

Continued from previous page

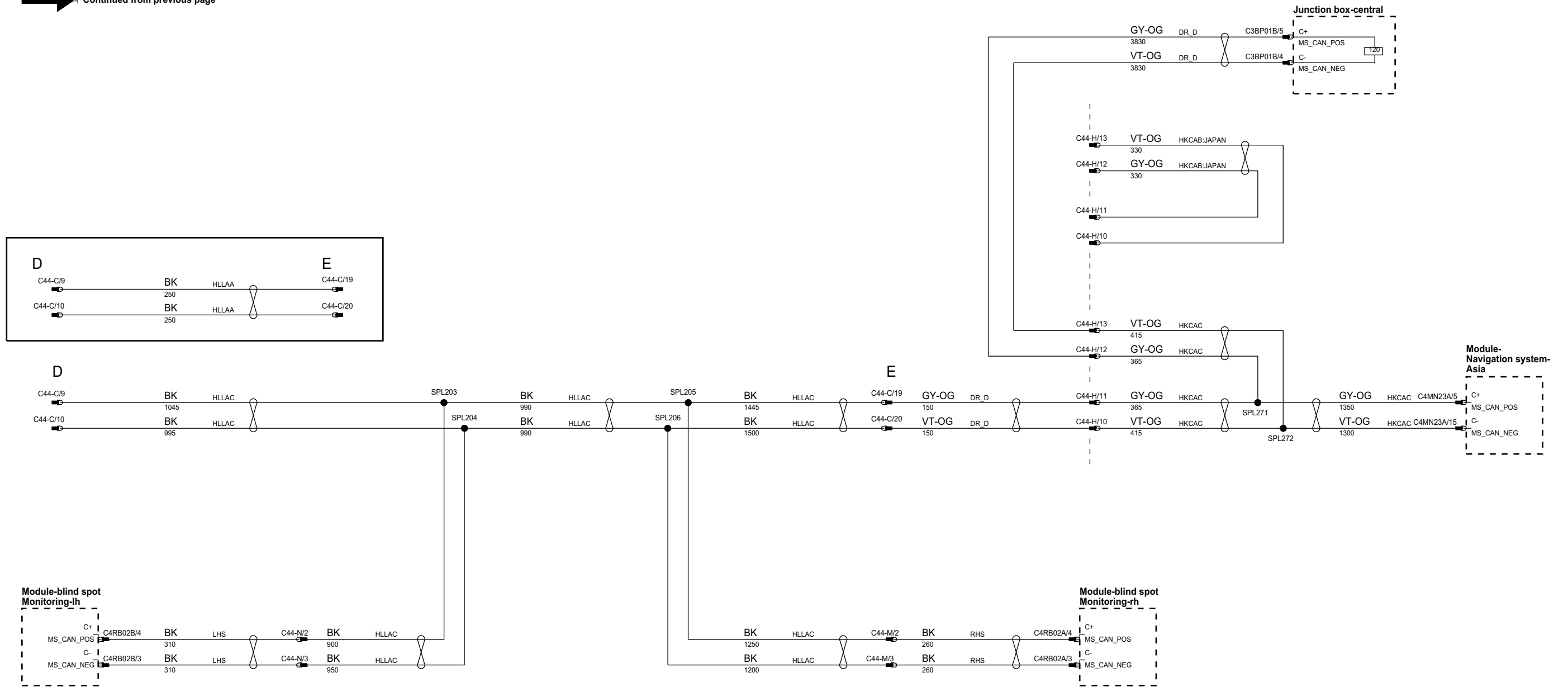

phcw93-70016-j-a3

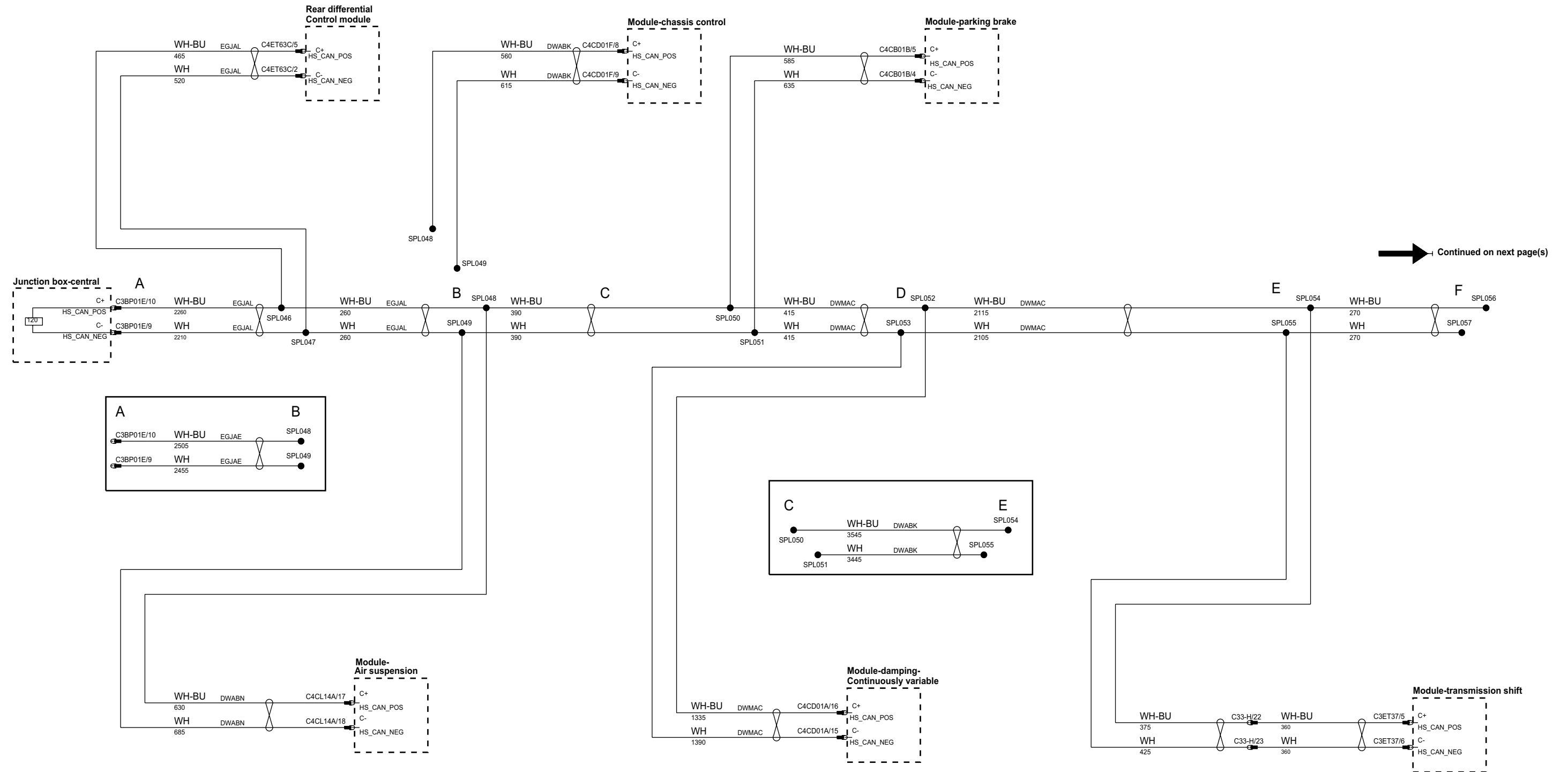

phcw93-70016-k-a3

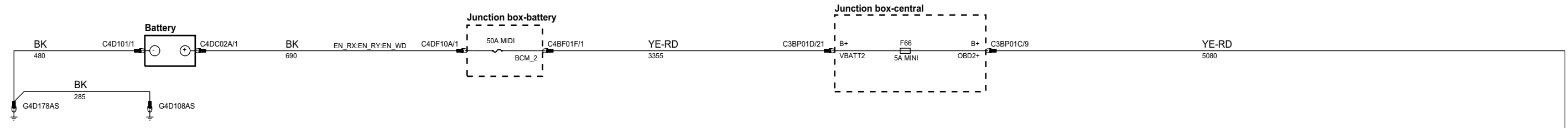

Continued from previous page

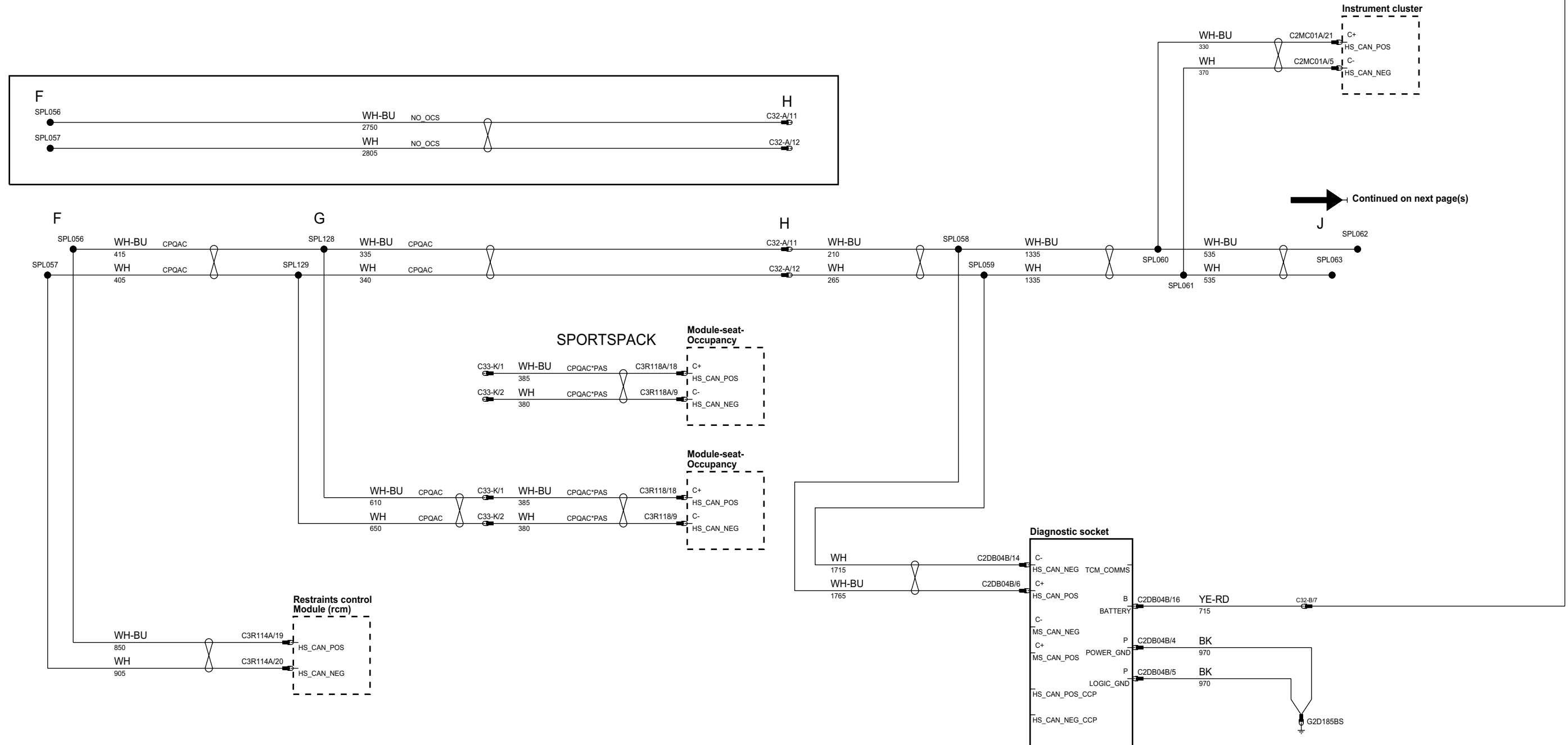

Continued on next page(s)

phcw93-70016+a3

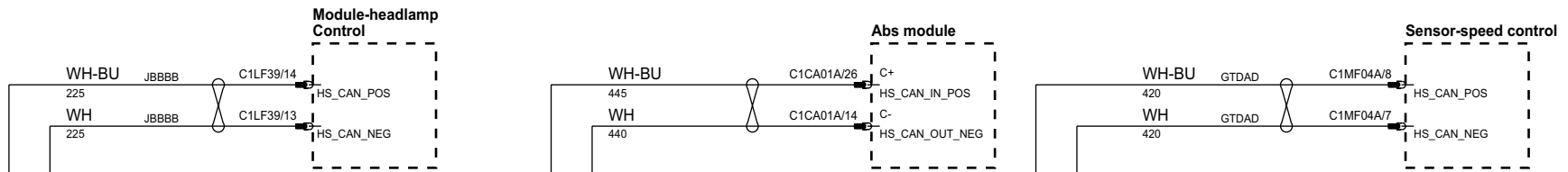
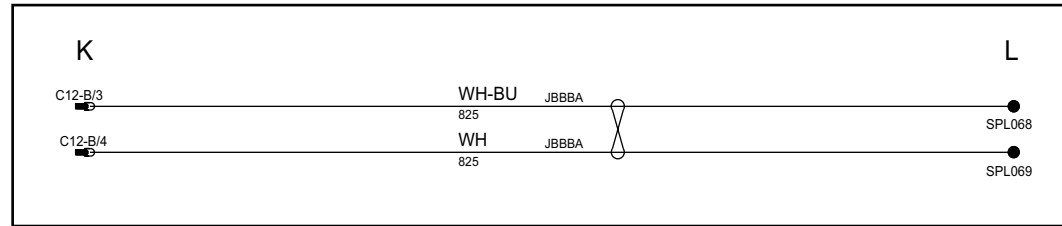

Continued from previous page

Continued on next page(s)

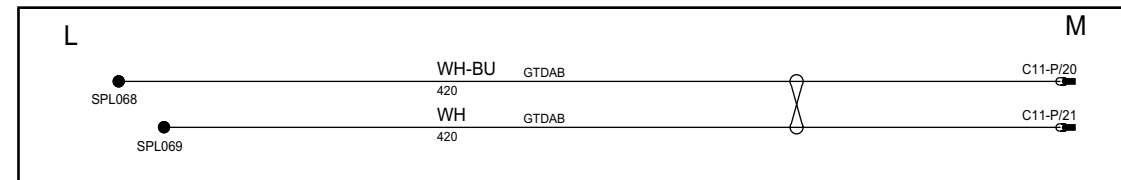

phcw93-70016-m-a3

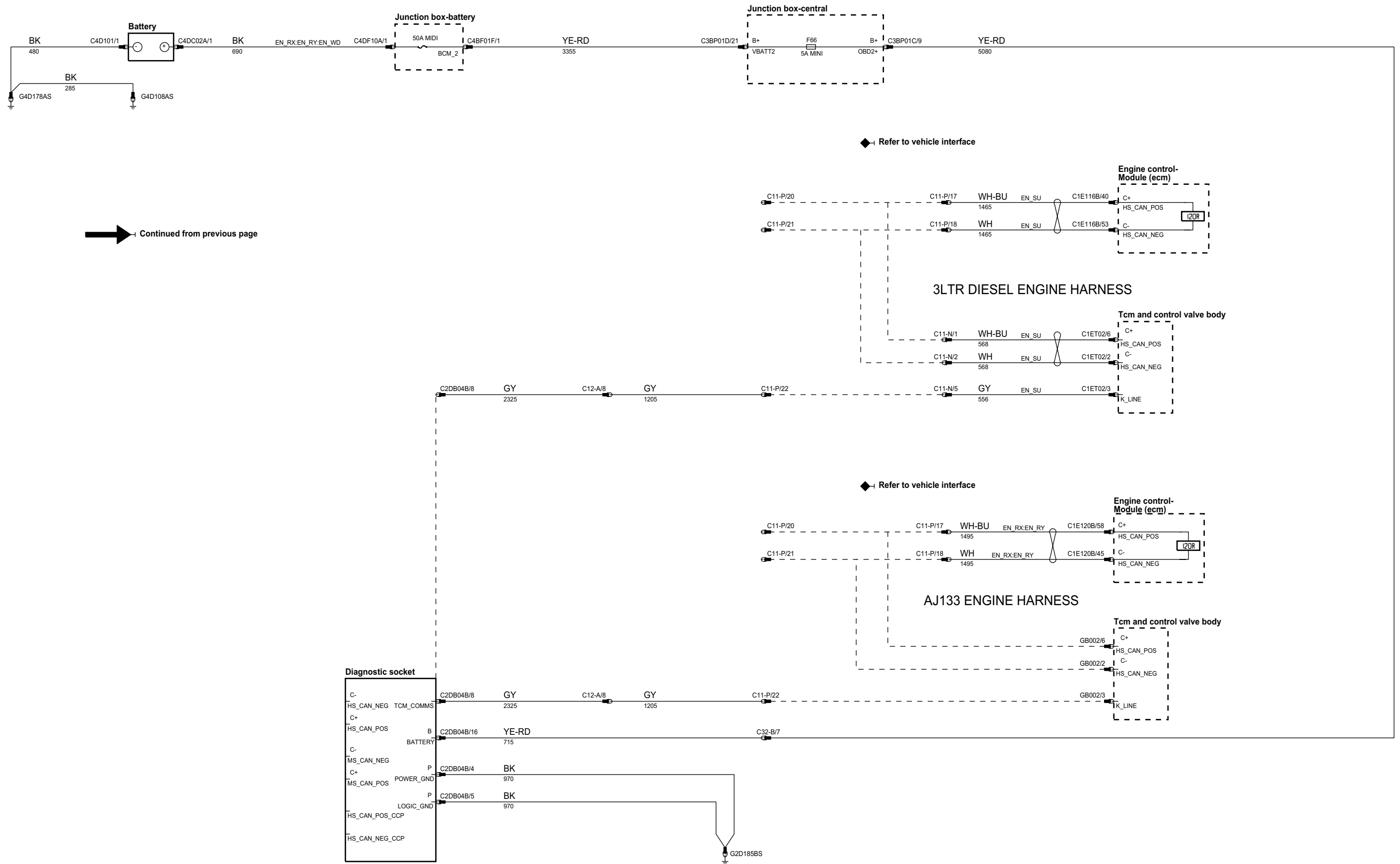

phcw93-70016-n-a3

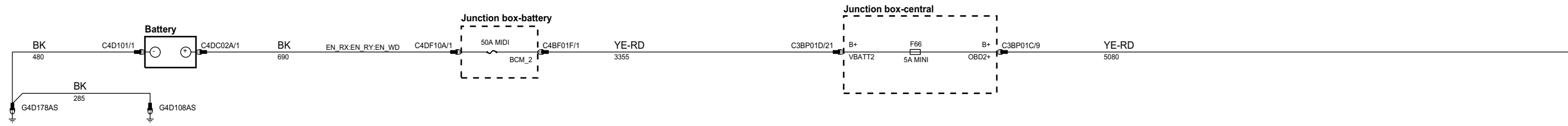

➔ Continued from previous page

◆ Refer to vehicle interface

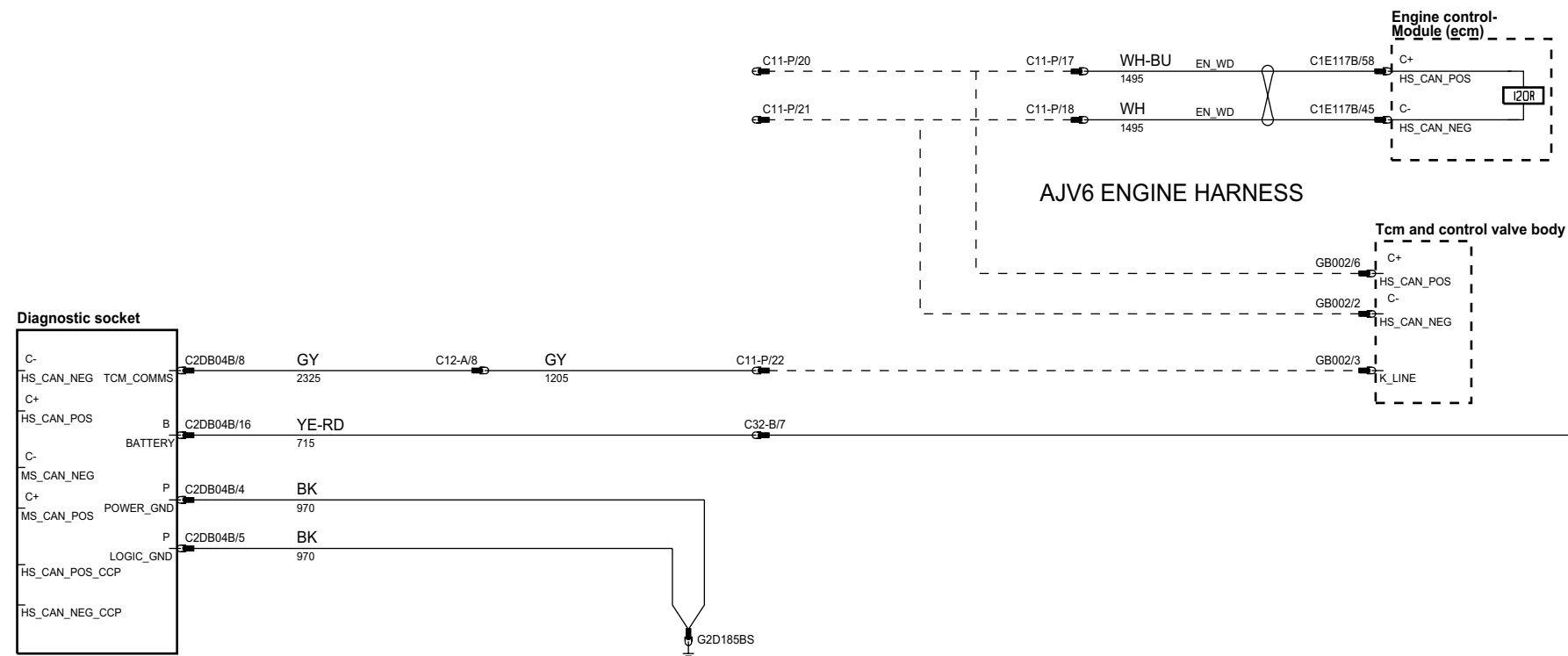

phcw93-70016-p-a3

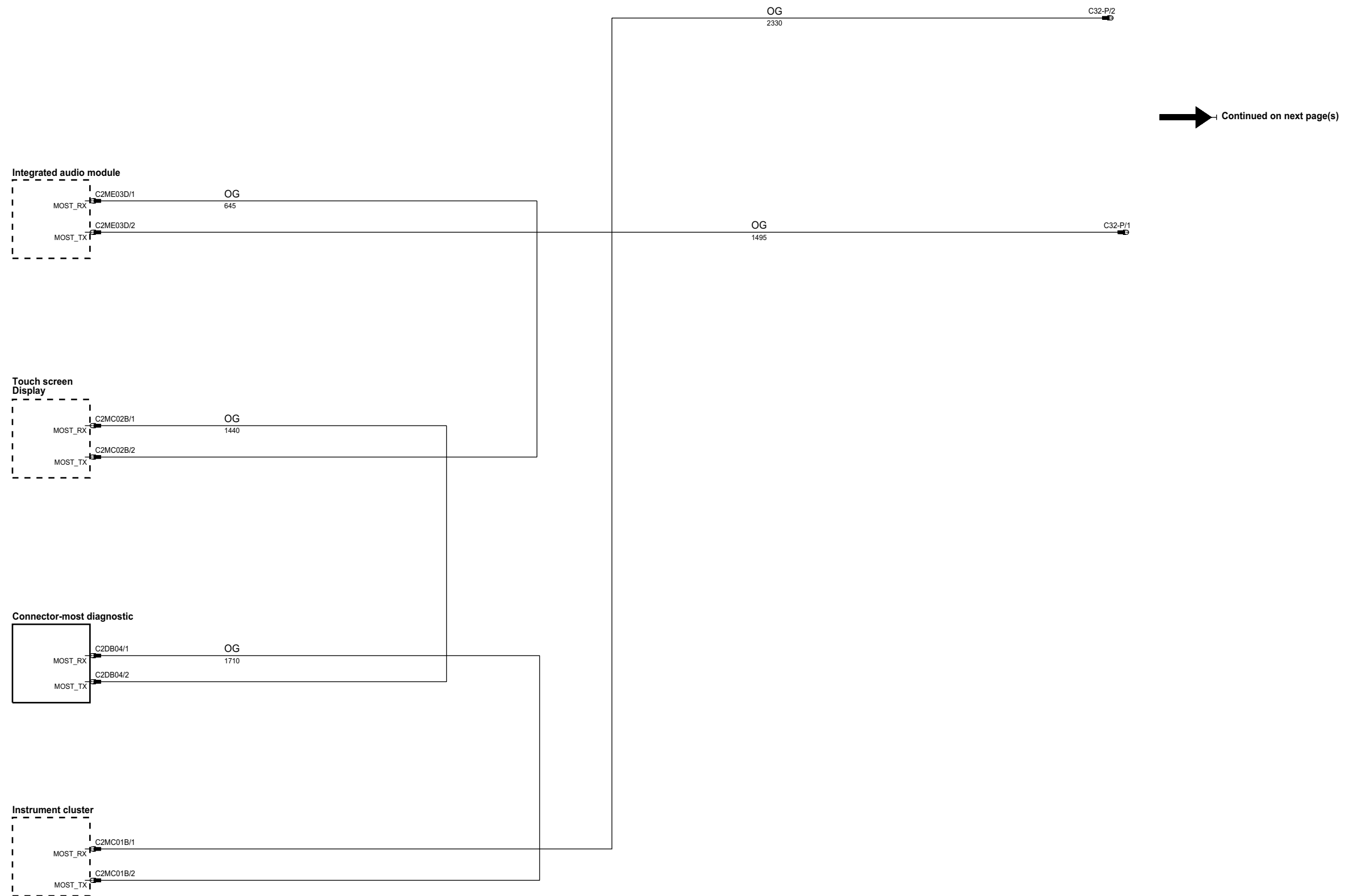

phcw93-70016-r-a3

Continued from part 1

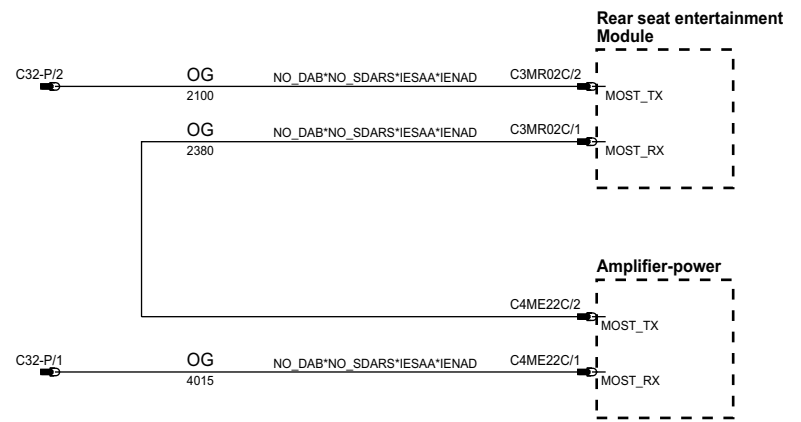
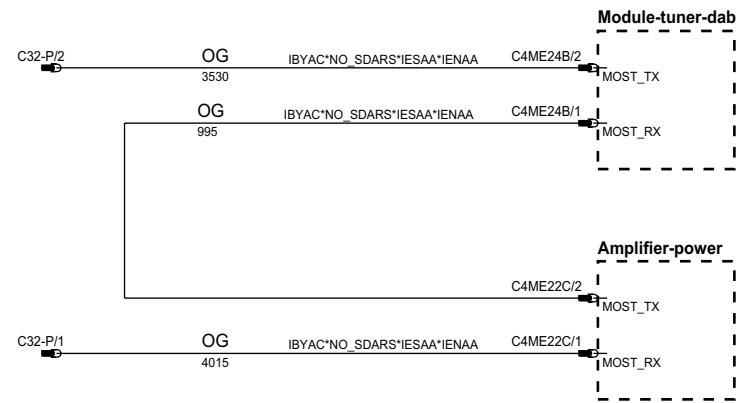
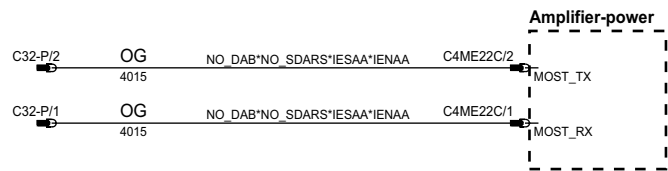
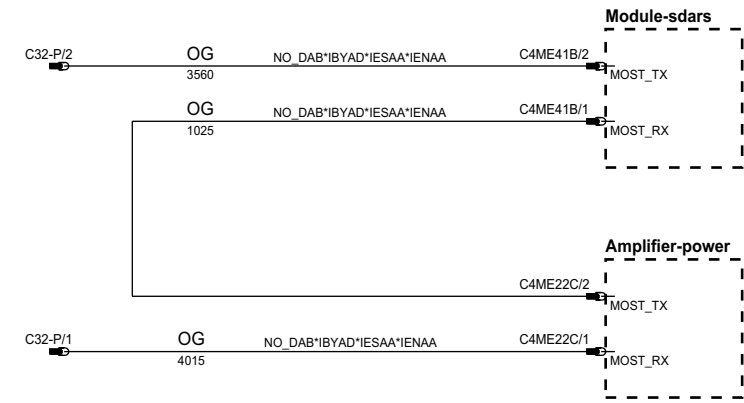
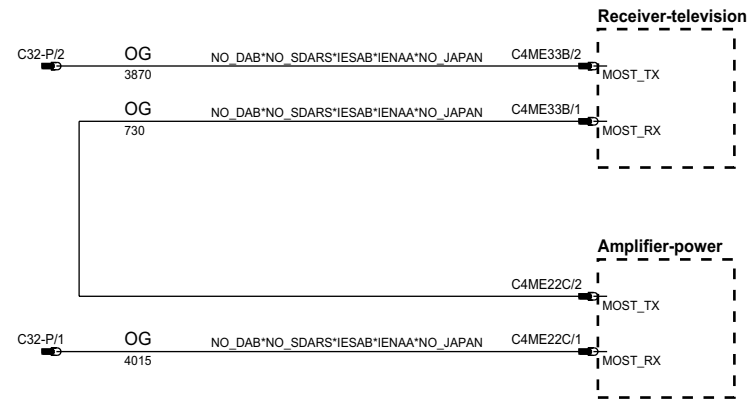

phcw93-70016-s-a3

Continued from part 1

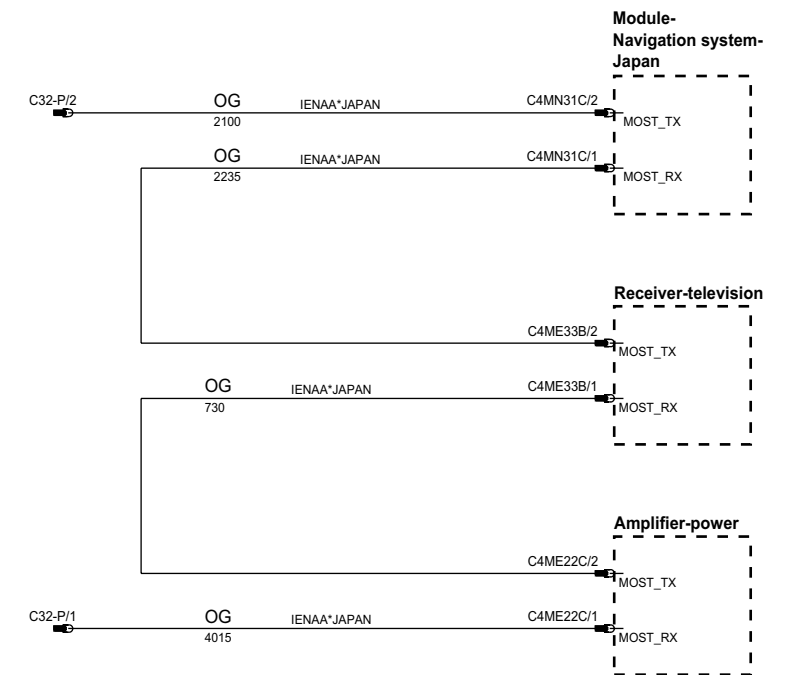
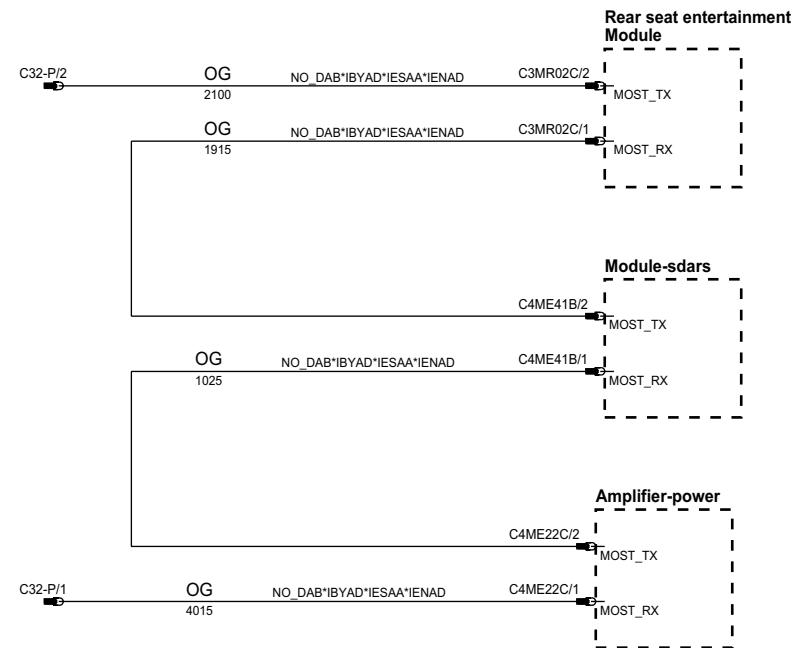
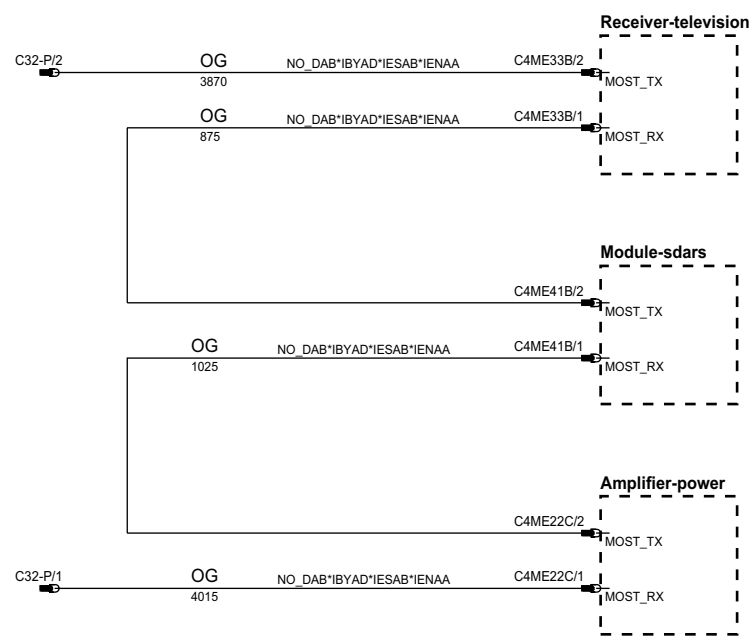
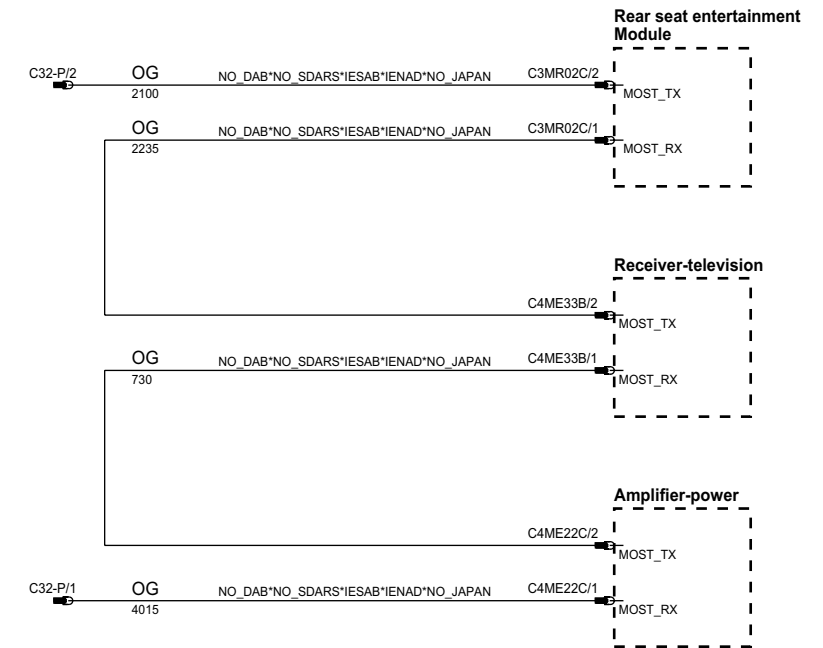
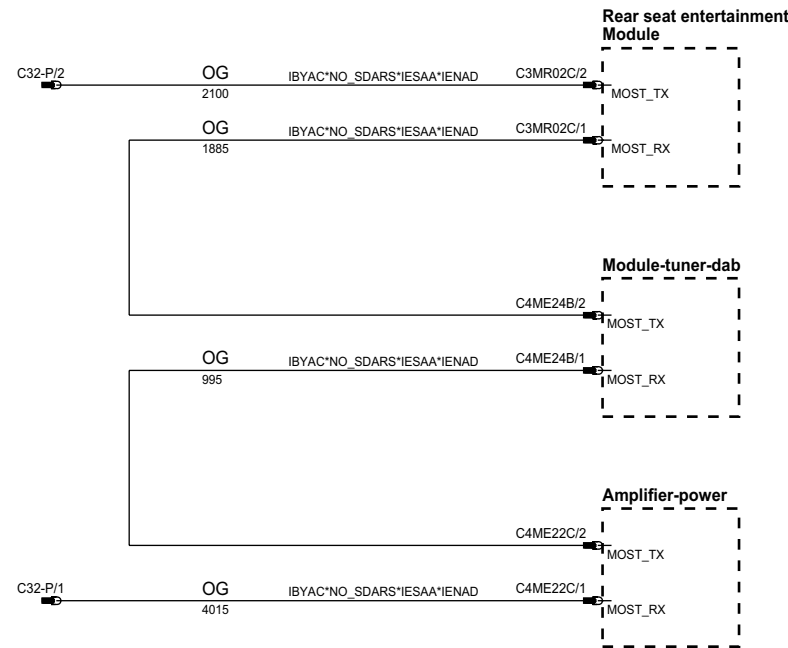
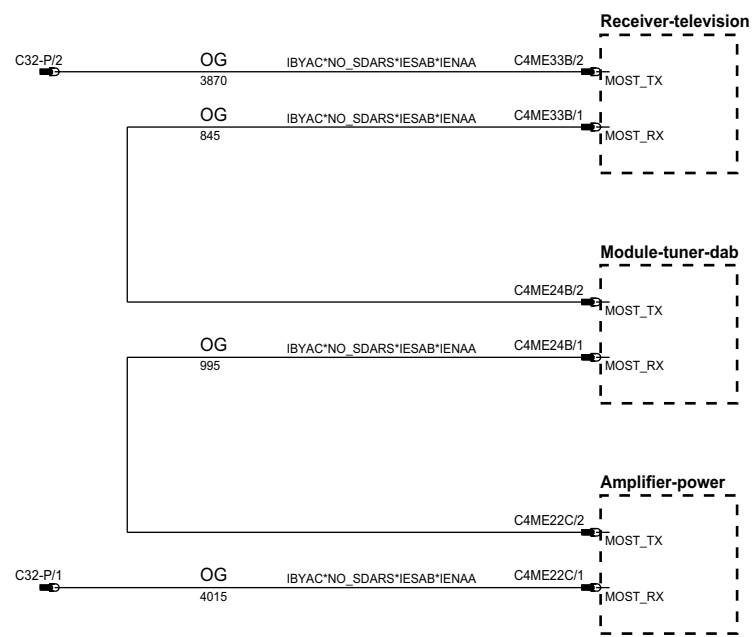

phcw93-70016-t-a3

Continued from part 1

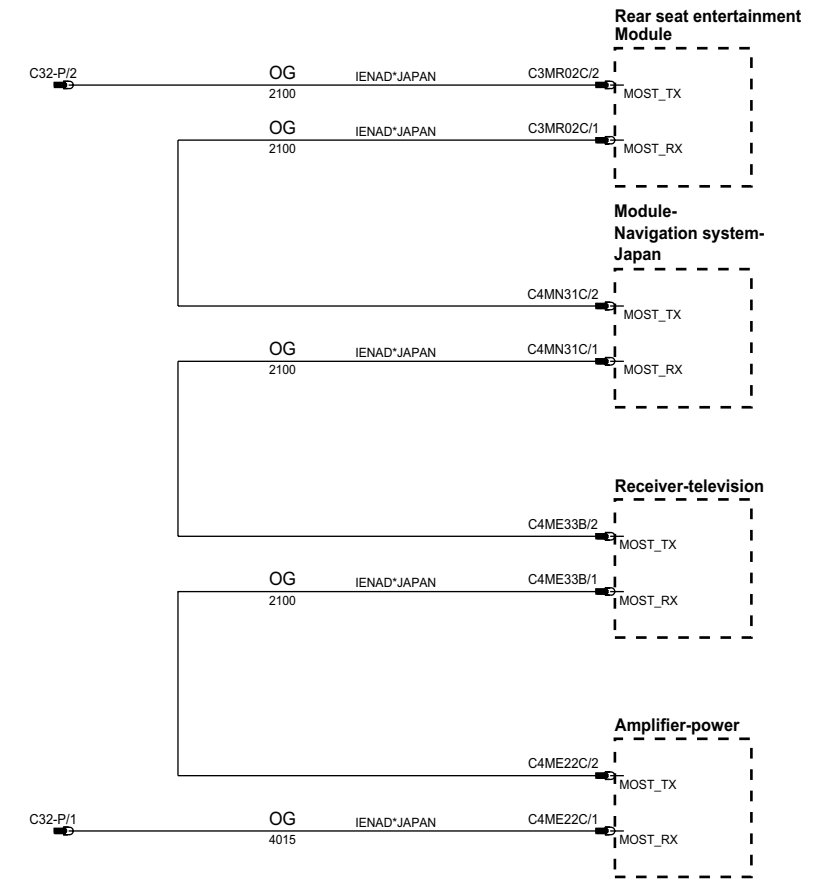
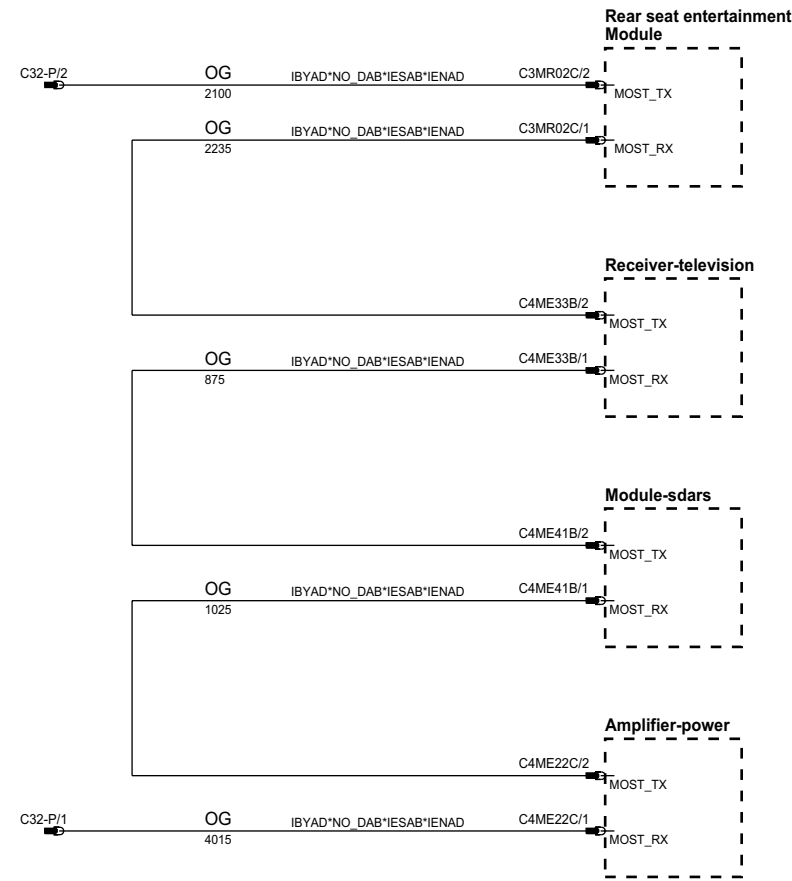
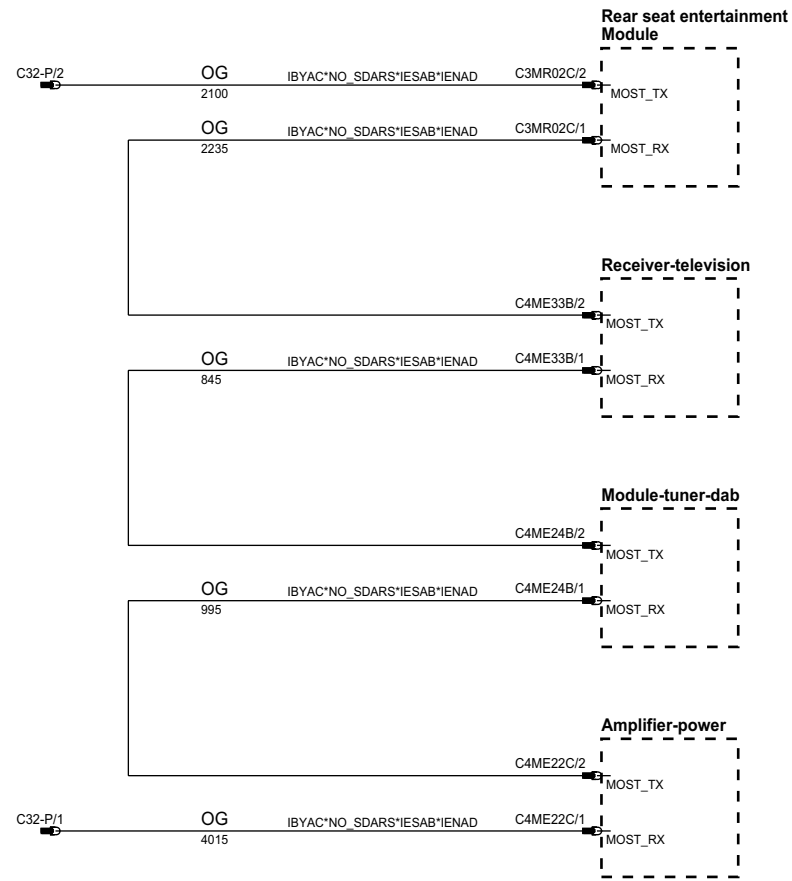

phcw93-70395-a-a3

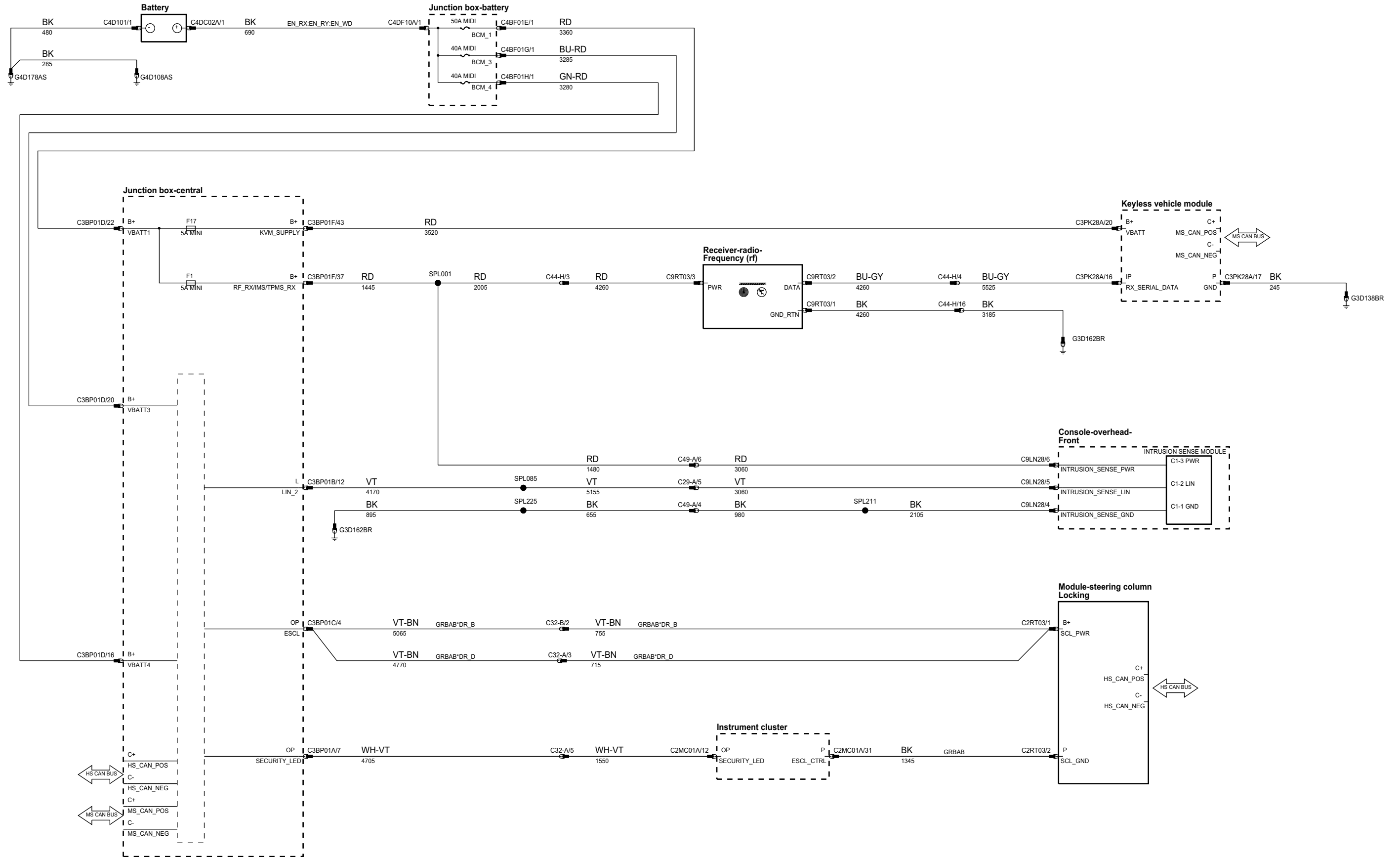

phcw93-70395-b-a3

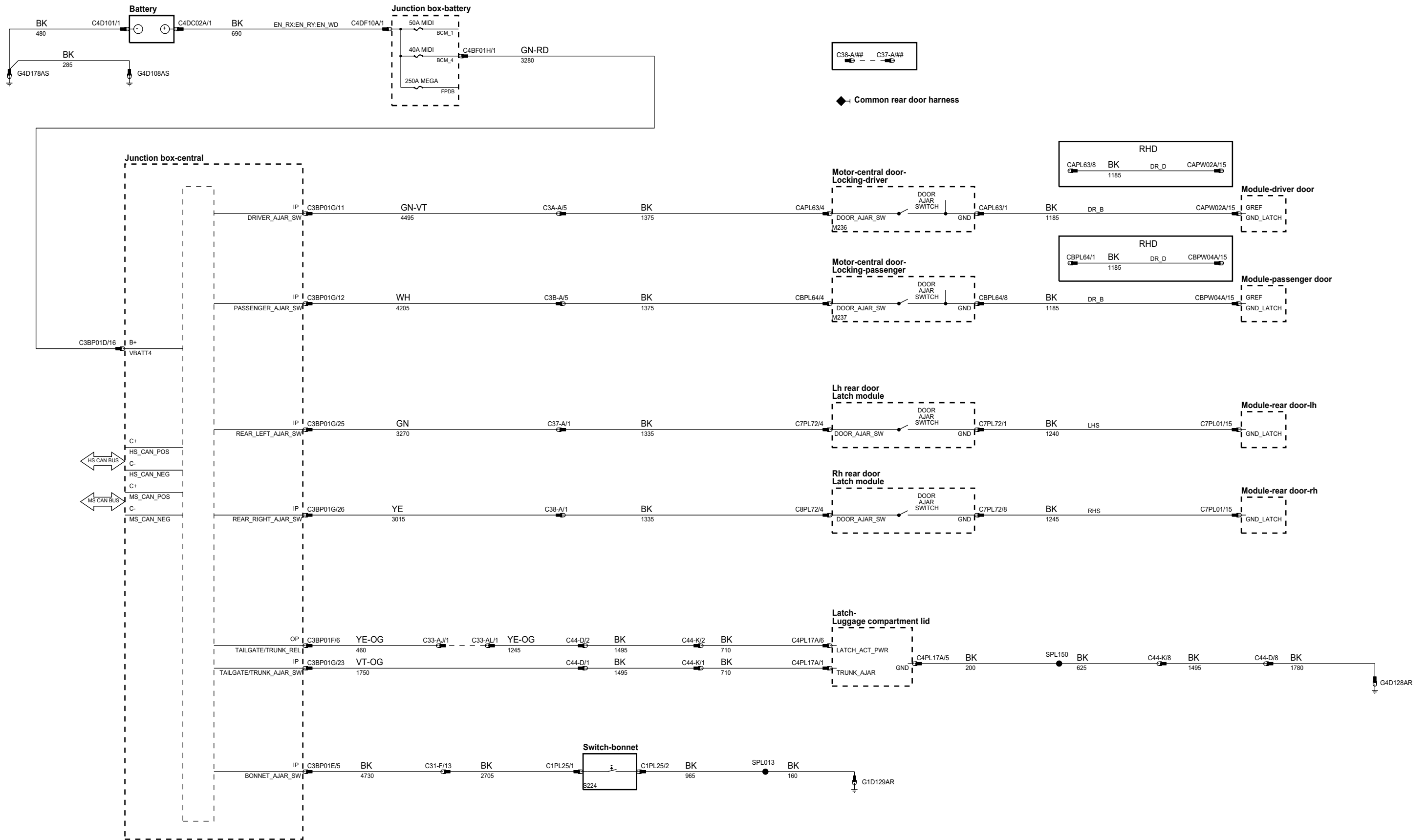

phcw93-70395-c-a3

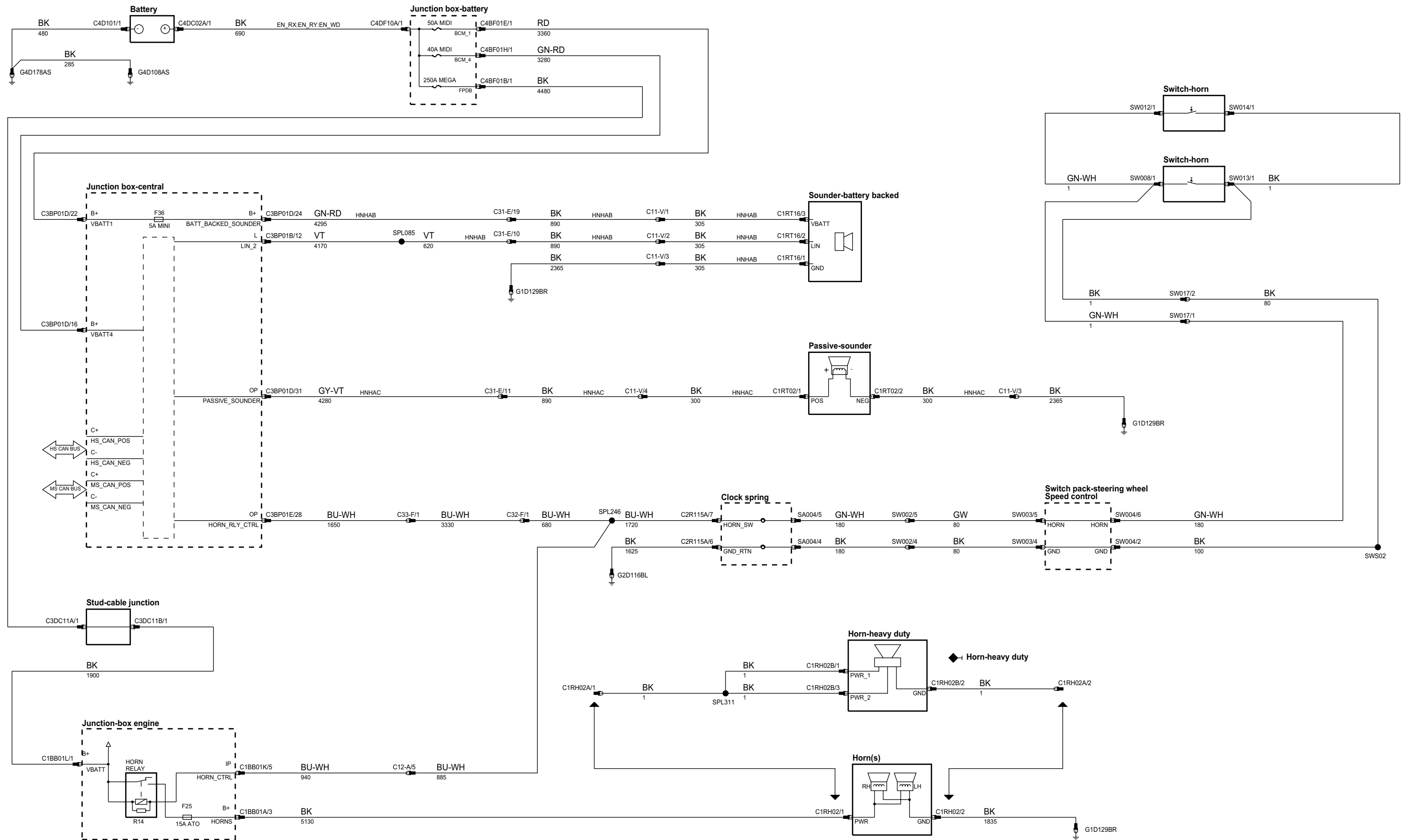

phcw93-70410-a-a3

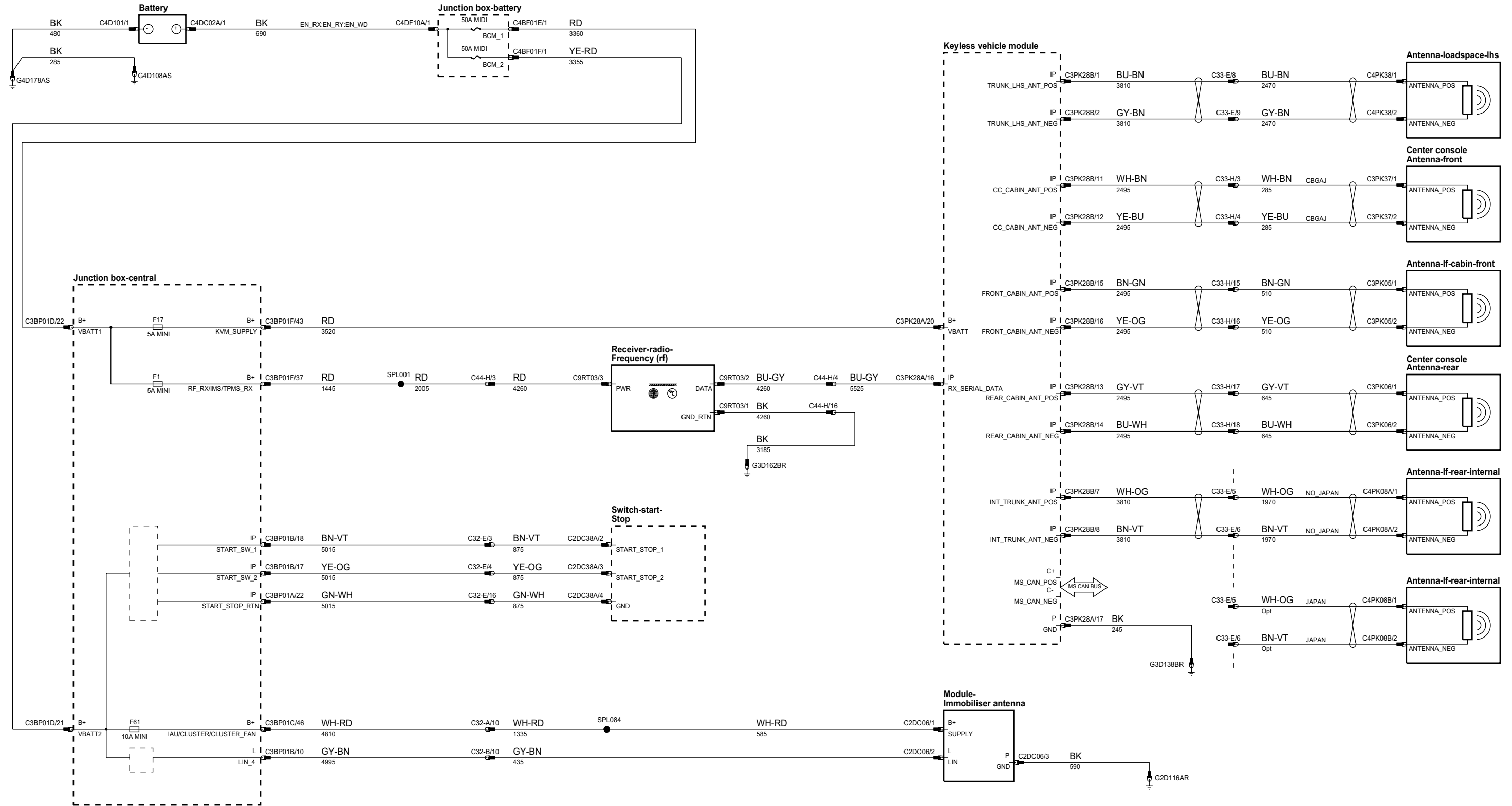

phcw93-70477-a-a3

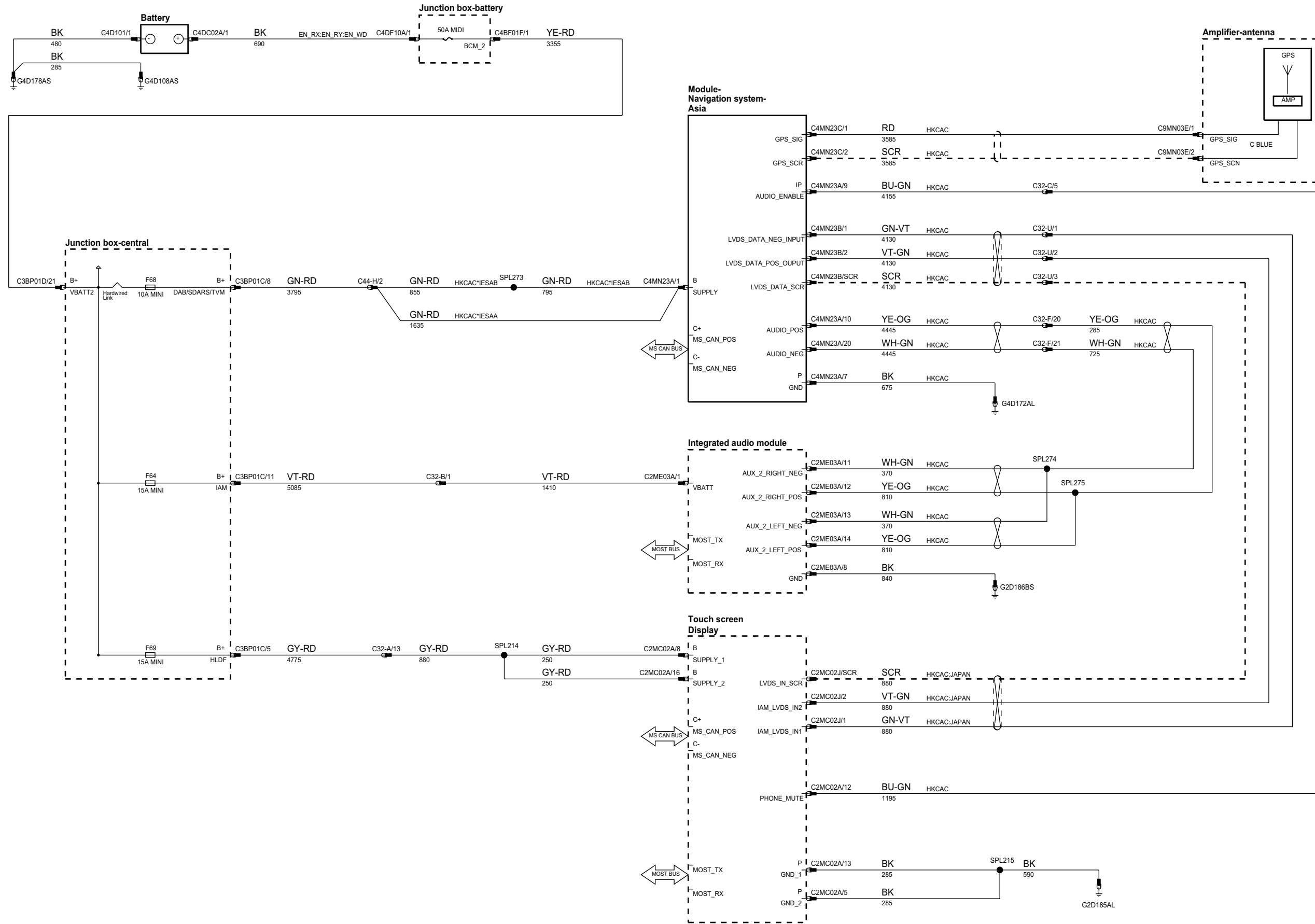

phcw93-70477-b-a3

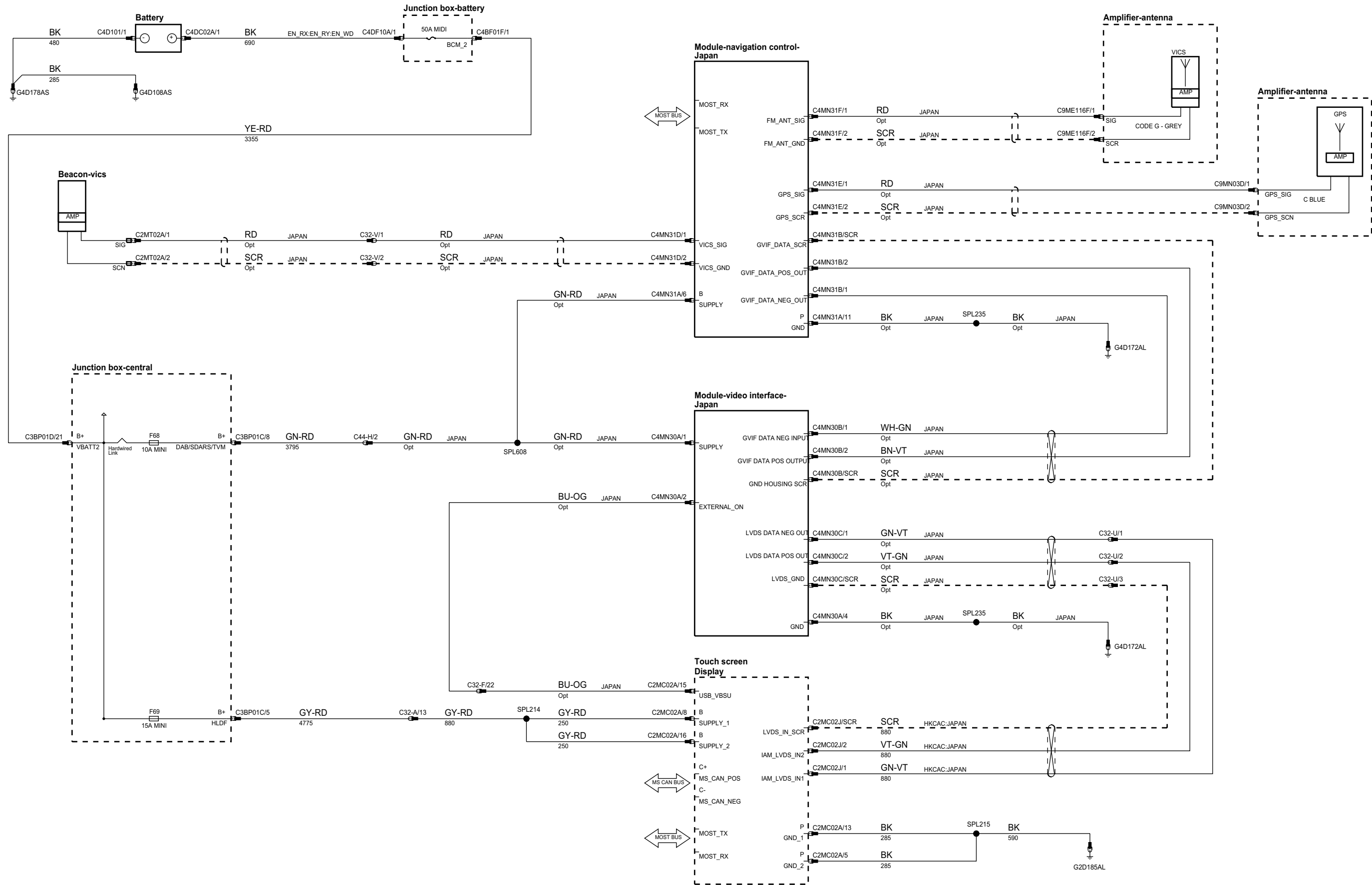

phcw93-70101-d-a3

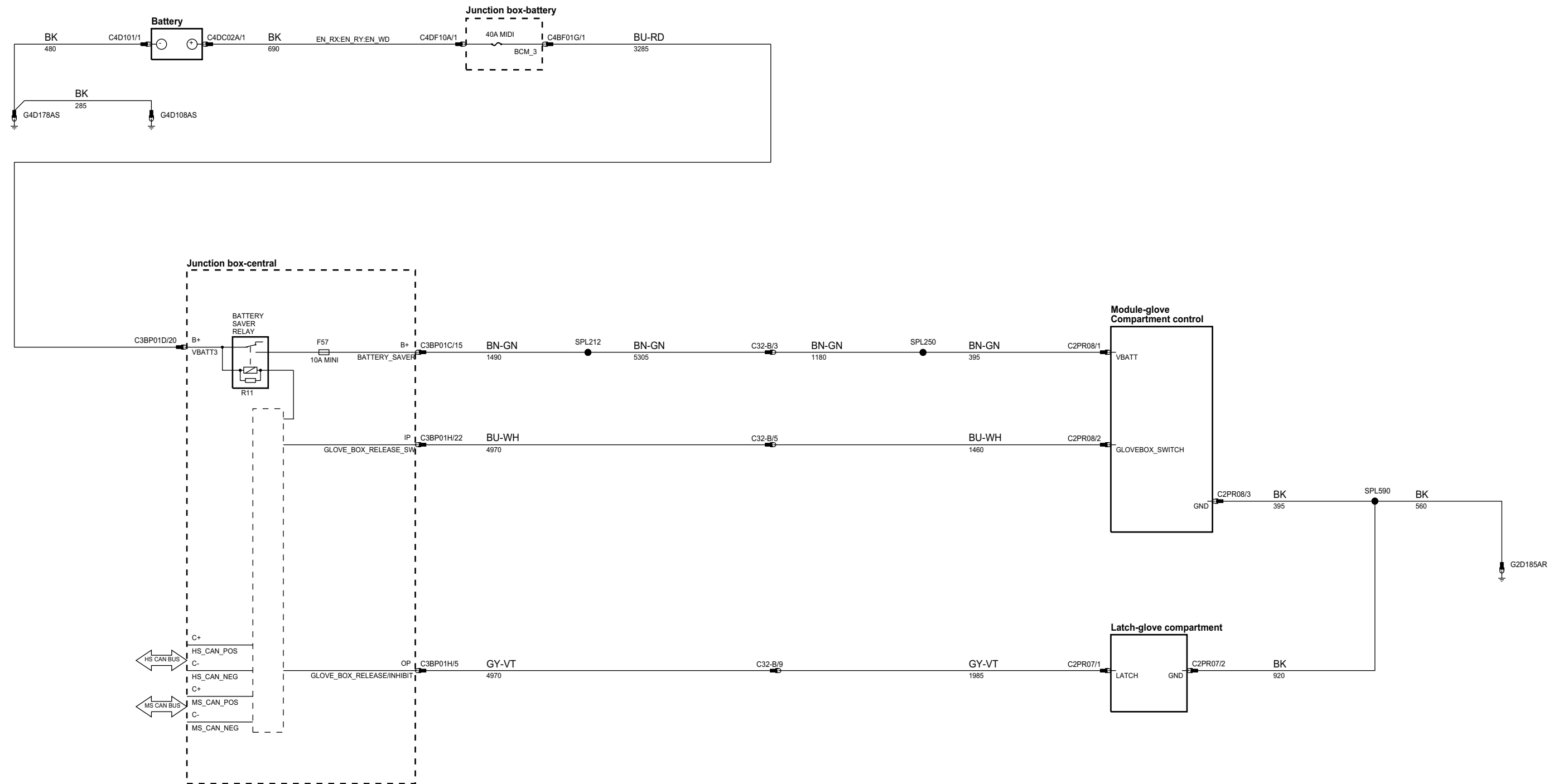

phcw93-70331-a-a3

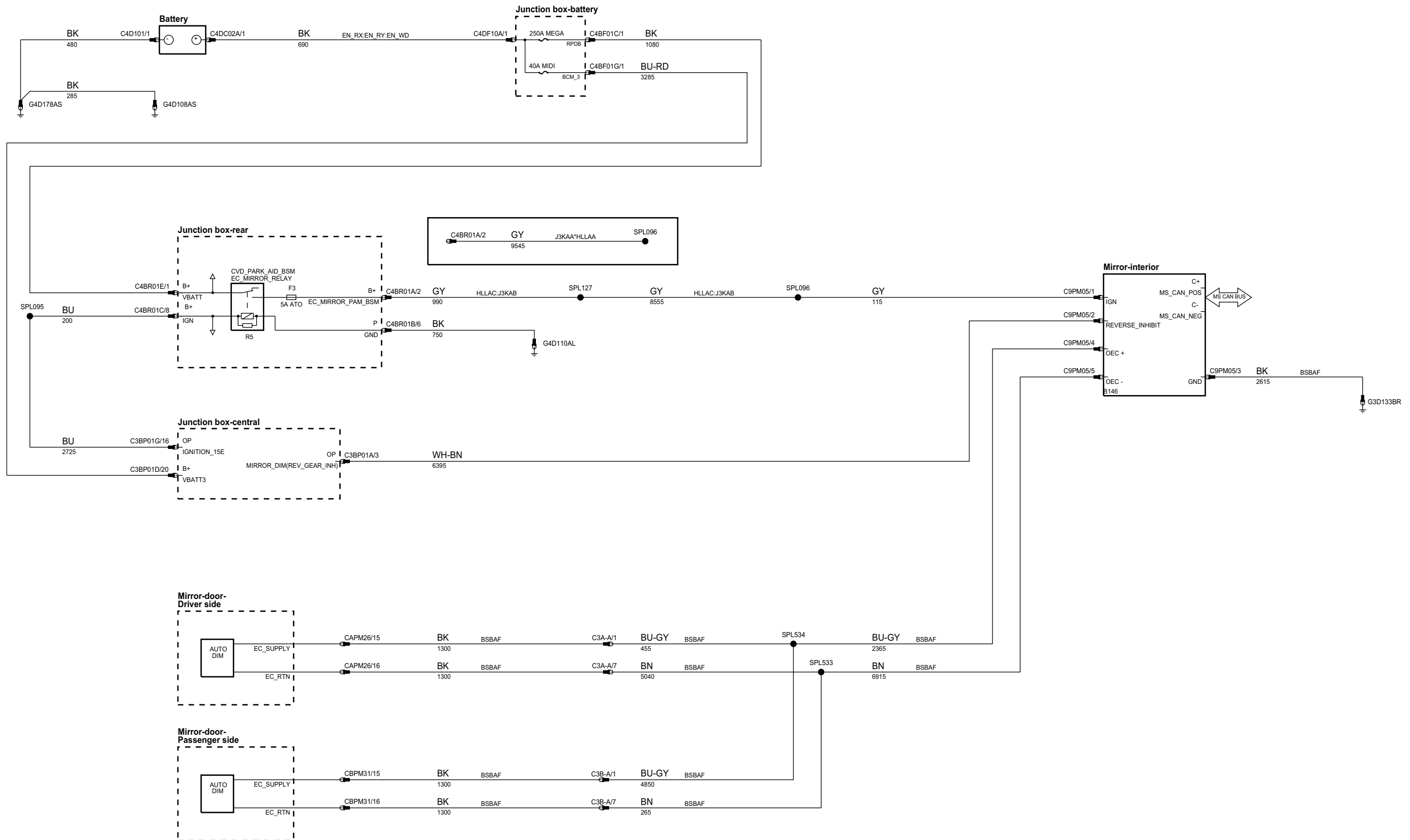

phcw93-70333-a-a3

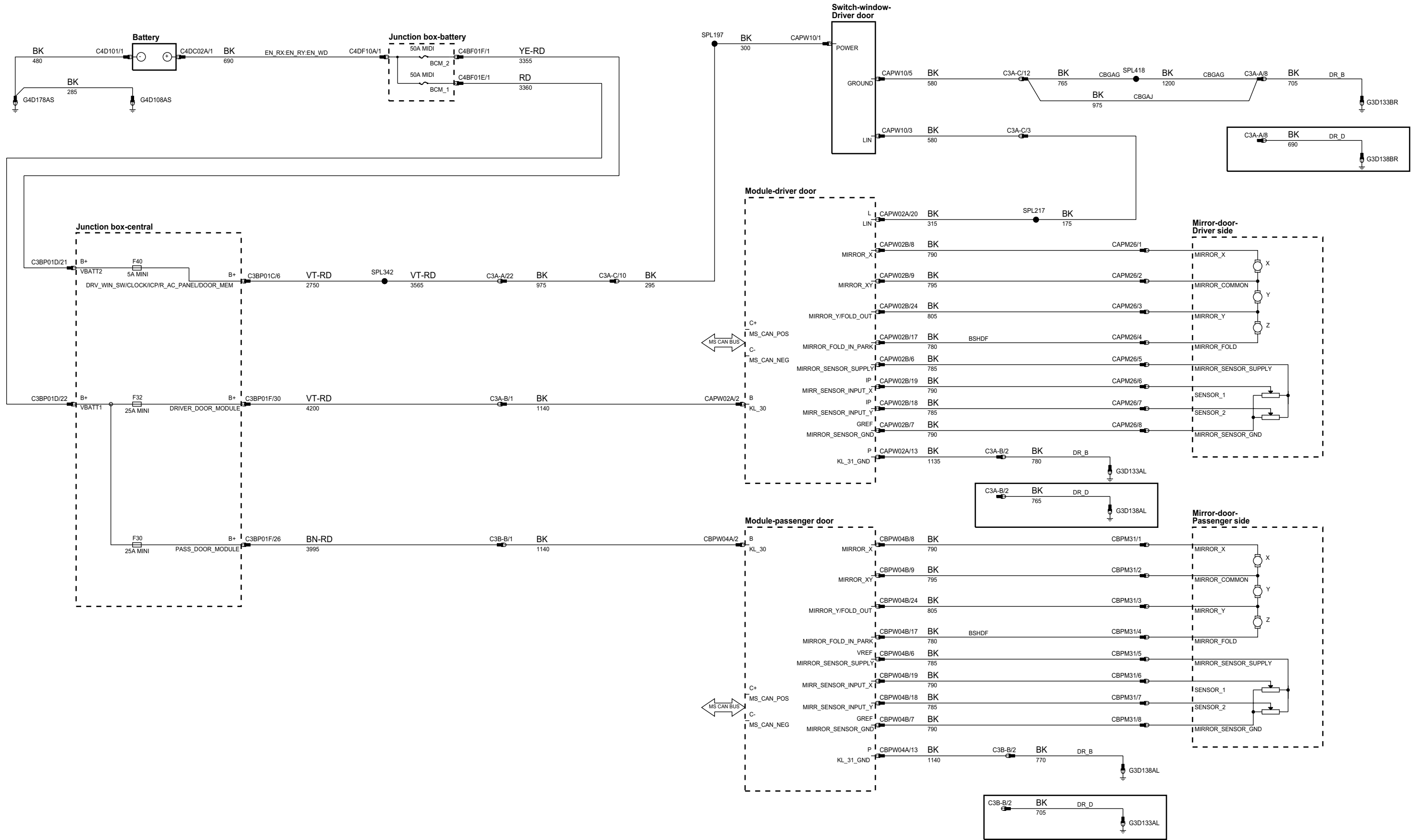

phcw93-70346-c-a3

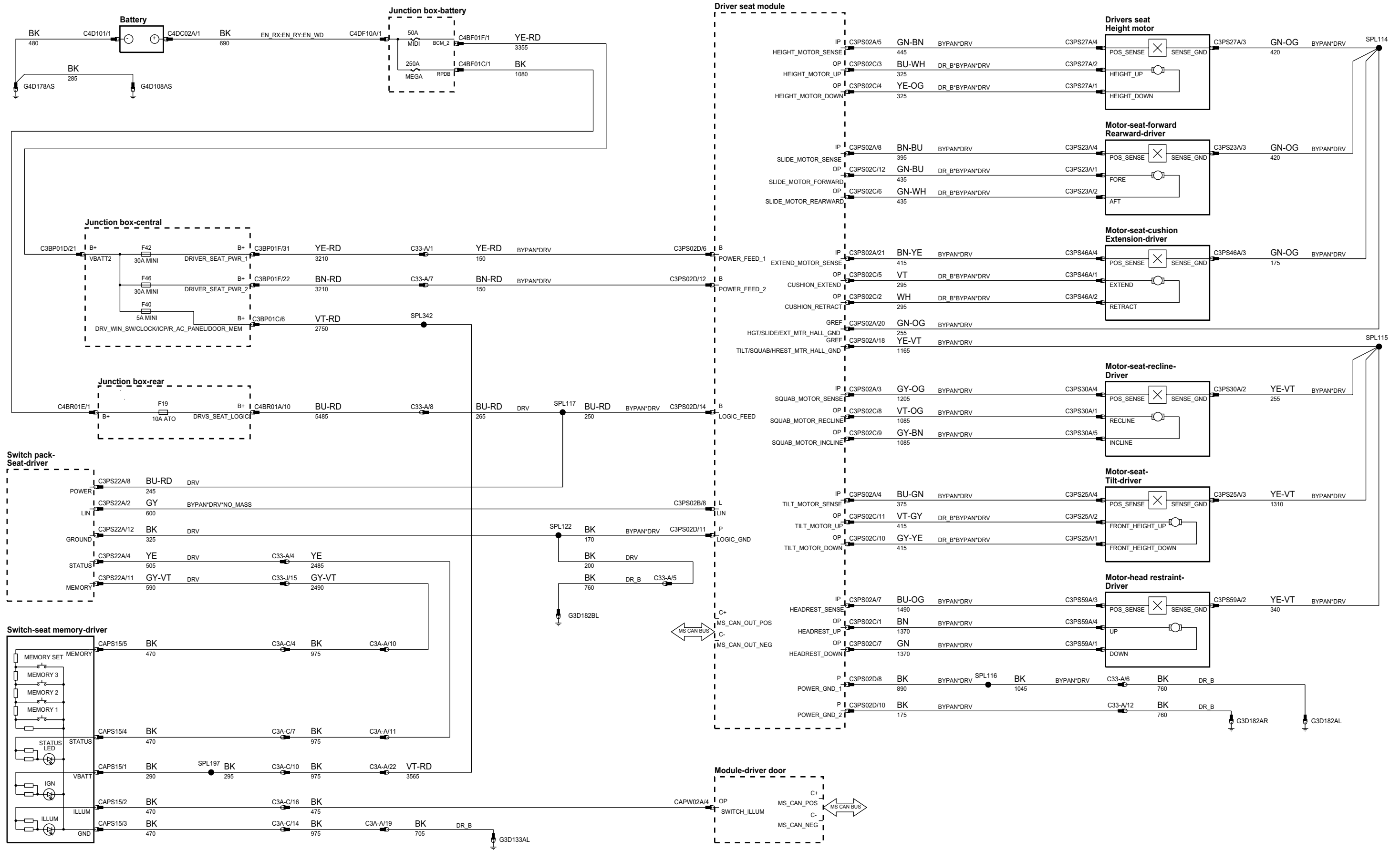

phcw93-70346-e-a3

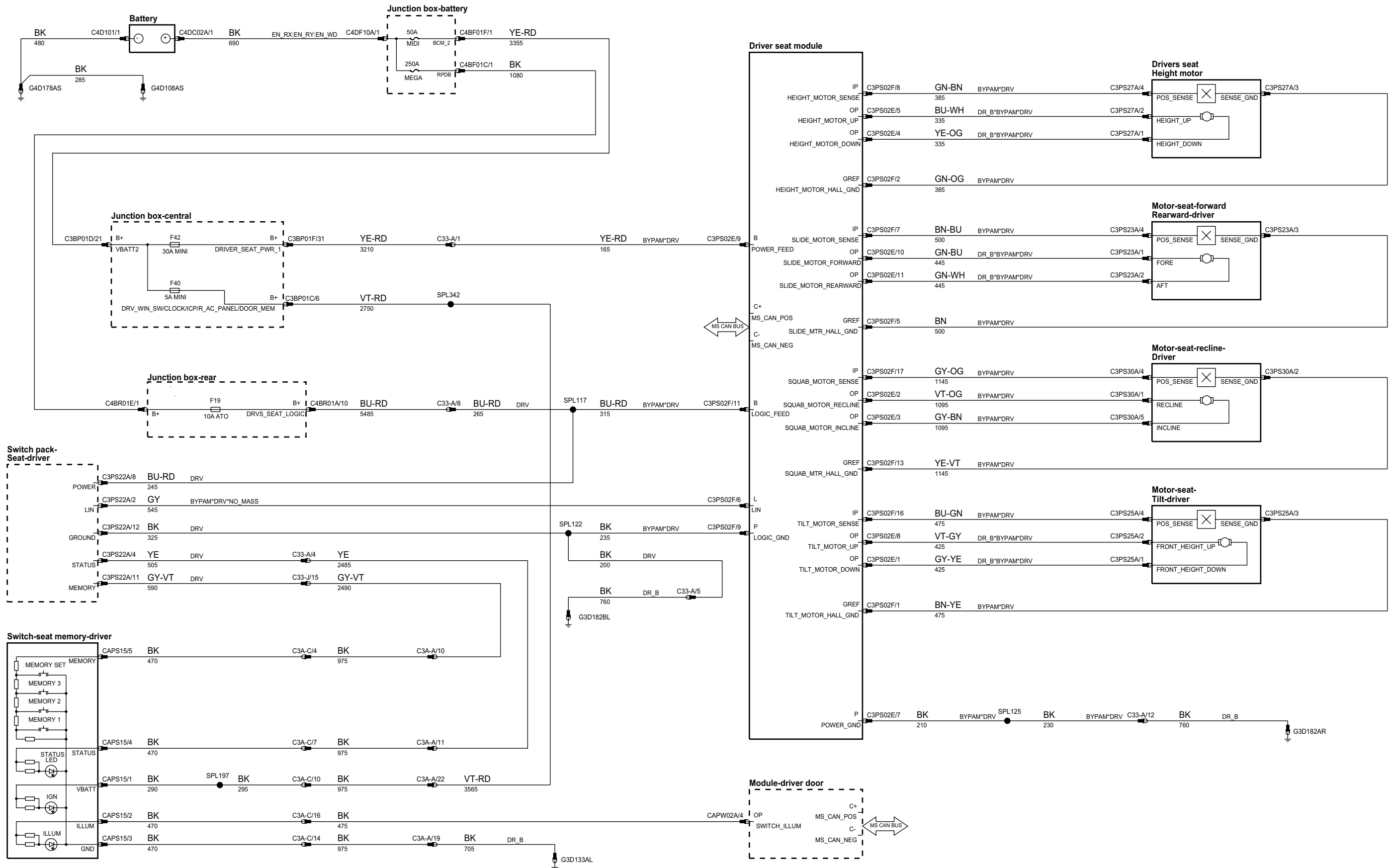

phcw93-70346-f-a3

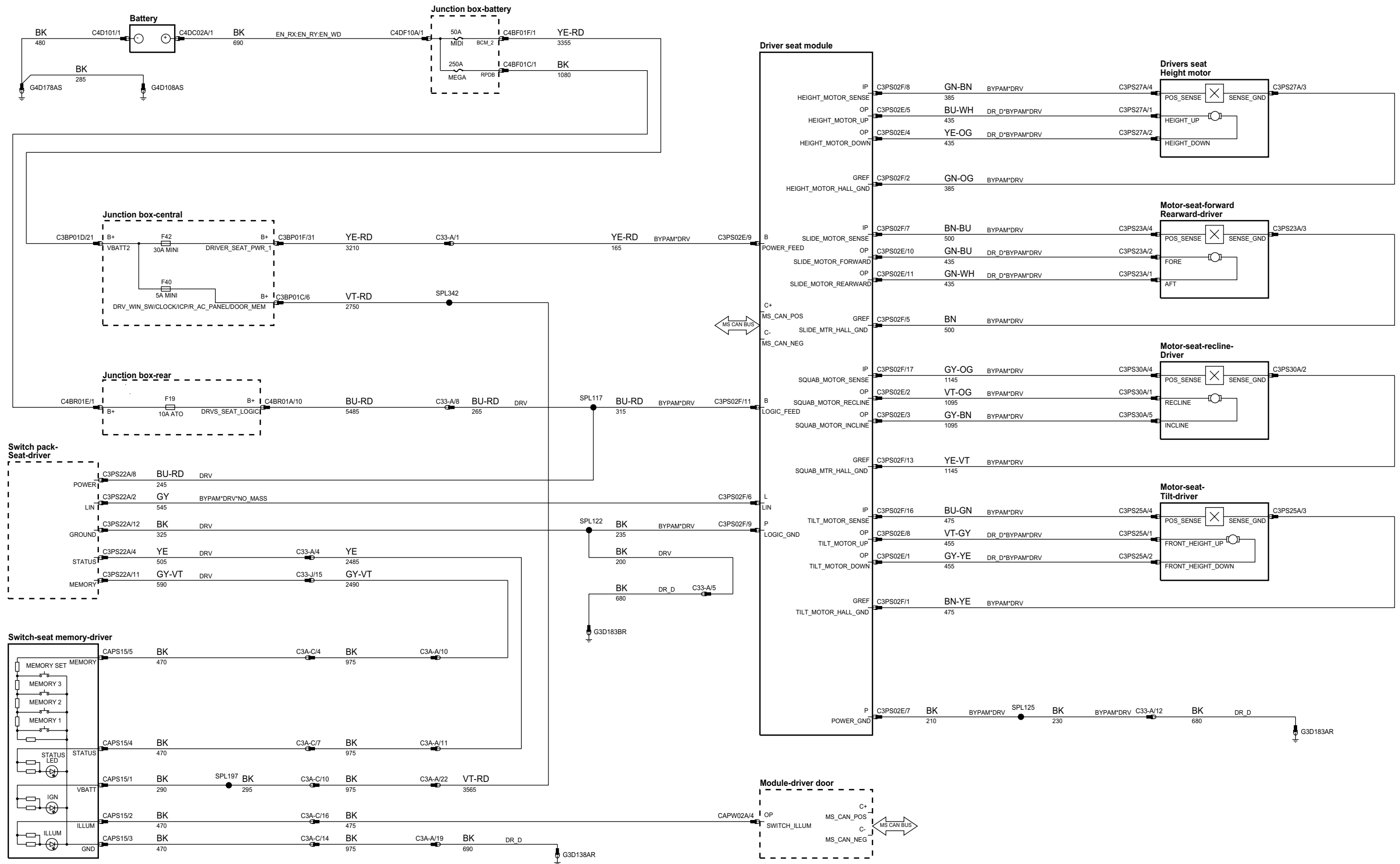

phcw93-70348-a-a3

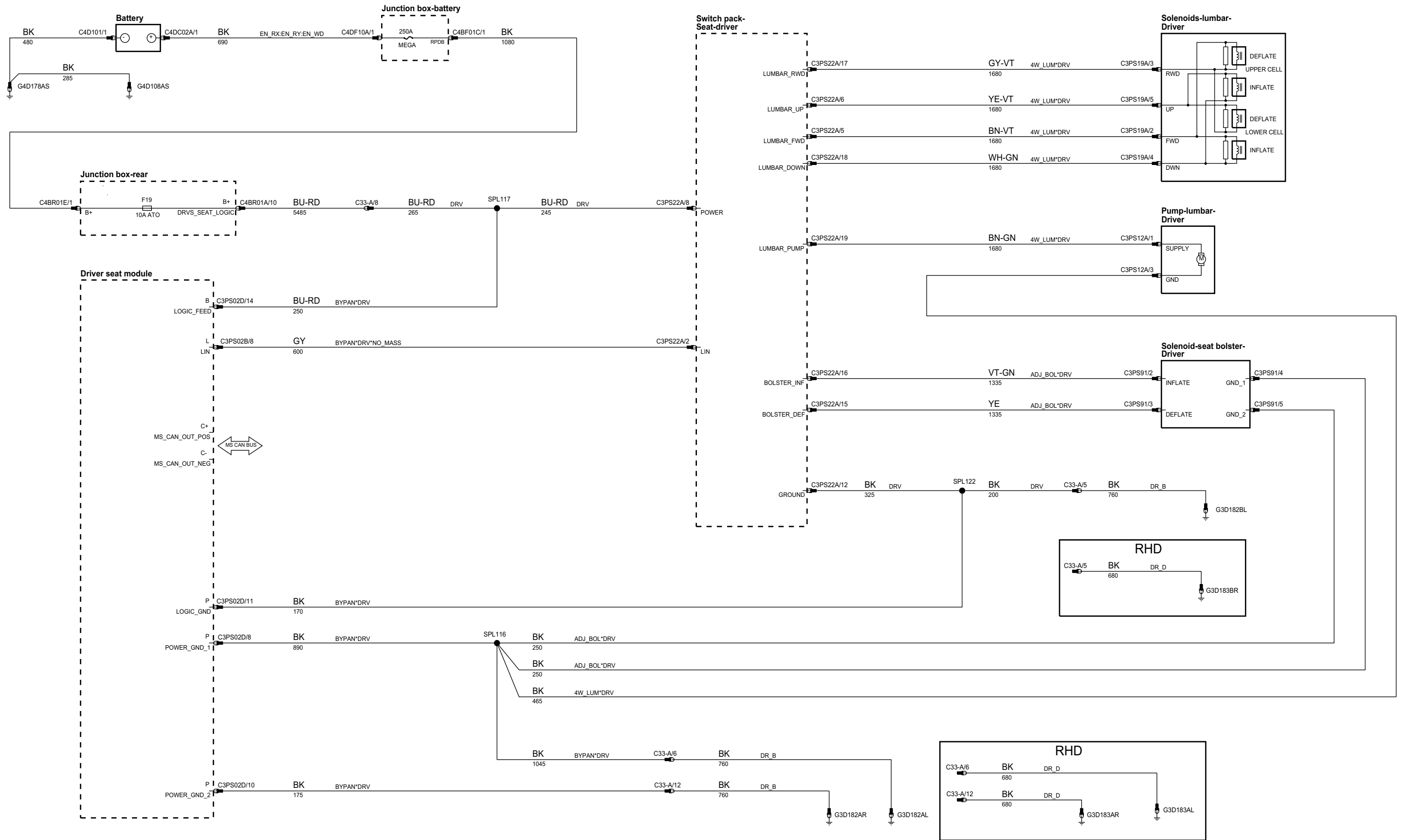

phcw93-70348-c-a3

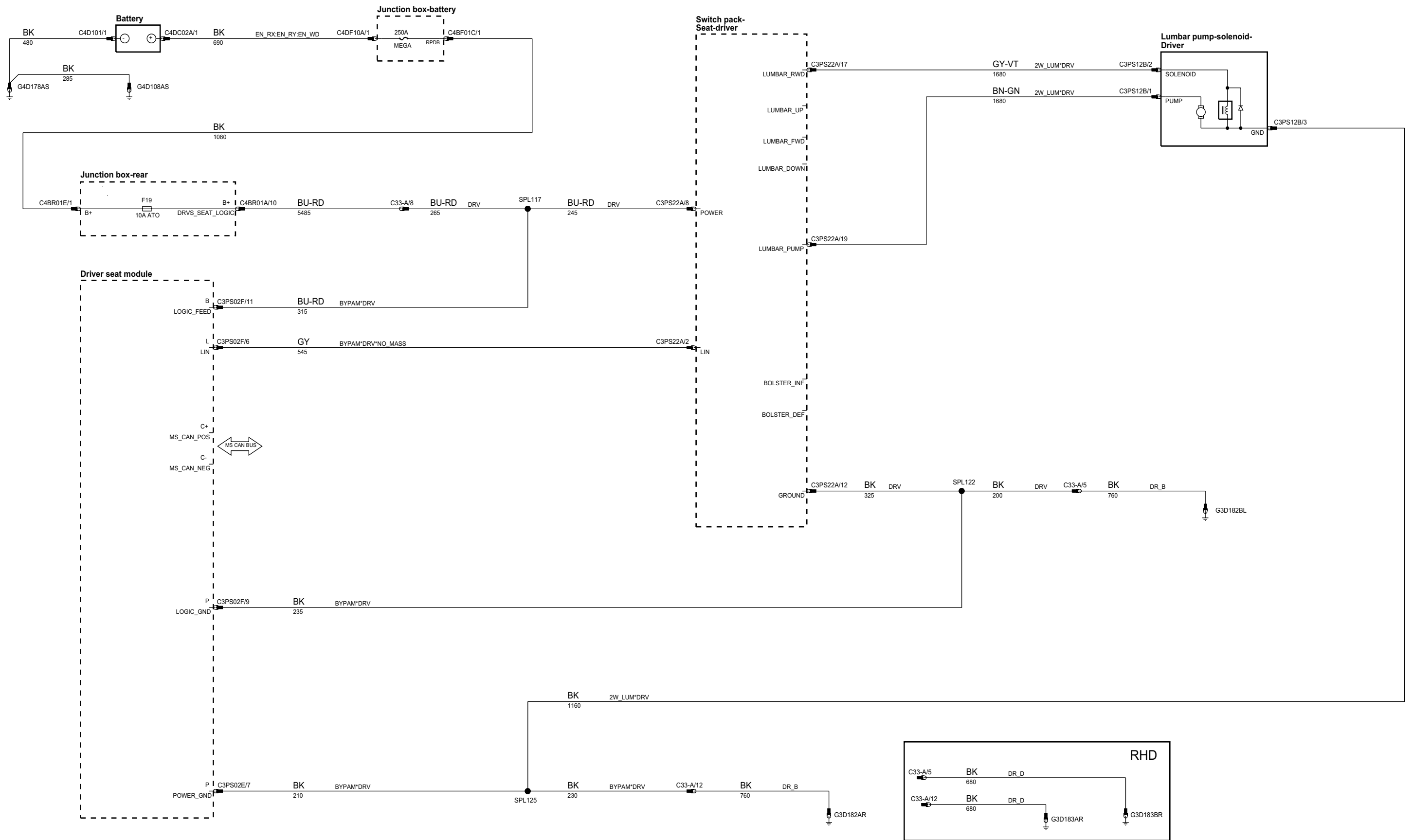

phcw93-70346-a-a3

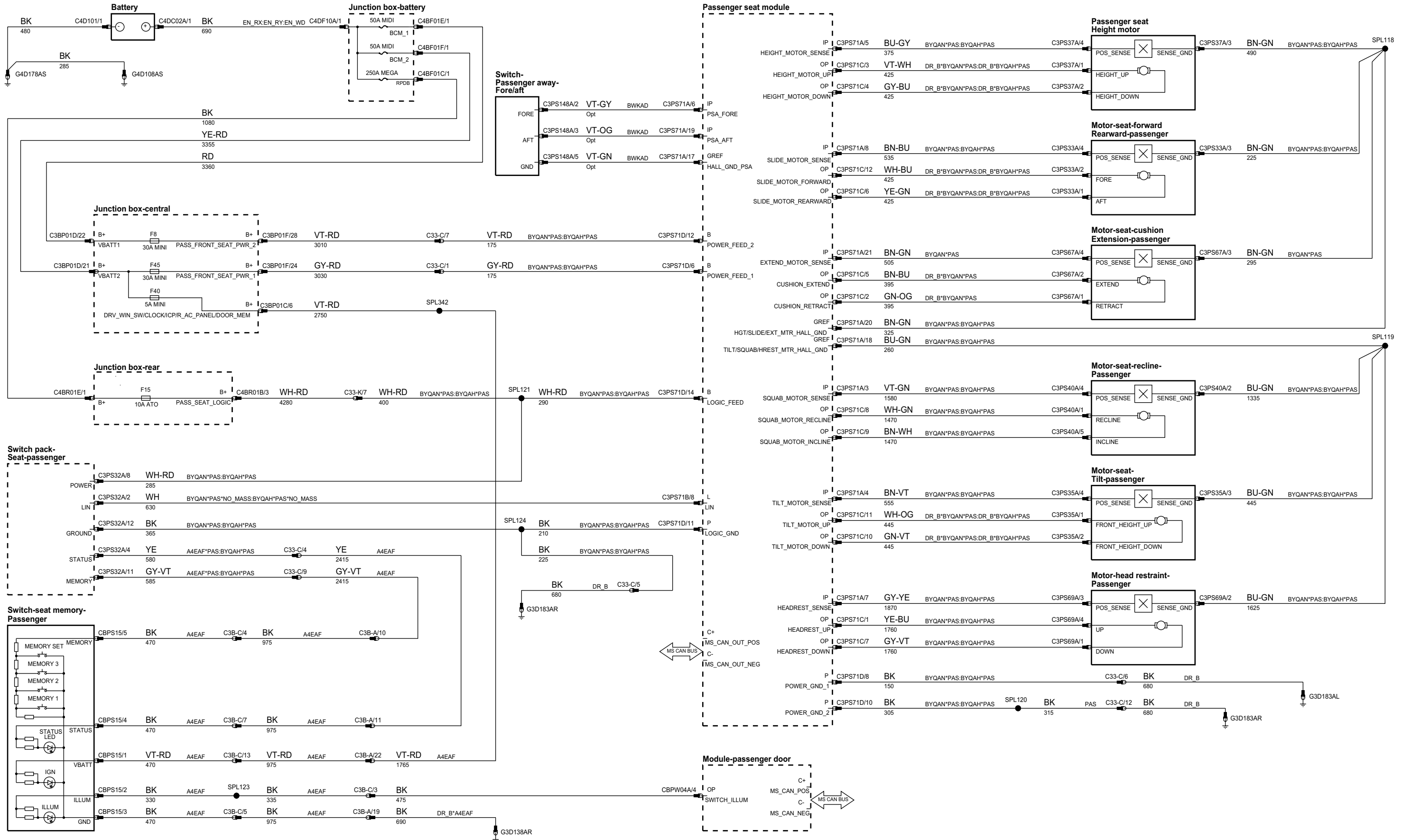

phcw93-70346-b-a3

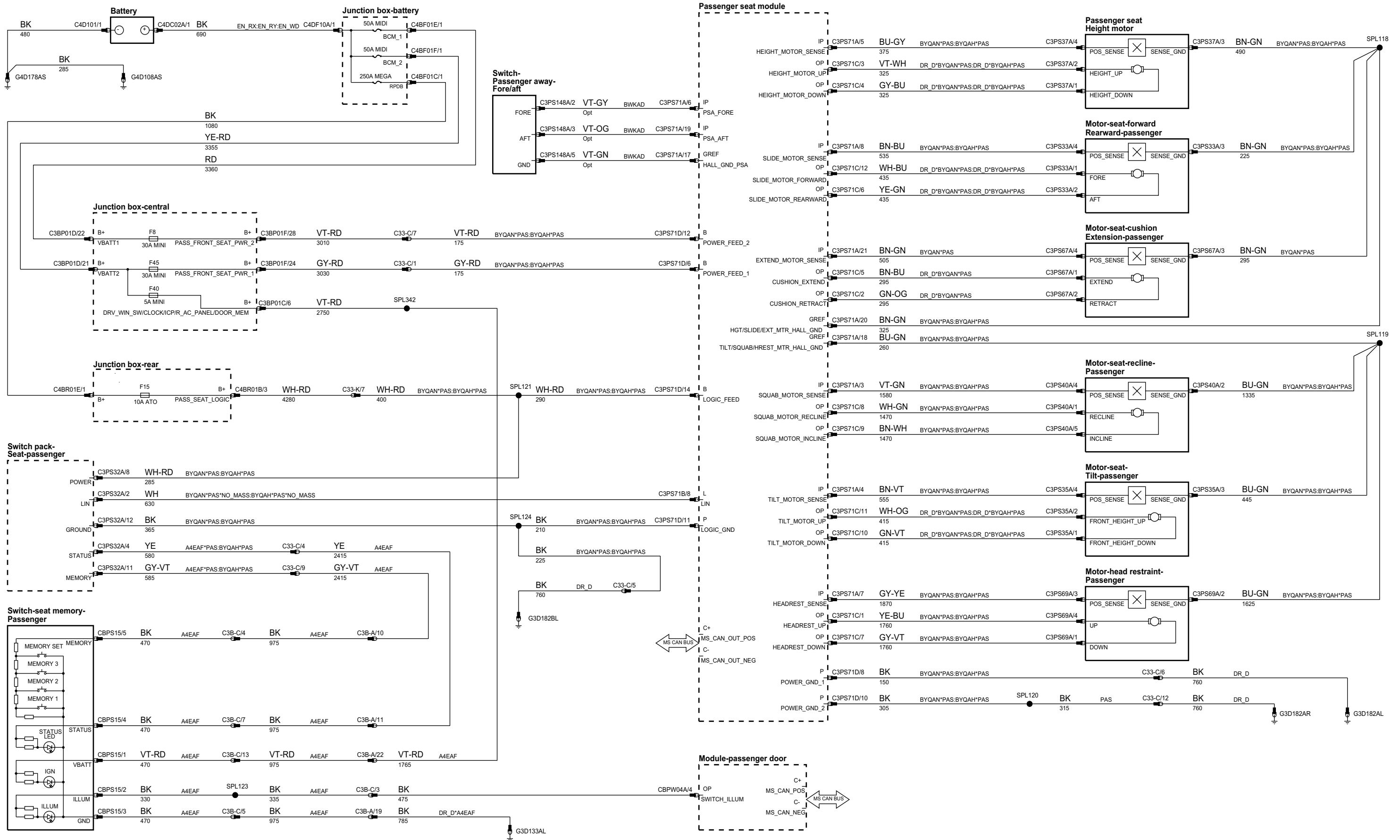

phcw93-70343-a-a3

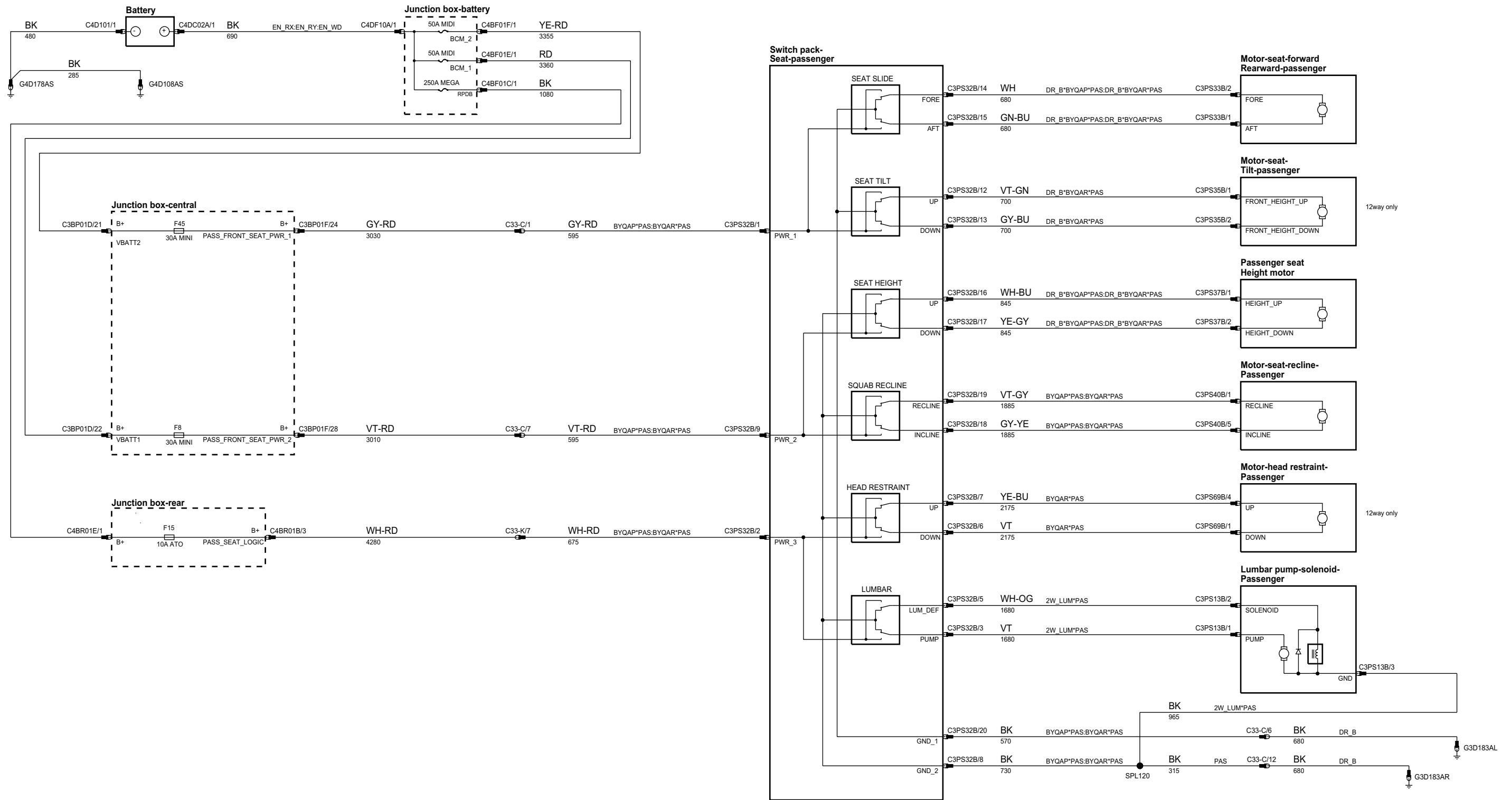

phcw93-70343-b-a3

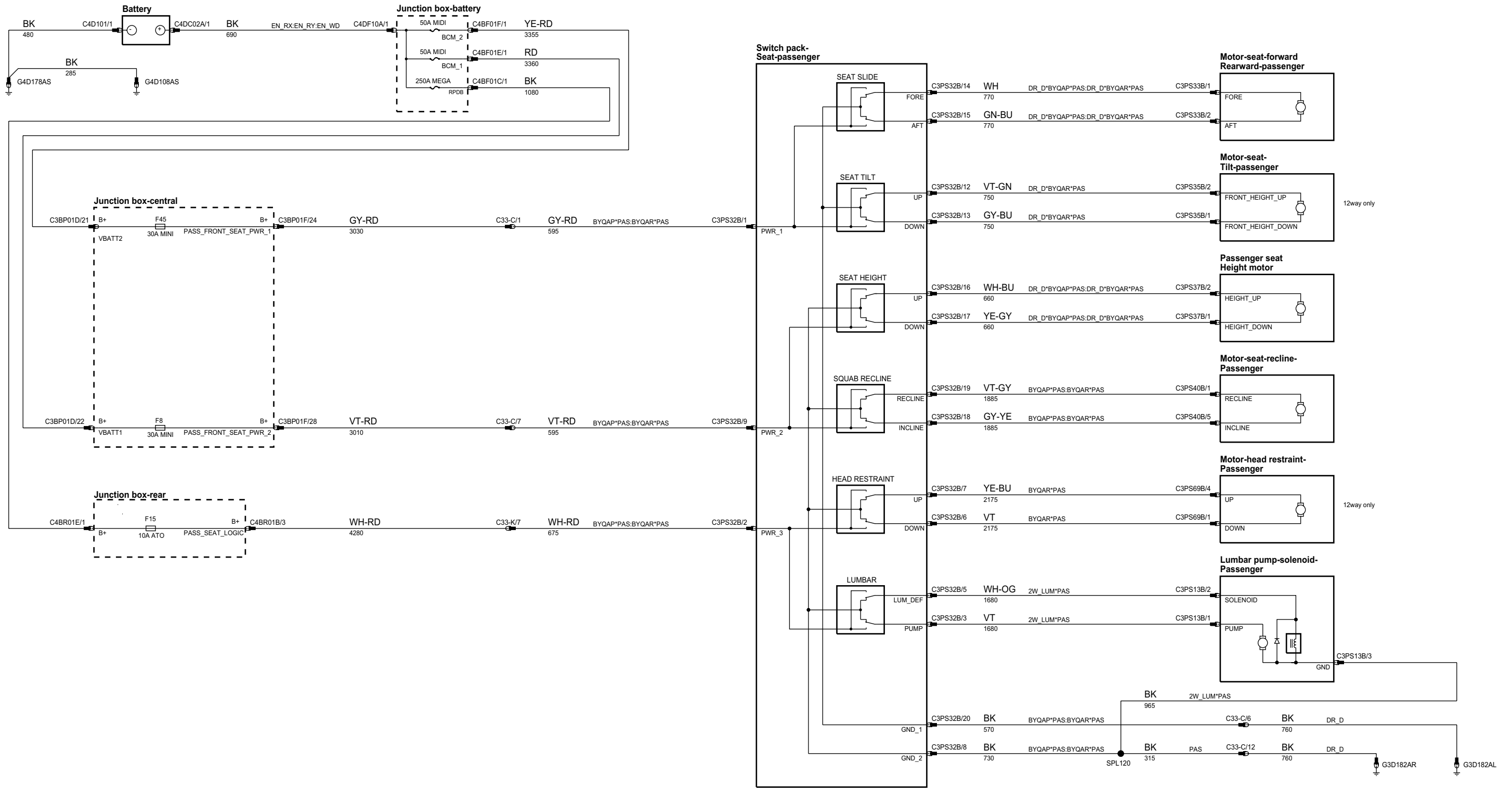

phcw93-70348-b-a3

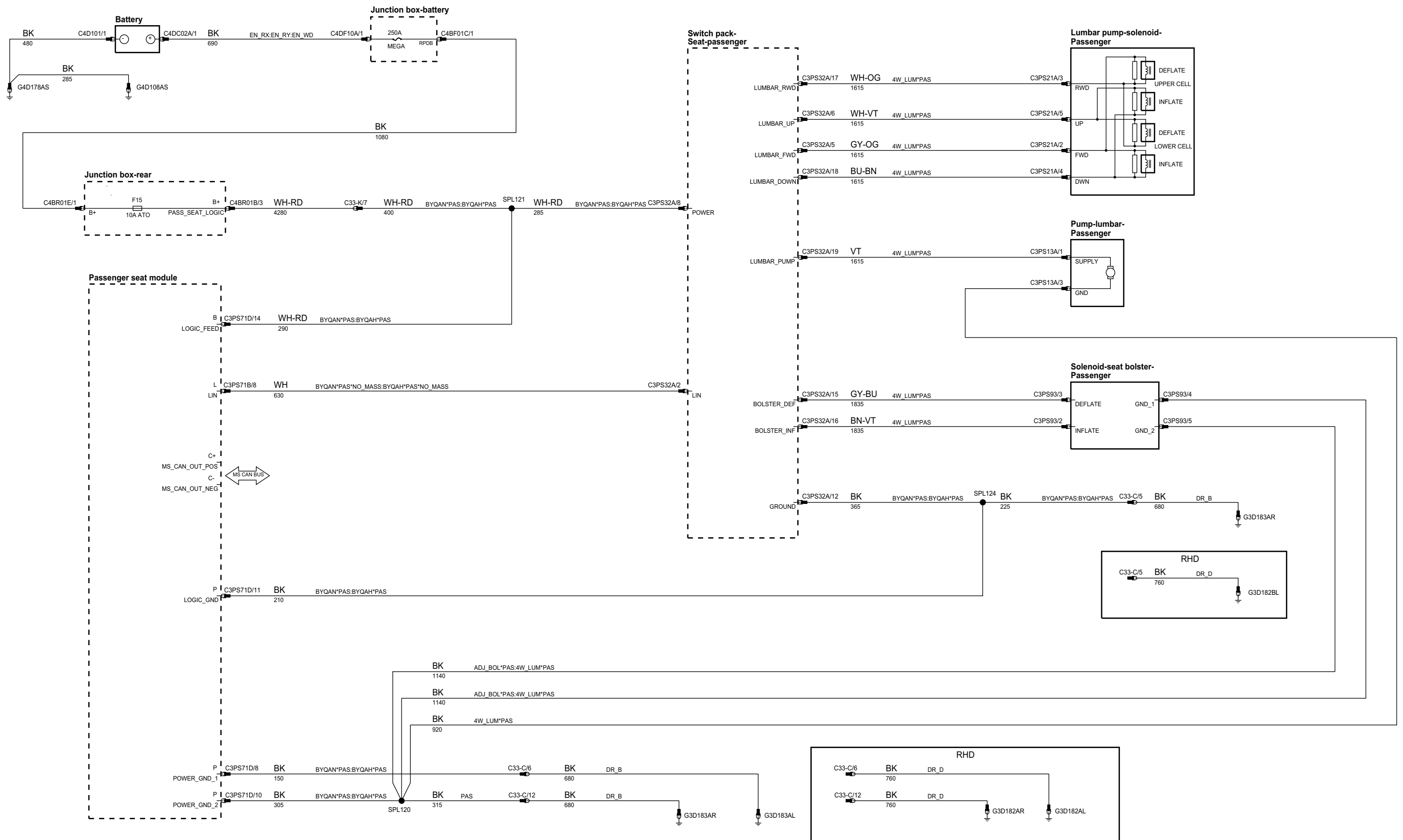

phcw93-70348-d-a3

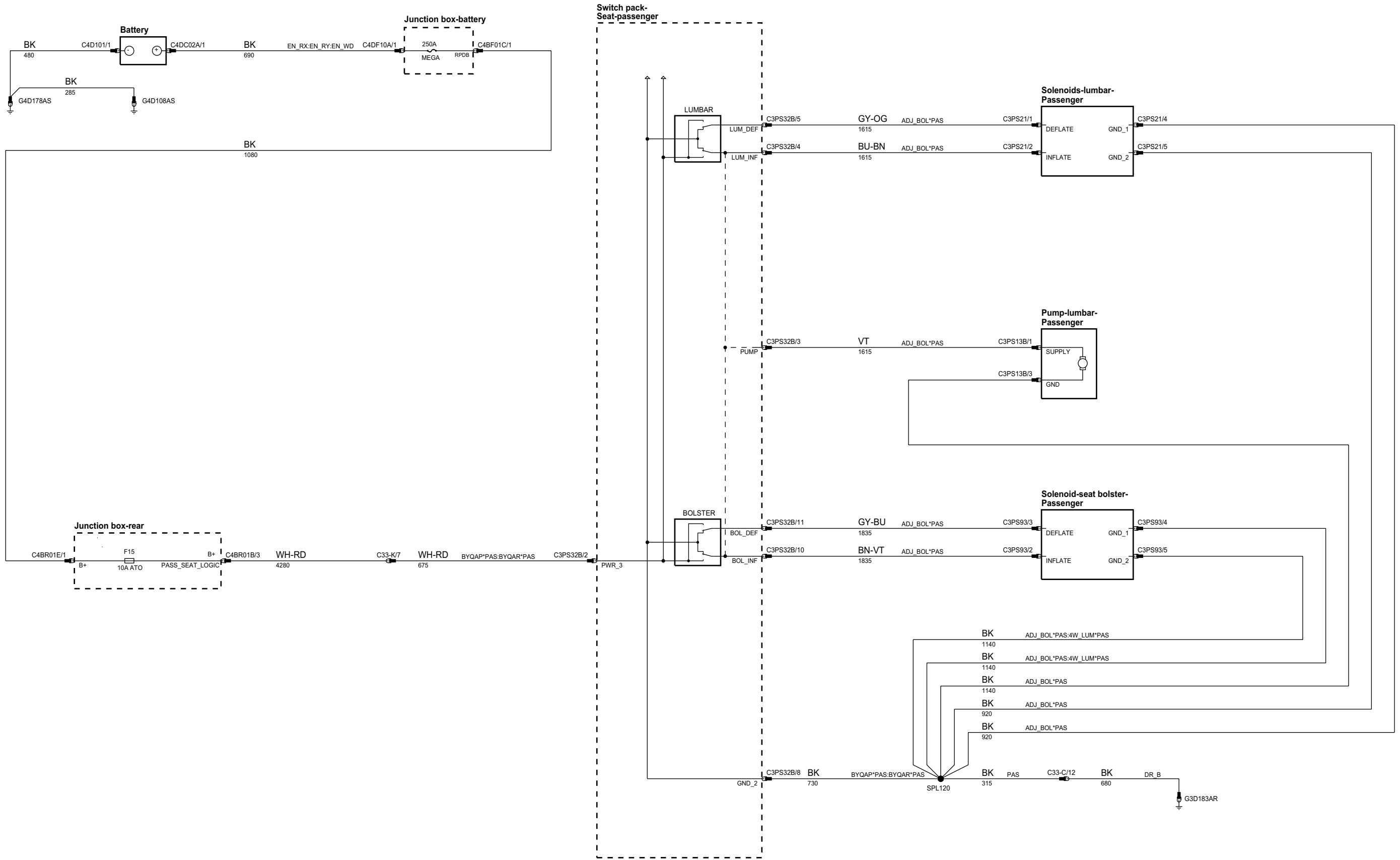

phcw93-70348-h-a3

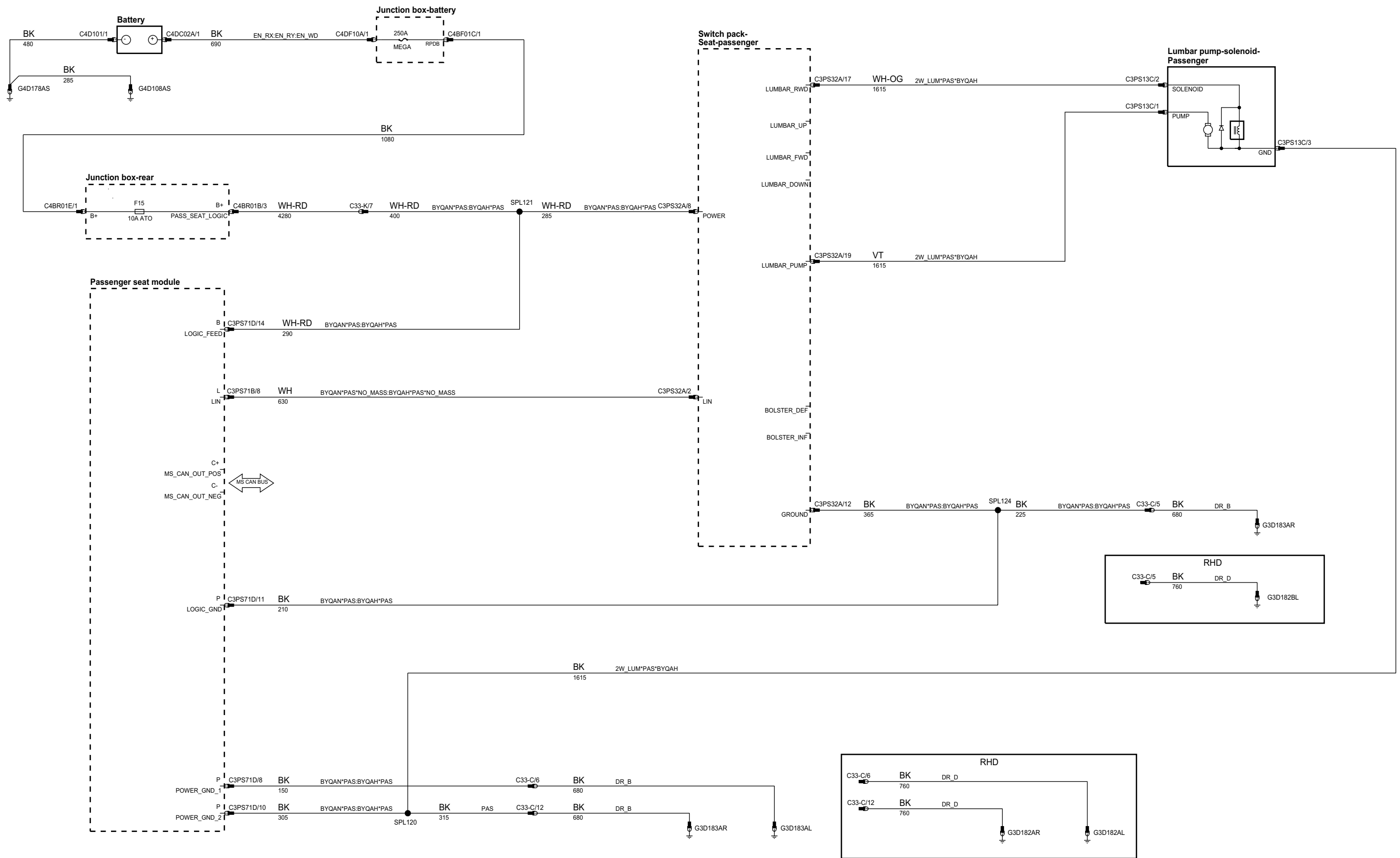

phcw93-70347-d-a3

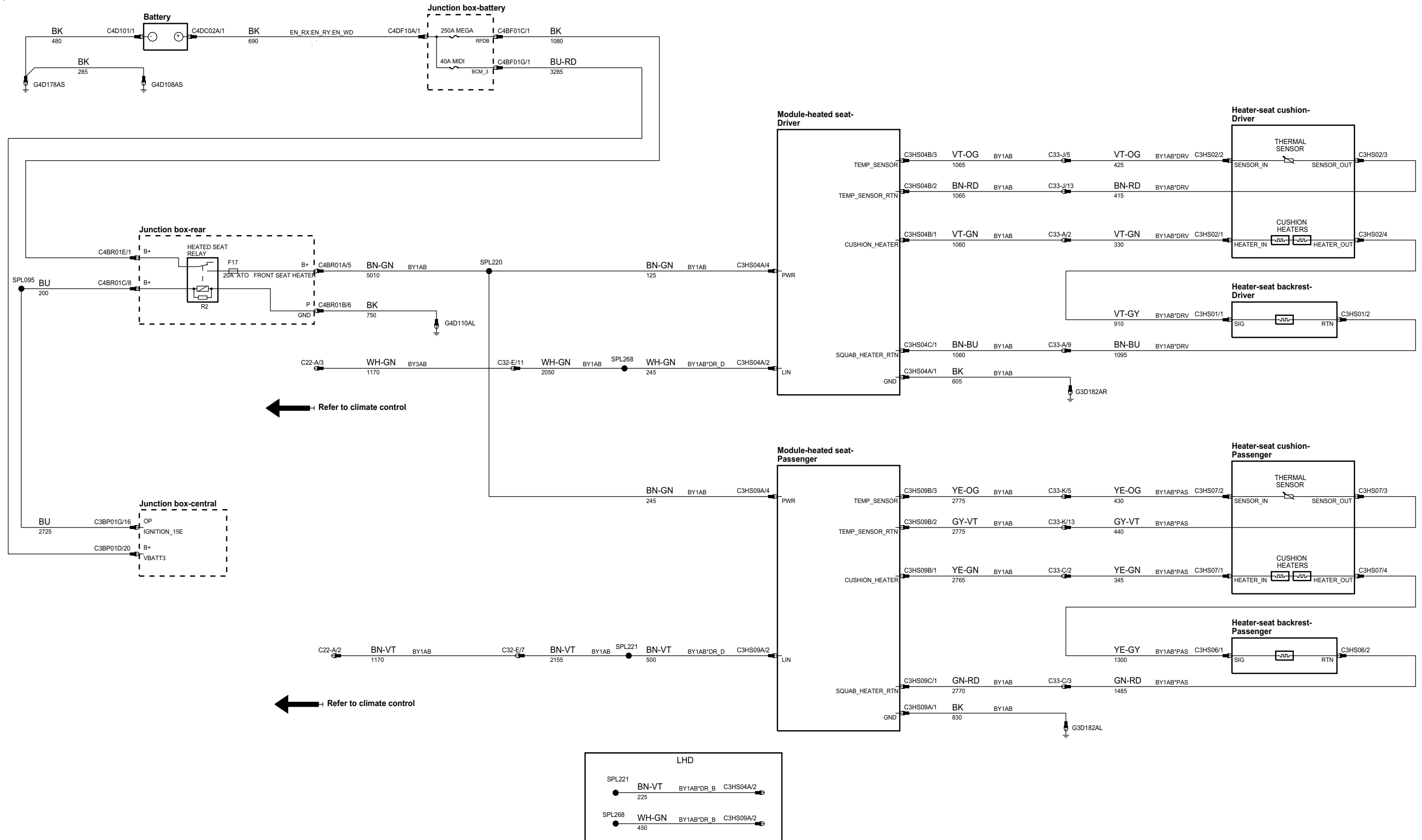

phcw93-70347-a-a3

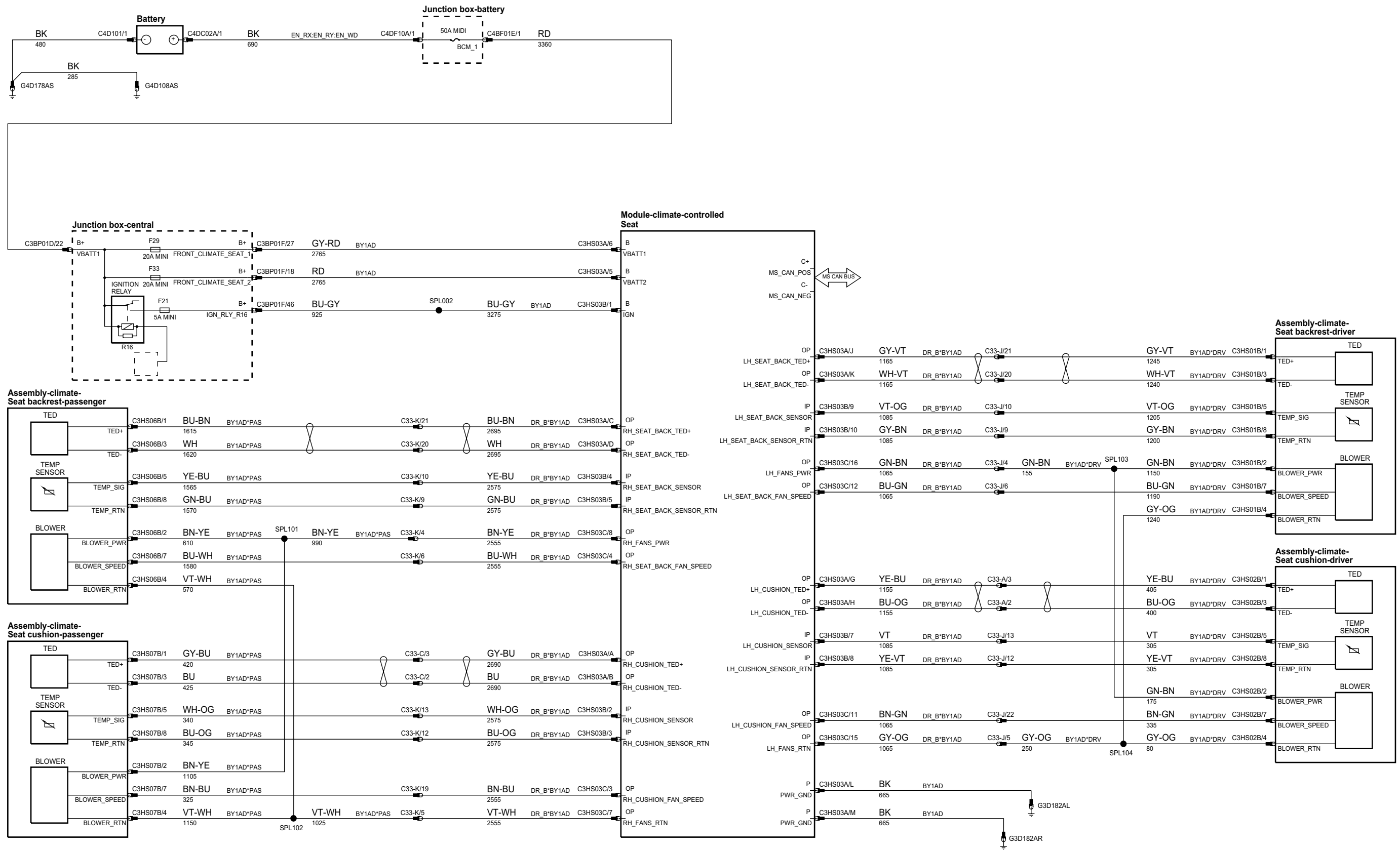

phcw93-70347-b-a3

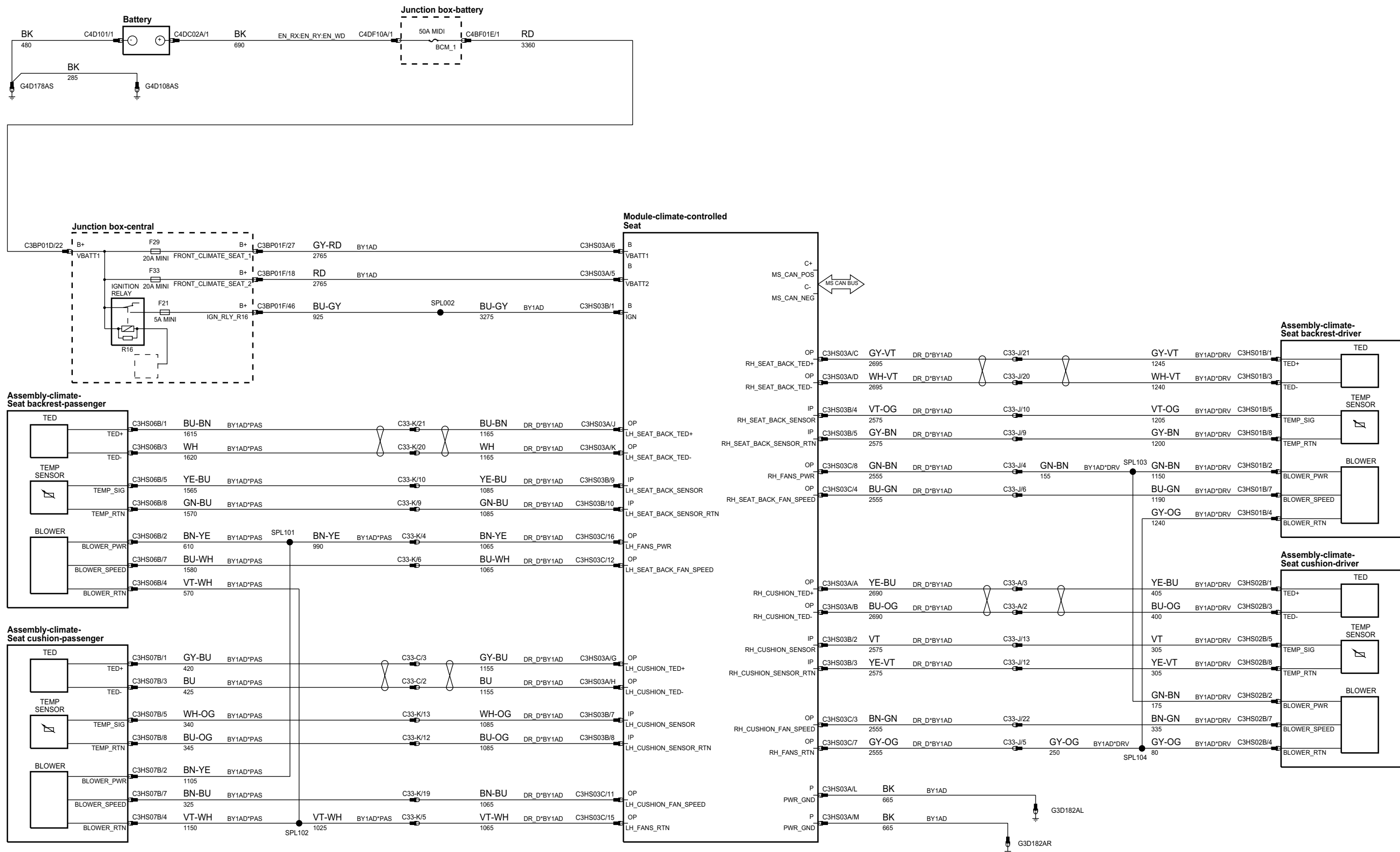

phcw93-70347-c-a3

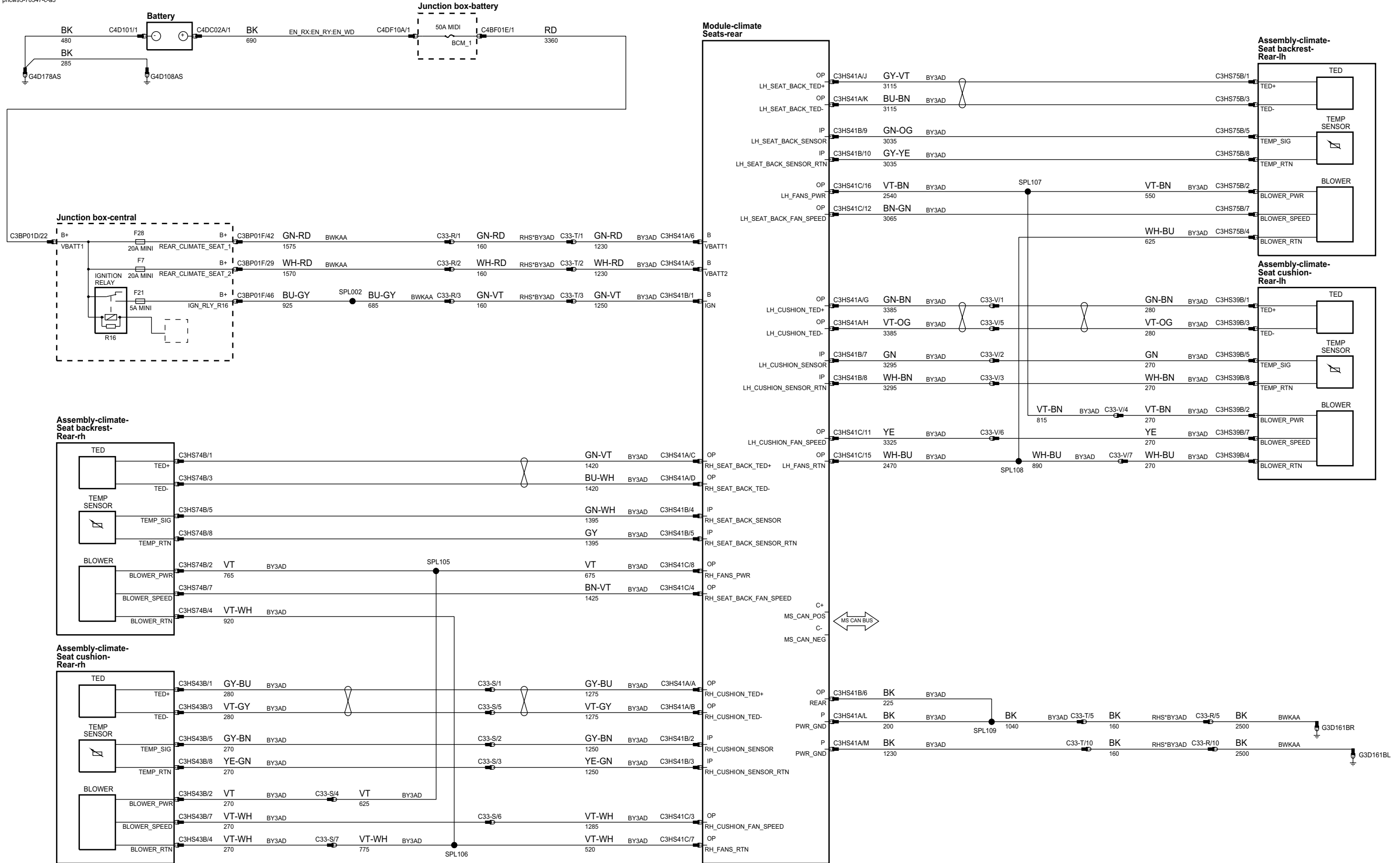

phcw93-70347-f-a3

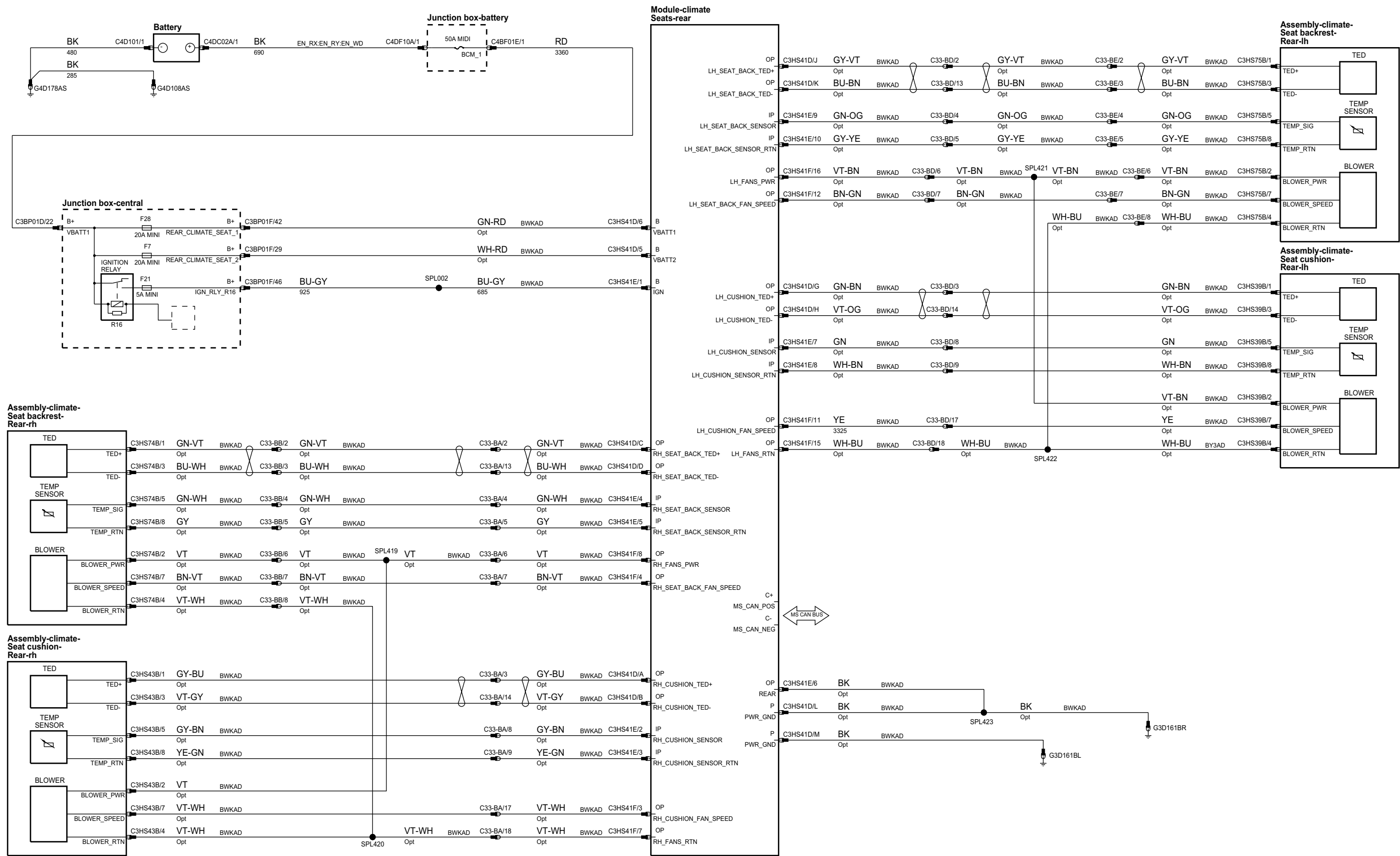

phcw93-70347-e-a3

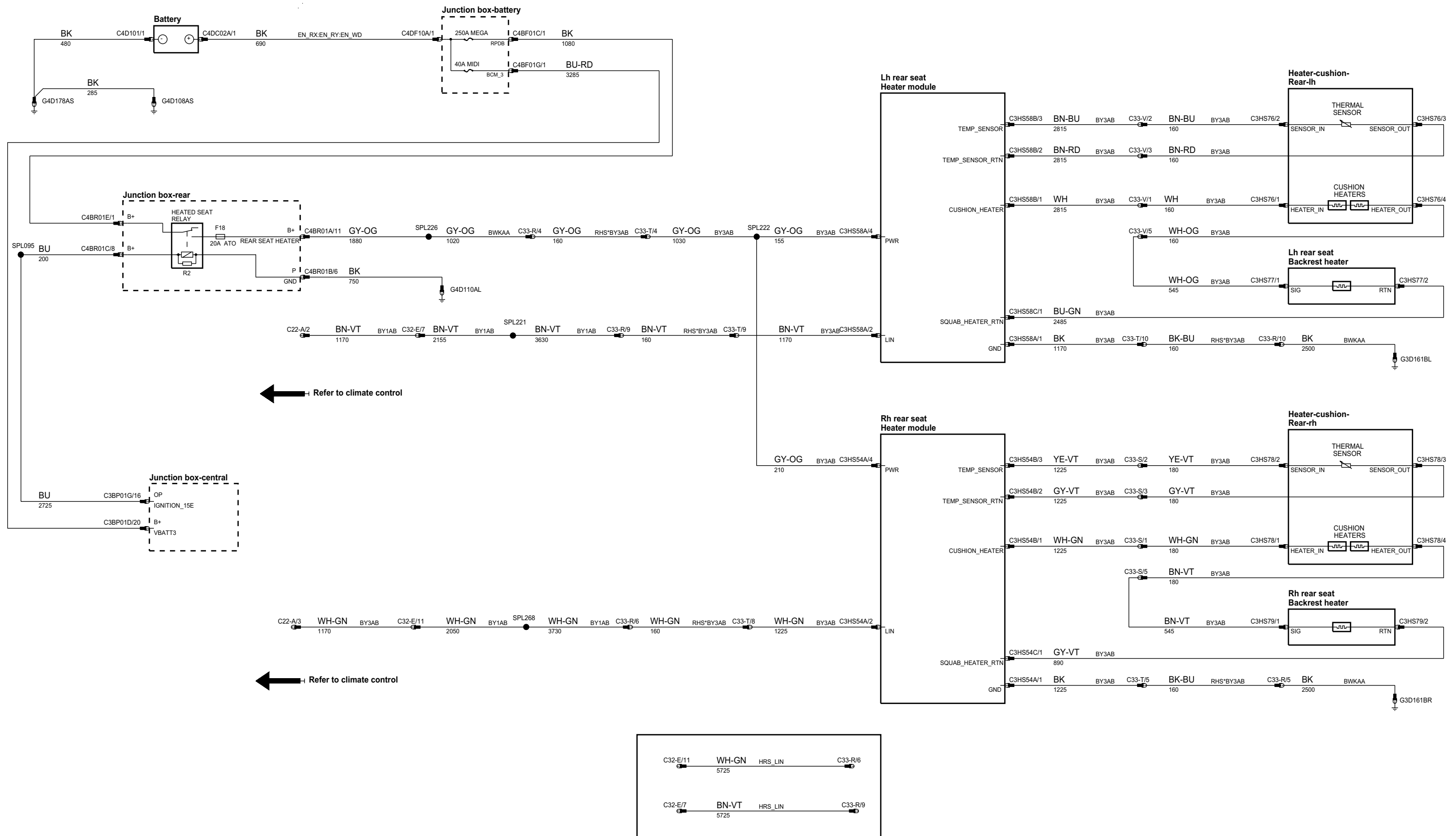

phcw93-70348-e-a3

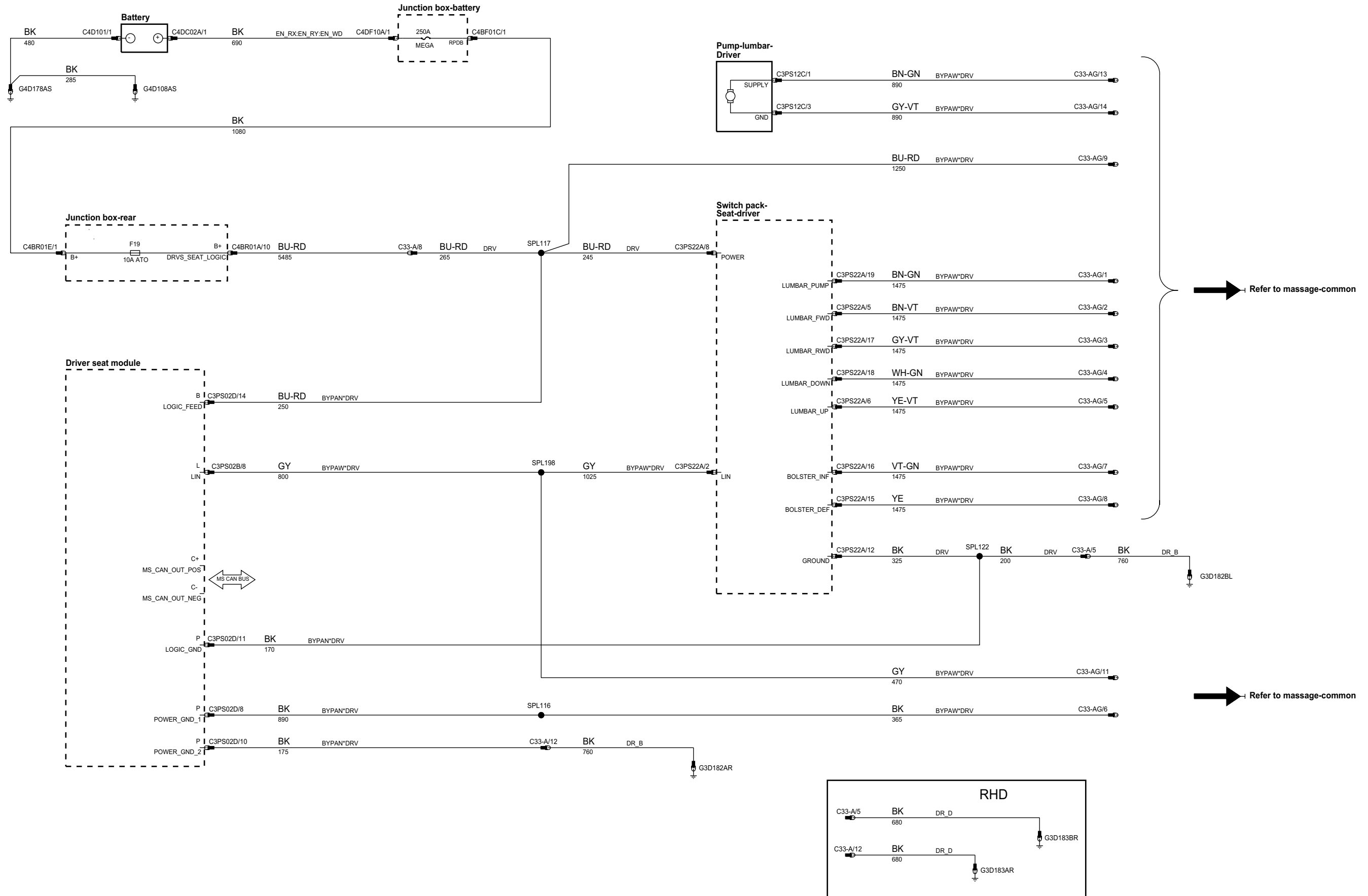

phcw93-70348-f-a3

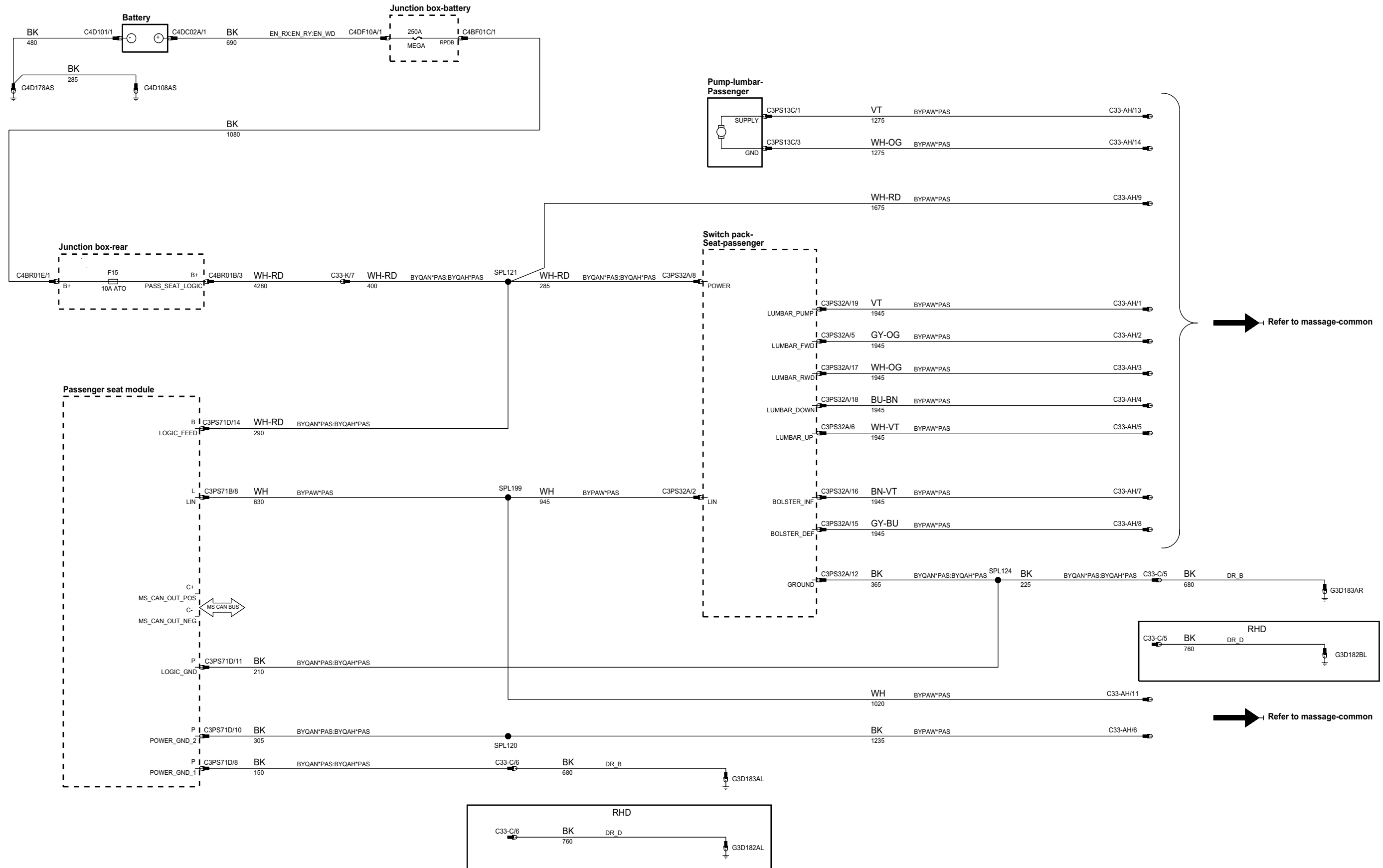

Refer to massage-common

Refer to massage-common

phcw93-70348-g-a3

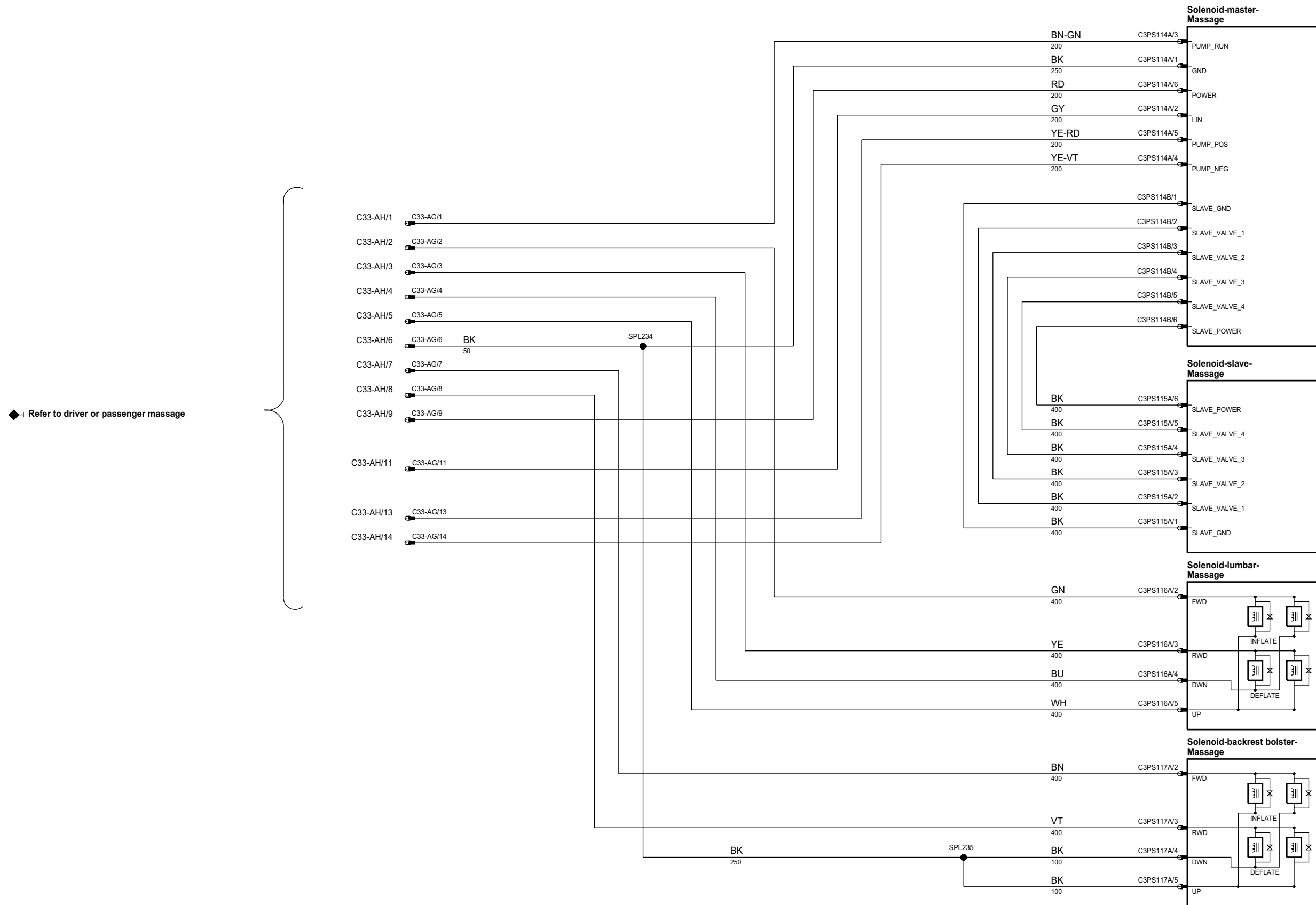

phcw93-70349-a-a3

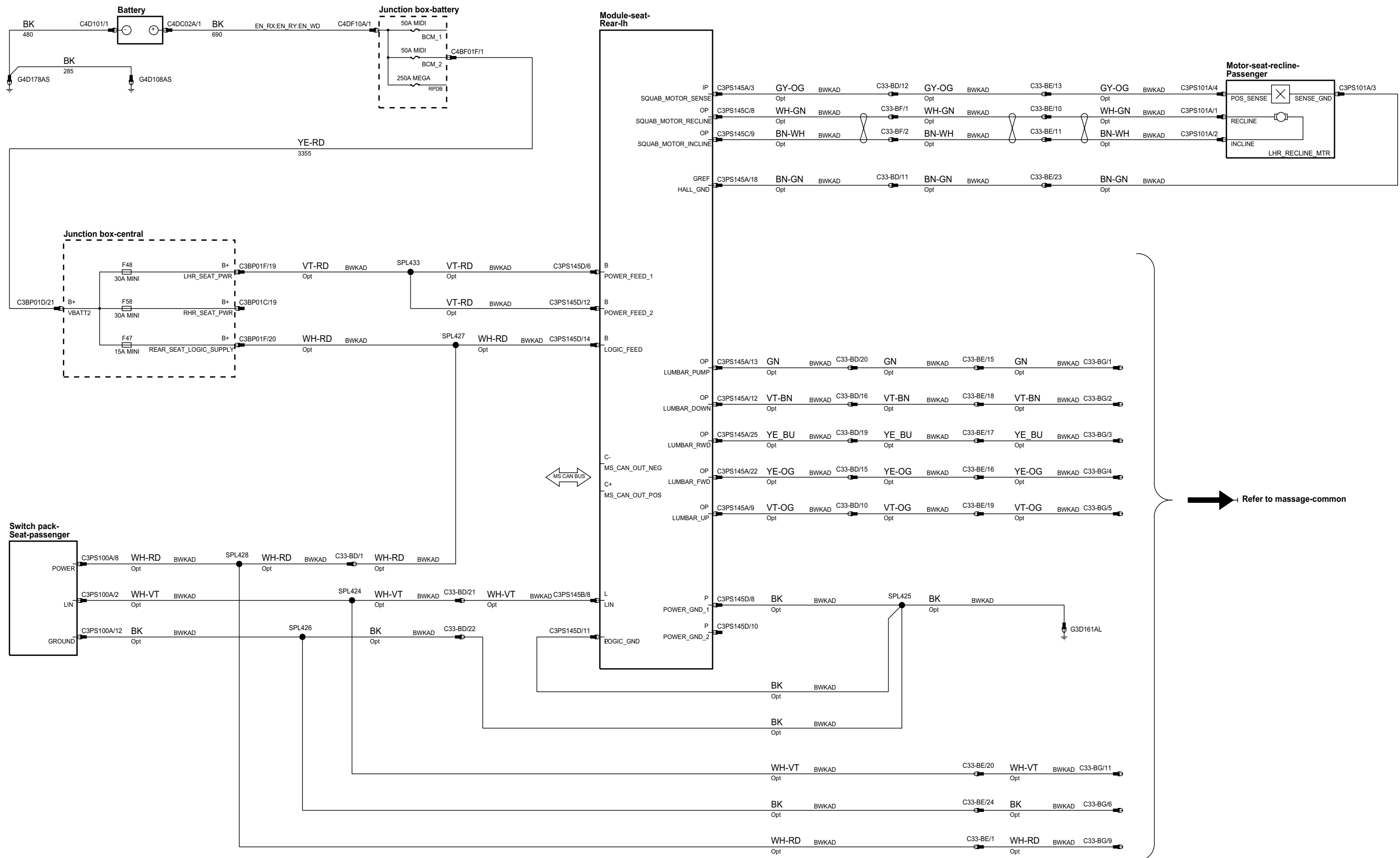

phcw93-70349-b-a3

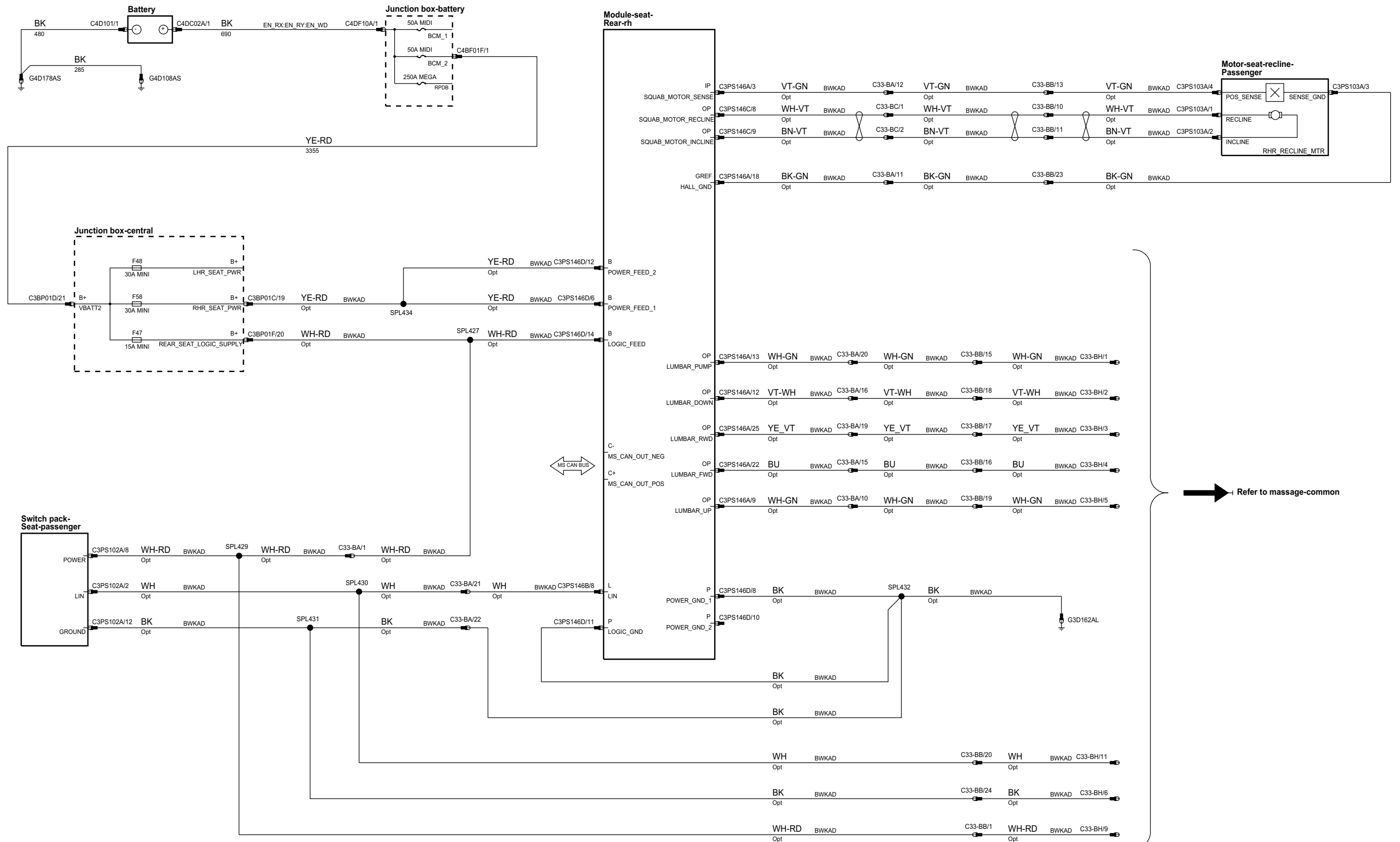

phw93-70349-c-a3

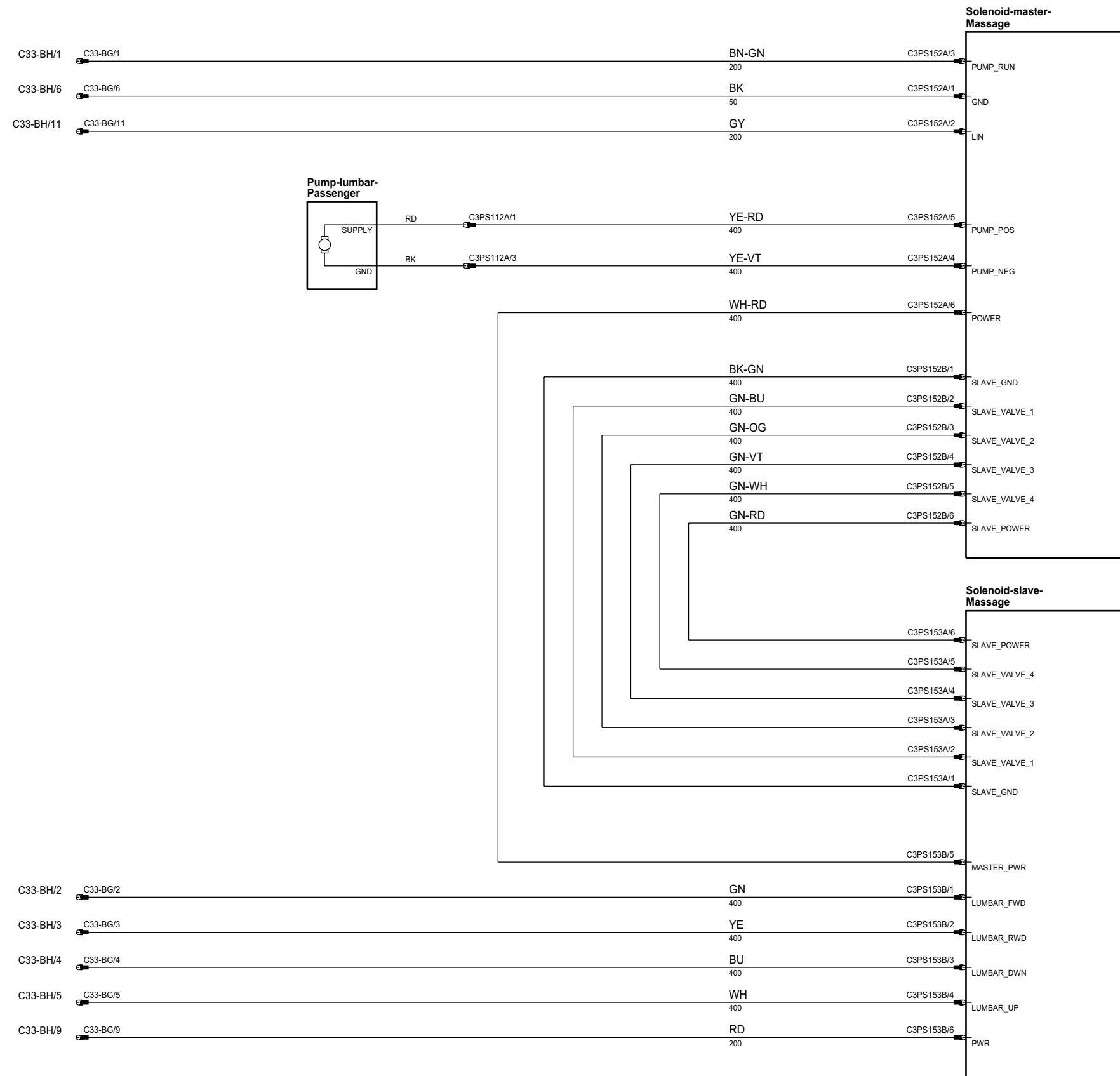

Refer to lh rear
Or rh rear massage

phcw93-70316-a-a3

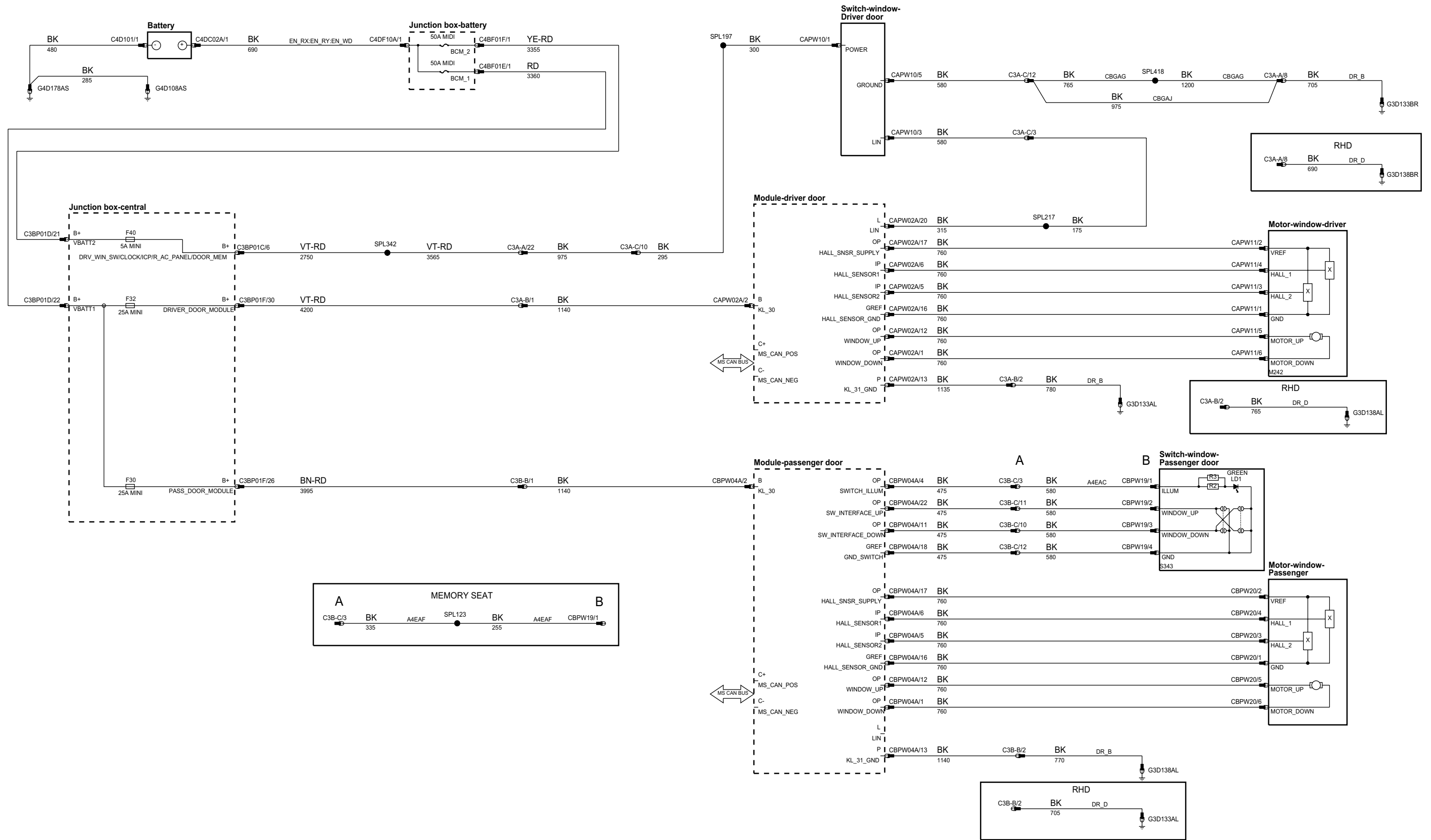

phcw93-70316-b-a3

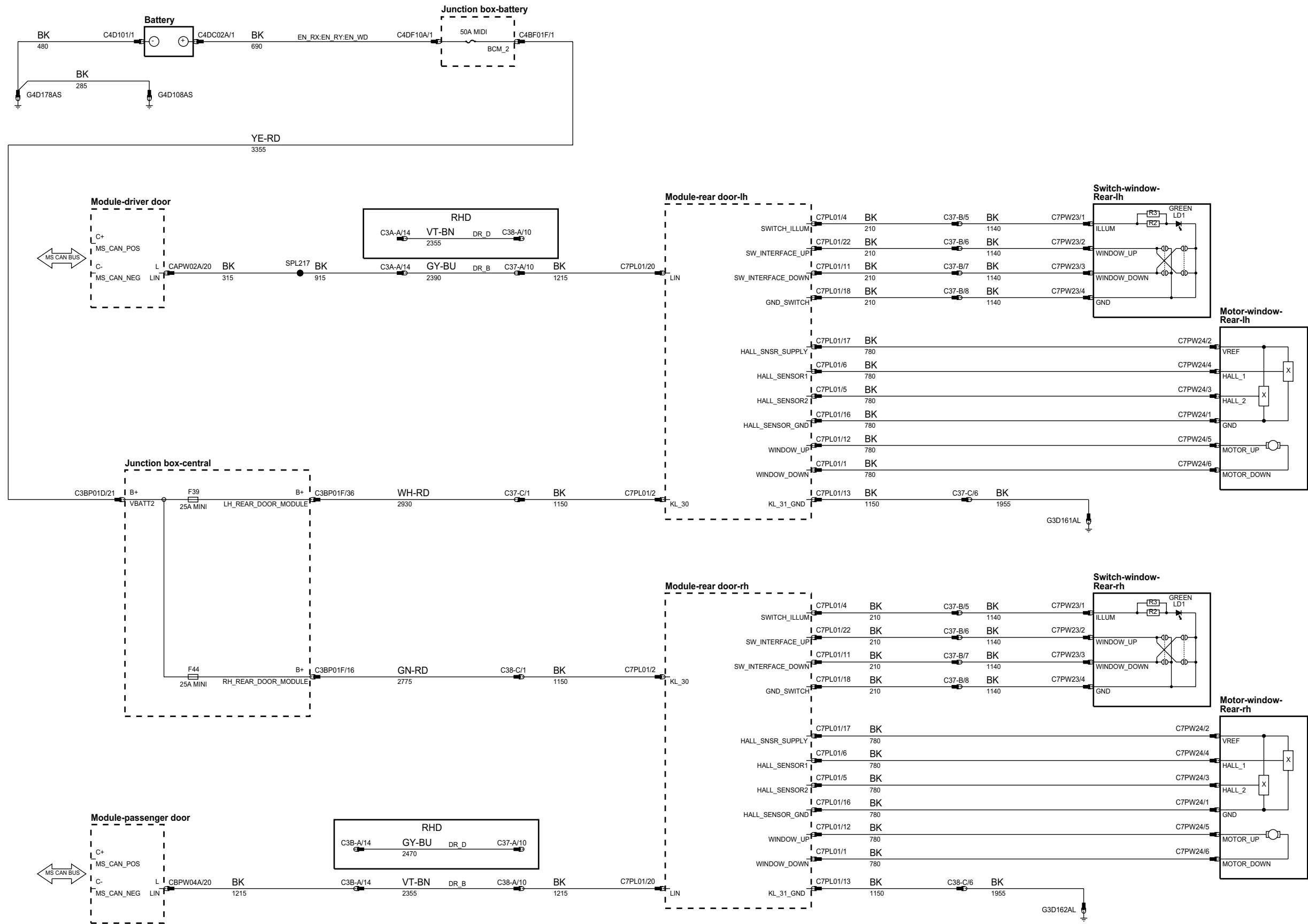

phcw93-70317-b-a3

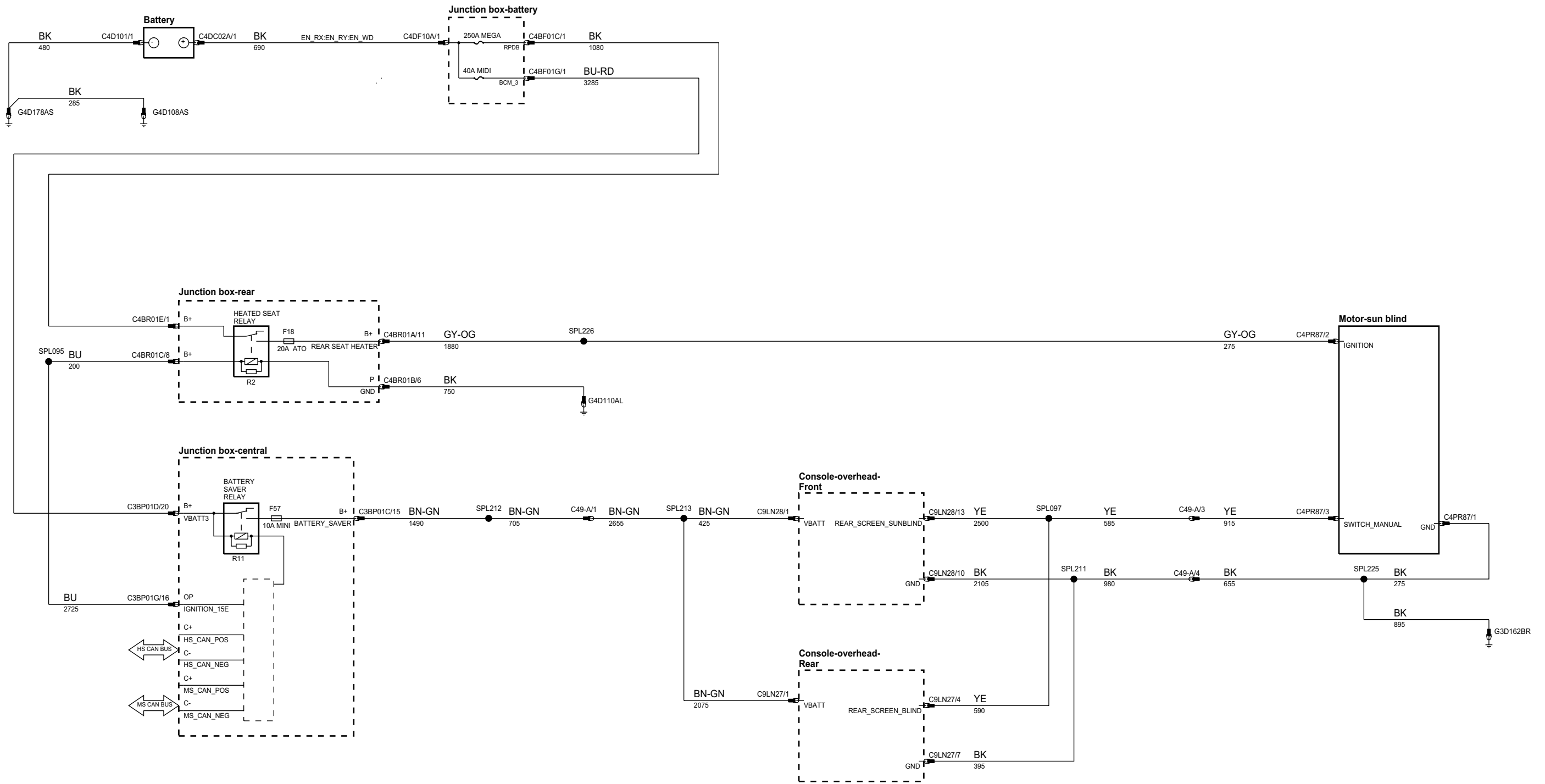

phcw93-70210-a-a3

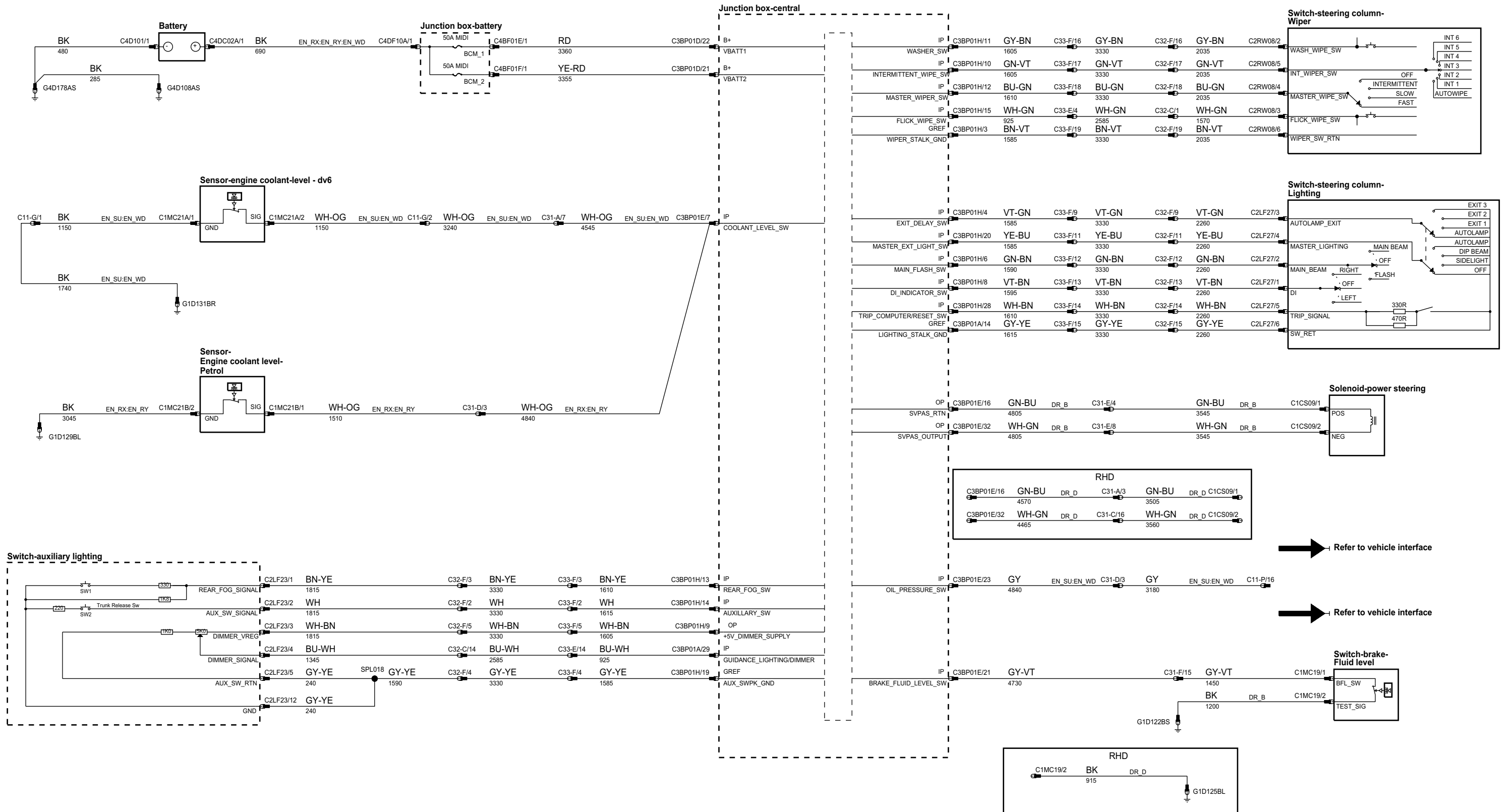

➔ Refer to vehicle interface

➔ Refer to vehicle interface

phcw93-70210-c-a3

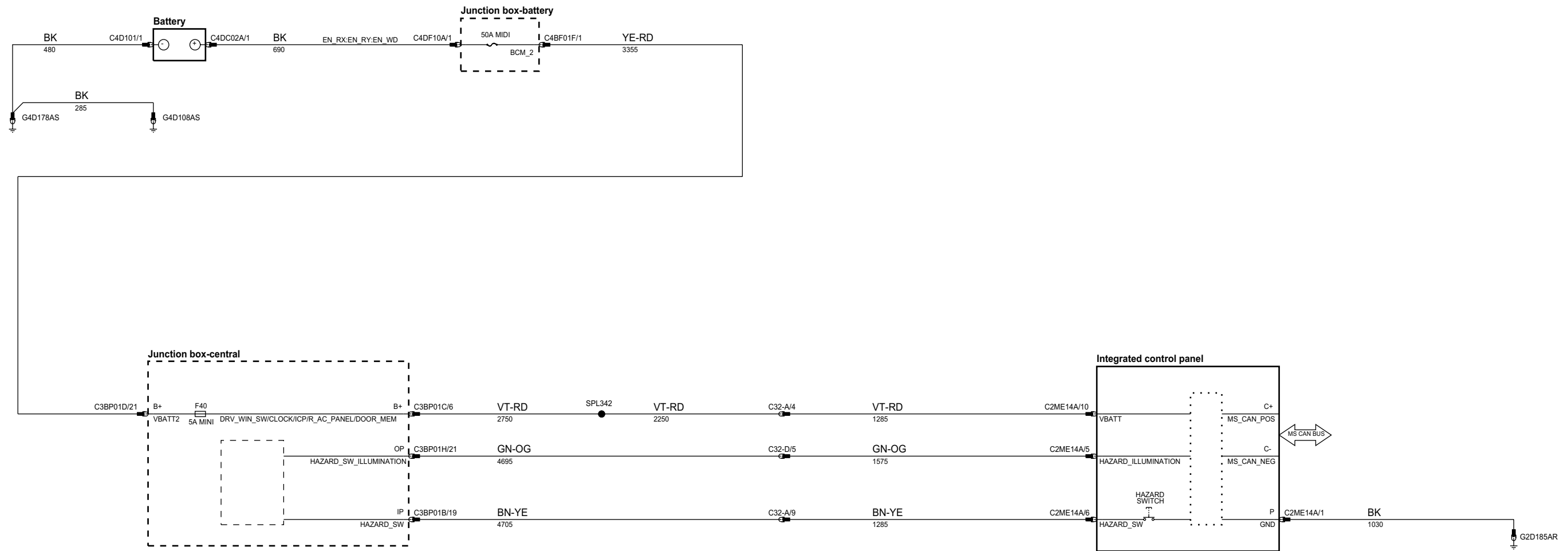

phcw93-70365-a-a3

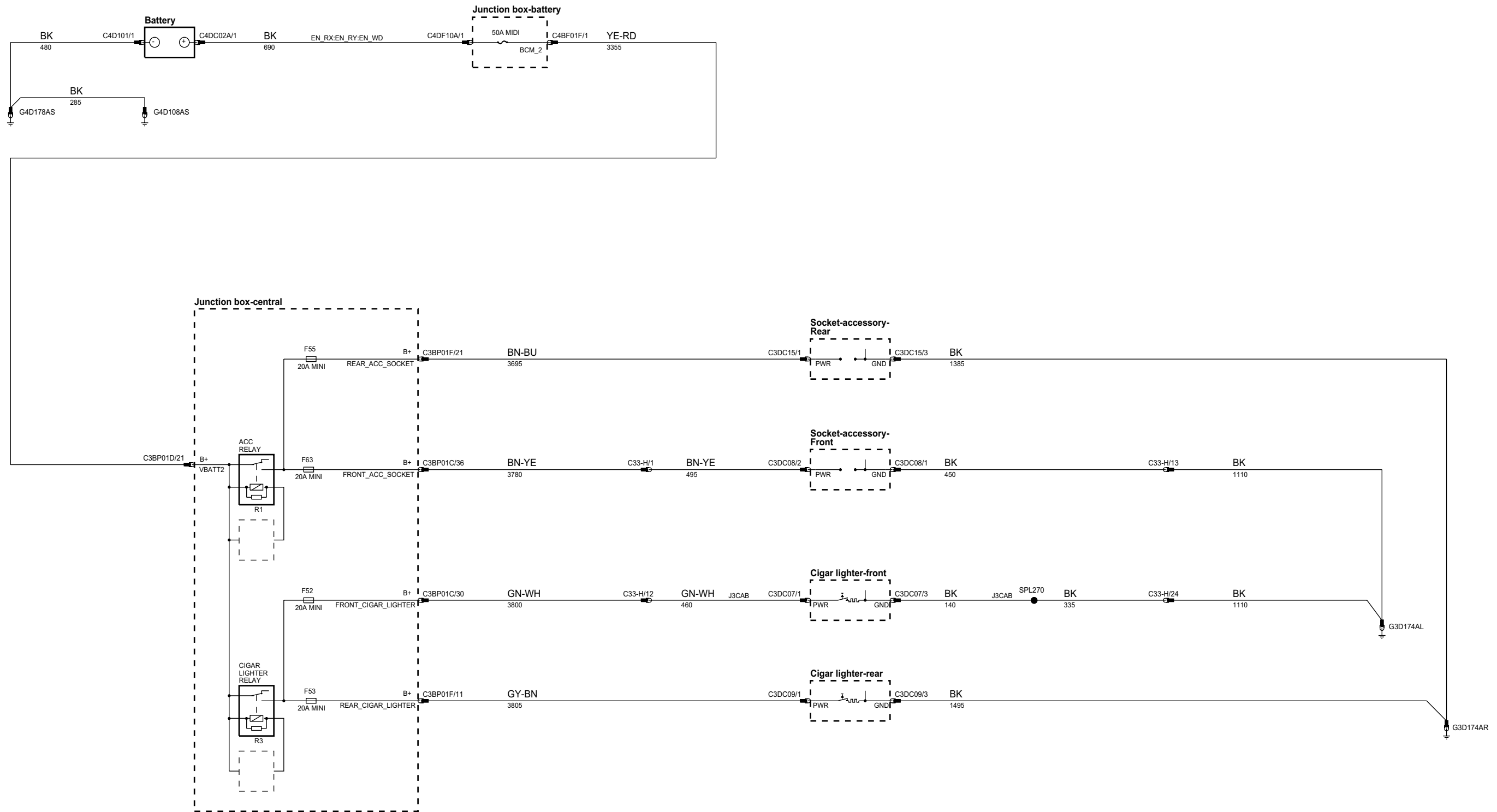

phcw93-70417-a-a3

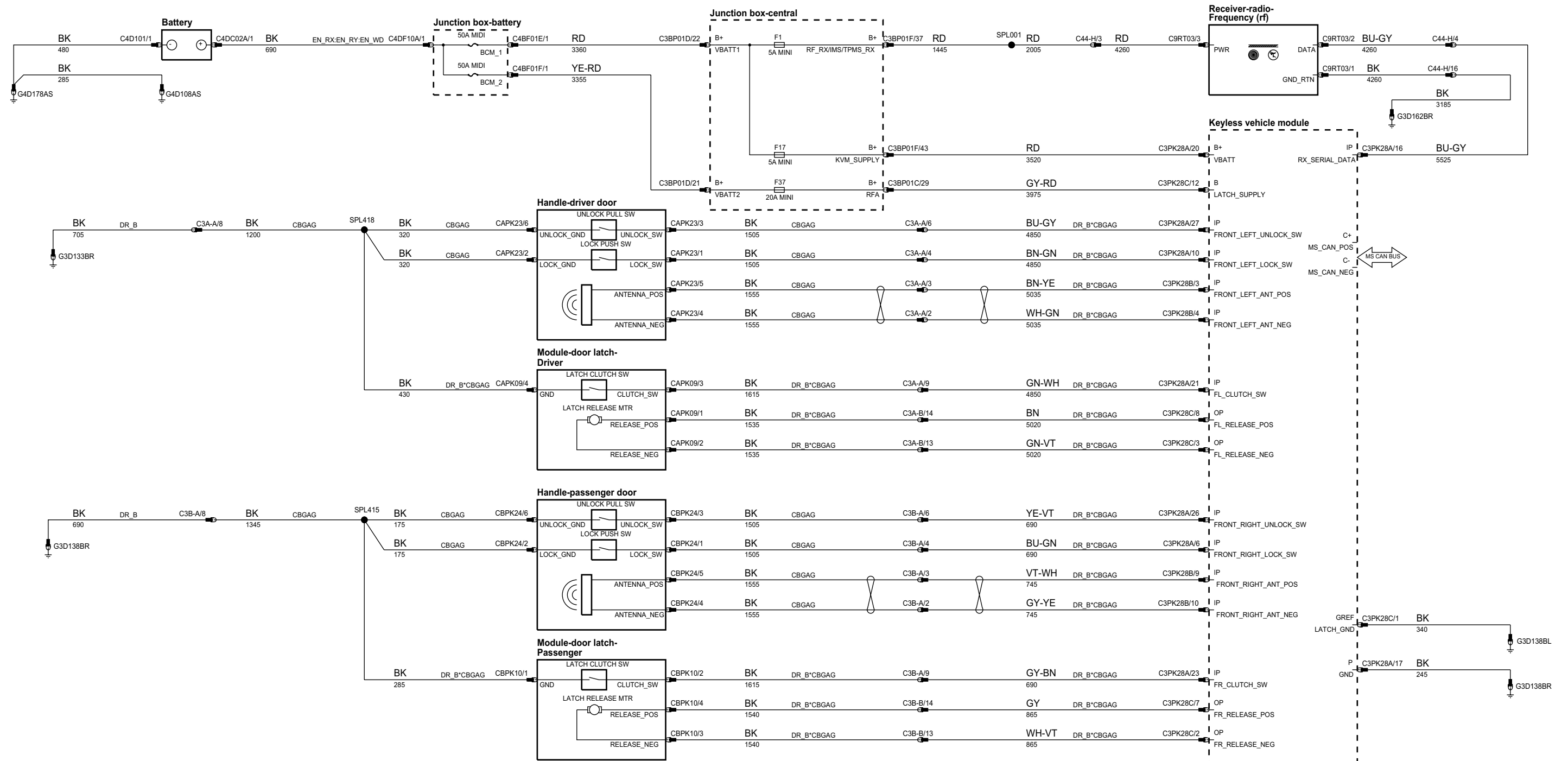

phcw93-70417-c-a3

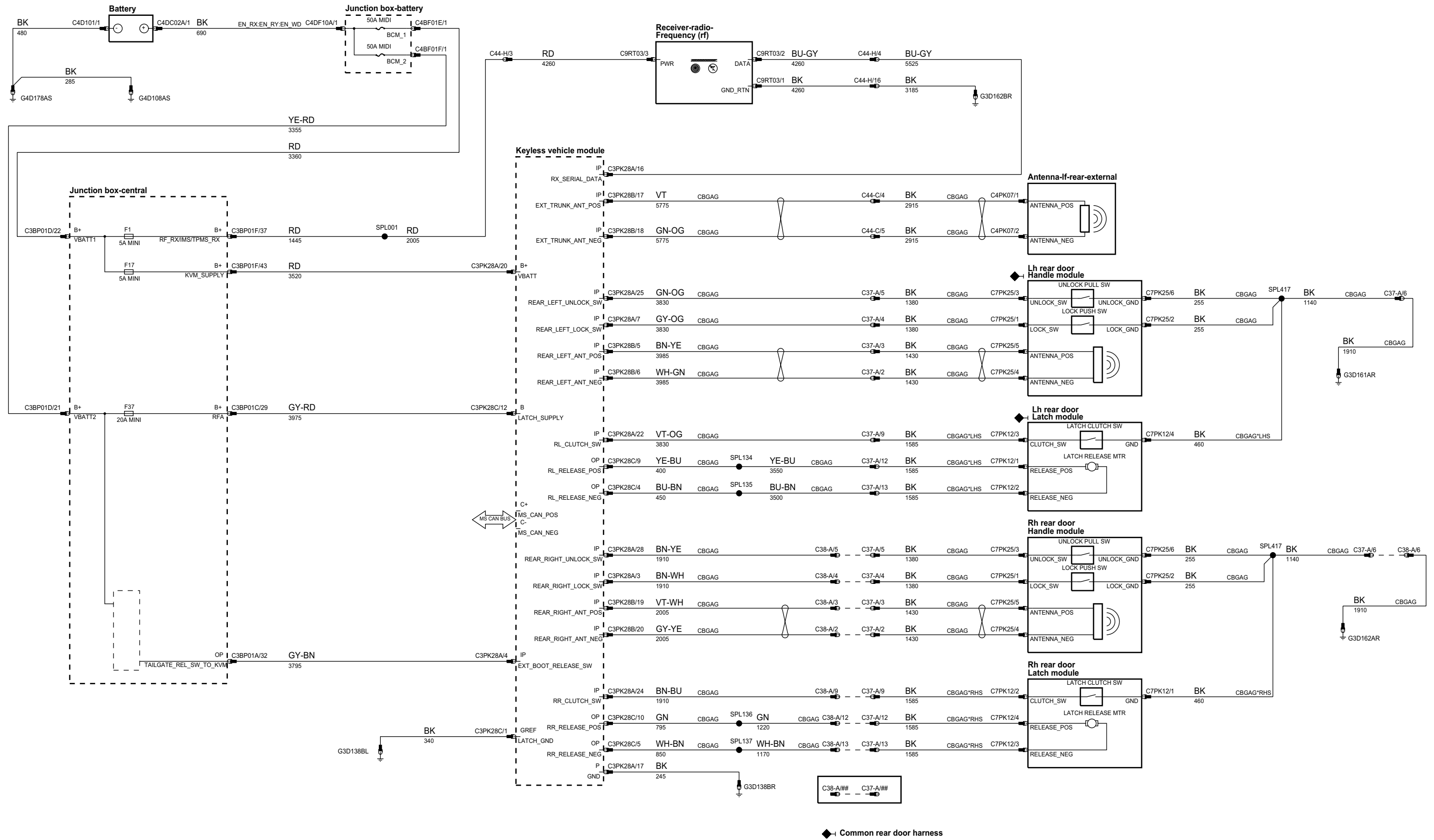

phcw93-70421-a-a3

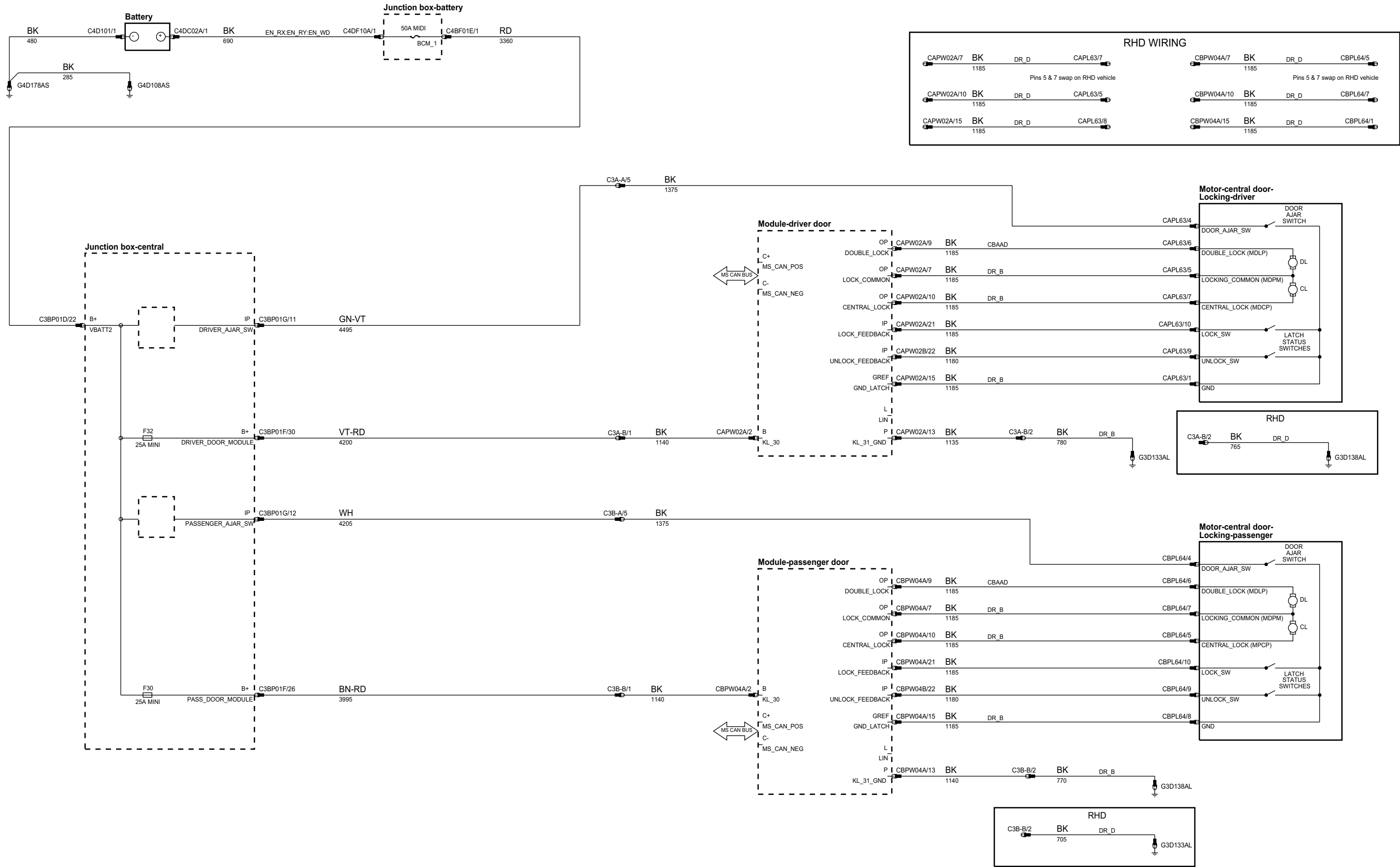

phcw93-70421-d-a3

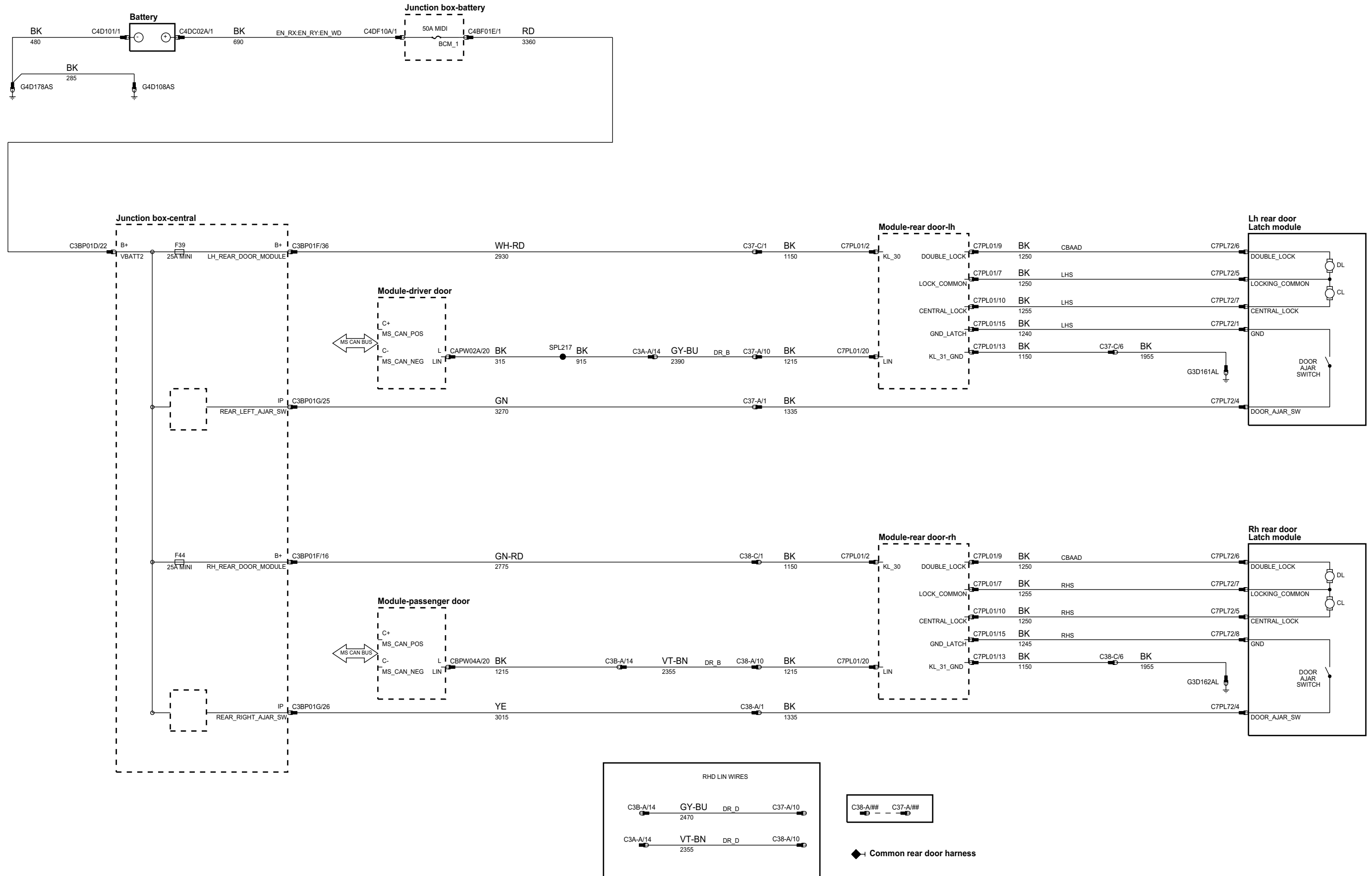

phow93-70421-b-a3

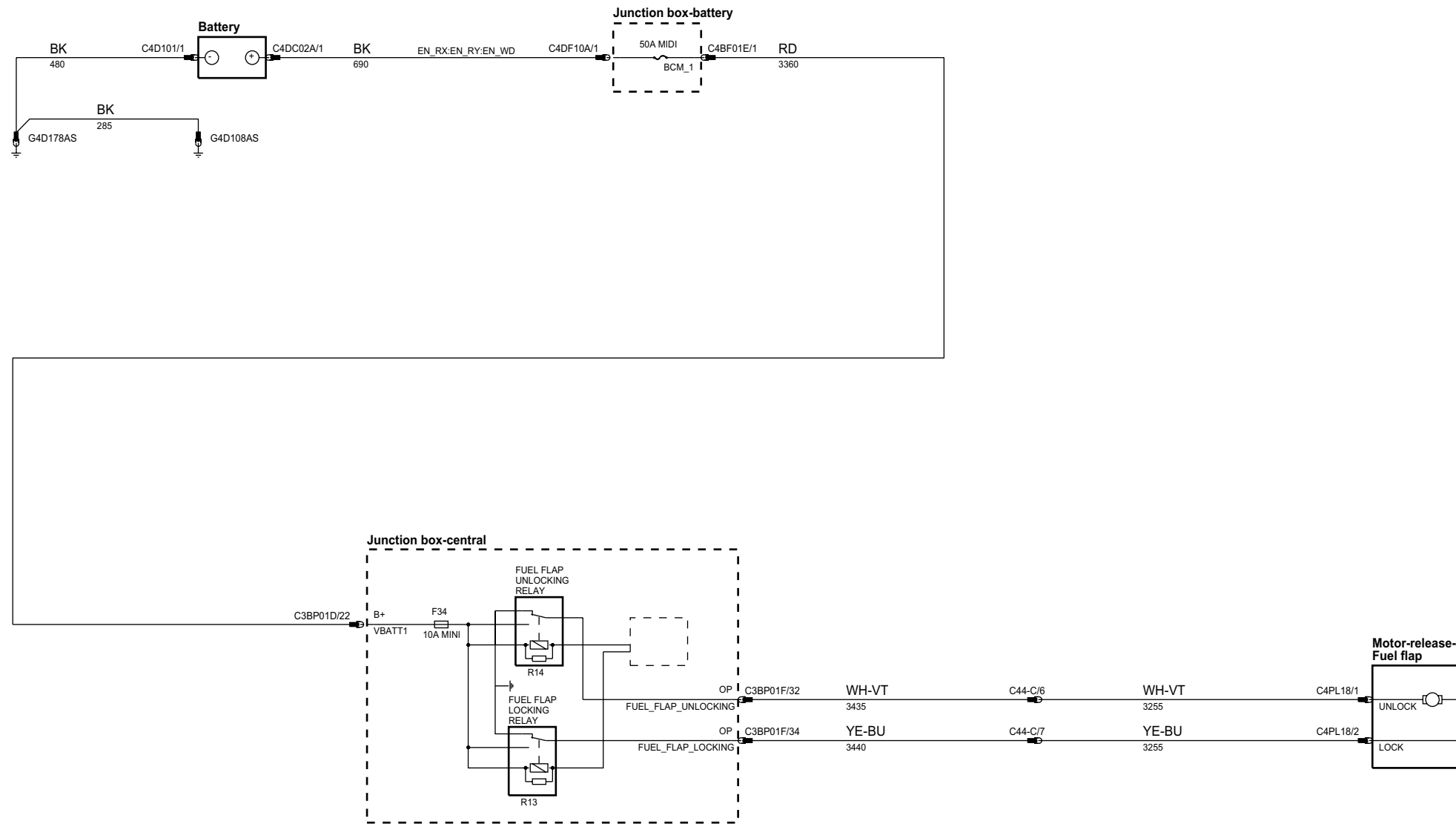

x

phcw93-70354-a-a3

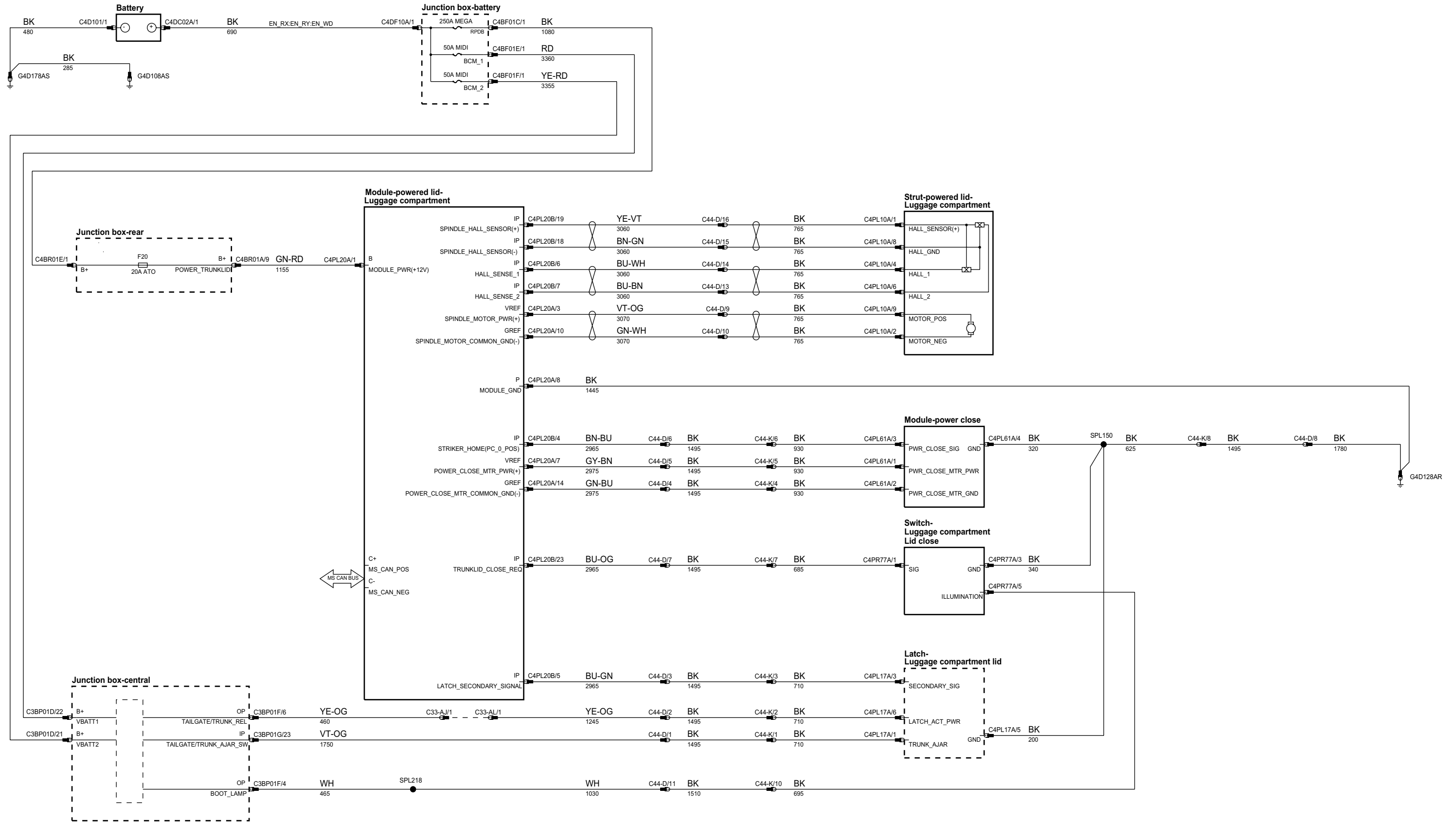

phcw93-70354-b-a3

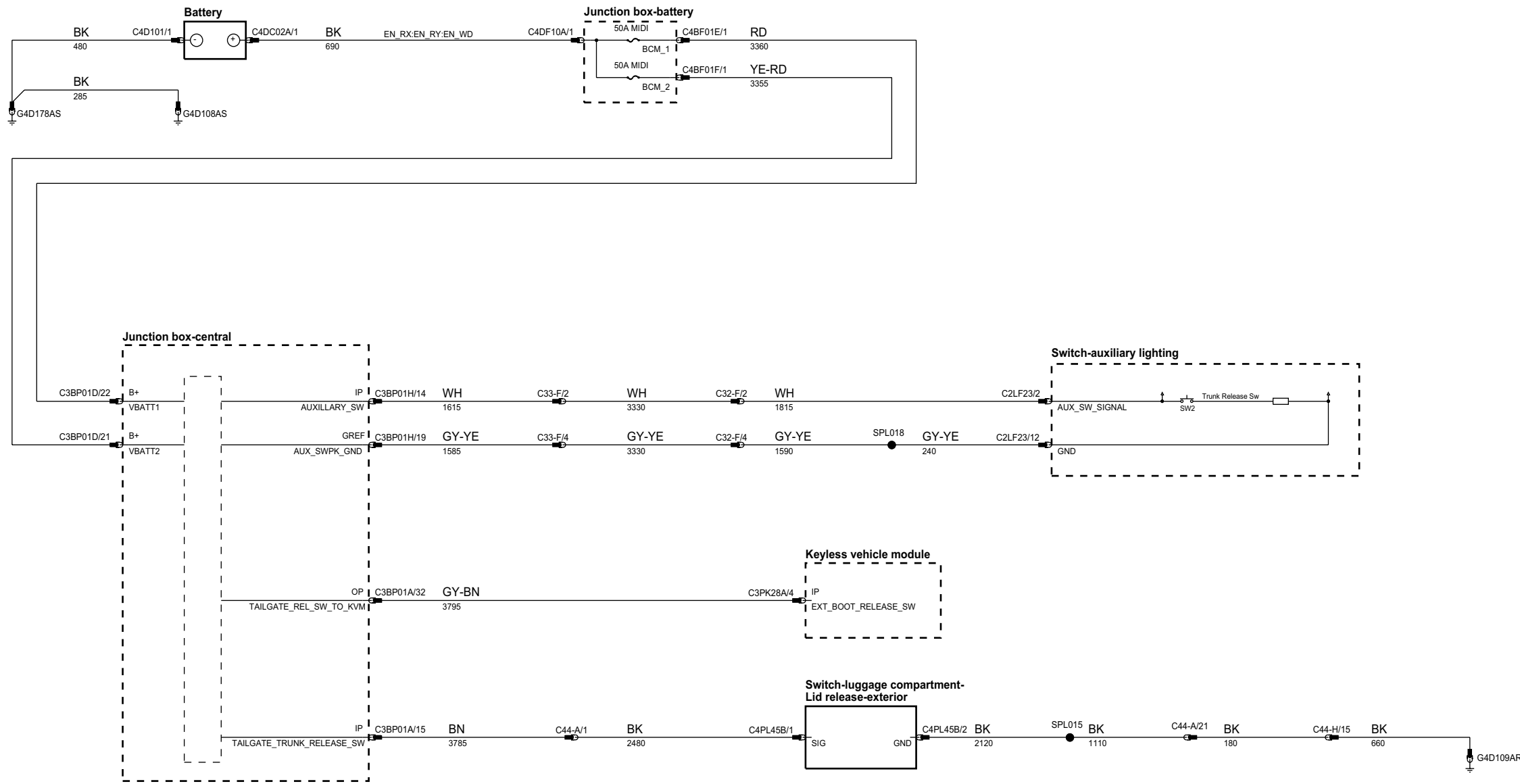

x

phcw93-70133-a-a3

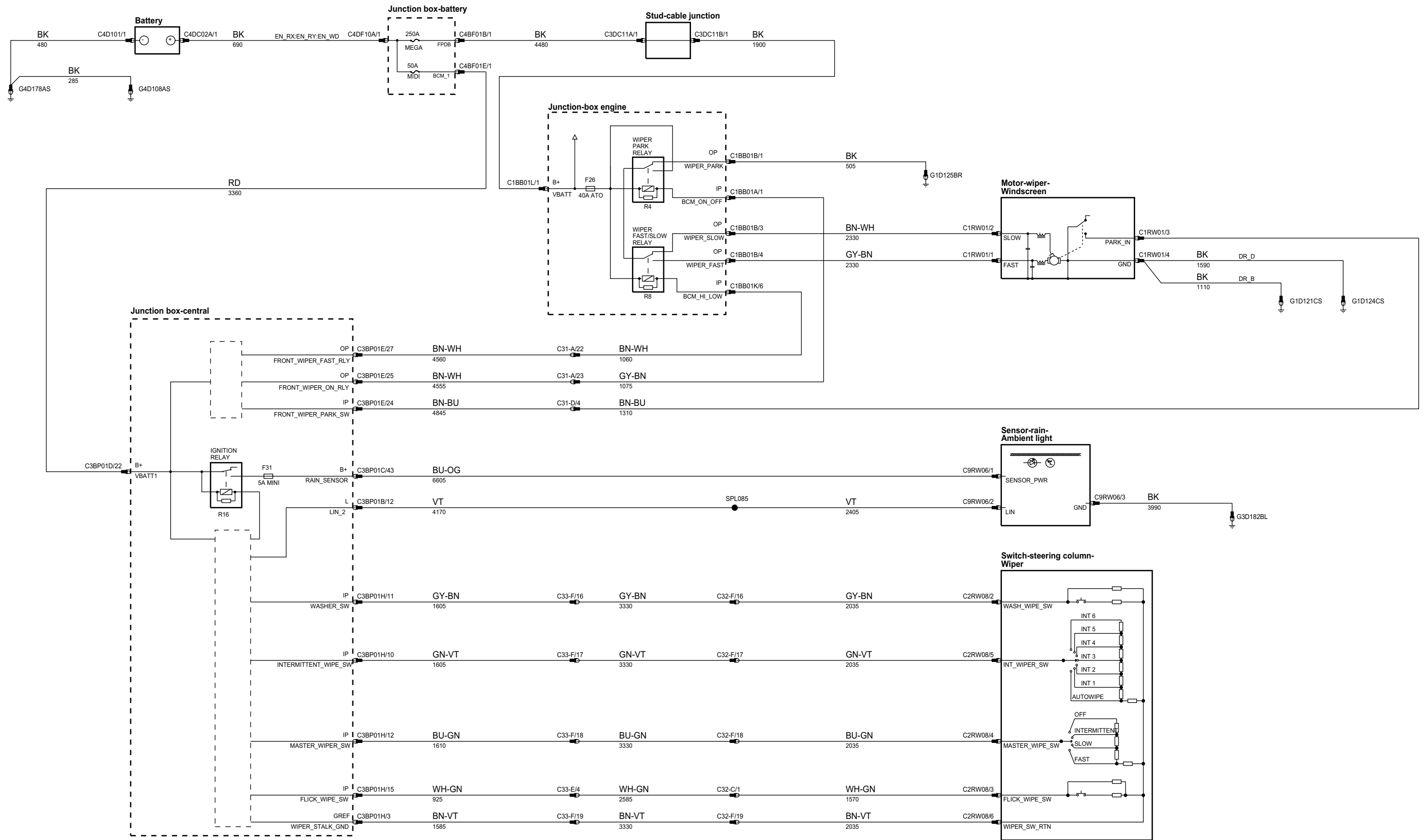

phcw93-70133-b-a3

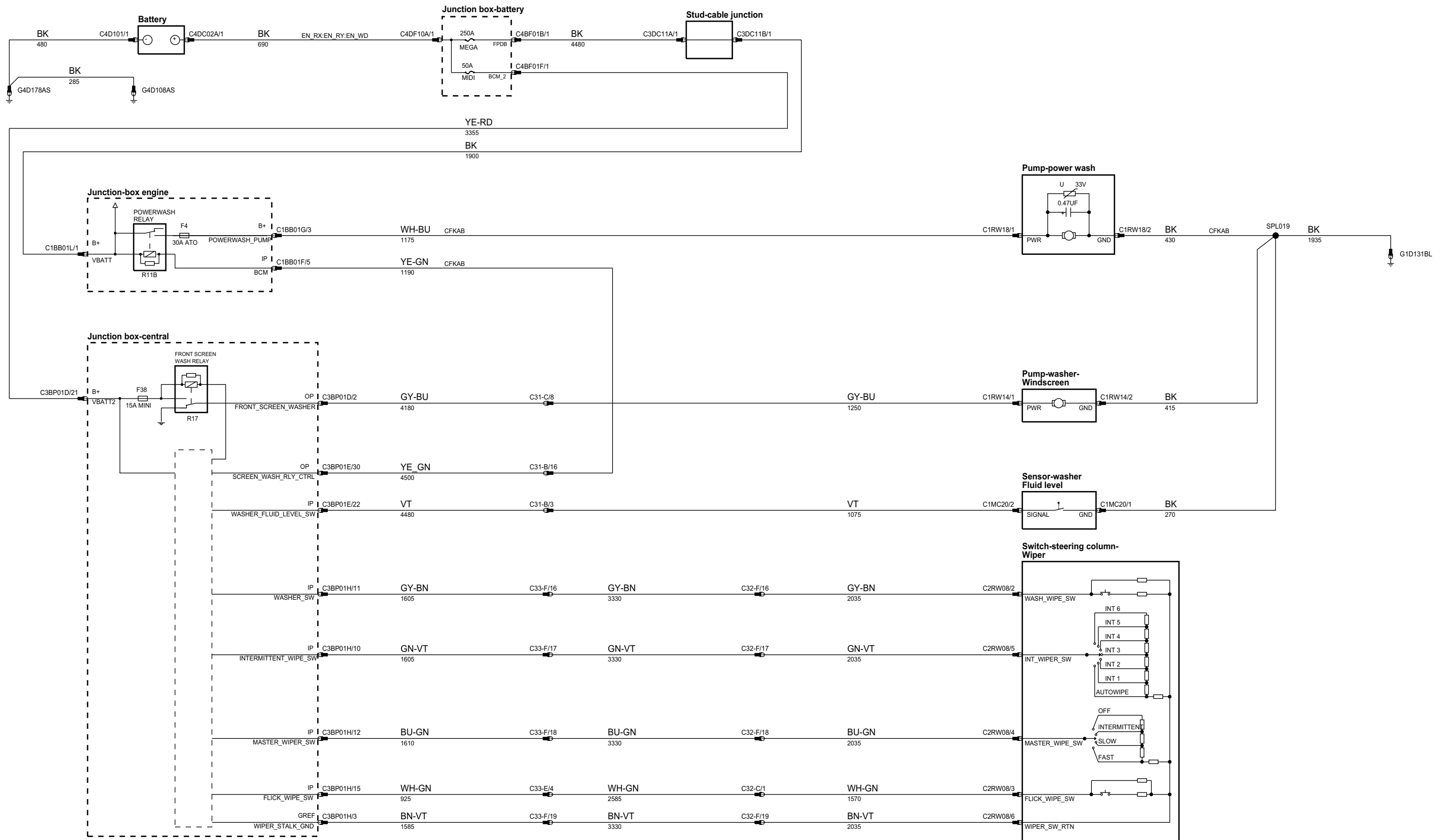

phcw93-70317-a-a3

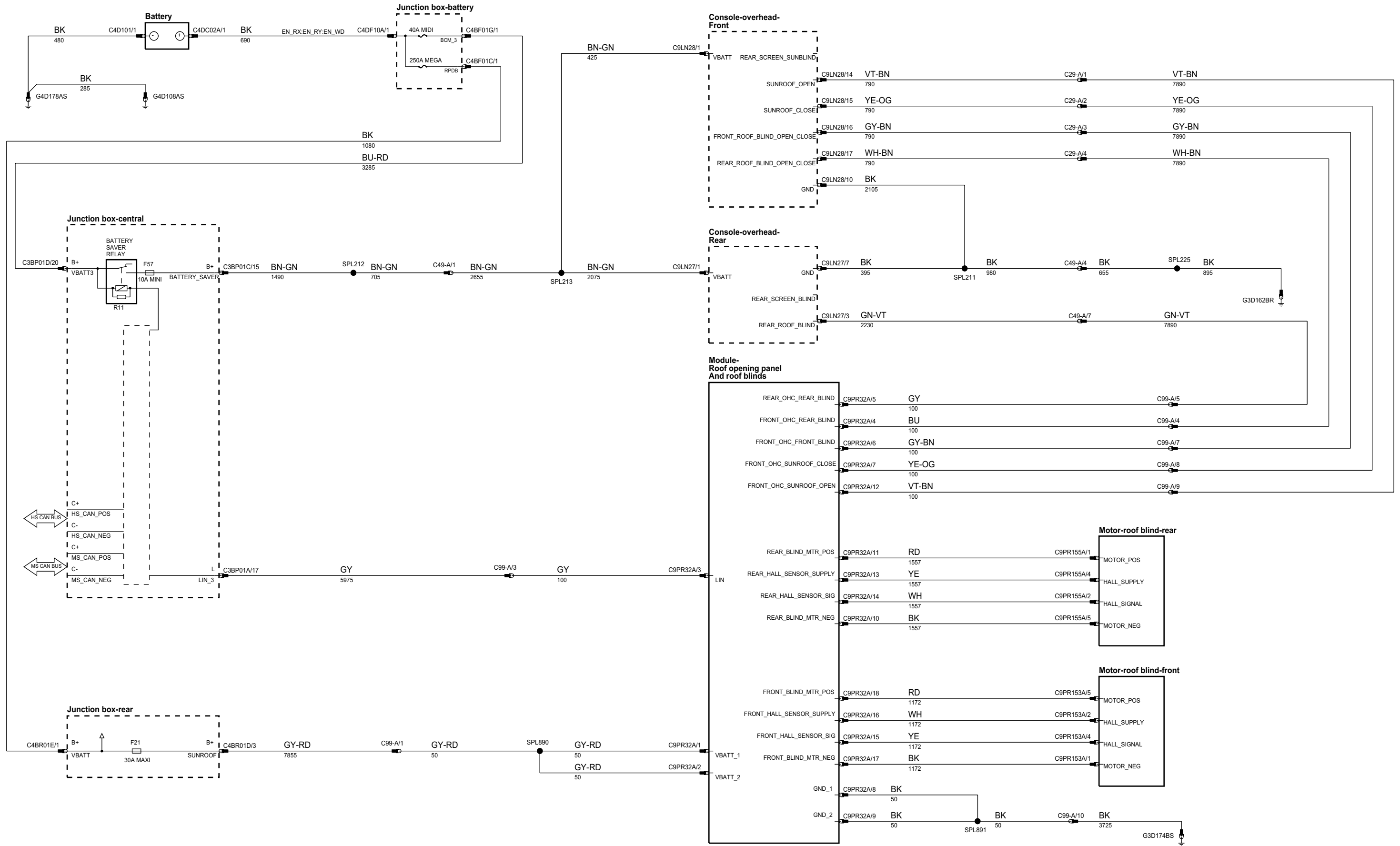

501-20A - SAFETY BELT SYSTEM

phcw93-70150-c-a3

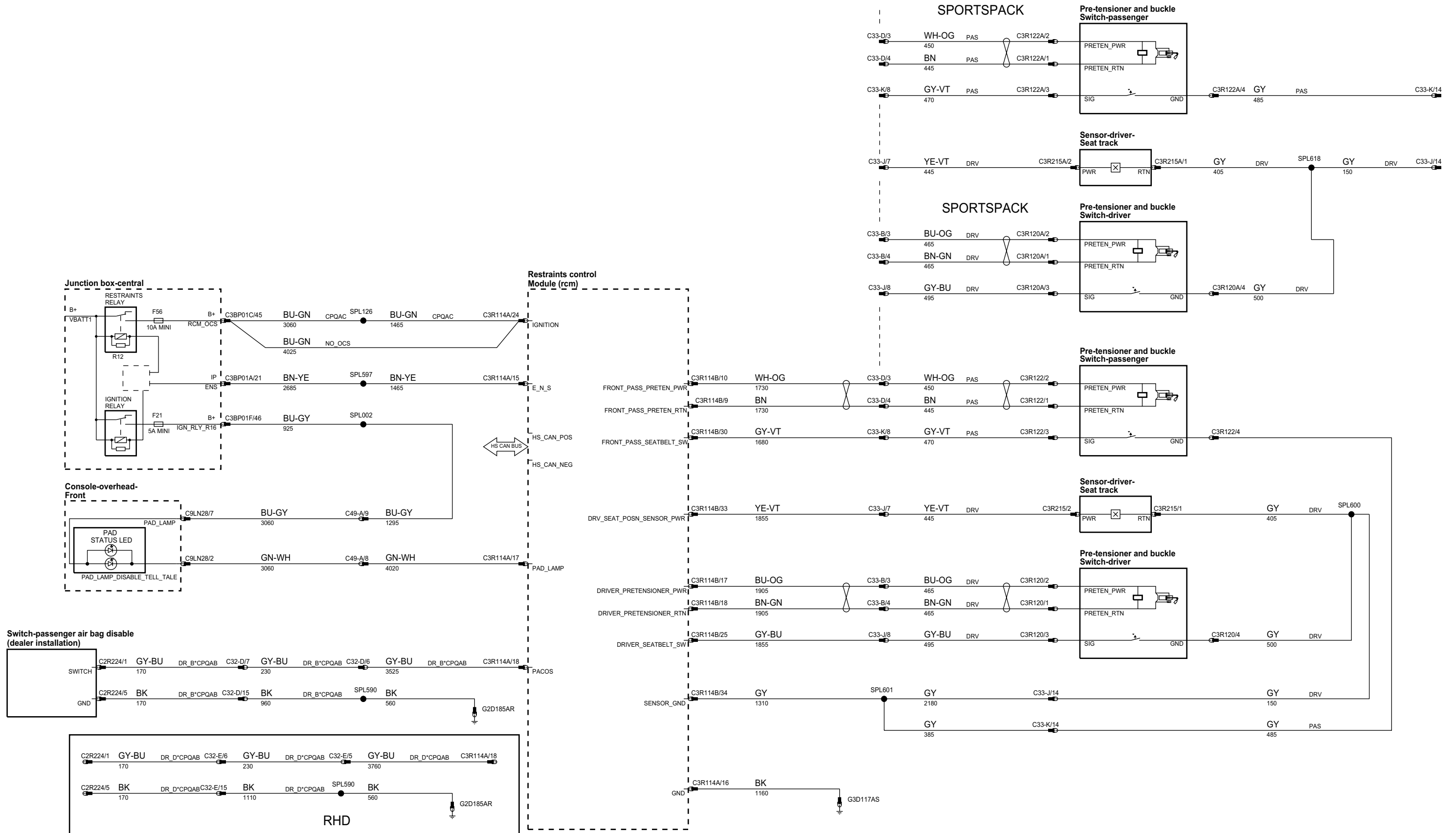

phcw93-70150-e-a3

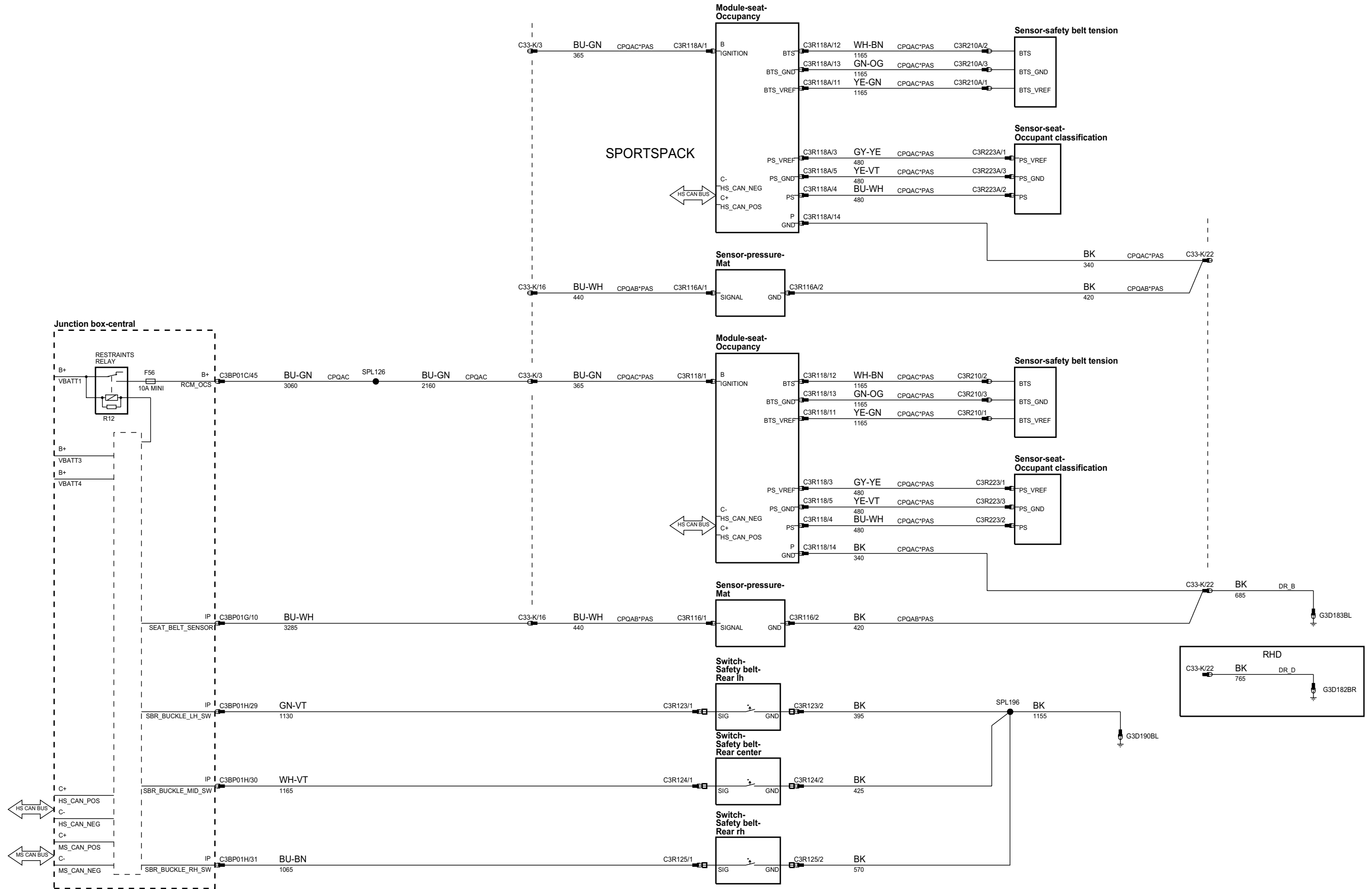

phcw93-70150-d-a3

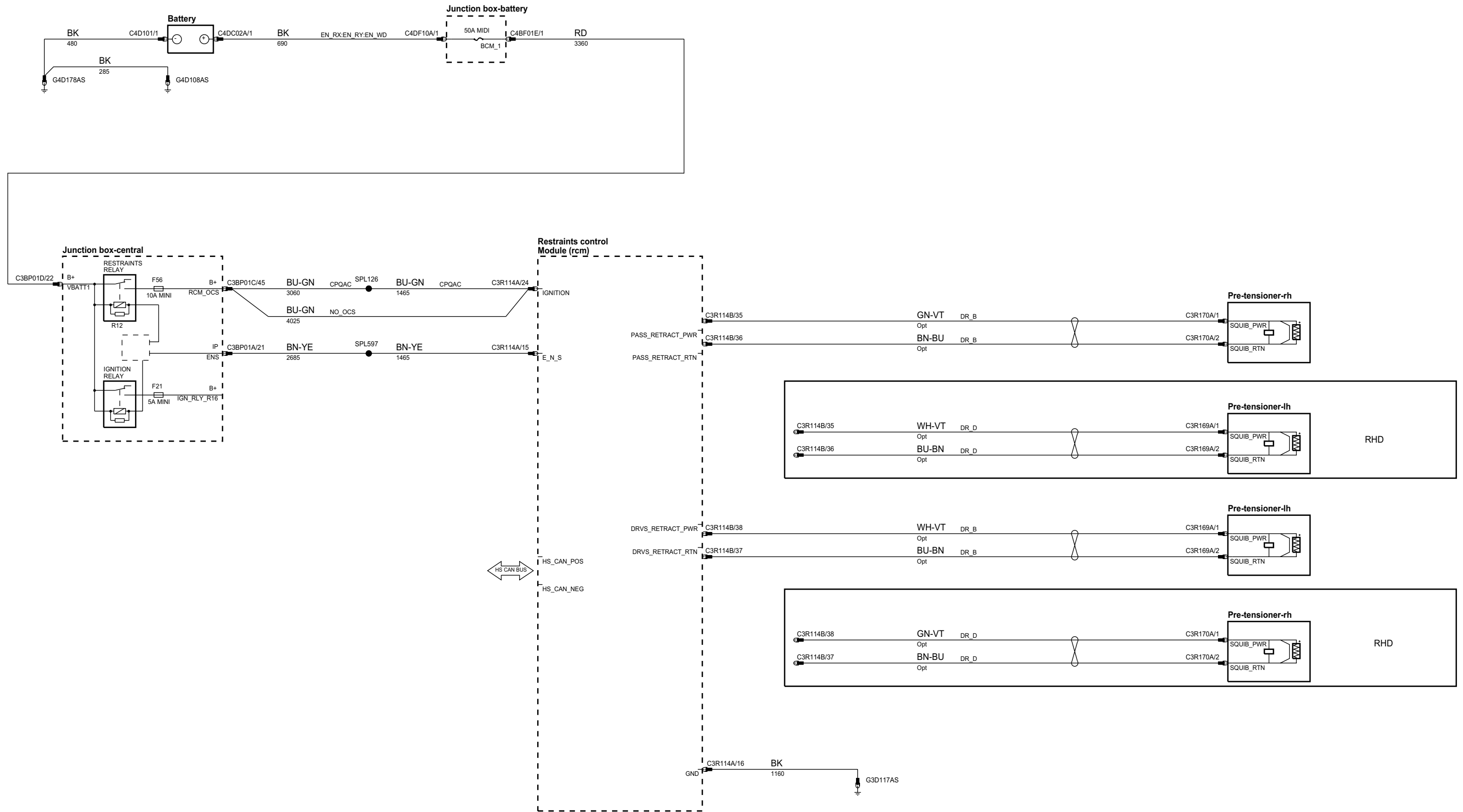

phcw93-70150-a-a3

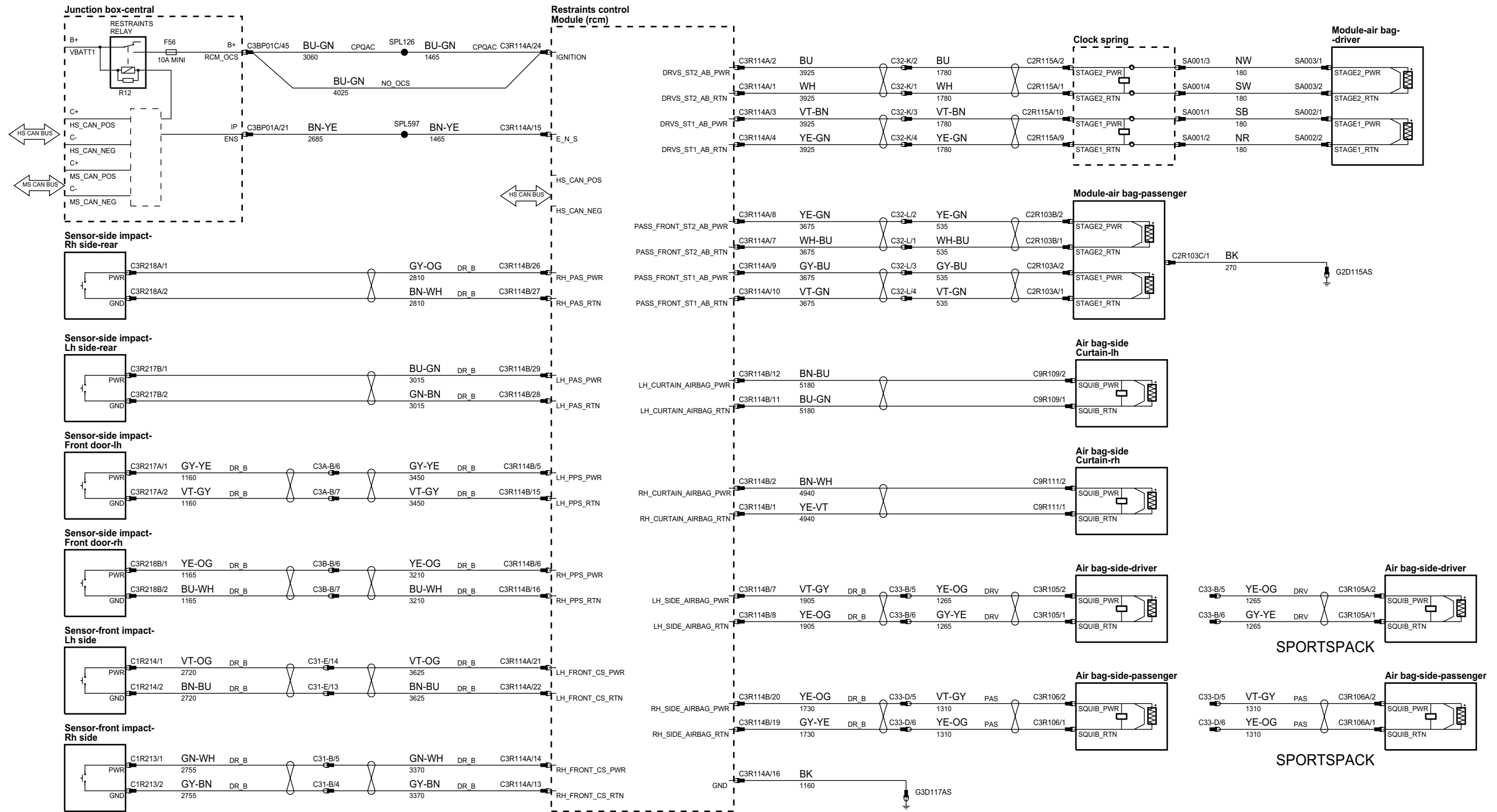

phow93-70150-b-a3

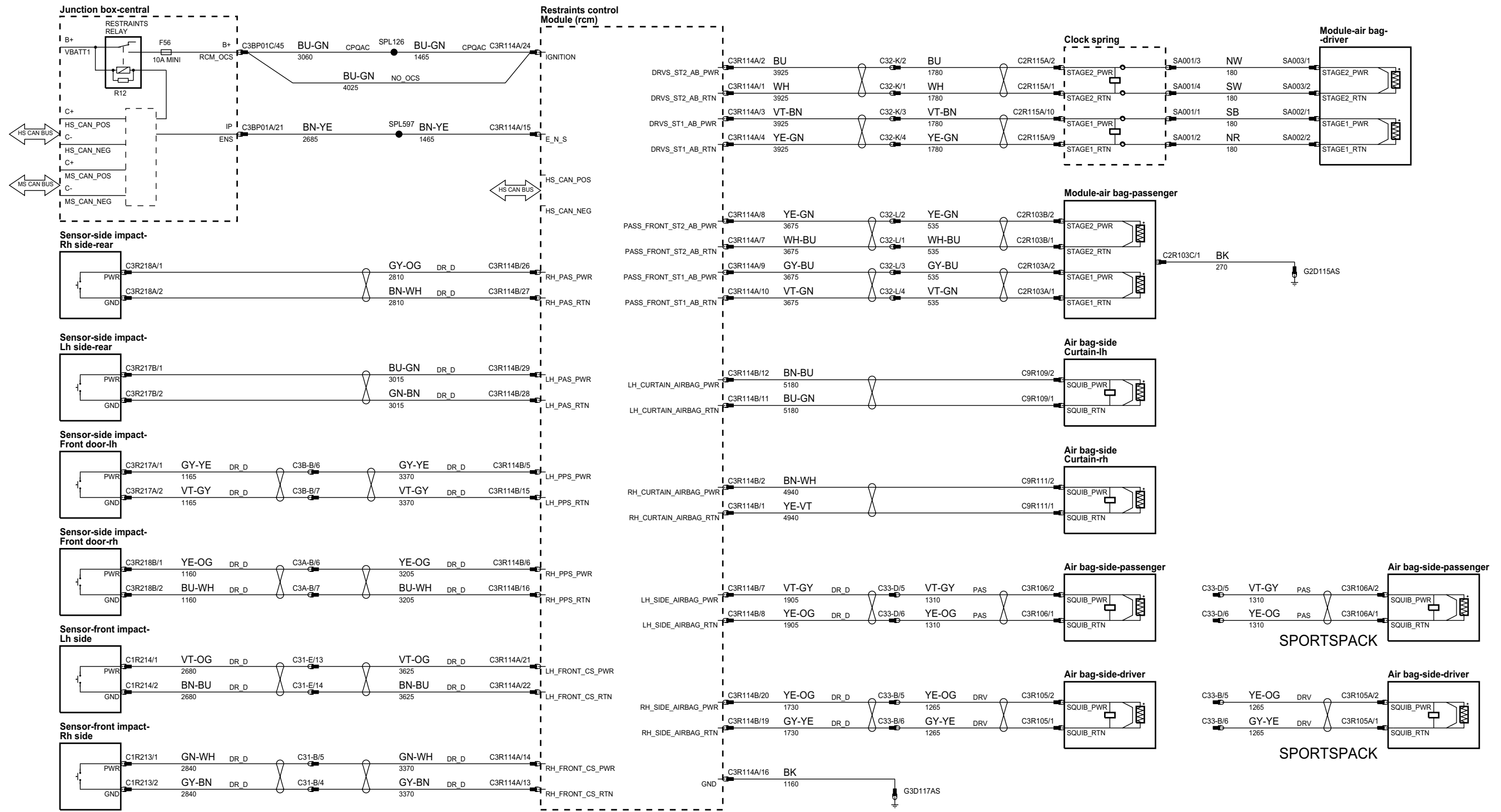

501-20C - PEDESTRIAN PROTECTION SYSTEM

phcw93-70150-g-a3

