

Service Action

Code: 91CD



Subject 3G Cellular Network Sunset

Release Date January 11, 2022

Affected Vehicles

Country	Beginning Model Year	Ending Model Year	Vehicle	Vehicle Count
USA	2017	2017	A4 ALLROAD	2,590
USA	2017	2017	A4 SEDAN	28,697
USA	2017	2017	Q7	50,204
USA	2018	2018	A4 ALLROAD	3,168
USA	2018	2018	A4 SEDAN	25,300
USA	2018	2018	A5 CABRIOLET	6,955
USA	2018	2018	A5 COUPE	6,395
USA	2018	2018	A5 SPORTBACK	15,274
USA	2018	2018	Q5	90,469
USA	2018	2018	Q7	46,755
USA	2018	2018	RS5 COUPE	1,257
USA	2018	2018	S4 SEDAN	5,984
USA	2018	2018	S5 CABRIOLET	2,779
USA	2018	2018	S5 COUPE	3,020
USA	2018	2018	S5 SPORTBACK	7,943
USA	2018	2018	SQ5	14,601
USA	2019	2019	RS5 SPORTBACK	268

Check Campaigns/Actions screen in Elsa on the day of repair to verify that a VIN qualifies for repair under this action. Elsa is the only valid campaign inquiry & verification source.

- ✓ Campaign status must show "open."
- ✓ If Elsa shows other open action(s), inform your customer so that the work can also be completed at the same time the vehicle is in the workshop for this campaign.

About this Service Action

AT&T has announced its plan to discontinue its 3G network in the U.S. starting in February 2022. This will impact the Audi connect services in certain 2017-2019 model year Audi vehicles.

Under this service action Audi is offering customers a software update. Eligible vehicles will also receive a hardware update at no expense to the vehicle owner.

- The software update will deactivate the vehicle's 3G service capability so that error messages do not continually appear once 3G is no longer available.
- The hardware update will be to install a 4G LTE connected car adapter.

The hardware update addresses a majority of the telematics-based services impacted by the sunset of 3G wireless service through a new service, Motion for Audi connect.

The following eligibility matrix provides the information to identify if a vehicle is eligible for the hardware update.

Model Year	Original In-Service Date	Retrofit Kit Eligibility	Software Update (Mandatory for all cars)
2017	All	Yes	Yes

Model Year	Original In-Service Date	Retrofit Kit Eligibility	Software Update (Mandatory for all cars)	
2018 - 2019	On or after		Yes	
	Non-CPO:	February 22, 2018		
	CPO:	February 22, 2017		
	Before			No
	Non-CPO:	February 22, 2018		
	CPO:	February 22, 2017		

- Code Visibility** On or about January 11, 2022, the campaign code will be applied to affected vehicles.
- Owner Notification** Owner notification will take place in January 2022. Owner letter examples are included in this bulletin for your reference.
- Campaign Expiration Date** This service action expires on **January 11, 2027**. Repairs must be performed on or before this date to be eligible for payment. Keep this expiration date in mind when scheduling customers for this action. If a customer wishes to have this service performed after the expiration date, your dealerships normal costs associated with this repair will apply.
- Additional Information** **Please alert everyone in your dealership about this action, including Sales, Service, Parts and Accounting personnel. Contact Warranty if you have any questions.**
Dealers must ensure that every affected inventory vehicle has this service action completed before delivery to consumers.

The information in this document is intended for use only by skilled technicians who have the proper tools, equipment and training to correctly and safely maintain your vehicle. These procedures are not intended to be attempted by "do-it-yourselfers," and you should not assume this document applies to your vehicle, or that your vehicle has the condition described. To determine whether this information applies, contact an authorized Audi dealer. ©2022 Audi Group of America, Inc. and Audi Canada. All Rights Reserved.

Claim Entry Instructions

After campaign has been completed, enter claim as soon as possible to help prevent work from being duplicated elsewhere. Attach the Elsa screen print showing action open on the day of repair to the repair order.

If customer refused campaign work:

- ✓ U.S. dealers: Submit the request through Audi Warranty Online under the Campaigns/Update option.

Service Number	91CD
Damage Code	0099
Parts Vendor Code	002
Claim Type	Sold vehicle: 7 10 Unsold vehicle: 7 90
Causal Indicator	Mark Outside Labor as causal
Vehicle Wash/Loaner	Do not claim wash/loaner under this action

**Vehicles may have more than one criteria. 3G MUST be claimed on all vehicles.
Do NOT claim A1 or A2 or K1 or K2.**

Criteria I.D.	3G		
	OUTSIDE LABOR		
	Labor Op	Amount	Description
	A0001600	\$50.00	Perform software update to deactivate 3G service.
	ADD <u>ONLY</u> IF 4G CONNECTIVITY KIT IS INSTALLED:		
	OUTSIDE MATERIAL		
	Quantity	Outside Part Number	Amount
	1.00	91CDKIT	\$140.27
			Description
			4G Connectivity Kit

SUBMIT A SECOND CLAIM <u>ONLY</u> IF THE 4G CONNECTIVITY KIT WAS INSTALLED			
Service Number	9195		
Damage Code	0010		
Parts Vendor Code	002		
Claim Type	1 SP		
Causal Indicator	Mark Outside Labor as causal		
Vehicle Wash/Loaner	Do not claim wash/loaner under this action		
	OUTSIDE LABOR		
	Labor Op	Amount	Description
	A0001600	\$100.00	Install 4G LTE connected car adapter

Customer Letter Example (USA 2017 MY Vehicles Only)

This notice applies to your vehicle: <MODEL YEAR> <BRAND> <CARLINE>, <VIN>

Subject: Service Action 91CD - 3G Cellular Network Sunset for Certain 2017 Model Year Audi Vehicles

Dear Audi Owner,

As part of Audi's ongoing commitment to customer satisfaction, we are informing you of our decision to conduct a service action on certain 2017 model year Audi vehicles. Our records show that you are the owner of a vehicle affected by this action.

About this Service Action AT&T has announced its plan to discontinue its 3G network in the United States starting in February 2022. This will impact the Audi connect services in certain 2017 model year Audi vehicles.

Under this service action Audi is offering customers of 2017 model year vehicles a software and hardware update.

- The software update will deactivate the vehicle's 3G service capability so that error messages do not continually appear once the 3G network is no longer available.
- The hardware update will be to install a 4G LTE connected car adapter. The hardware update addresses a majority of the telematics-based services impacted by the sunset of 3G wireless service through a new service, Motion for Audi connect.

Work under this service action will take your authorized Audi dealer up to two hours to complete, and will be performed for you free of charge.

What should you do?

In order to limit any possible inconvenience, please contact your authorized Audi dealer as soon as possible to schedule this service. Please keep in mind that your dealer may need additional time for the preparation of the repair, as well as to accommodate their daily workshop schedule. For your convenience, you can also visit www.audiusa.com and click on the "Find a Dealer" link to locate a dealer near you and schedule this service.

This service action will be available **only until January 11, 2027**. If you wish to have this service performed after that date, your dealer's normal costs associated with this repair will apply.

Lease vehicles and address changes

If you are the lessor and registered owner of the vehicle identified in this action, please forward this letter immediately via first-class mail to the lessee within ten (10) days of receipt. If you have changed your address or sold the vehicle, please fill out the enclosed prepaid Owner Reply card and mail it to us so we can update our records.

Can we assist you further?

If your authorized Audi dealer fails or is unable to complete this work free of charge within a reasonable time, please contact Audi Customer Experience at 1-800-253-2834 or via our "Contact Us" page at www.audiusa.com.

Checking your vehicle for open Recalls and Service Campaigns

To check your vehicle's eligibility for repair under this or any other recall/service campaign, please visit the **Recall/Service Campaign Lookup** tool at www.audiusa.com and enter your Vehicle Identification Number (VIN).

We apologize for any inconvenience this matter may cause; however we are taking this action to help ensure your vehicle continues to meet and exceed your expectations.

Sincerely,

Audi Customer Protection

Customer Letter Example (USA 2018-2019 MY Vehicles Only)

This notice applies to your vehicle: <MODEL YEAR> <BRAND> <CARLINE>, <VIN>

Subject: Service Action 91CD - 3G Cellular Network Sunset for Certain 2018-2019 Model Year Audi Vehicles

Dear Audi Owner,

As part of Audi's ongoing commitment to customer satisfaction, we are informing you of our decision to conduct a service action on certain 2018-2019 model year Audi vehicles. Our records show that you are the owner of a vehicle affected by this action.

About this Service Action AT&T has announced its plan to discontinue its 3G network in the United States starting in February 2022. This will impact the Audi connect services in certain 2018-2019 model year Audi vehicles.

Under this service action, Audi is offering customers of 2018-2019 model year vehicles a software update that will deactivate the vehicle's 3G service capability so that error messages do not continually appear once the 3G network is no longer available. This software update is free of charge.

Your authorized Audi dealer will let you know if your vehicle is eligible to also receive a hardware update free of charge. This hardware is a 4G LTE connected car adapter that addresses a majority of the telematics-based services impacted by the sunset of 3G wireless service through a new service called Motion for Audi connect.

What should you do? In order to limit any possible inconvenience, please contact your authorized Audi dealer as soon as possible to schedule this service. Please keep in mind that your dealer may need additional time for the preparation of the repair, as well as to accommodate their daily workshop schedule. For your convenience, you can also visit www.audiusa.com and click on the "Find a Dealer" link to locate a dealer near you and schedule this service.

This service action will be available **only until January 11, 2027**. If you wish to have this service performed after that date, your dealer's normal costs associated with this repair will apply.

Lease vehicles and address changes If you are the lessor and registered owner of the vehicle identified in this action, please forward this letter immediately via first-class mail to the lessee within ten (10) days of receipt. If you have changed your address or sold the vehicle, please fill out the enclosed prepaid Owner Reply card and mail it to us so we can update our records.

Can we assist you further? If your authorized Audi dealer fails or is unable to complete this work free of charge within a reasonable time, please contact Audi Customer Experience at 1-800-253-2834 or via our "Contact Us" page at www.audiusa.com.



Checking your vehicle for open Recalls and Service Campaigns To check your vehicle's eligibility for repair under this or any other recall/service campaign, please visit the **Recall/Service Campaign Lookup** tool at www.audiusa.com and enter your Vehicle Identification Number (VIN).

We apologize for any inconvenience this matter may cause; however we are taking this action to help ensure your vehicle continues to meet and exceed your expectations.

Sincerely,

Audi Customer Protection

Required Tools

 <p style="margin-top: 10px;">Battery Tester/Charger - GRX3000VAS- (or equivalent)</p>	 <p style="margin-top: 10px;">Diagnostic Tester -VAS6150X/VAS6160X- (or equivalent)</p>
---	---

Repair Instruction

Section A - Check for Previous Repair

Applicable criteria ID(s)	Campaign/Action Status
01 ← 2	Open ← 1

EXAMPLE

- Enter the VIN in Elsa and proceed to the "Campaign/Action" screen.

TIP

On the date of repair, print this screen and keep a copy with the repair order.

- Confirm the Campaign/Action is open <arrow 1>. If the status is closed, no further work is required.
- Note the Applicable Criteria ID <arrow 2> for use in determining the correct work to be done and corresponding parts associated.

Campaign/Action	Start	Designation
← 3	2015-11-10	W-SERV_ACT -
	2018-12-13	RECALL -
	2017-05-16	A-RECALL -

EXAMPLE

CRITICAL REPAIR STEP

STOP! STOP!

If multiple software update Campaign/Actions are open, they must be performed in order of the Start date <arrow 3>. The oldest should be performed first.

- All Safety Recalls must be completed prior to completing this campaign.

NOTE

- Damages resulting from improper repair or failure to follow these work instructions are the dealer's responsibility and are not eligible for reimbursement under this action.
- Diagnosis and repair of pre-existing conditions in the vehicle are not covered under this action.

IMPORTANT REPAIR INFORMATION



Read the following information carefully to determine what repair steps are necessary for the vehicle being worked on.

Section B – Control Module Software Update

- ALL vehicles require the software update to de-activate the in-car Audi connect CARE services.
- The software update will deactivate the vehicle's 3G service capability so that error messages do not continually appear once 3G is no longer available.

Section C – Retrofit Kit Installation

- Installation of the retrofit kit is elective.
- Install the retrofit kit under this action **ONLY** if the customer requests it.
- For 2018 and 2019 MY vehicles, eligibility is dependent on the vehicles original in-service date.

Model Year	Original In-Service Date		Retrofit Kit Eligibility	Software Update (Mandatory for all cars)
2018 - 2019	On or after		Yes	Yes
	Non-CPO:	February 22, 2018		
	CPO:	February 22, 2017		
	Before		No	
	Non-CPO:	February 22, 2018		
CPO:	February 22, 2017			

NOTE: If a customer declines the retrofit kit installation at the time the 91CD campaign is performed, they may have the option to purchase the retrofit kit at a later date.

Section B – Control Module Software Update

NOTE

Prior to launching the VAS Diagnostic Tester and starting an update, ensure the following conditions are met;

- ✓ **The ODIS software is completely up to date.**
 - Refer to the “Alerts” section on ServiceNet home page for the current ODIS version.
- ✓ **The battery charger is connected to the vehicle battery and remains connected for the duration of the software update.**
 - Battery voltage must remain above 12.5 volts for the duration of the software update. Failure to do so may cause the update to fail, which could result in damage to the control module. Control modules damaged by insufficient voltage will not be covered.
- ✓ **The screen saver and power saving settings are off.**
 - Failure to do so may result in the tester entering power save mode during the software update, which could result in damage to the control module.
- ✓ **The VAS Diagnostic Tester is plugged in using the supplied power adapters.**
 - Under no circumstances should the tester be used on battery power alone during the software update. Failure to do so may result in the tester powering off during the update, which could result in damage to the control module.
- ✓ **Flash process through “Audi Flashing” not Guided Fault Finding (GFF).**
 - DO NOT USE Guided Fault Finding (GFF) to perform this flash. Using GFF will cause the flash to take longer. Requests for additional time will not be considered.
- ✓ **The VAS Diagnostics Interface MUST ONLY be connected to the tester with a USB cable.**
 - Performing a software update using a Bluetooth or WiFi connection increases the risk of losing connection during the update, which could result in damage to the control module. It also greatly increases the time required to perform the update. Requests for additional time or parts will be denied if the GFF log shows the update was performed using Bluetooth or WiFi.

NOTE

- All campaign software updates must be completed during a single, standalone ODIS Diagnostic Session. You must fully complete this campaign and send all logs before beginning any other campaigns or operations.
- If there are any ODIS “Hot-Fix” patches installed, they must be removed from the scan tool before beginning this operation. ODIS “Hot-Fix” patches may affect the update process.

⚠ WARNING

Radiator Fan(s) may cycle ON high speed during the Update Process! There is a serious risk that personal injury may result if contact is made with spinning fan blades. Keep hands and all objects away from Radiator Fan(s) during Update Process!

i TIP

To Update-Programming using SVM, review and follow instructions in Technical Bulletin 2011732: *Software Version Management (SVM) Operating Instructions*.

The SVM Process must be completed in its entirety so the database receives the update confirmation response. A warranty claim may not be reimbursed if there is no confirmation response to support the claim.

- Open the hood.
- Access the battery charging posts.
- Switch the ignition on.
- Apply the parking brake.
- Switch off all consumers (headlights, heated seats, climate control, etc.).
- Connect the VAS6150X/VAS6160X Diagnostic Tester to the vehicle.
- Start the ODIS program.
- Attach the GRX3000VAS Tester/Charger (or equivalent) IN POWER SUPPLY MODE to the vehicle battery charging posts.

! NOTE

Vehicles with Battery Monitoring Control Module -J367- and/or an EFB Battery:

When connecting the charger to the battery, connect the positive cable to the positive terminal of the battery and connect the negative cable to the grounding lug on the chassis. DO NOT connect the ground cable directly to negative terminal of the battery.

- Turn the hazards on.

⚠ CAUTION

The procedure may cancel itself if the hazard warning lights are not switched on. The hazard warning lights prevent the system from switching to bus sleep mode during the update.

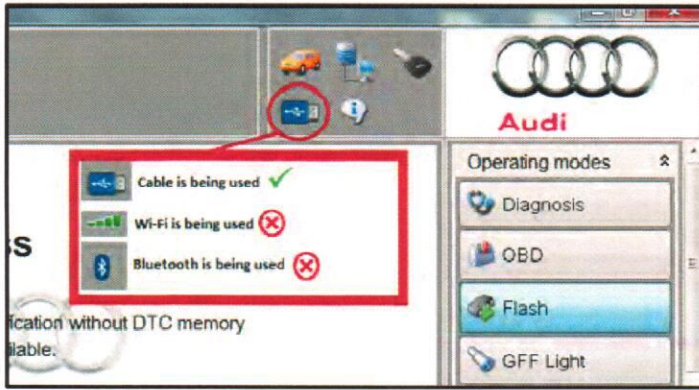

- Confirm that scan tool is communicating with the diagnostic head by USB cable.
 - If the Bluetooth or WiFi symbol is shown, then disconnect the diagnostic head from the vehicle and reconnect the USB cable to the diagnostic head and then reattach to the vehicle.

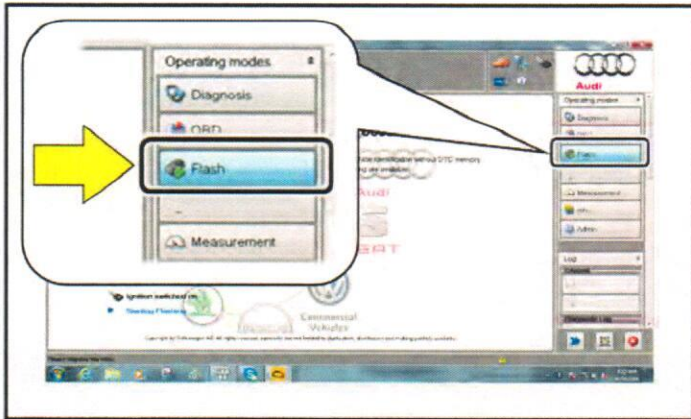

- From the home screen of the scan tool highlight "Flash" <1>.
- Follow the on-screen prompts.

NOTE
 Operating mode "Flash" must be used. Performing this update using "Diagnosis" (Guided Fault Finding) could result in non-payment of the claim.

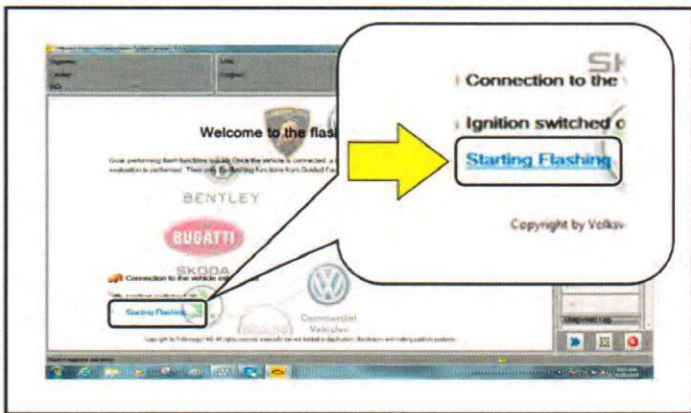

- Select "Starting Flashing" and follow the on-screen prompts.

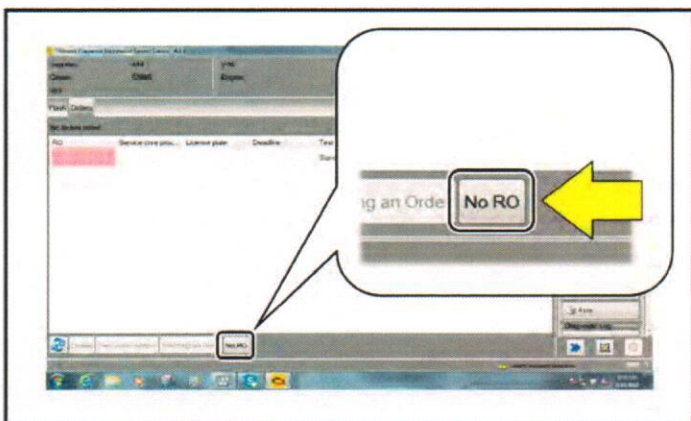

- Select "No RO".

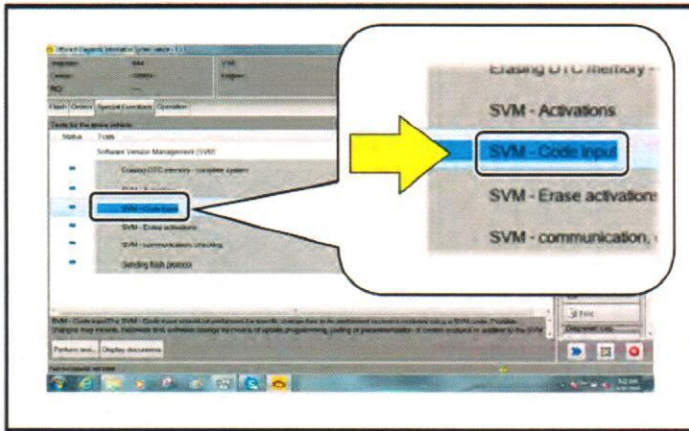

- Highlight “SVM – Code Input”.

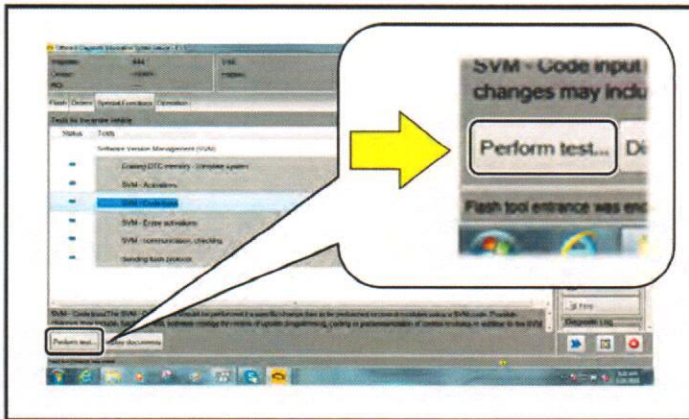

- Select “Perform test”.



NOTE

*Using Bluetooth or WiFi for this action is **PROHIBITED!***

Damage caused to electronic components (e.g. ECM, TCM, etc.) during the SVM update process is not covered.

- Enter the corrective action code (SVM code) as listed below.

SVM code
91CDA108

- Select “Accept”.
- Follow the on-screen prompts.

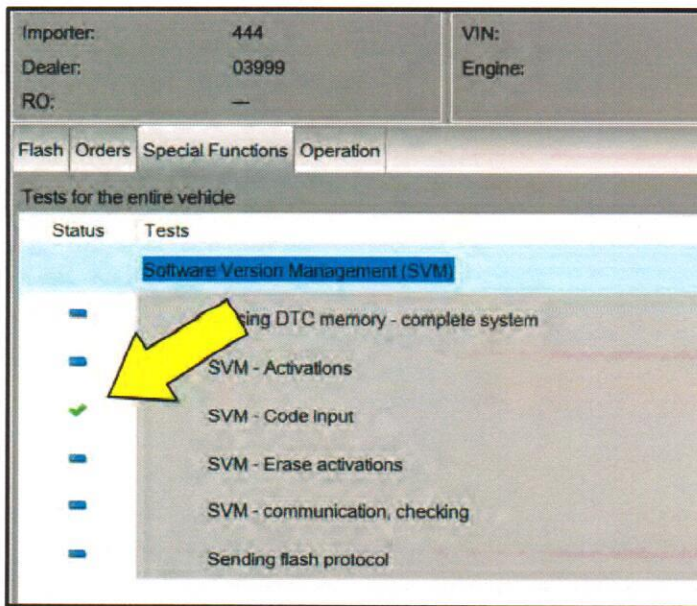

NOTE



This extra ignition cycle step must be followed, otherwise faults stored during the update may not be cleared upon exiting the Flash program.

- After receiving confirmation that the update completed successfully (green check mark) <arrow>, the ignition must be turned off for 60 seconds and then turned back on.

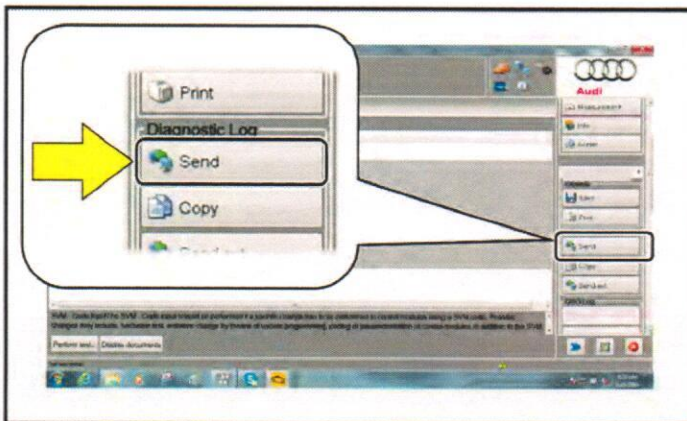

- After receiving confirmation that the flash completed successfully, select “Send” to send the diagnostic protocol online.
- Follow the on-screen prompts.

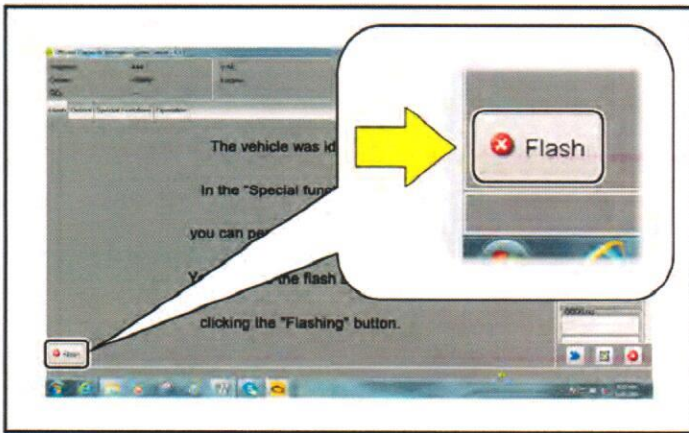

- Click "Flash" to exit the flash session.
- Various event memory entries may be generated after the flashing procedure on some vehicles. Put the vehicle in a corresponding bus sleep mode after performing the update in order to clear the faults.

- Clear all fault codes (if necessary).
- Check that the emergency call feature has been deactivated. (LED in roof module: OFF)

If retrofit kit is NOT being installed:

- Proceed to Section D

If retrofit kit IS being installed:

- Proceed to Section C

Section C – 4G/LTE Retrofit Kit Installation

Parts Information

**Parts Control Type:
Upper Order Limit**

Parts will be managed with a weekly Upper Order Limit. Please see Parts On Command (POC) for your Upper Order Limit quantity.

**Initial Allocation:
YES**

Dealers will be sent an initial allocation prior to customer notification. If no initial allocation was received, please reference the Repair Projection Tool (below) to view your potential VIN population.

**Repair Projection Tool:
(right click to open)**

Criteria	Quantity	Part Number	P.O.C. Part Description	Ordering Method
A1 or A2	1	ZAW-063-239	ADAPTER SE (retrofit kit for A4, A5, Q5 models)	UOL
K1 or K2	1	ZAW-063-239-A	ADAPTER SE (retrofit kit for Q7)	UOL

Connecting the LTE Retrofit Telematics Device to the Audi Q7

Preparations

ELSA (Electronic Service Information System) reference

- Remove the footwell cover ⇒ General body repairs, interior; Rep. gr. 70; Interior trims; Removing and installing the footwell cover
- Remove the dash panel cover on the driver side ⇒ General body repairs, interior; Rep. gr. 70; Interior trims; Removing and installing the dash panel cover on the driver side
- Remove emergency loudspeaker
- Fasten the cable for the emergency loudspeaker at a suitable place on the standard wiring harness using cloth tape and secure to prevent noise from occurring.

Routing and connecting



TIP

Make sure that all routed wires are long enough to reach the installation positions.

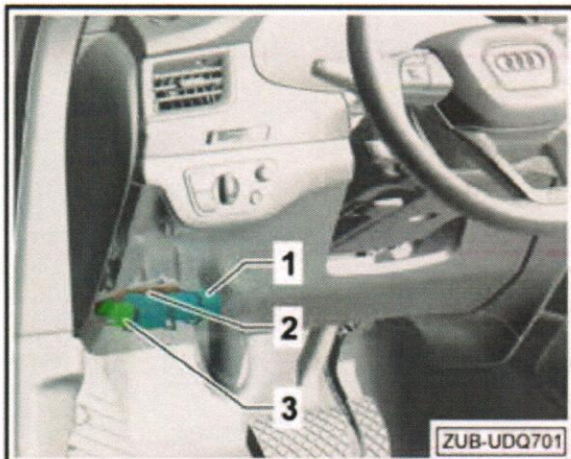

Position in the vehicle

- 1 - LTE Retrofit Telematics Device
- 2 - OBDII extension cable (400 mm, Audi-Cable-001)
- 3 - Connection plug

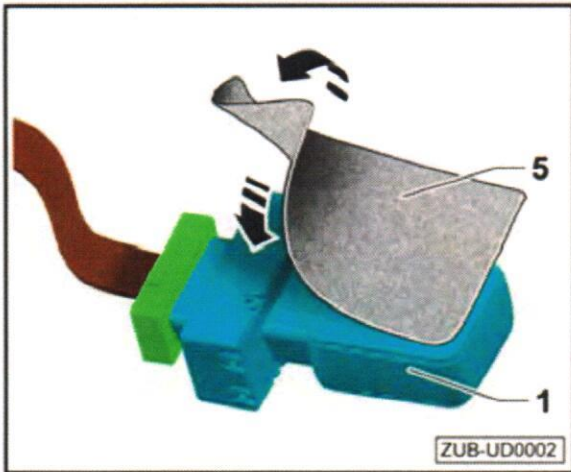

Installing and routing the LTE Retrofit Telematics Device in the vehicle

- Cover the surface of the LTE Retrofit Telematics Device -1- with insulation material -5-.



- For the Q7, the insulation material must be placed on the warning label side. The barcode will be exposed.

ⓘ NOTE

The barcode on the LTE Retrofit Telematics Device must be point upwards because of the position of GNSS antenna.

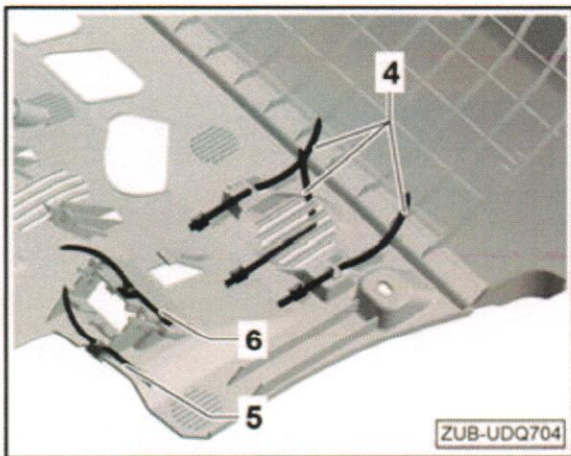

- To secure the LTE Retrofit Telematics Device using the cable ties -4-, use the mounting holes and the grille for the removed emergency loudspeaker.
- Attach a cable tie with adhesive pad -6- to the opening for the OBDII connector
- Attach a cable tie with an edge clip -5- to the edge of the footwell cover

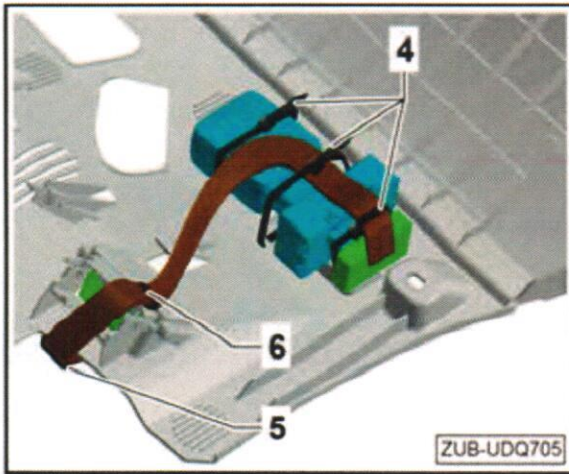

- Position the LTE Retrofit Telematics Device and OBDII extension cable with the insulation material attached in the mounting position on the footwell cover and secure with cable ties -4-.
- Route the OBDII extension cable -2- towards the position of the OBDII slot in the vehicle and secure the cable in a suitable place with a cable tie with an adhesive pad -6- and a cable tie with an edge clip -5- to prevent noise from occurring.
- Install the footwell cover.

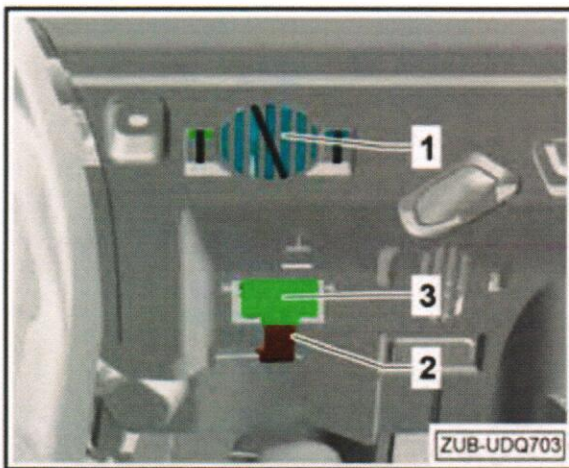

- Connect the OBDII extension cable -2- on the vehicle to the OBDII slot -3-.

Proceed to: Commissioning the LTE Retrofit Telematics Device

Connecting the LTE Retrofit Telematics Device to the Audi A4/A5

Preparations

ELSA (Electronic Service Information System) reference

- Remove the footwell cover ⇒ General body repairs, interior; Rep. gr. 70; Interior trims; Removing and installing the footwell cover
- Remove the storage compartment ⇒ General body repairs, interior; Rep. gr. 70; Interior trims; Removing and installing the storage compartment
- Remove the dash panel cover on the driver side ⇒ General body repairs, interior; Rep. gr. 70; Interior trims; Removing and installing the dash panel cover on the driver side
- Remove emergency loudspeaker
- Fasten the cable for the emergency loudspeaker at a suitable place on the standard wiring harness using cloth tape and secure to prevent noise from occurring.

Applies only to the A5/S5 Cabriolet:

- Release the holder for the knee airbag and set aside the entire component. "Do not" disconnect the connector from the airbag.

Routing and connecting

TIP

Make sure that all routed wires are long enough to reach the installation positions.

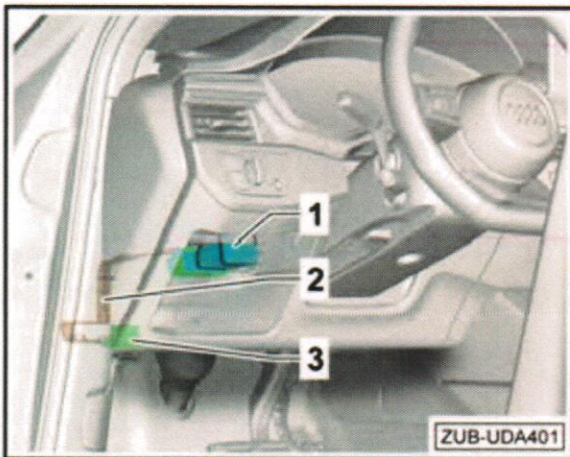

Position in the vehicle

- 1 - LTE Retrofit Telematics Device
- 2 - OBDII extension cable (550 mm, Audi-Cable-002)
- 3 - Connection plug

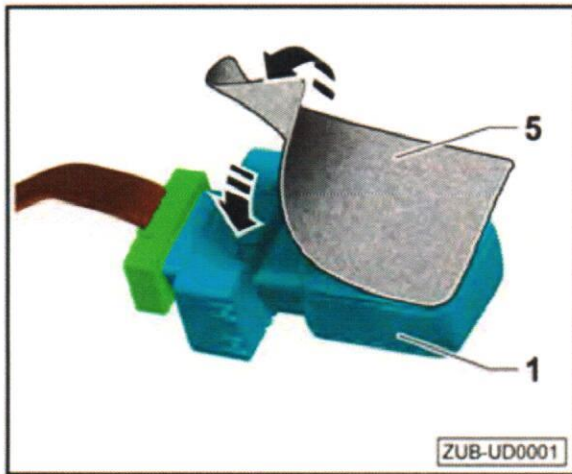

Installing and routing the LTE Retrofit Telematics Device in the vehicle

- The insulation material must cover the barcode on the LTE Retrofit Telematics Device.
- Cover the surface on one side of the LTE Retrofit Telematics Device -1- with insulation material -5-.



- For the A4 and A5 variants, the insulation material must be placed on the bar code side. The warning label will be exposed.

NOTE

The warning label on the LTE Retrofit Telematics Device must be point upwards because of the position of GNSS antenna.

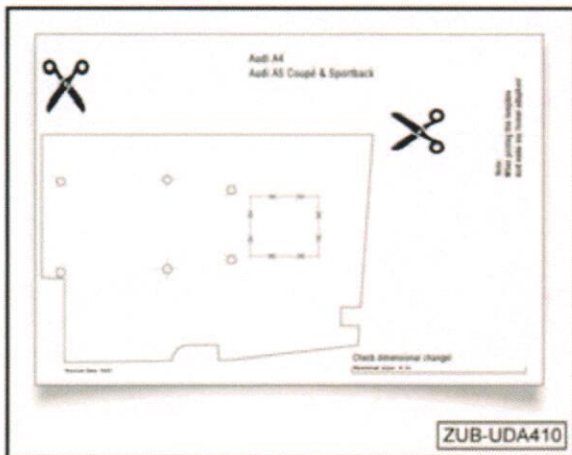

Applies to the A4, A4 Avant; A5 Coupe, A5 Sportback

- The appendix of the fitting instructions contains a template for positioning the LTE Retrofit Telematics Device in the storage compartment.
- Print out the template.
- The template features a positioning mark. Using a ruler, measure the positioning mark. It must measure "4 in."
- If the dimension is too small or large, the printer options in "Page Sizing and Handling" must be changed to "Actual size".

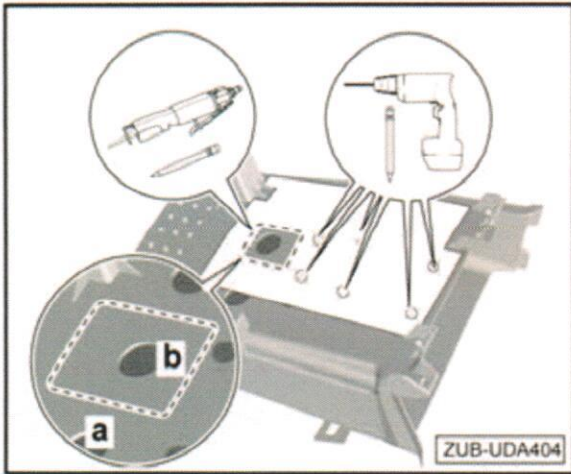

- Cut out the template.
- Position the template for the LTE Retrofit Telematics Device on the storage compartment in the installation position and mark the holes for the cable ties and cable ducts.
- Drill M5 holes for the cable ties.
- Using suitable workshop equipment, drill and deburr the opening -a-b- for the OBDII extension cable.

TIP

Drilling pilot holes at the corners of the -a-b- cutout will make cutting easier.

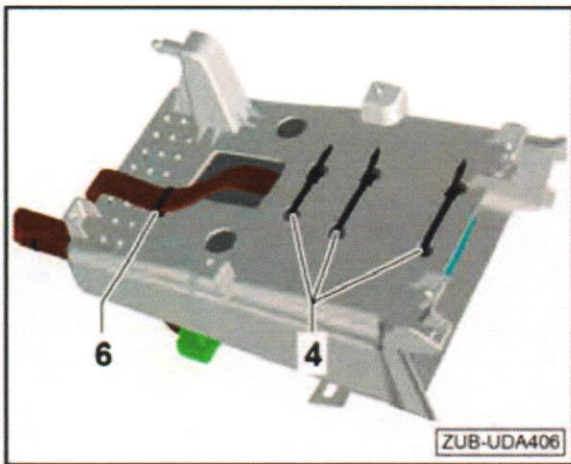

- Position the LTE Retrofit Telematics Device with the insulation material attached in the storage compartment in the installation position and secure with cable ties -4-.
- Route the OBDII extension cable towards the position of the OBDII slot in the vehicle and secure it in a suitable place using a cable tie with adhesive pad -6- to prevent noise from occurring.

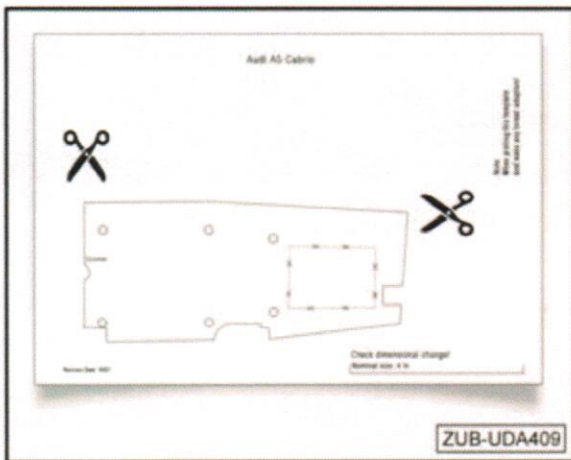

Applies to the A5/S5 Cabriolet

- The appendix of the fitting instructions contains a template for positioning the LTE Retrofit Telematics Device in the storage compartment.
- Print out the template.
- The template features a positioning mark. Using a ruler, measure the positioning mark. It must measure "4 in."
- If the dimension is too small or large, the printer options in "Page Sizing and Handling" must be changed to "Actual size".

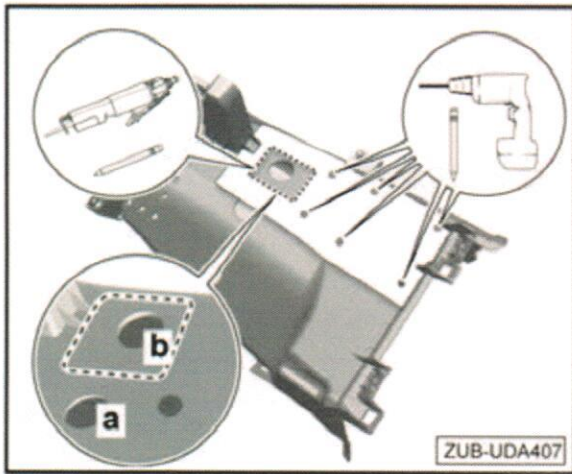

- Cut out the template.
- Position the template for the LTE Retrofit Telematics Device on the storage compartment in the installation position and mark the holes for the cable ties and cable ducts.
- Drill M5 holes for the cable ties.
- Using suitable workshop equipment, drill and deburr the opening -a-b- for the OBDII extension cable.

TIP

Drilling pilot holes at the corners of the -a-b- cutout will make cutting easier.

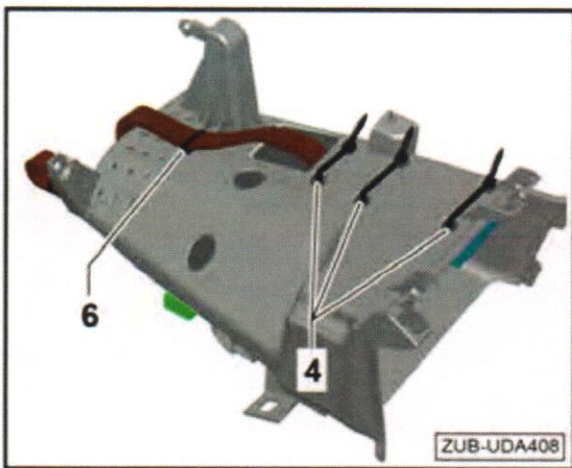

- Position the LTE Retrofit Telematics Device with the insulation material attached in the storage compartment in the installation position and secure with cable ties -4-.
- Route the OBDII extension cable towards the position of the OBDII slot in the vehicle and secure it in a suitable place using a cable tie with adhesive pad -6- to prevent noise from occurring.

Applies to all models:

- Install the storage compartment with footwell cover.

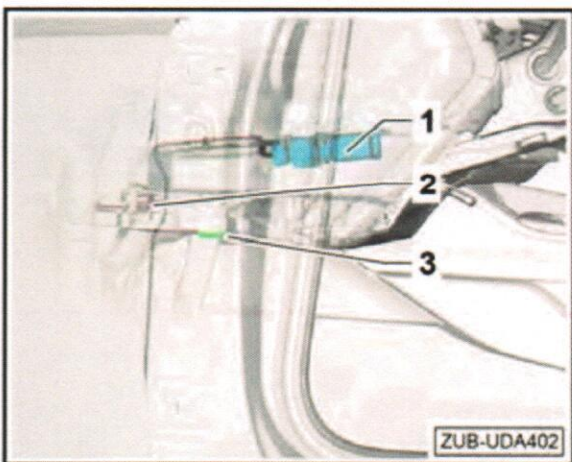

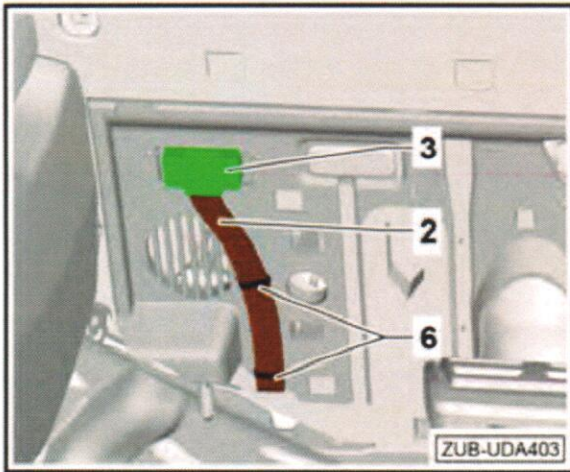

- Connect the OBDII extension cable -2- on the vehicle to the OBDII slot -3-.
- Secure the OBDII extension cable -2- in a suitable place using cable ties with adhesive pad -6- to prevent noise from occurring.

Proceed to: Commissioning the LTE Retrofit Telematics Device

Connecting the LTE Retrofit Telematics Device to the Audi Q5

Preparations

ELSA (Electronic Service Information System) reference

- Remove the footwell cover ⇒ General body repairs, interior; Rep. gr. 70; Interior trims; Removing and installing the footwell cover
- Remove the storage compartment ⇒ General body repairs, interior; Rep. gr. 70; Interior trims; Removing and installing the storage compartment
- Remove the dash panel cover on the driver side ⇒ General body repairs, interior; Rep. gr. 70; Interior trims; Removing and installing the dash panel cover on the driver side
- Remove emergency loudspeaker
- Fasten the cable for the emergency loudspeaker at a suitable place on the standard wiring harness using cloth tape and secure to prevent noise from occurring.

Routing and connecting

TIP

Make sure that all routed wires are long enough to reach the installation positions.

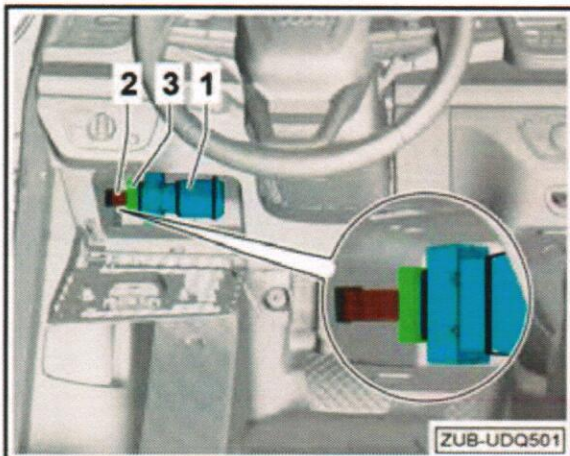

Position in the vehicle

- 1 - LTE Retrofit Telematics Device
- 2 - OBDII extension cable (550 mm, Audi-Cable-002)
- 3 - Connection plug

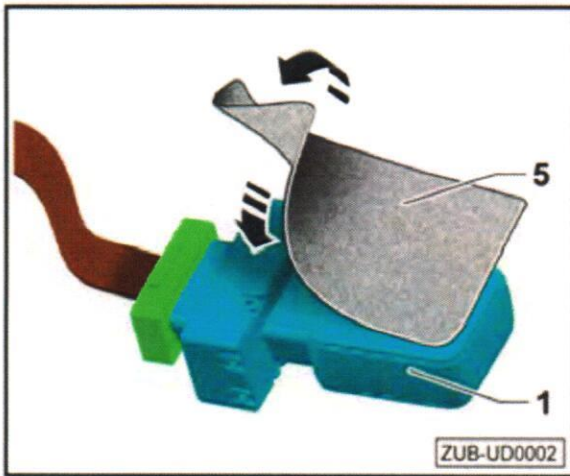

Installing and routing the LTE Retrofit Telematics Device in the vehicle

- Cover the surface of the LTE Retrofit Telematics Device -1- with cut-to-size insulation material -5-.



- For the Q5, the insulation material must be placed on the warning label side. The barcode will be exposed.

! NOTE

The barcode on the LTE Retrofit Telematics Device must be point upwards because of the position of GNSS antenna.

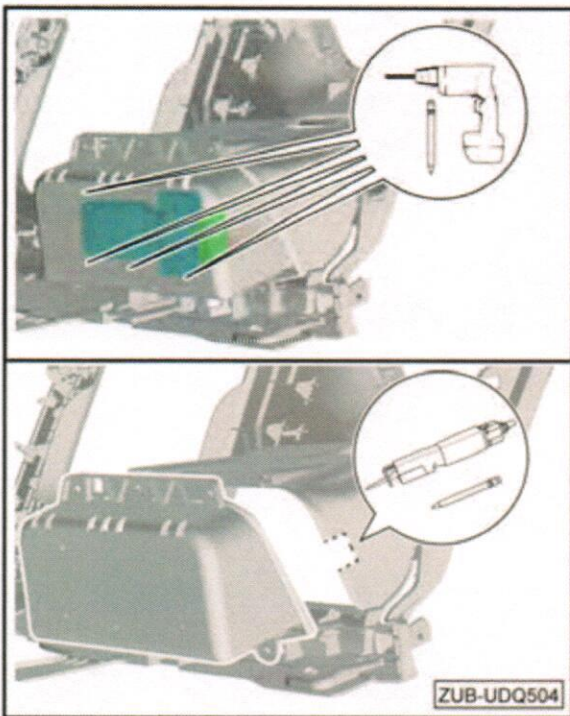

- Position the LTE Retrofit Telematics Device -1- on the cover of the storage compartment in the installation position and mark the holes for the cable ties.
- Drill M5 holes for the cable ties.
- Drill an opening measuring -18 mm x 18 mm- on the dash panel cover in the area of the cable feed-through using suitable workshop equipment and deburr the opening.

i TIP

Drilling pilot holes at the corners of the cutout will make cutting easier.

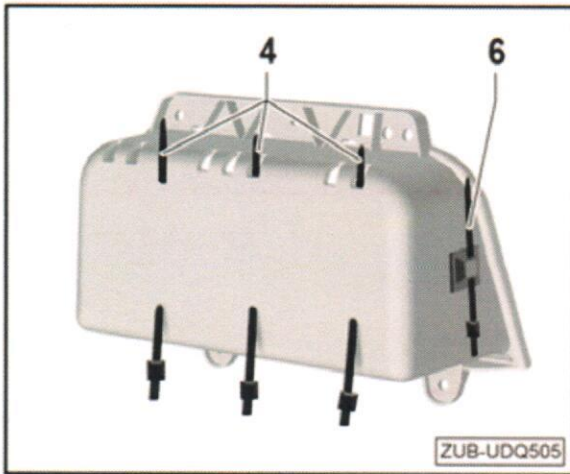

- Position the LTE Retrofit Telematics Device - 1- with the insulation material attached on the storage compartment in the installation position and secure with cable ties -4-.
- Attach a cable tie with adhesive pad -6- to the side.

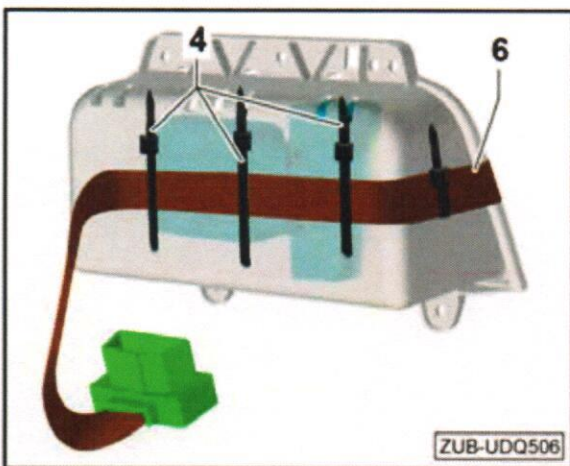

- Route the OBDII extension cable towards the position of the OBDII slot in the vehicle and secure it in a suitable place using a cable tie with adhesive pad -6- to prevent noise from occurring.
- Leave the end of the OBDII extension cable loose.

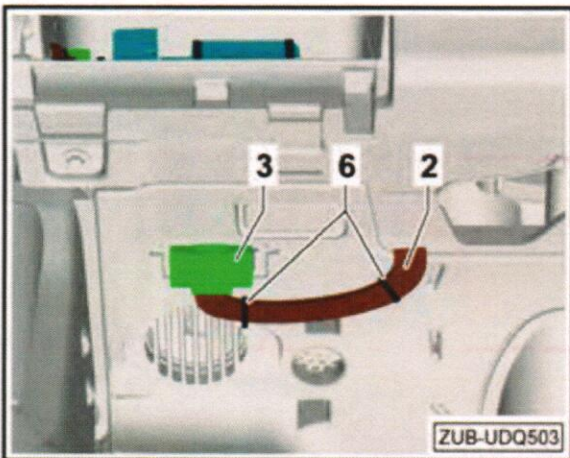

- Connect the OBDII extension cable -2- on the vehicle to the OBDII slot -3-.
- Secure the OBDII extension cable -2- in a suitable place using cable ties with adhesive pad -6- to prevent noise from occurring.

Proceed to: Commissioning the LTE Retrofit Telematics Device

Commissioning the LTE Retrofit Telematics Device

- To successfully use Motion for Audi Connect app, an active and paired Bluetooth connection between the app and the Audi MMI is necessary to enable SOS emergency calls and roadside assistance calls.
- The connection is visible in the Connection Manager on the MMI. The hardware appears as “AUDI SOS - NO 911 [DO NOT DELETE]”
- The LTE Retrofit Telematics Device can be connected as a secondary device.

Connecting the LTE Retrofit Telematics Device via Bluetooth as a Secondary Device (preferred method if customer’s phone is already paired)

Pre-requisite

- The vehicle is stationary and the ignition is switched on.
- LTE Retrofit Telematics Device connected to OBD2 and ready for operation.



- Select “Telephone”

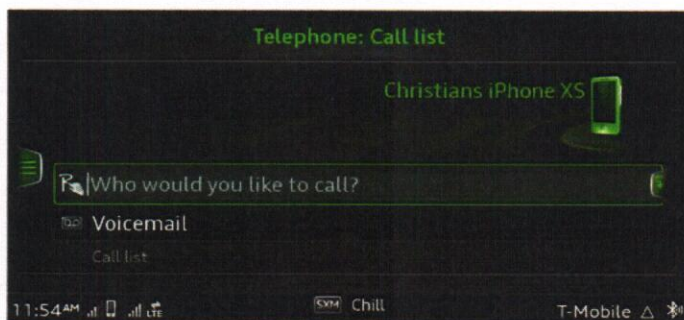

- Example: Customer phone shown as connected device.

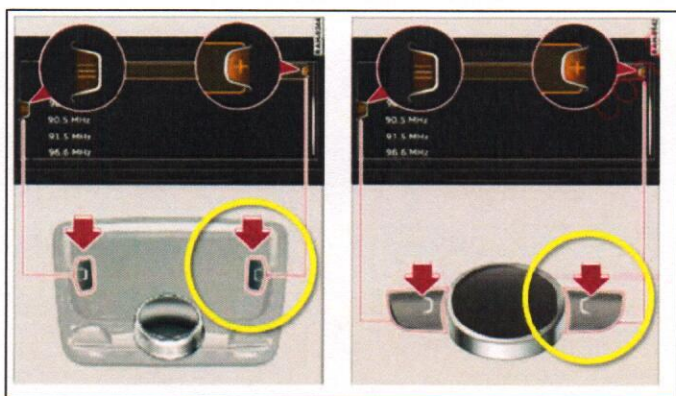

- Press right control button on the MMI control pad to bring up Options menu.

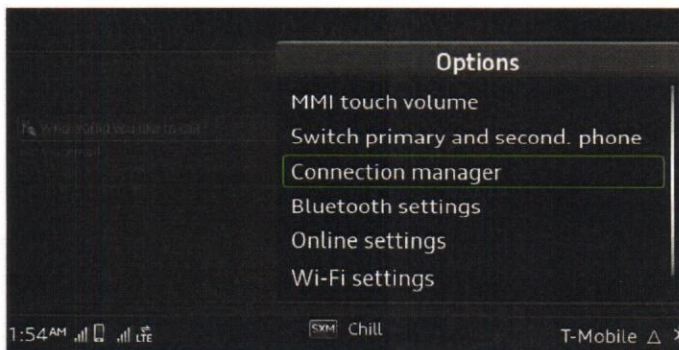

- Select "Connection manager"



- Select "Secondary phone"

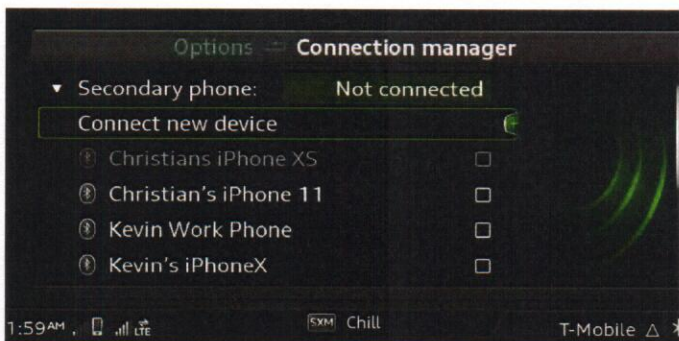

- Select "Connect new device"



- Select "Find new devices"

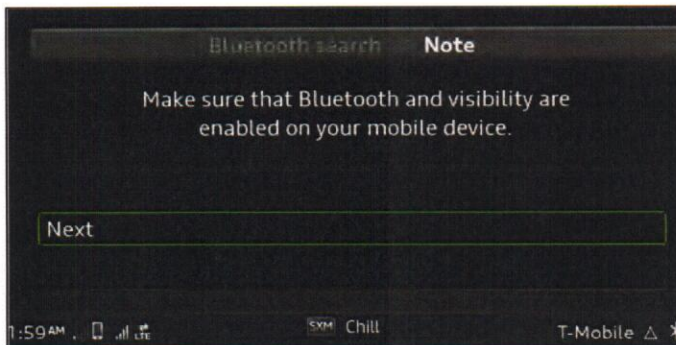

- Select "Next"

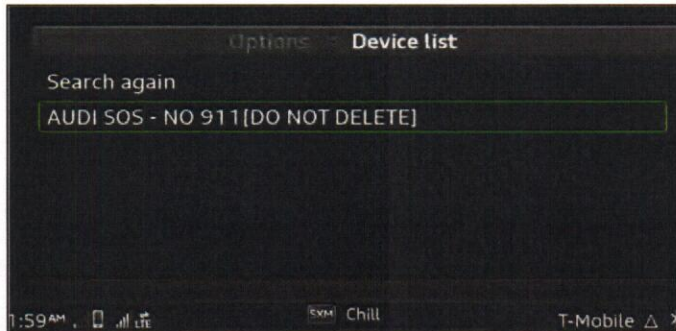

- Select "AUDI SOS – NO 911 [DO NOT DELETE]" from the device list.

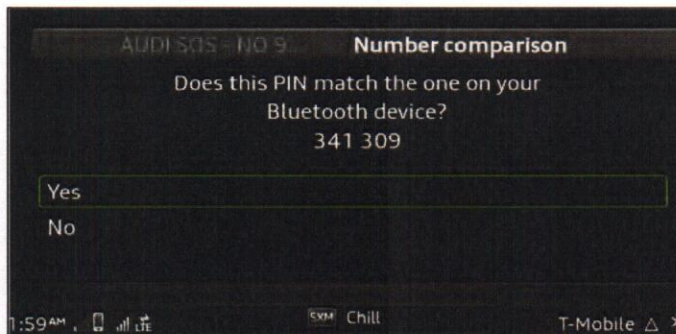

- Confirm the PIN by selecting "Yes"



- The Bluetooth connection will be established.

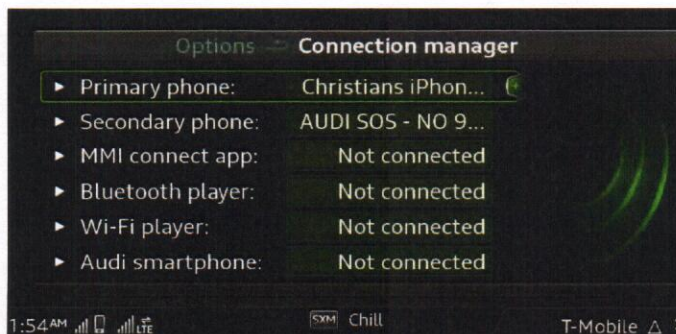

- LTE Retrofit device is now a secondary connected device.

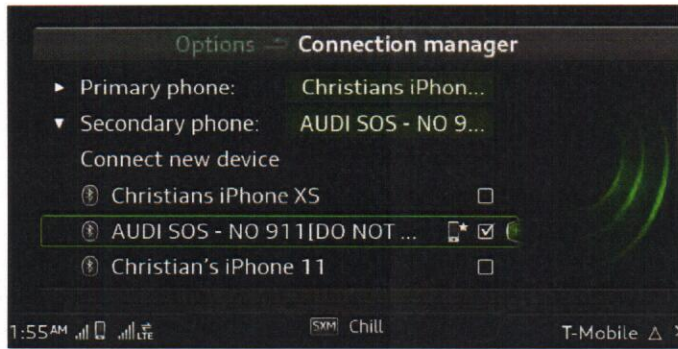

- Ensure “AUDI SOS – NO 911 [DO NOT DELETE]” is selected as the default device.

Proceed to Section D

Connecting the LTE Retrofit Telematics Device via Bluetooth as a Primary Device

Pre-requisite

- The vehicle is stationary and the ignition is switched on.
- LTE Retrofit Telematics Device connected to OBD2 and ready for operation.
- The MMI is not connected to any mobile phone.



- Select "Telephone"

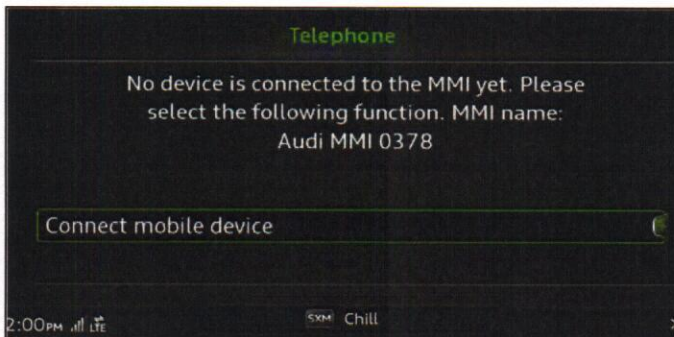

- Select "Connect mobile device"



- Select "Find new devices"

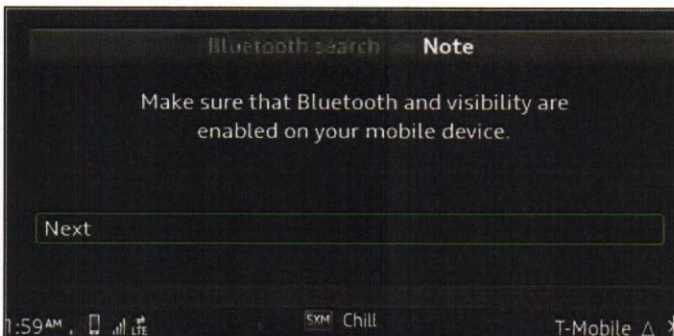

- Select "Next"

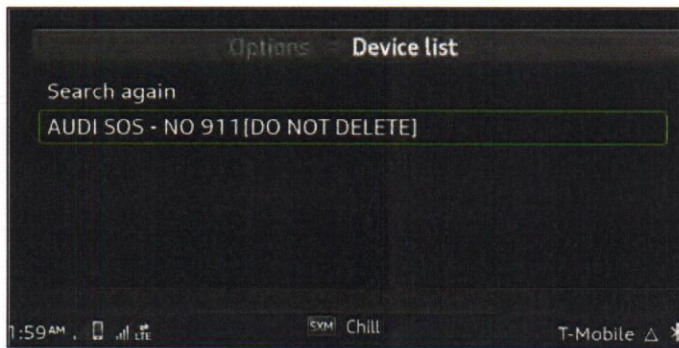

- Select “AUDI SOS – NO 911 [DO NOT DELETE]” from the device list.

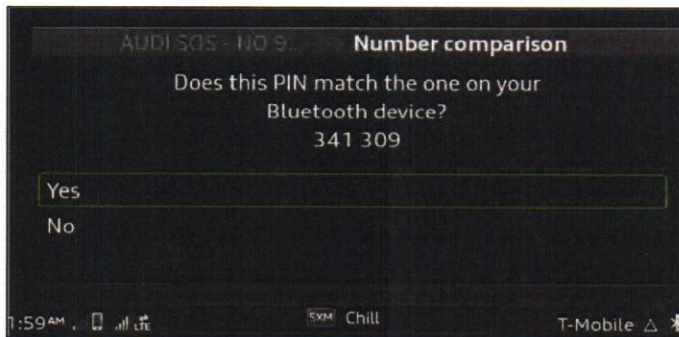

- Confirm the PIN by selecting “Yes”
- *NOTE: there is no need to confirm PIN on telematics device*



- The Bluetooth connection will be established.

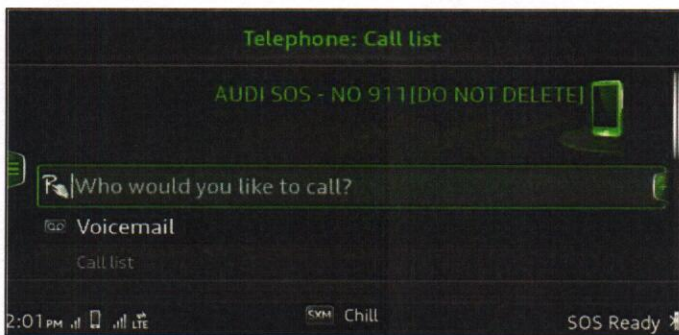

- “AUDI SOS – NO 911 [DO NOT DELETE]” shown as connected device.

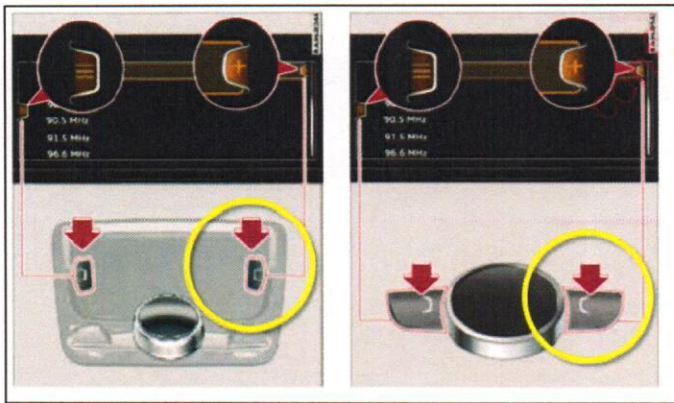

- Press right control button on the MMI control pad to bring up Options menu.

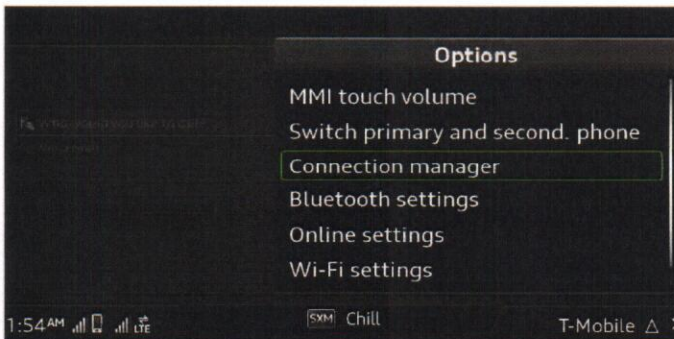

- Select "Connection manager"



- Select "Primary phone"

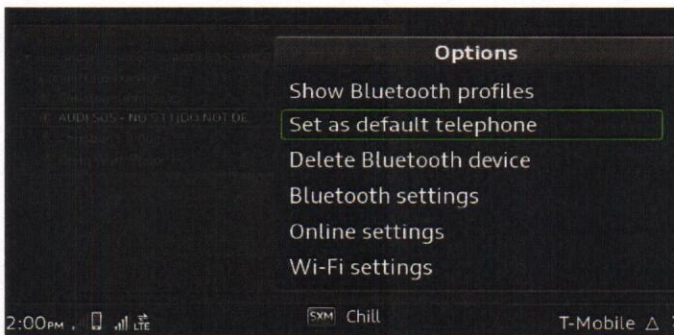

- Select "Set as default telephone"



- LTE Retrofit device is now the primary connected device.

Proceed to Section D

Section D – Campaign Stamp

I certify that this campaign
has been performed in strict
accordance with the applicable
Audi repair procedure.

SAGA Code: _____

Technician: _____

Date: _____

Item#: AUD4927ENG

OR

Je certifie que cette
campagne de rappel a été
exécutée suivant les strictes
directives de réparation
d'Audi

Code de SAGA: _____

Technicien: _____

Date: _____

Item # AUD4927FRE

- Once the campaign has been completed, the technician should stamp the repair order.
- Stamps are available for ordering through the Compliance Label Ordering Portal (item# AUD4927ENG or AUD4927FRE).

Audi A4
Audi A5 Coupé & Sportback

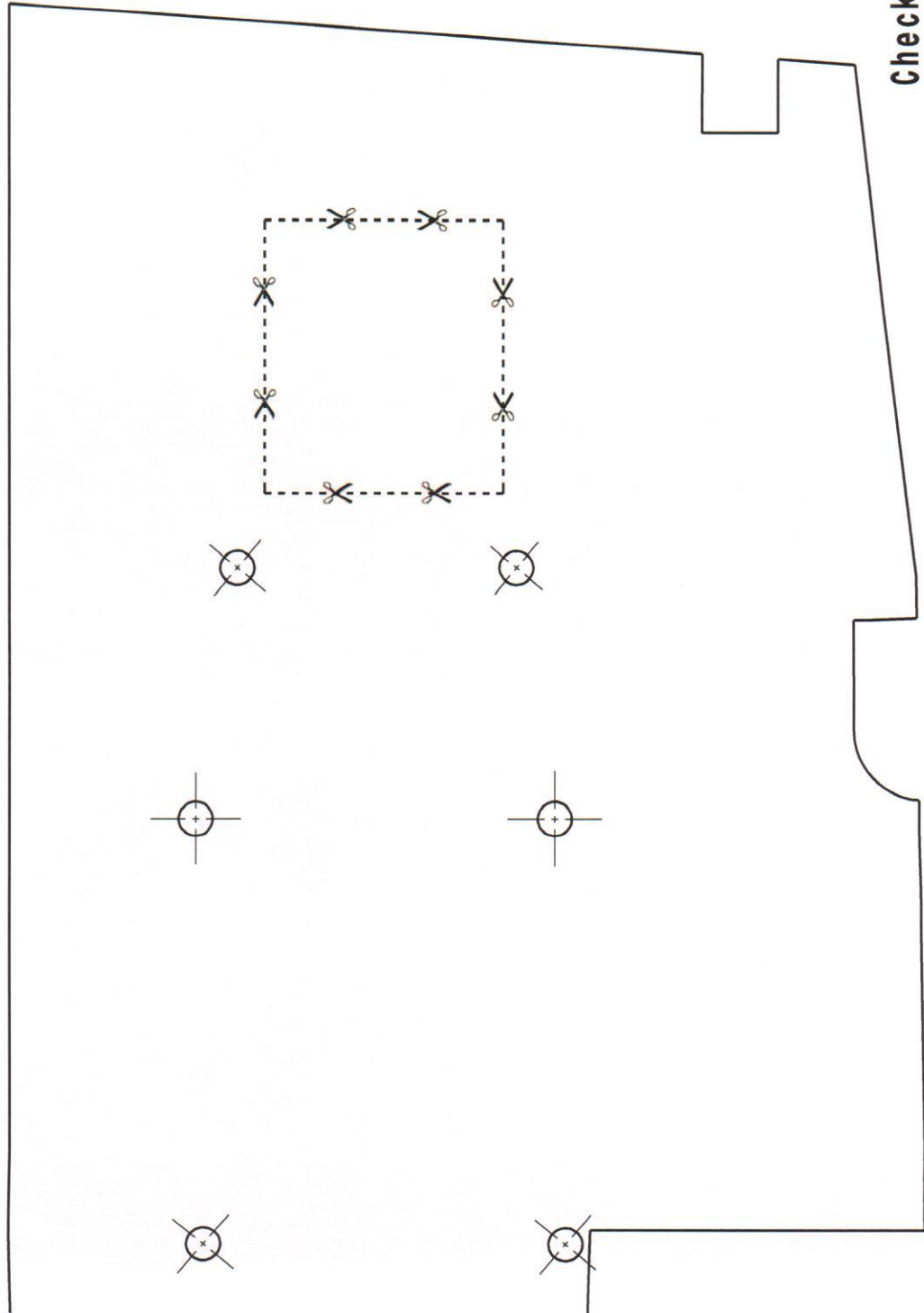

Note:

Check dimensional change!

Nominal size: 4 In

Audi A5 Cabrio

Note:

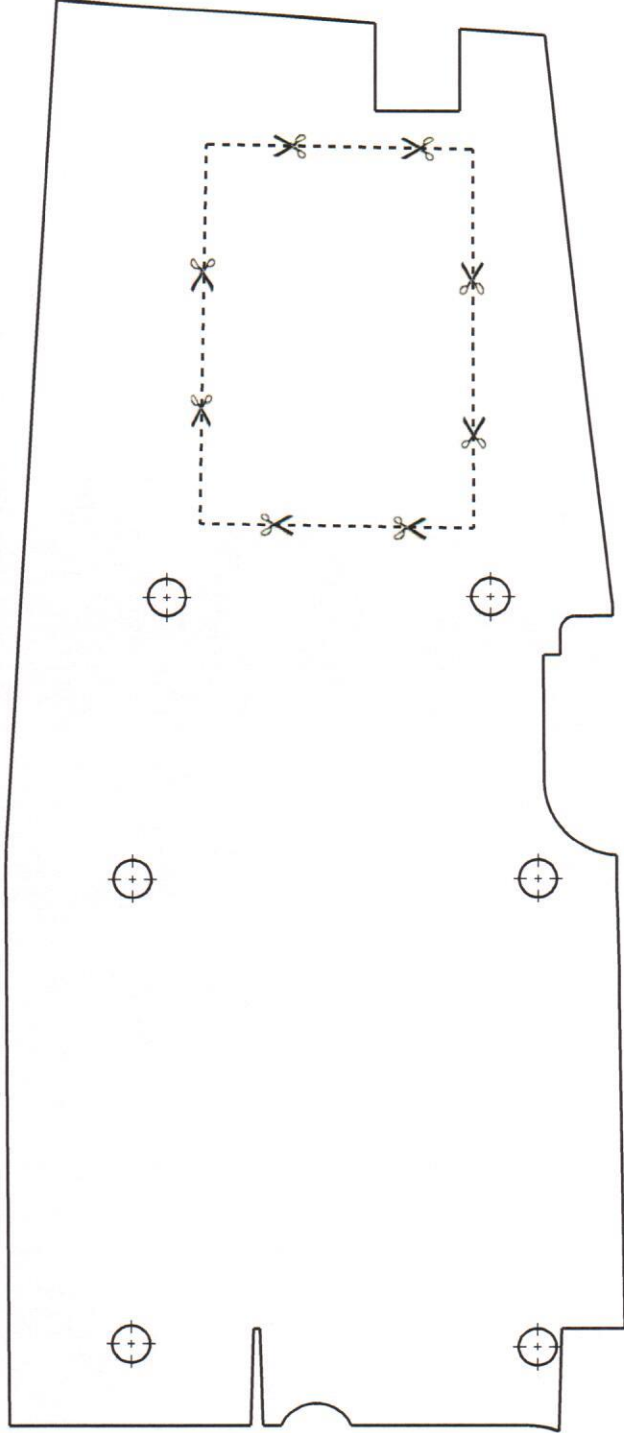

Check dimensional change!

Nominal size: 4 In

Revision Date: 10/21