

**PUBLISHED: 28-FEB-2019**  
**2011.75 XJ RANGE (X351), 303-01C**

**ENGINE - V8 N/A 5.0L PETROL**

**TIMING CHAIN TENSIONER - ENGINE SET** [G1841712]

## REMOVAL AND INSTALLATION

### SPECIAL TOOL(S)



E115265

**303-1447**

Timing Tool

### PART(S)

STEP	PART NAME	QUANTITY
Removal Step 28	Fuel rail supply pipe(s)	1
Installation Step 2	Lower timing cover	1
Installation Step 21	Fuel rail supply pipe(s)	1

## REMOVAL



### WARNING:

This procedure involves fuel handling. Be prepared for fuel spillage at all times and always observe fuel handling precautions. Failure to follow these instructions may result in personal injury.



### CAUTIONS:

- Check all timing components for wear and install new components if required.
- Before disconnecting any components, make sure the area is clean and free from foreign material. When disconnected all openings must be sealed.

**NOTE:**

Some variation in the illustrations may occur, but the essential information is always correct.

1. Refer to: [Petrol and Petrol-Ethanol Fuel Systems Health and Safety Precautions](#) (100-00 General Information, Description and Operation).

2. Refer to: [Fuel System Pressure Release - V6 N/A 3.0L Petrol/V8 N/A 5.0L Petrol/V8 S/C 5.0L Petrol](#) (310-00 Fuel System - General Information, General Procedures).

3. Disconnect the battery ground cable.  
Refer to: [Startup Battery Disconnect and Connect](#) (414-01 Battery, Mounting and Cables, General Procedures).

4. **WARNING:**

Make sure to support the vehicle with axle stands.

Raise and support the vehicle.

5. Refer to: [Cooling System Partial Draining and Vacuum Filling](#) (303-03A Engine Cooling - V8 N/A 5.0L Petrol /V8 S/C 5.0L Petrol, General Procedures).

6. Refer to: [Air Cleaner Outlet Pipe T-Connector - V8 N/A 5.0L Petrol](#) (303-12B Intake Air Distribution and Filtering - V8 N/A 5.0L Petrol/V8 S/C 5.0L Petrol, Removal and Installation).

7.

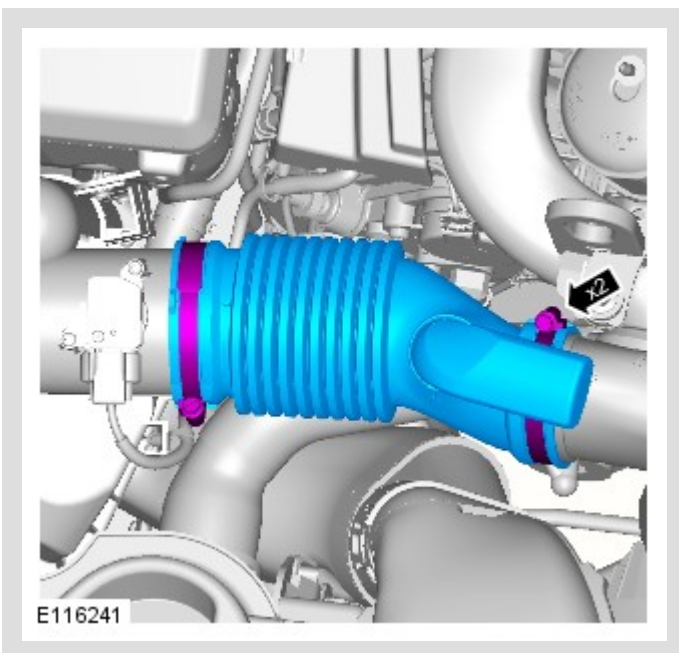

8.

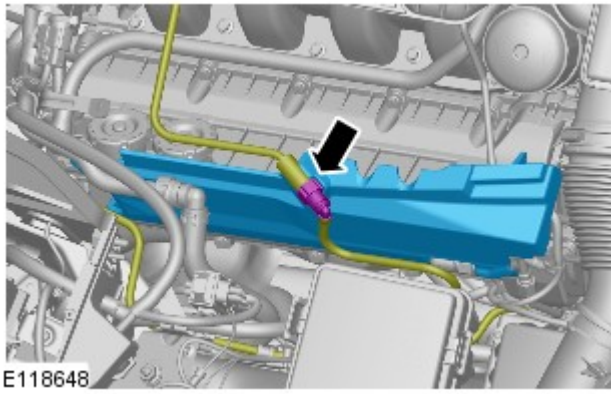

9.

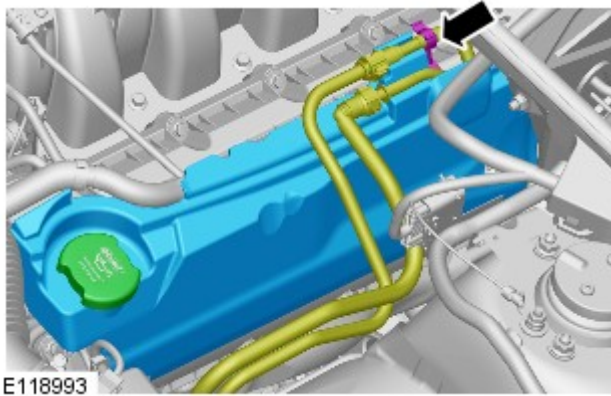

10.

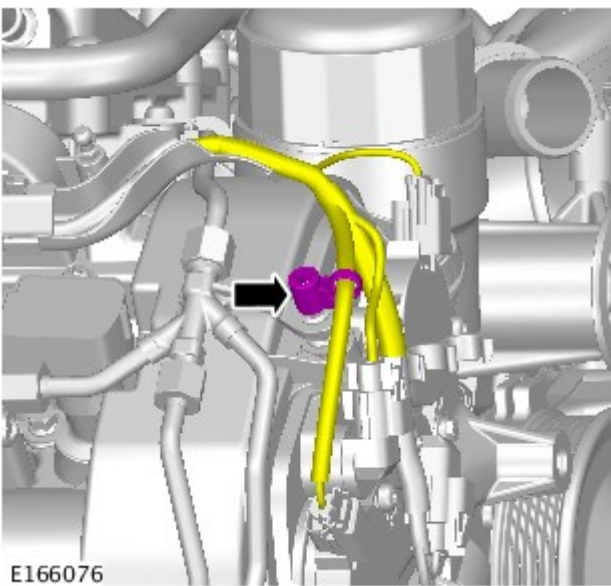

**⚠ WARNING:**

Do not smoke or carry lighted tobacco or open flame of any type when working on or near any fuel related components. Highly flammable vapors are always present and may ignite. Failure to follow these instructions may result in personal injury.

**ⓘ CAUTIONS:**

- Be prepared to collect escaping fuel.
- Before disconnecting any components, make sure the area is clean and free from foreign material. When disconnected all openings must be sealed.
- This fuel pipe can be re-used, inspect for signs of damage. Renew if necessary.

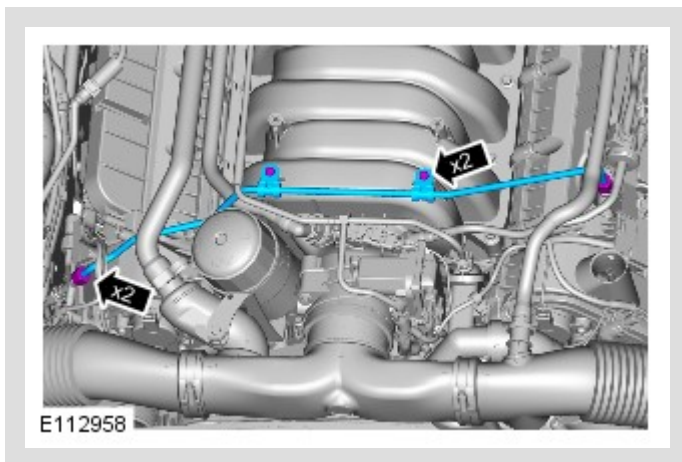

12.

**!** CAUTIONS:

- Be prepared to collect escaping fuel.
- Before disconnecting any components, make sure the area is clean and free from foreign material. When disconnected all openings must be sealed.

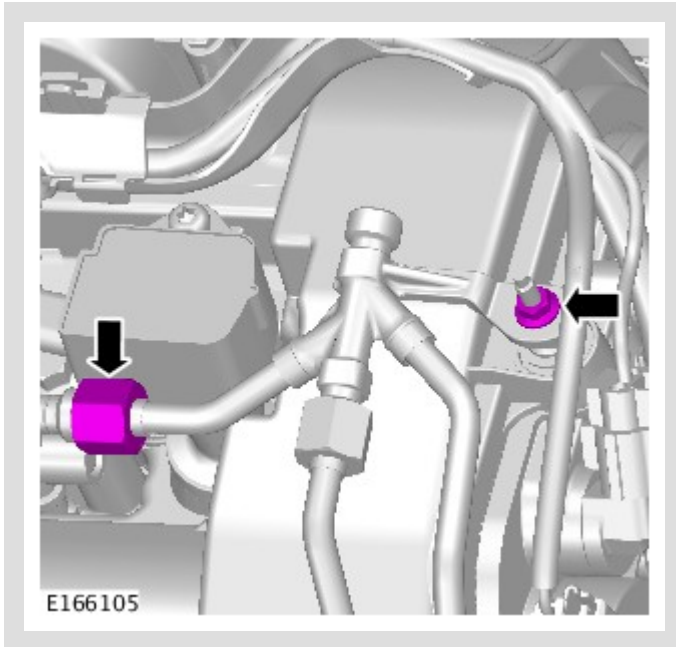

13. Refer to: [Crankshaft Pulley](#) (303-01B Engine - V8 N/A 5.0L Petrol, Removal and Installation).

14.

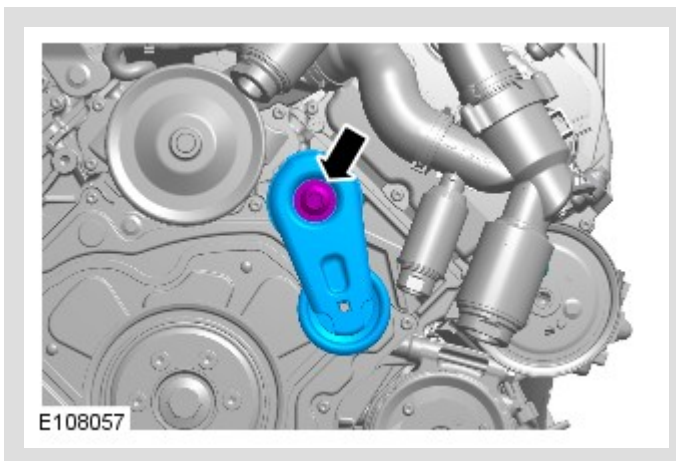

15.

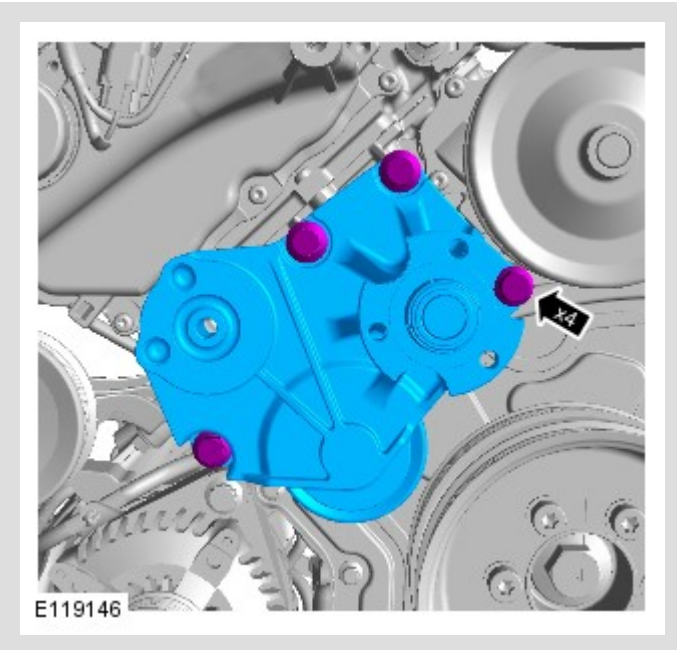

Remove the FEAD belt.

16. Remove the front right wheel and tire.

17. Refer to: [Engine Undershield](#) (501-02 Front End Body Panels, Removal and Installation).

18.

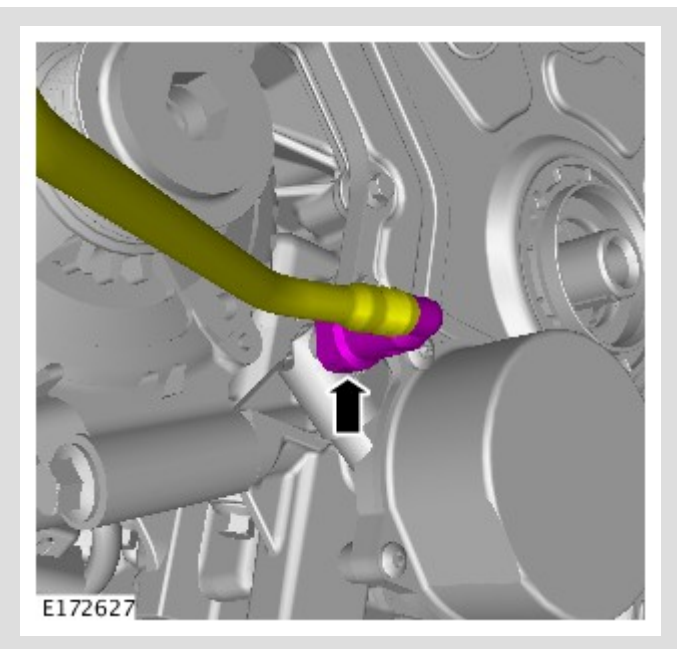

19.

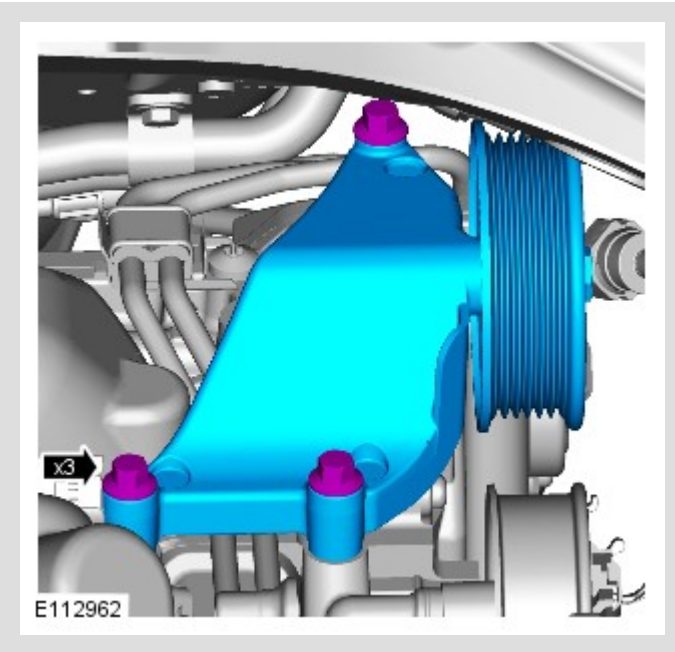

20.

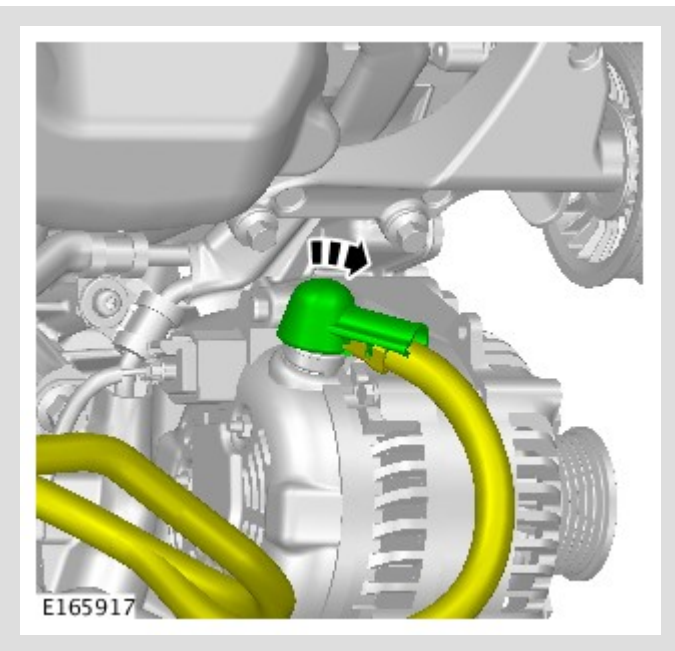

21.

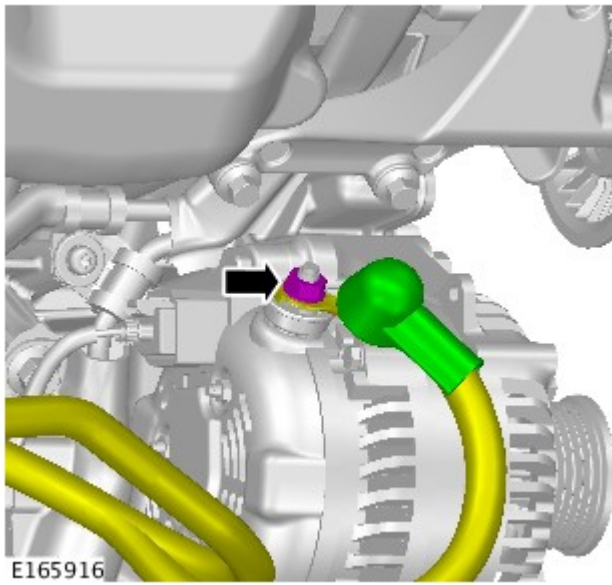

22.

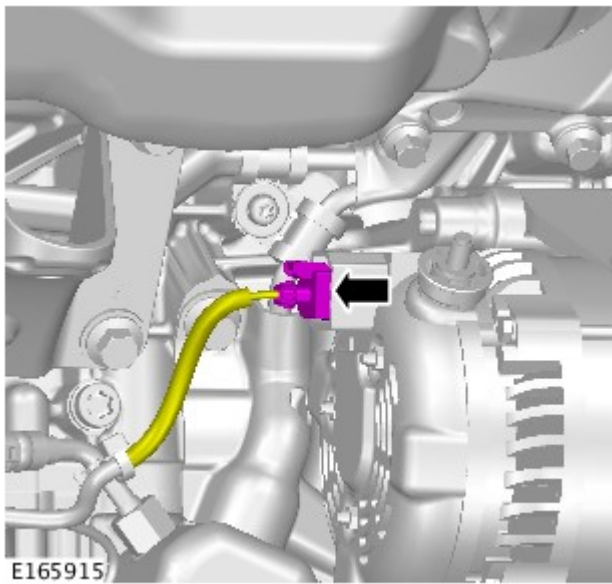

23.

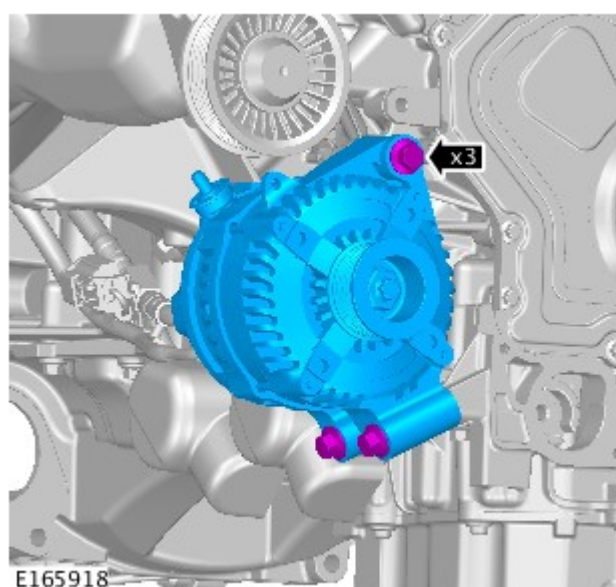

24.

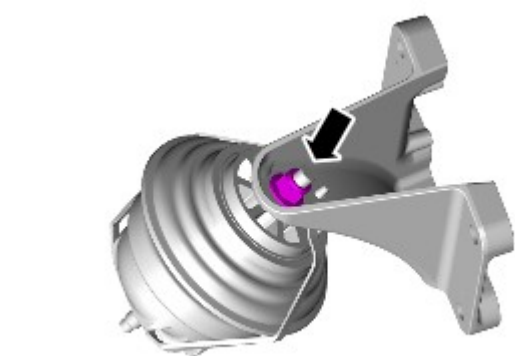

25.

**⚠ CAUTION:**

Use a wooden block to protect the oil pan when supporting the engine.

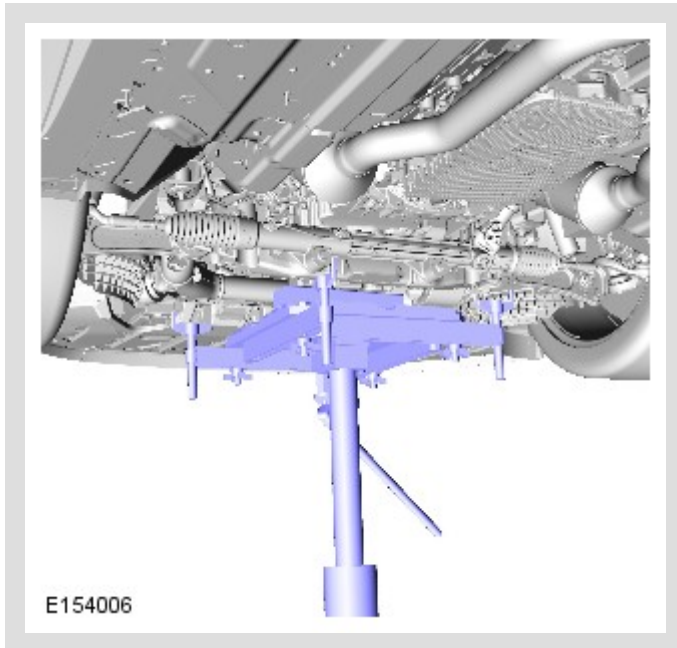

Using a suitable hydraulic jack, support the engine.

26.

**△ NOTE:**

Engine shown removed for clarity.

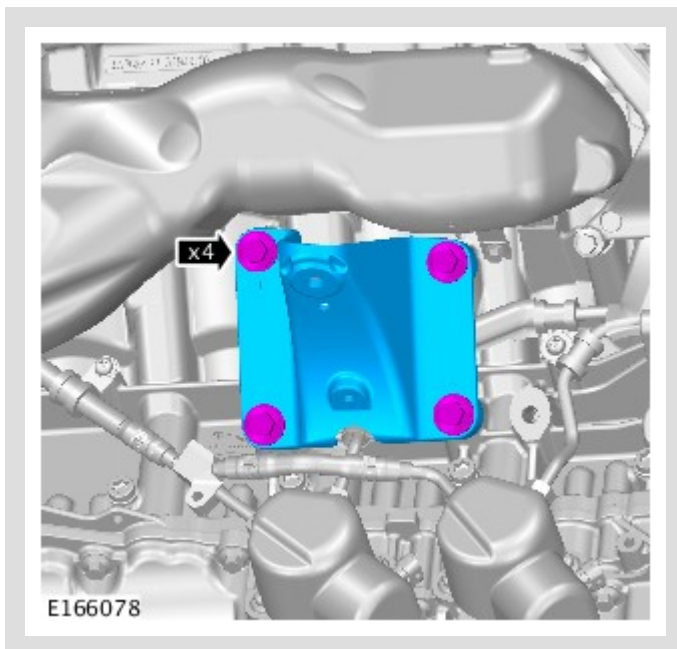

Remove the component.

**!** CAUTIONS:

- Remove and discard the high-pressure fuel supply lines.
- Be prepared to collect escaping fuel.
- Before disconnecting any components, make sure the area is clean and free from foreign material. When disconnected all openings must be sealed.

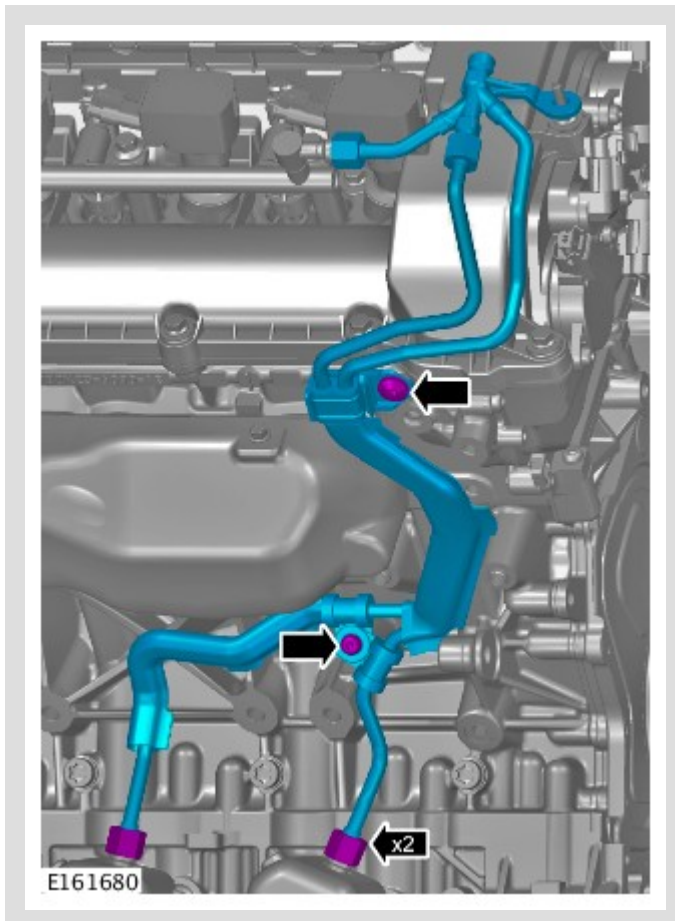

**!** CAUTIONS:

- Install new high-pressure fuel supply lines.
- Do not fully install the component at this stage.
- Do not remove the blanking caps at this stage.

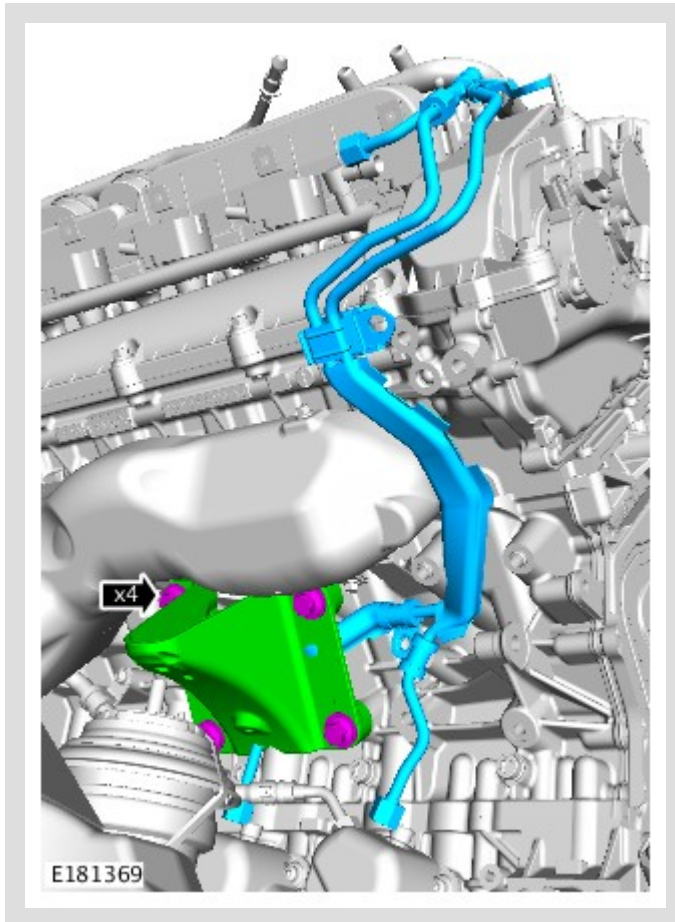

Install new high-pressure fuel supply lines. Loosely position the high pressure fuel pipes but do not tighten the unions at this stage.

Renew Part: *Fuel rail supply pipe(s)* Quantity: 1.

29.

 **NOTE:**

Engine shown removed for clarity.

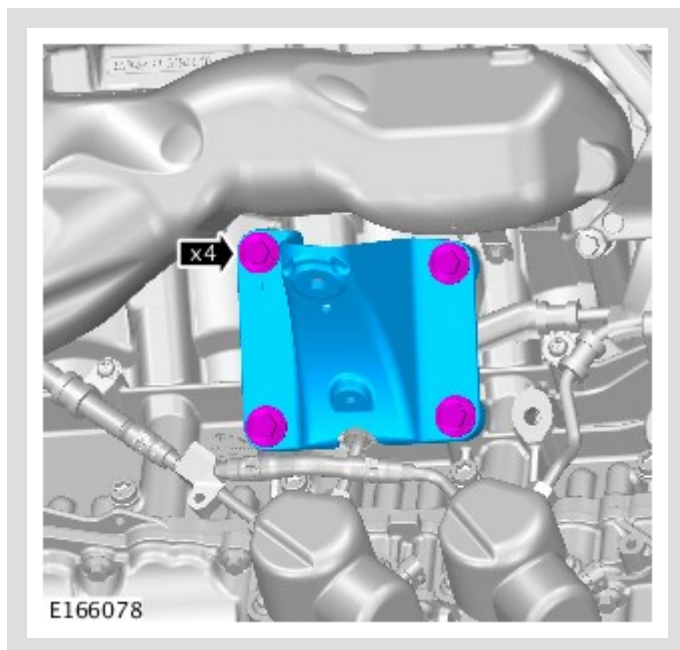

Install the engine mount.

*Torque: 48 Nm*

30.

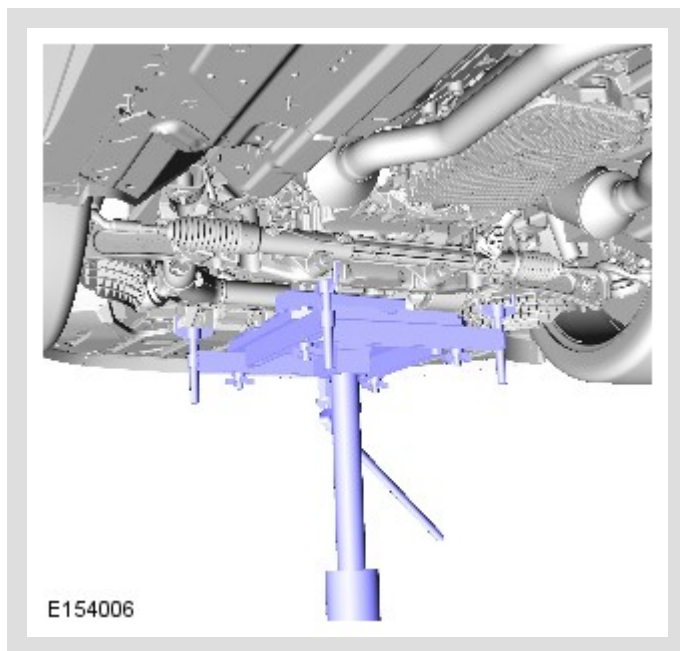

Remove the special tool.

31.

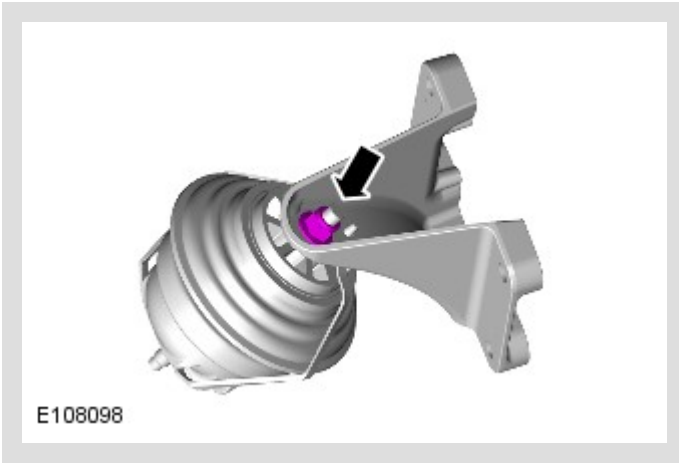

*Torque: 48 Nm*

32.

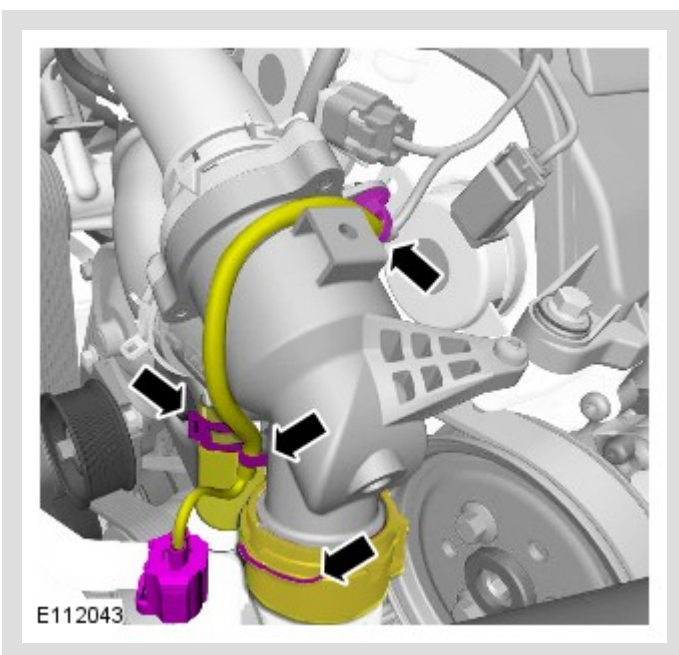

33.

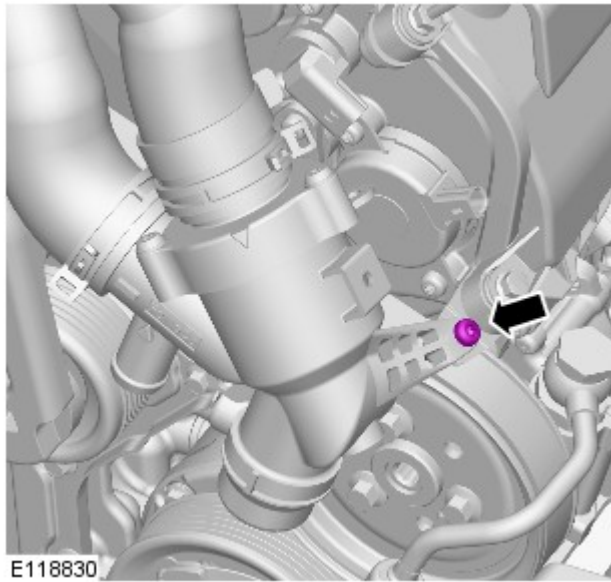

E118830

34.

 **NOTE:**

Some variation in the illustrations may occur, but the essential information is always correct.

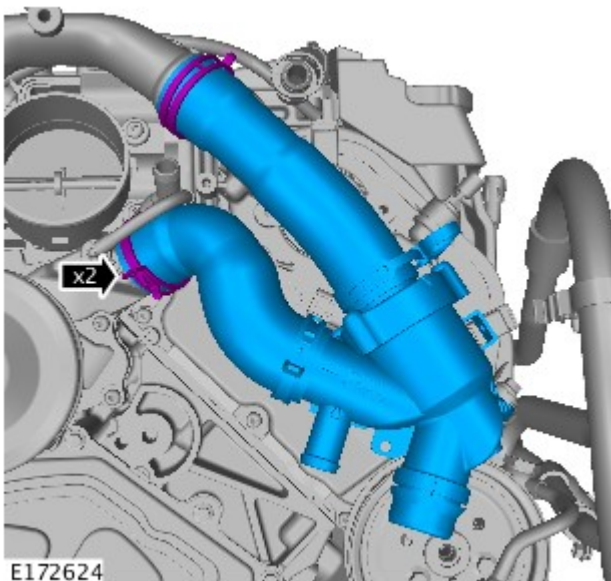

E172624

35.

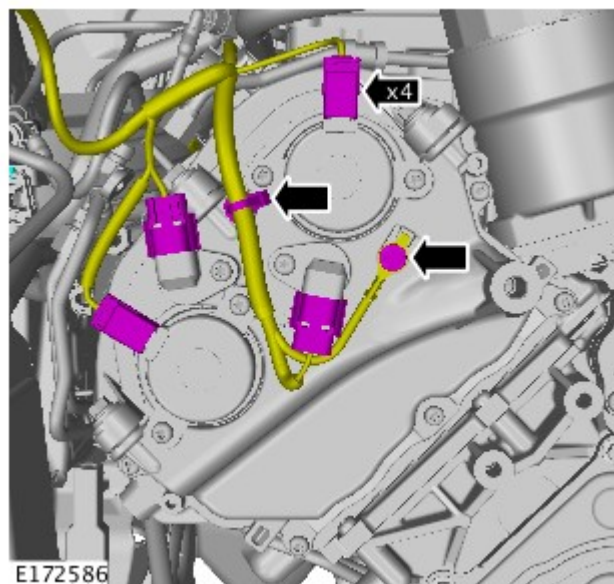

36.

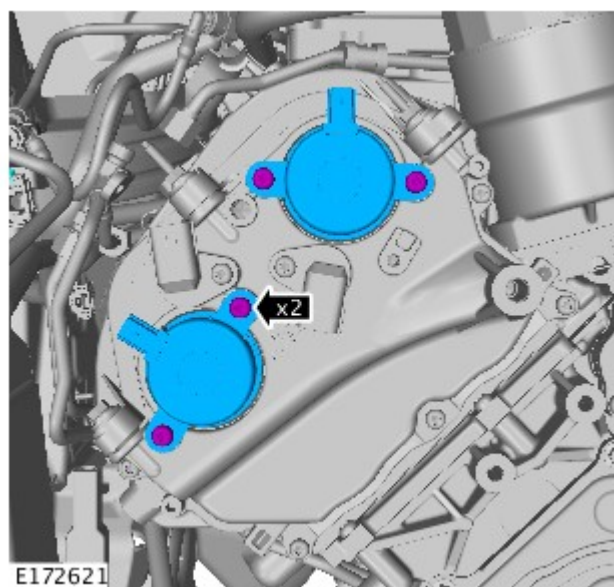

37.

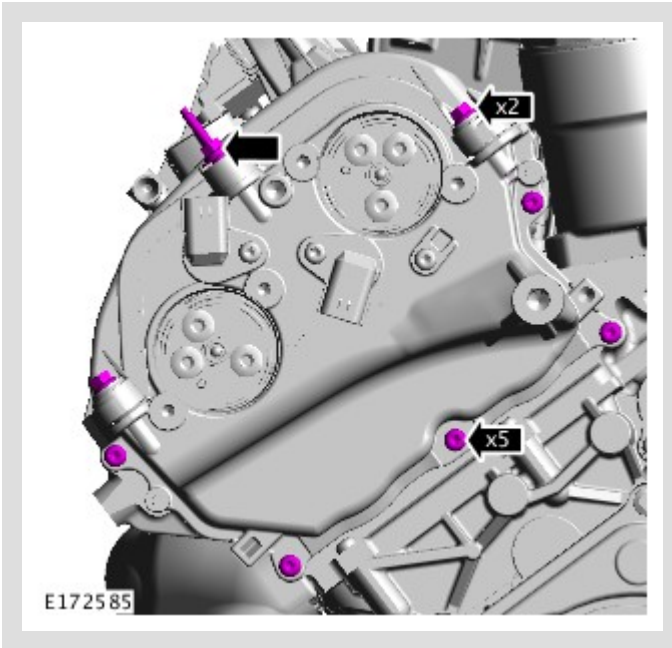

38.

**⚠ CAUTION:**

Take extra care not to damage the component.

**⚠ NOTE:**

Make sure to use the aluminum lug provided on the timing cover to lever against.

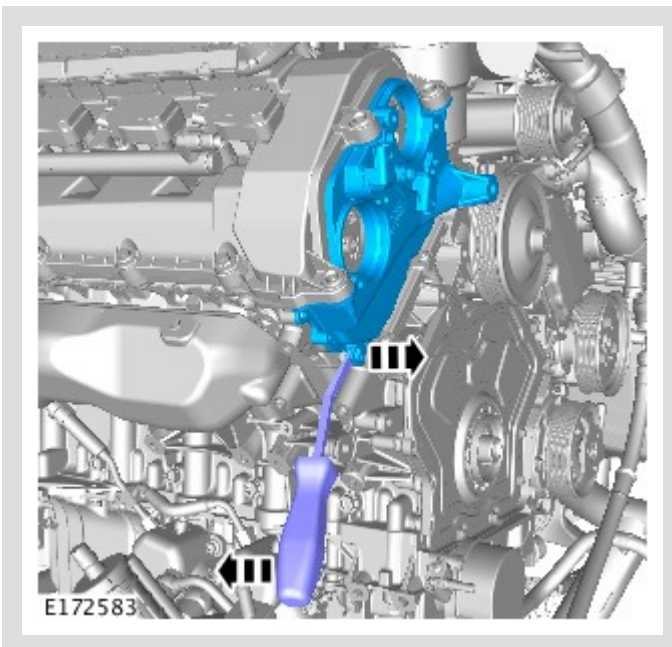

39.

**⚠ CAUTION:**

Using a suitable tool, lock the component.

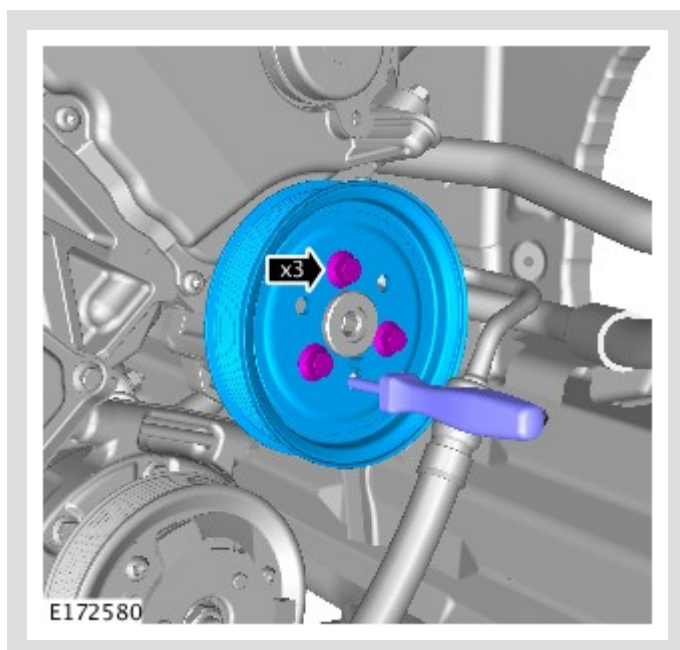

40.

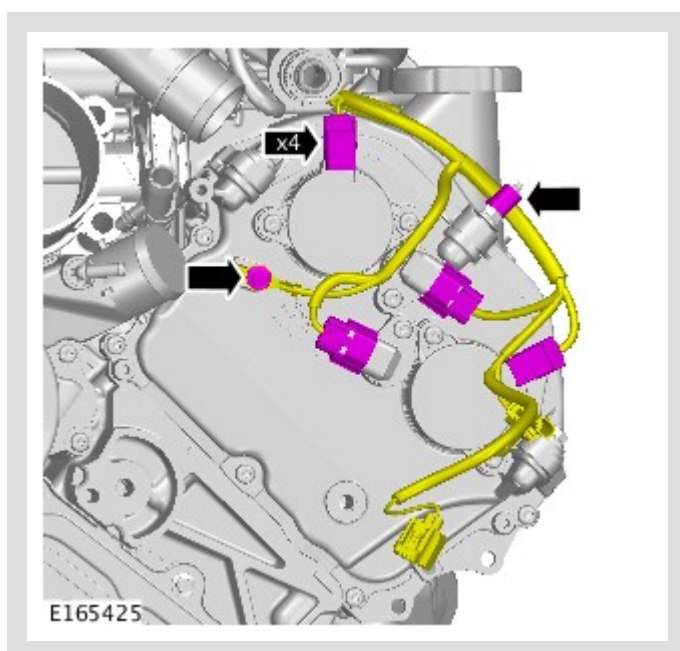

41.

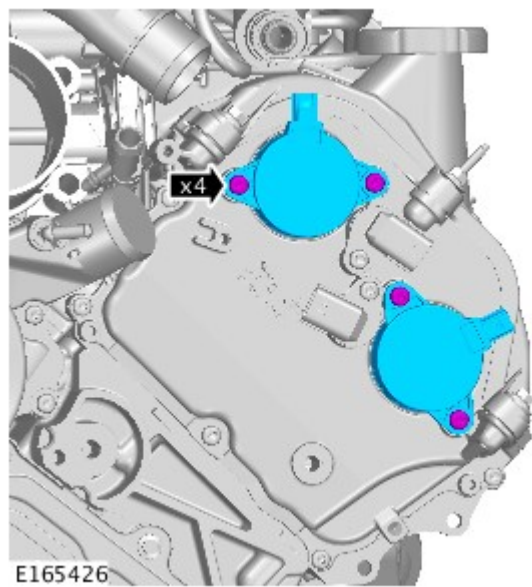

42.

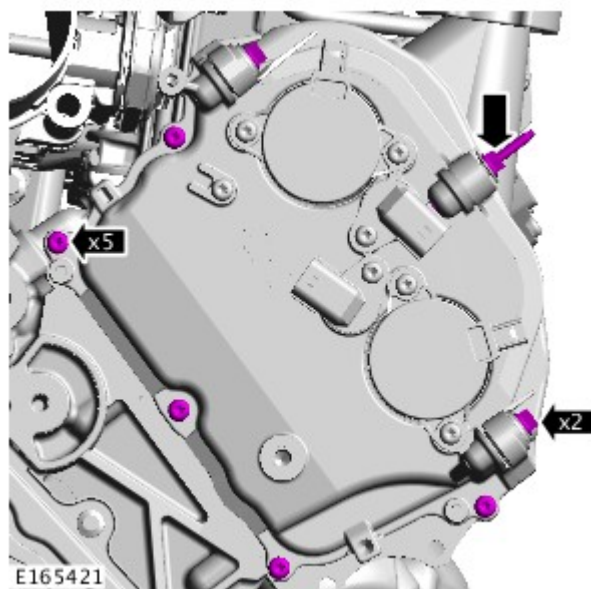

43.

**⚠ CAUTION:**

Take extra care not to damage the component.

**△ NOTE:**

Make sure to use the aluminum lug provided on the timing cover to lever against.

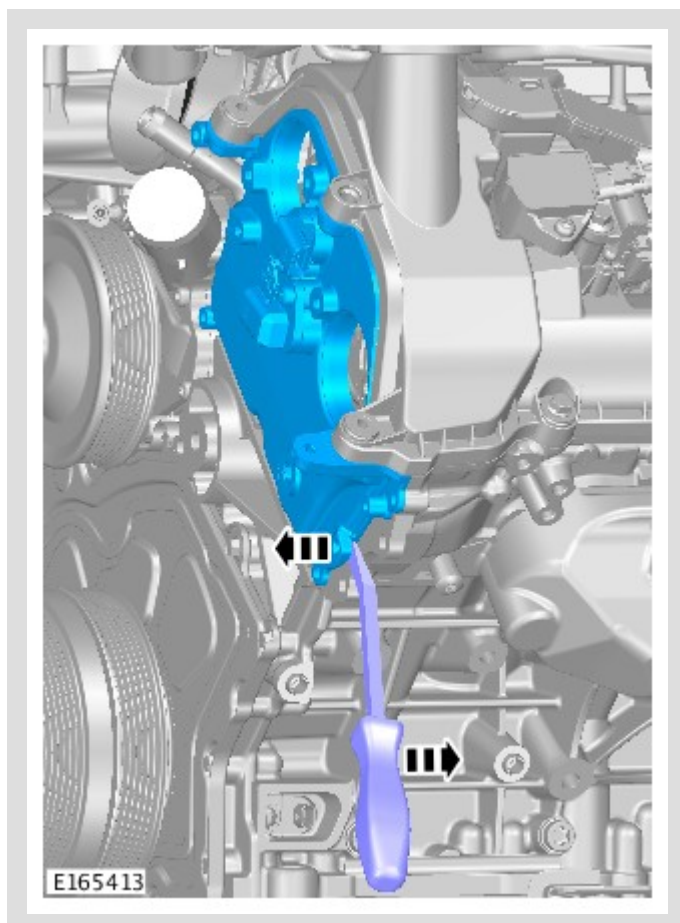

44.

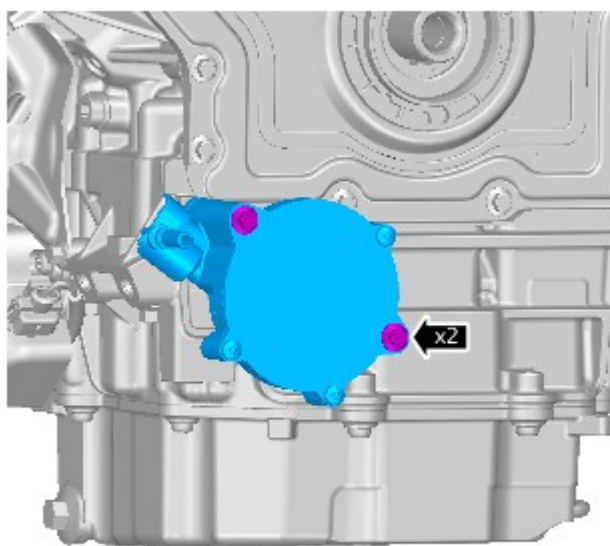

E165937

45.

**⚠ CAUTION:**

Discard the component.

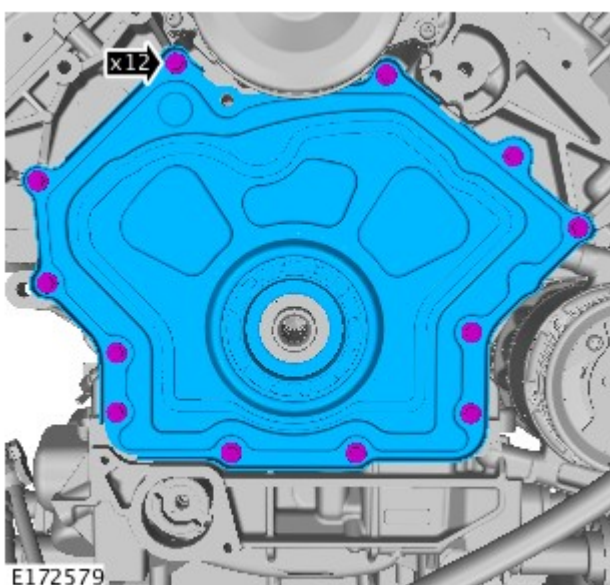

E172579

46.

**ⓘ CAUTION:**

An M16 washer must be used to prevent damage to the crankshaft on installation.

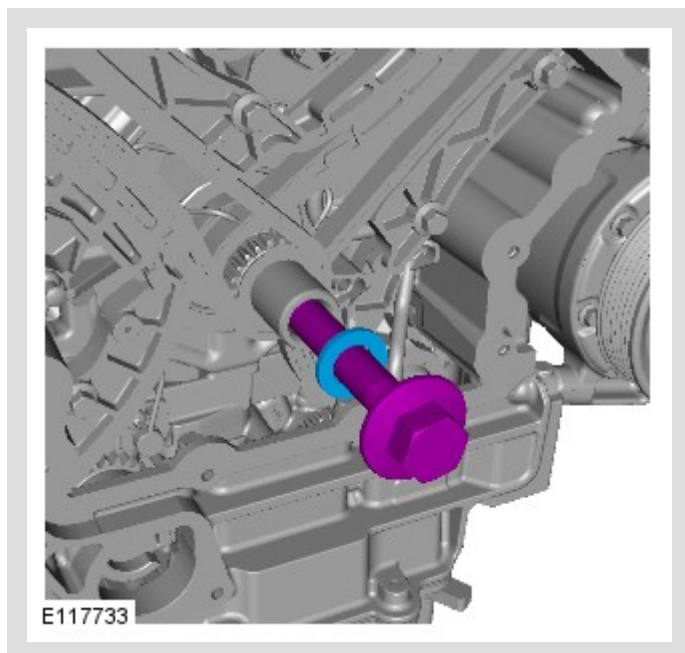

Install the crankshaft pulley bolt.

*Torque: 20 Nm*

47.

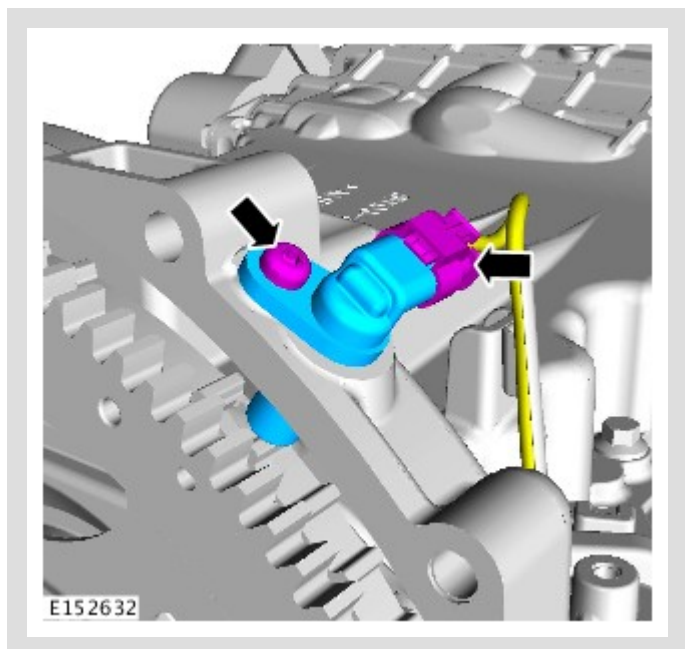

Remove the crankshaft position sensor.

**ⓘ CAUTION:**

Only rotate the crankshaft clockwise.

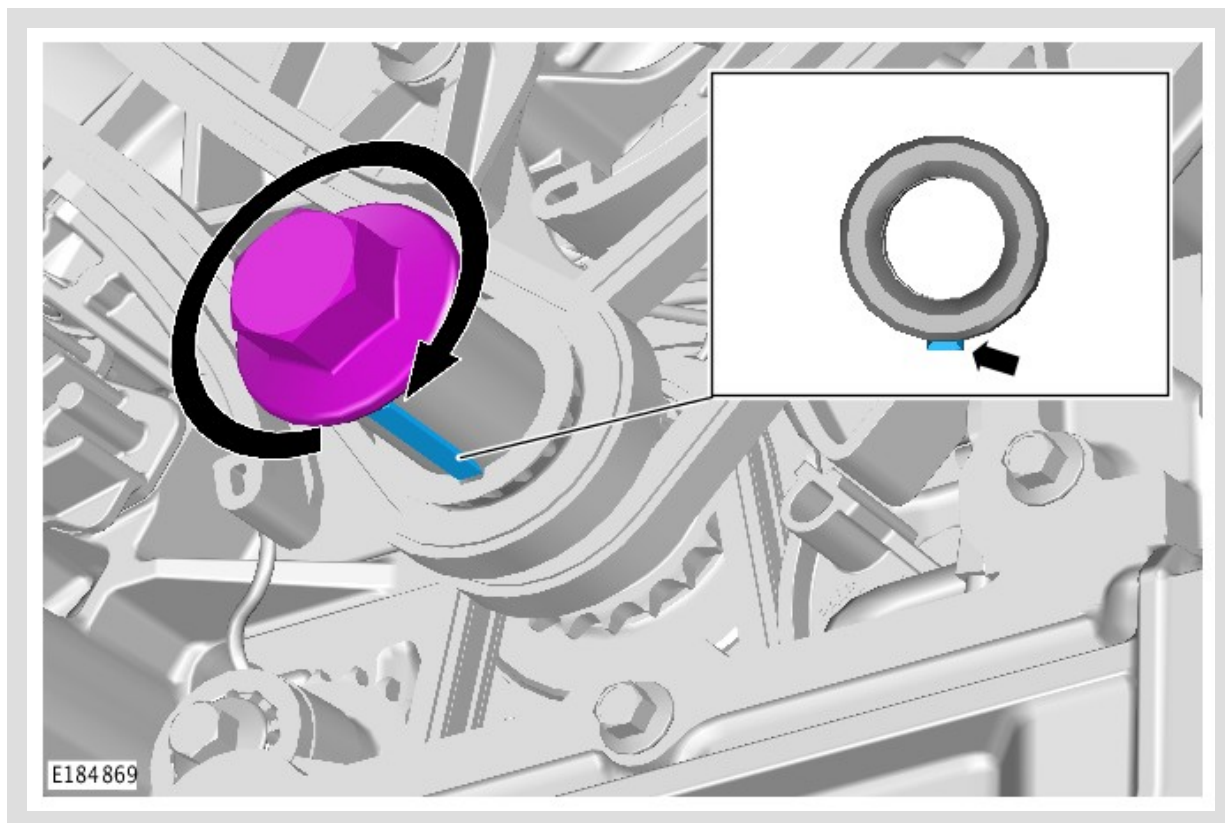

Rotate the crankshaft clockwise until the crankshaft keyway is positioned as indicated in the illustration.

49.

**!** CAUTIONS:

- Only tighten the bolt finger-tight.
- Only rotate the crankshaft clockwise.

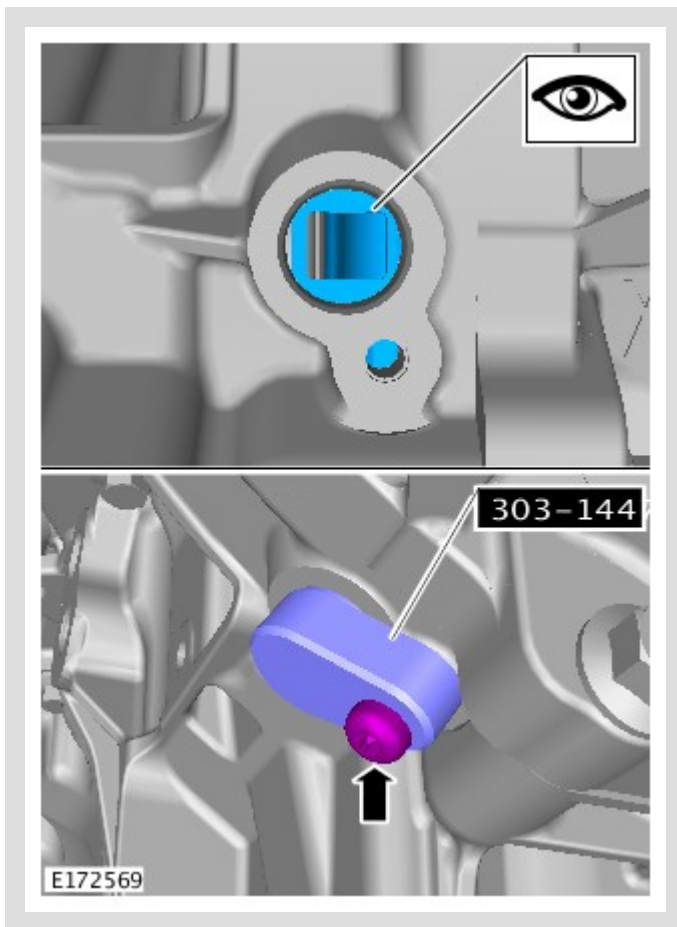

Install the crankshaft timing tool, if required rotate the engine to the correct position.

*Special Tool(s):* [303-1447](#)

50. Remove the special tool.

51.

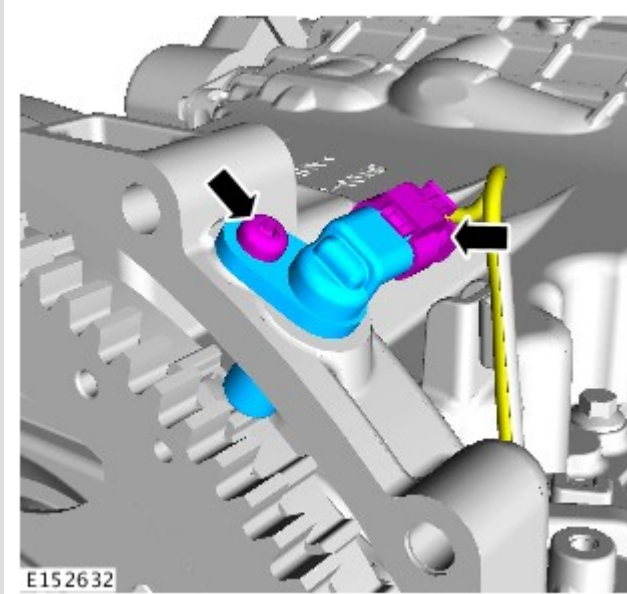

Install the crankshaft position sensor.

**Torque: 10 Nm**

52.

**⚠ CAUTION:**

Only rotate the crankshaft clockwise.

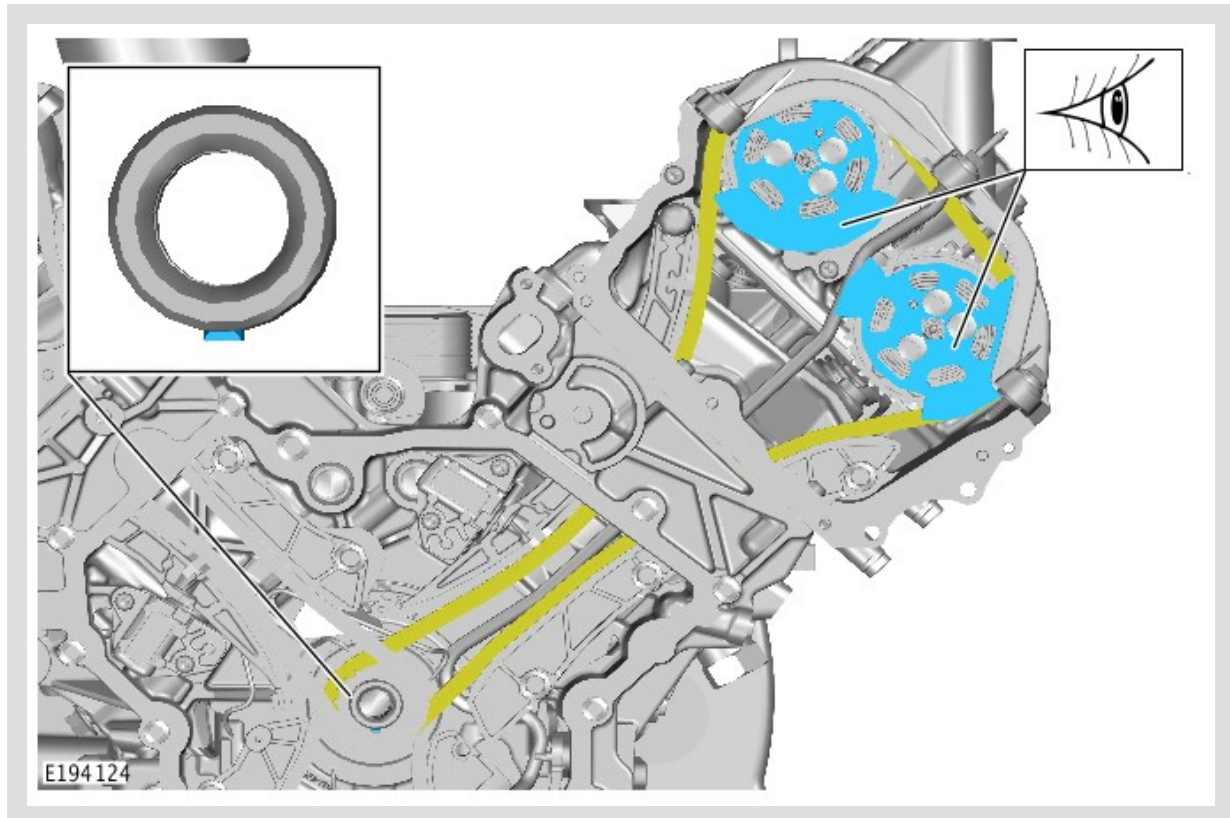

Check that the position of the Variable Valve Timing (VVT) unit and crankshaft keyway are positioned as indicated. If the VVT units are not positioned as indicated, rotate the crankshaft clockwise until the correct crankshaft keyway and VVT unit positions are achieved.

**⚠ CAUTION:**

Do not tension the tie strap at this stage.

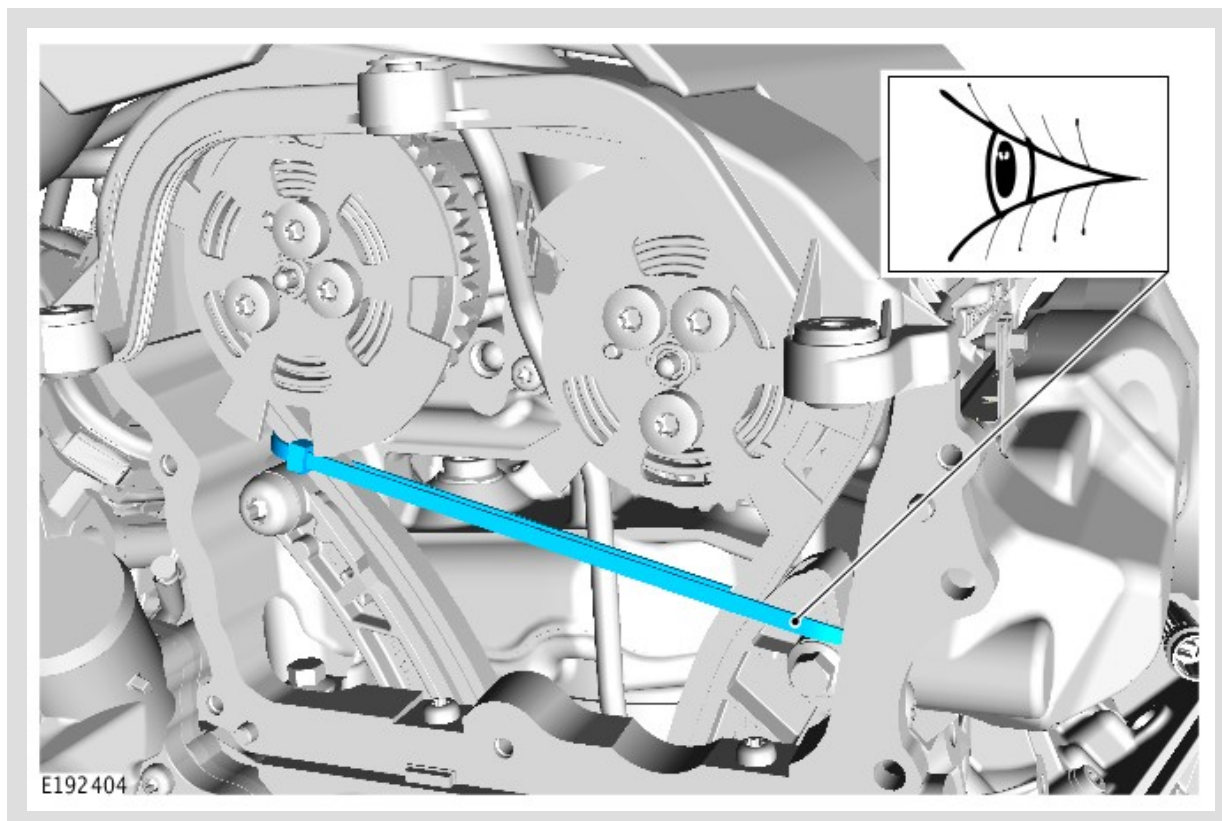

Loosely install the tie strap around the timing chain guide on the non-tensioned side and the timing chain on the tensioned side, as illustrated.

**ⓘ CAUTIONS:**

- Note the orientation of the tie strap in the illustration before applying tension.
- Make sure the tension is maintained on the timing chain.

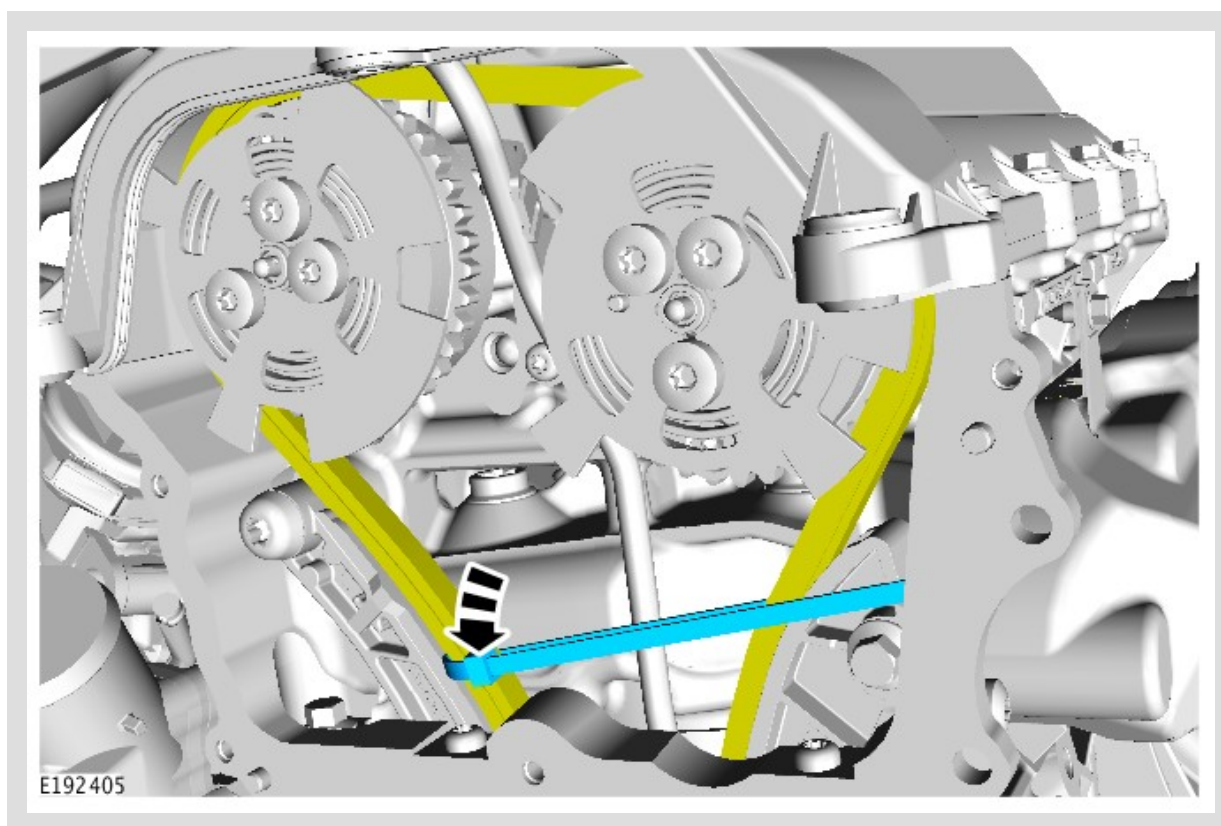

1. Carefully position the tie strap between the timing chain and the timing chain guide, as shown in the illustration.
2. Apply sufficient tension to the tie strap to limit the chain movement whilst the timing chain tensioner and timing chain guide are removed.

55.

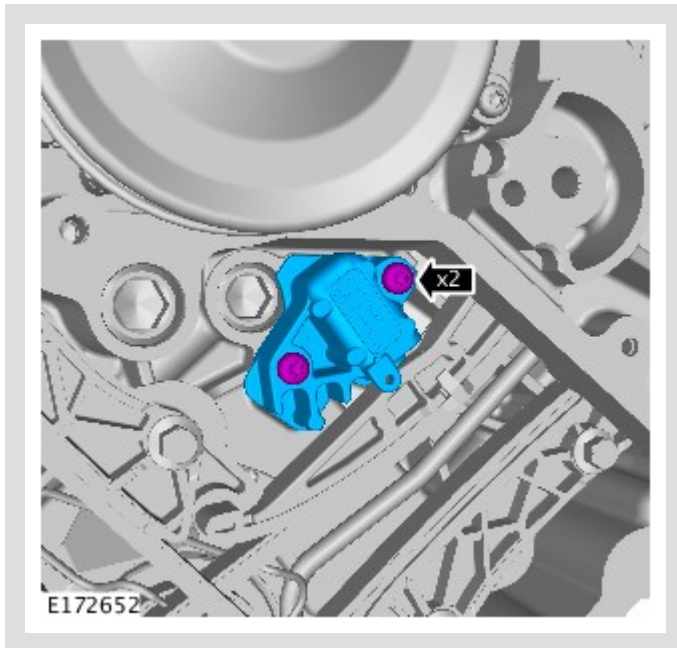

Remove the timing chain tensioner.

56.

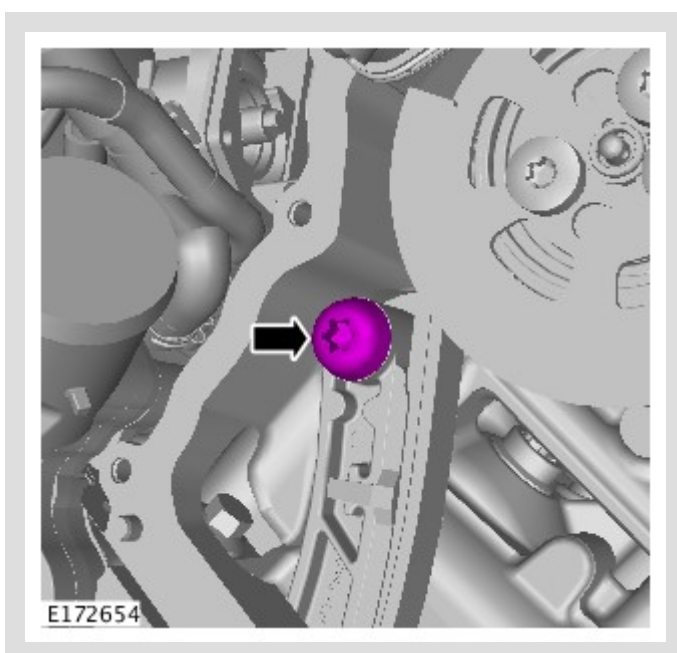

Remove the timing chain guide bolt.

57.



Remove the timing chain guide.

**!** CAUTIONS:

- If the vehicle is fitted with components shown in section 1 of the illustration, these must be replaced with components shown in section (2).
- Do not attempt to install the components shown in section 1 of the illustration, as damage to the engine may occur.

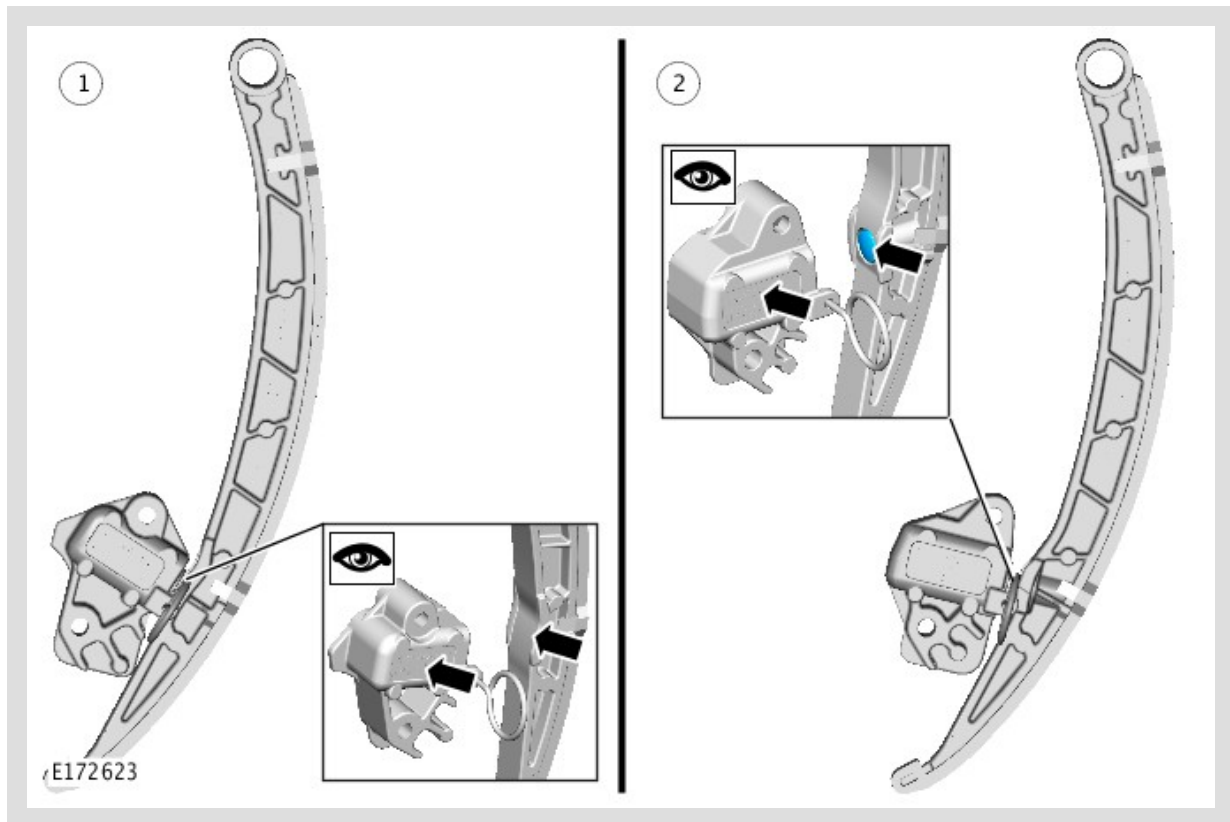

Using the illustration, identify which timing chain tensioner and guide is currently fitted to the vehicle. Make sure the vehicle is assembled using components shown in section (2) of the illustration only.

59.

**ⓘ CAUTION:**

Make sure that a new component is installed.

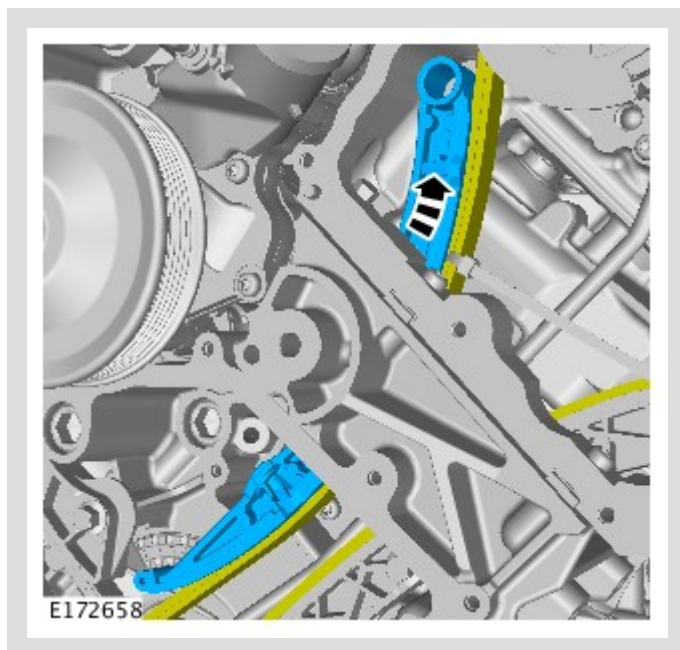

Install the timing chain guide.

60.

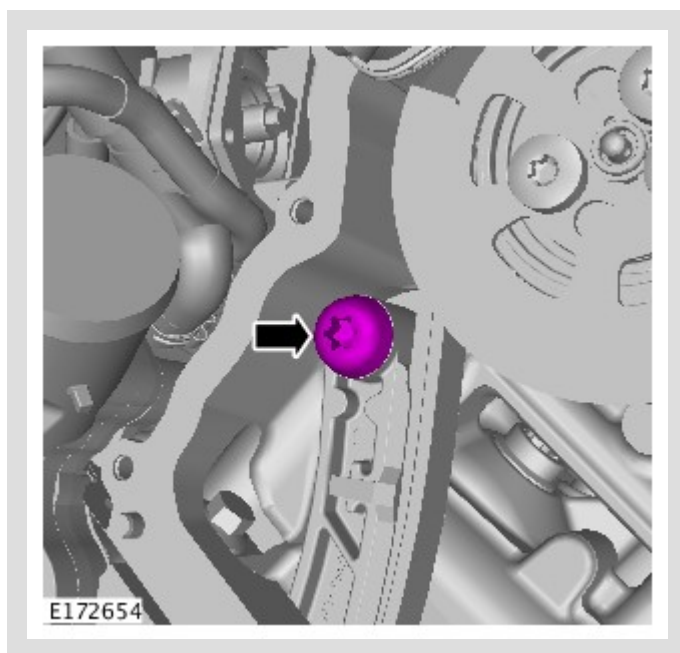

Install the timing chain guide bolt.

*Torque: 25 Nm*

61.

**!** CAUTIONS:

- If the vehicle is installed with components shown in section 1 of the illustration, these must be replaced with components shown in section (2).
- Do not attempt to install the components shown in section 1 of the illustration, as damage to the engine may occur.

Before installing the timing chain tensioners, use the illustration shown to identify which timing chain tensioner is currently fitted to the vehicle. Make sure the vehicle is assembled using components shown in section (2) of the illustration only. If a new timing chain tensioner is installed, do not deploy the tensioner pin and proceed to the next step. If the tensioner to be installed has previously been deployed, make sure the attached animation is followed to make sure the tensioner is set correctly, failure to do this may result in damage to the engine.

62.

**!** CAUTION:

Do not release the timing chain tensioner locking pin at this stage.

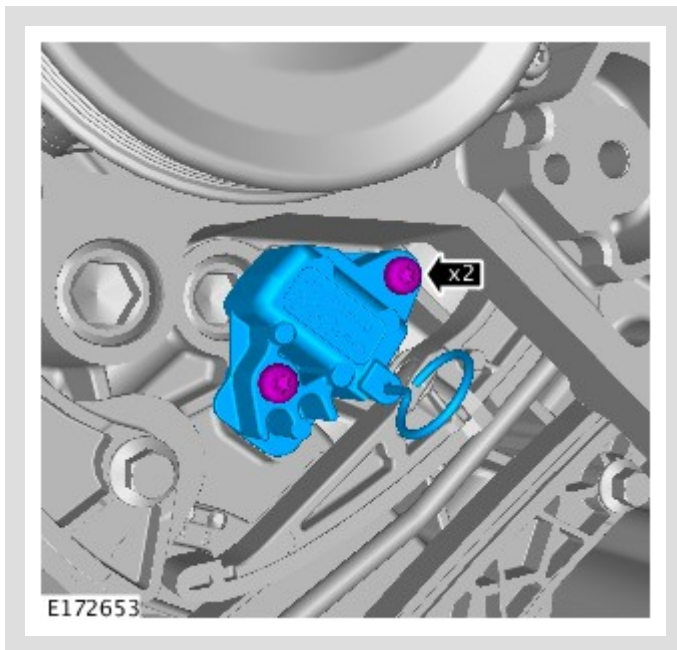

Install the timing chain tensioner.

*Torque:* **12 Nm**

63.

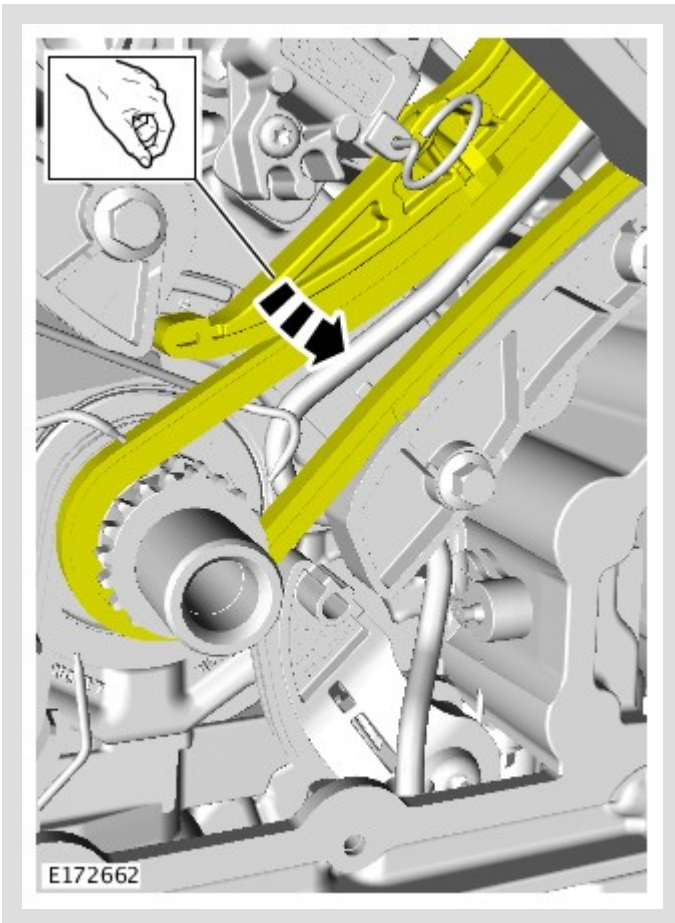

Apply and maintain tension on the component.

64.

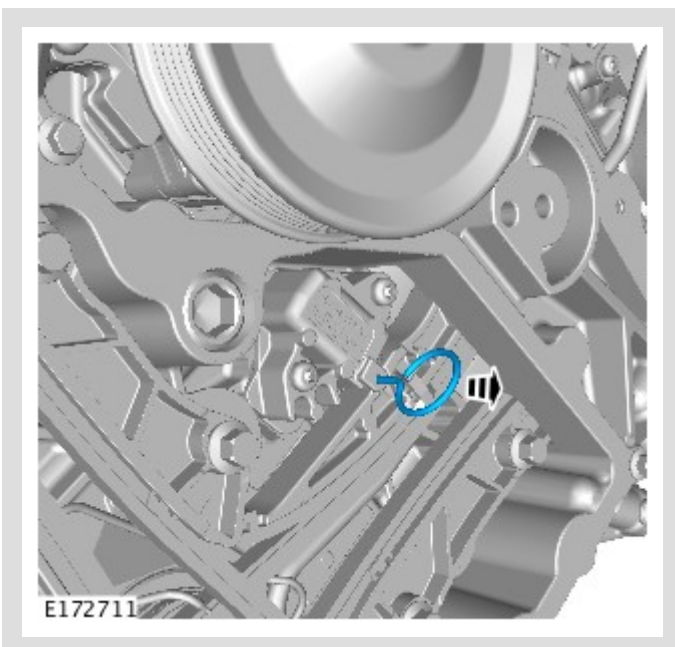

Remove the timing chain tensioner retaining pin and release the timing chain guide.

65.

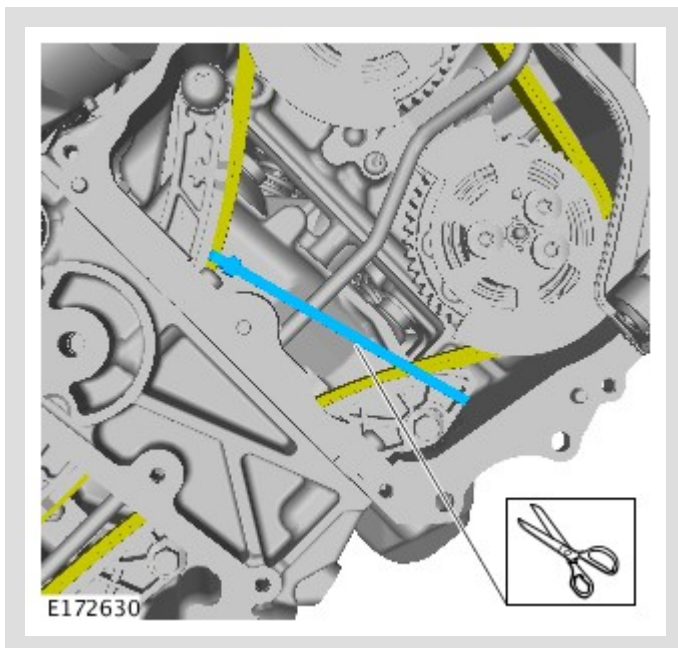

Remove and discard the tie strap.

66.

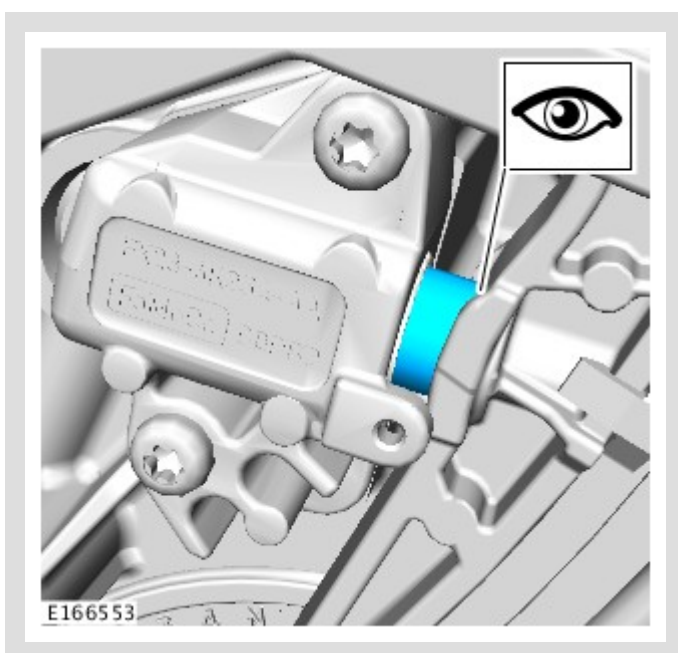

The timing chain tensioner piston should apply tension to the timing chain guide.

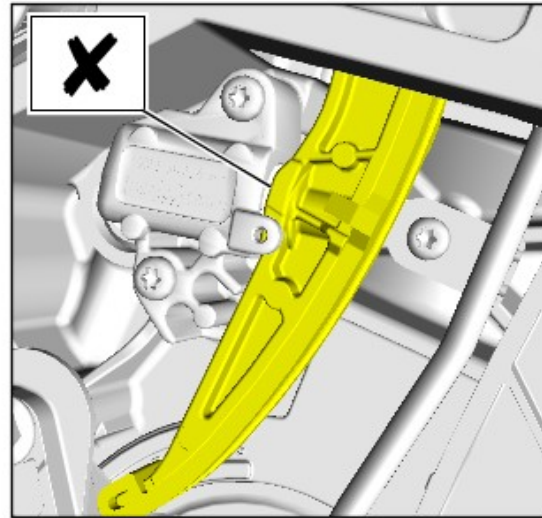
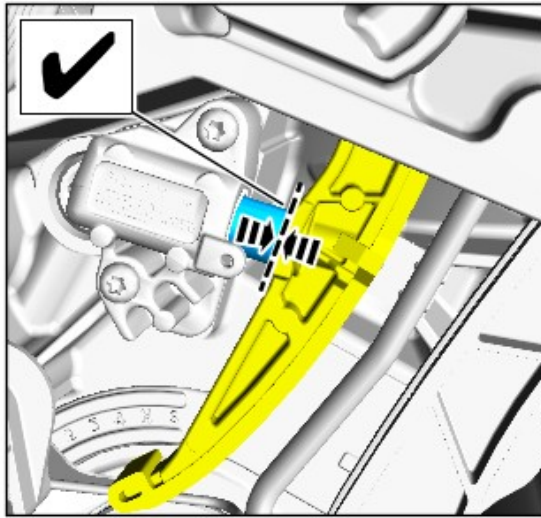

E166556

The timing chain tensioner must maintain tension on the chain guide. If the piston can be pushed back so the chain guide contacts with the body of the tensioner, the tensioner is not correct. Repeat steps 61-67.

**⚠ CAUTION:**

Only rotate the crankshaft clockwise.

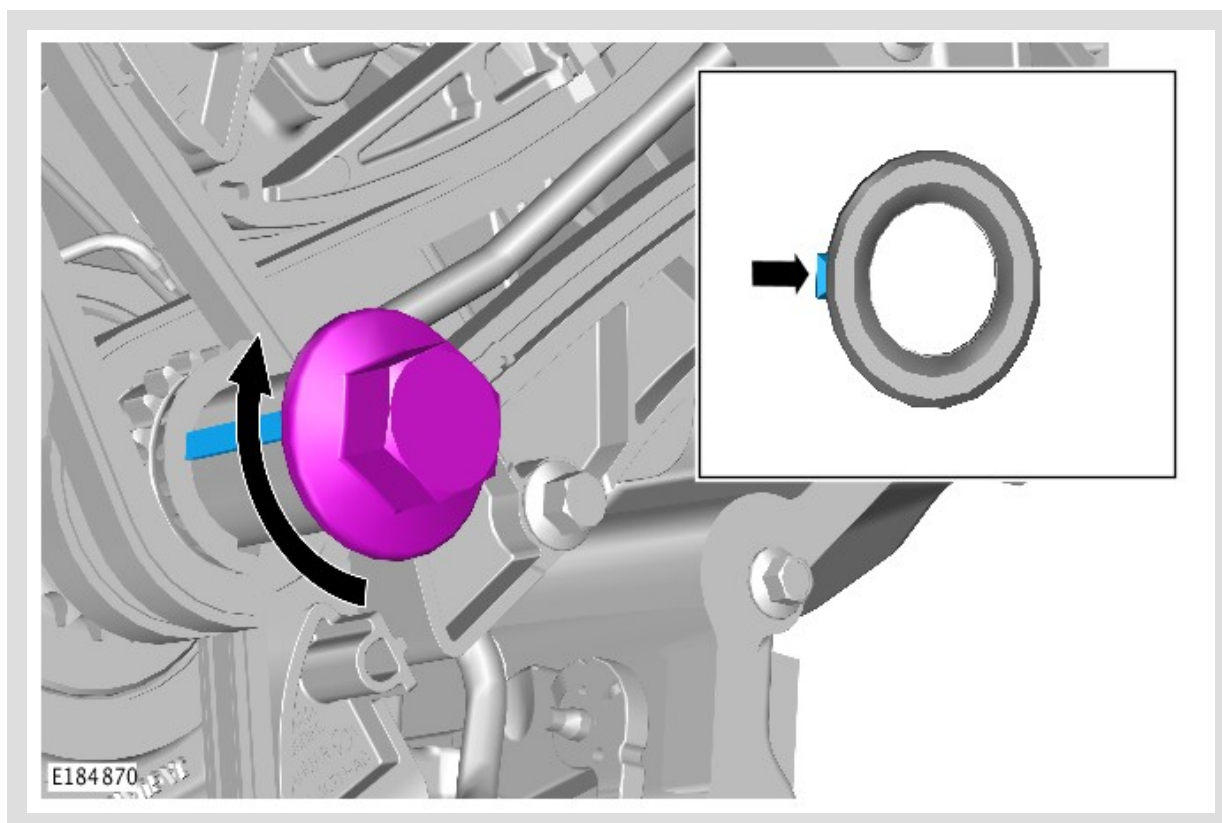

Rotate the crankshaft clockwise 90 degrees until the crankshaft keyway is positioned as indicated in the illustration.

**⚠ CAUTION:**

Only rotate the crankshaft clockwise.

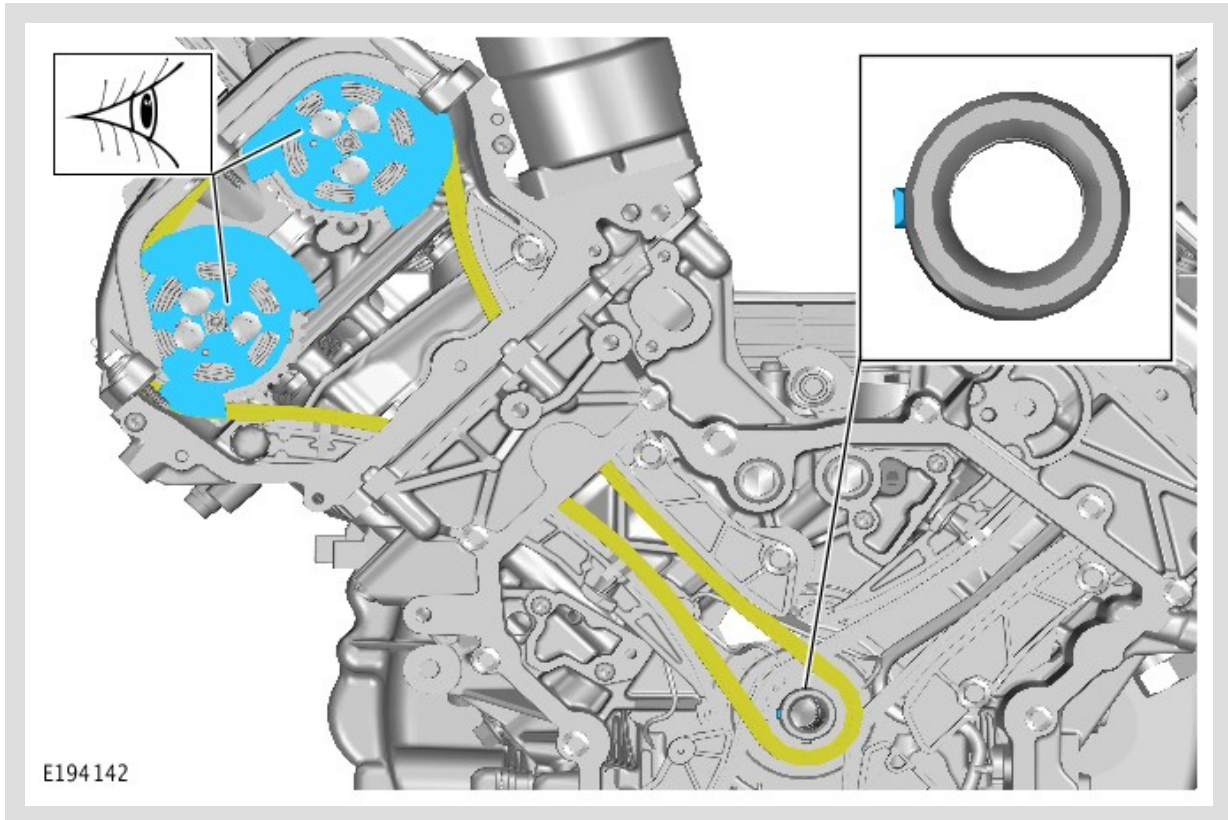

Check that the position of the Variable Valve Timing (VVT) unit and crankshaft keyway are positioned as indicated. If the VVT units are not positioned as indicated, rotate the crankshaft clockwise until the correct crankshaft keyway and VVT unit positions are achieved.

70.

**⚠ CAUTION:**

Do not tension the tie strap at this stage.

**△ NOTE:**

Right side.

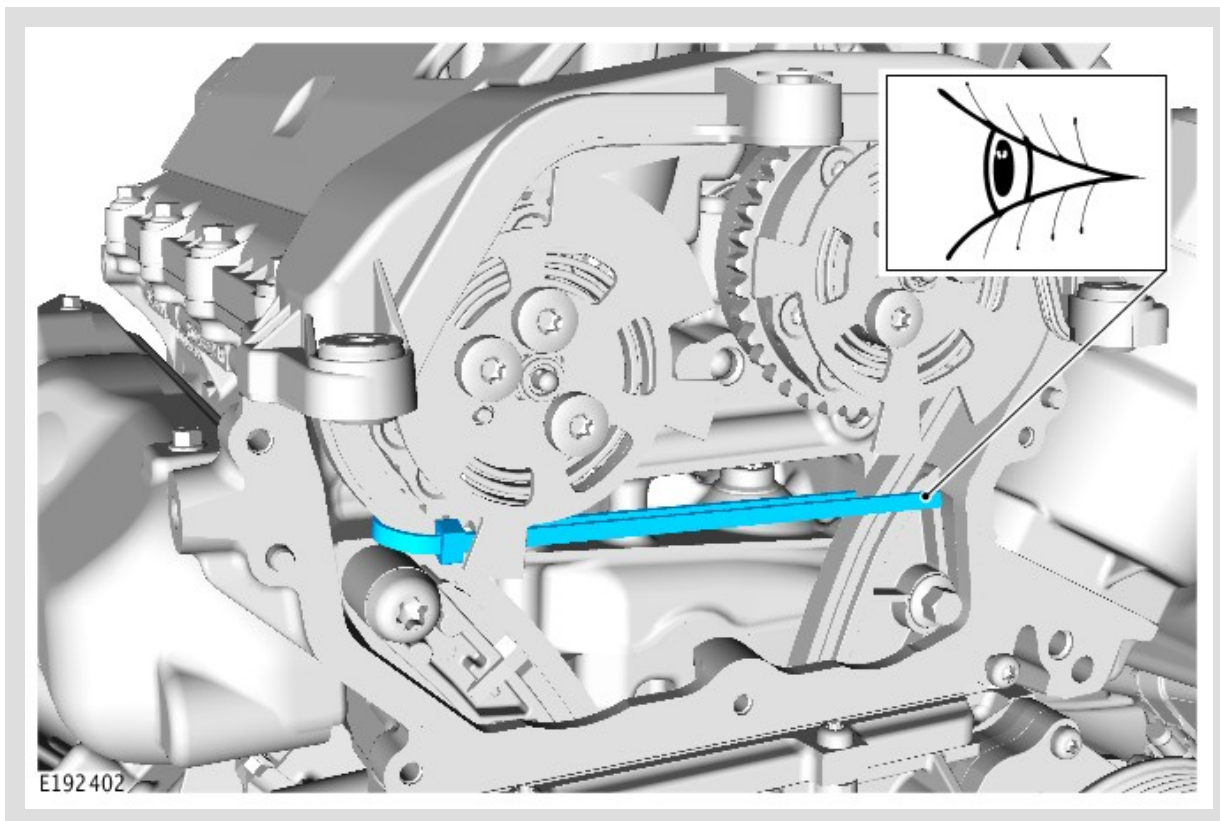

Loosely install the tie strap around the timing chain guide on the non-tensioned side and the timing chain on the tensioned side, as illustrated.

**ⓘ CAUTIONS:**

- Note the orientation of the tie strap in the illustration before applying tension.
- Make sure the tension is maintained on the timing chain.

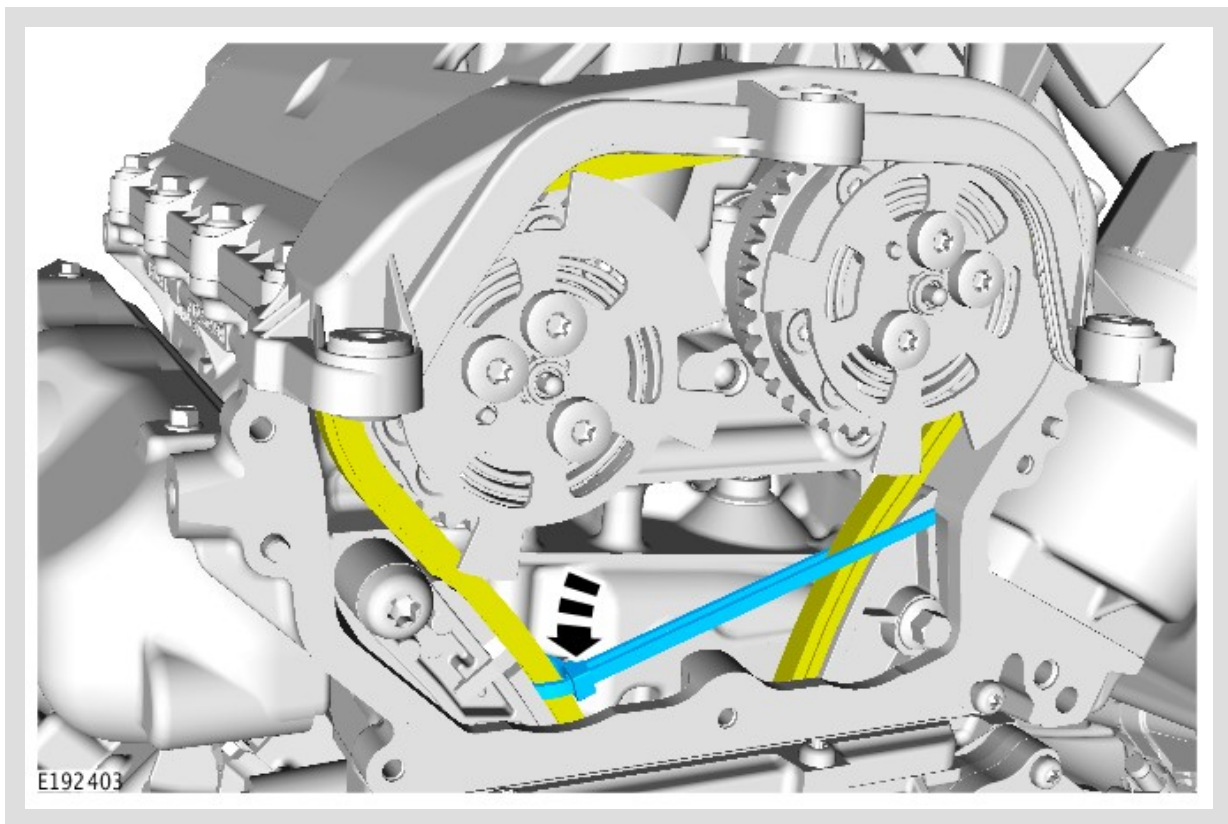

1. Carefully manipulate the tie strap between the timing chain and the timing chain guide, to the position illustrated.
2. Apply sufficient tension to the tie strap; allowing the timing chain to remain under tension, whilst the timing chain tensioner and timing chain guide are removed.

72.

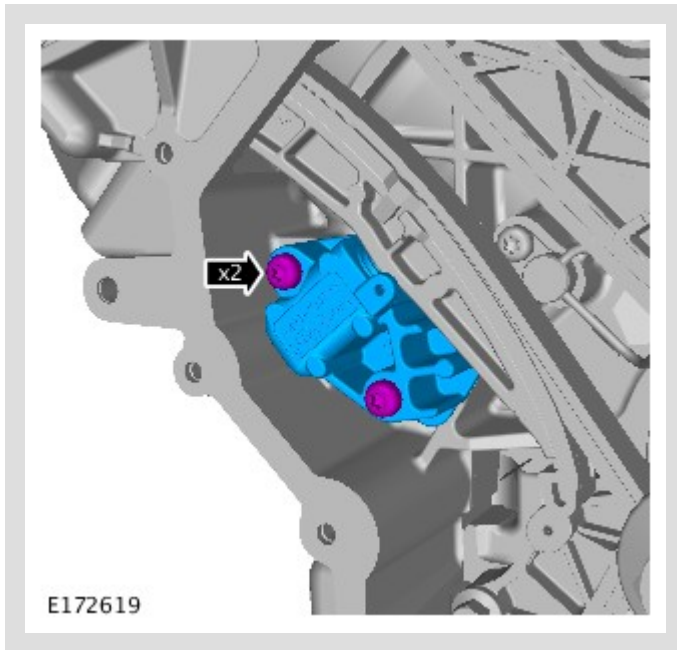

Remove the timing chain tensioner.

73.

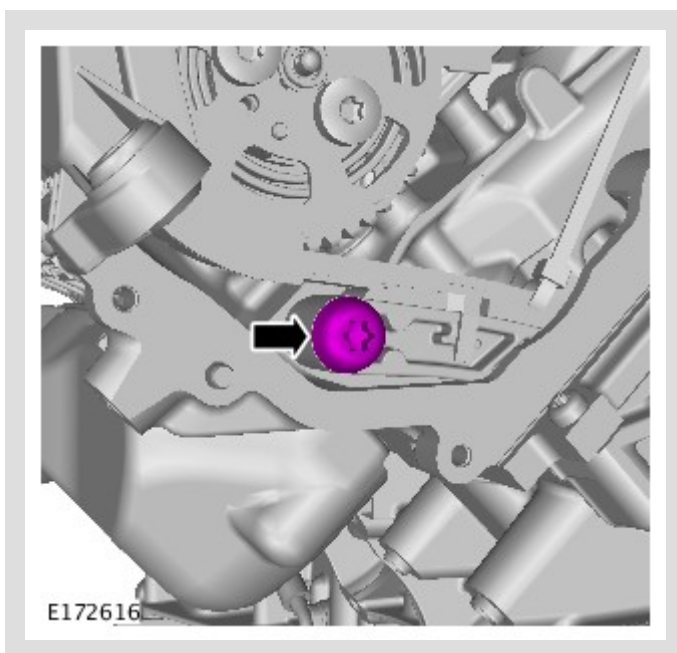

Remove the timing chain guide bolt.

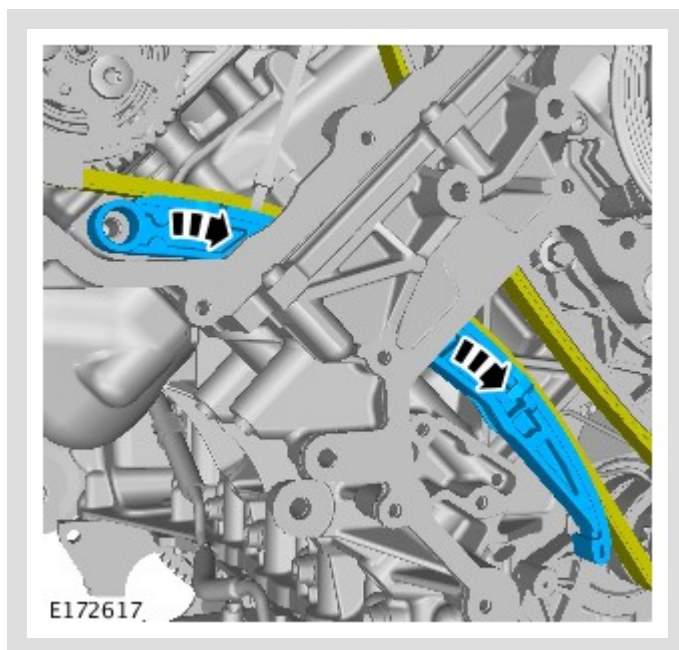

Remove the timing chain guide.

**!** CAUTIONS:

- If the vehicle is fitted with components shown in section 1 of the illustration, these must be replaced with components shown in section (2).
- Do not attempt to install the components shown in section 1 of the illustration, as damage to the engine may occur.

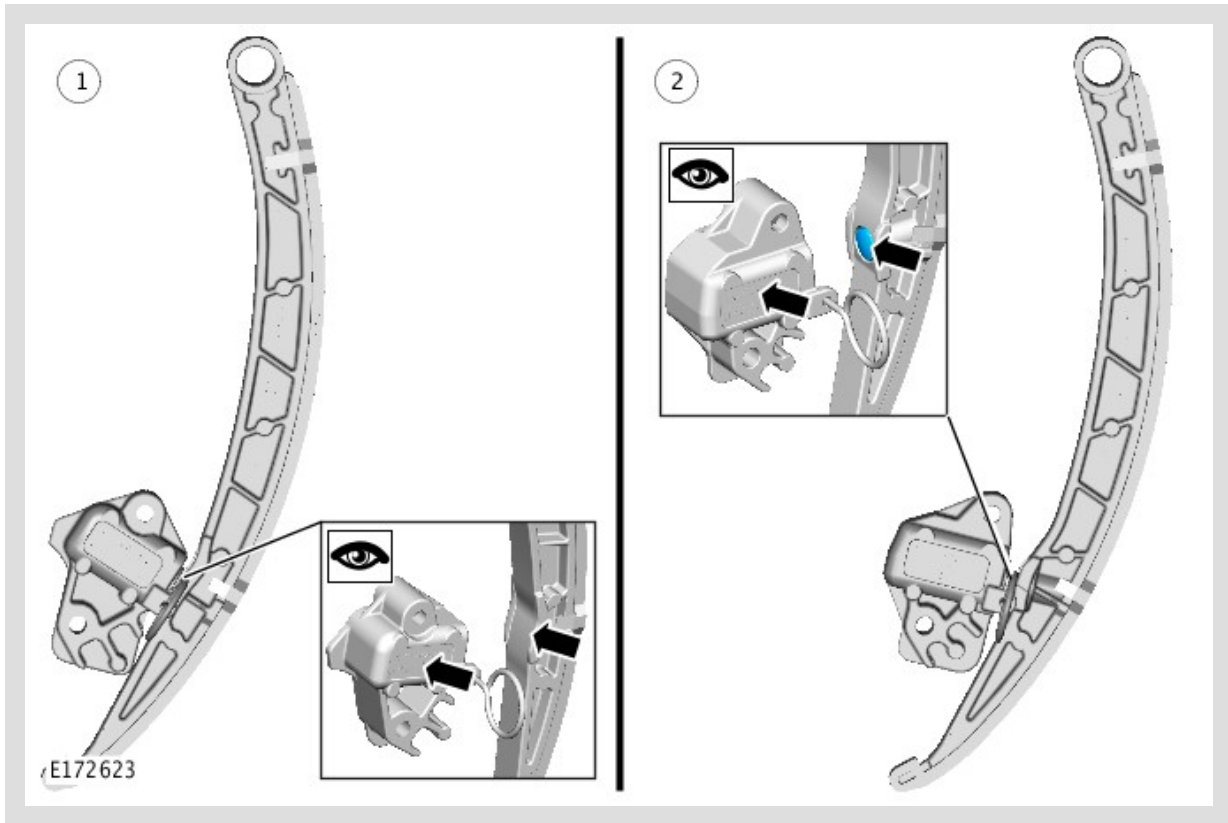

Using the illustration, identify which timing chain tensioner and guide is currently fitted to the vehicle. Make sure the vehicle is assembled using components shown in section (2) of the illustration only.

76.

**ⓘ CAUTION:**

Make sure that a new component is installed.

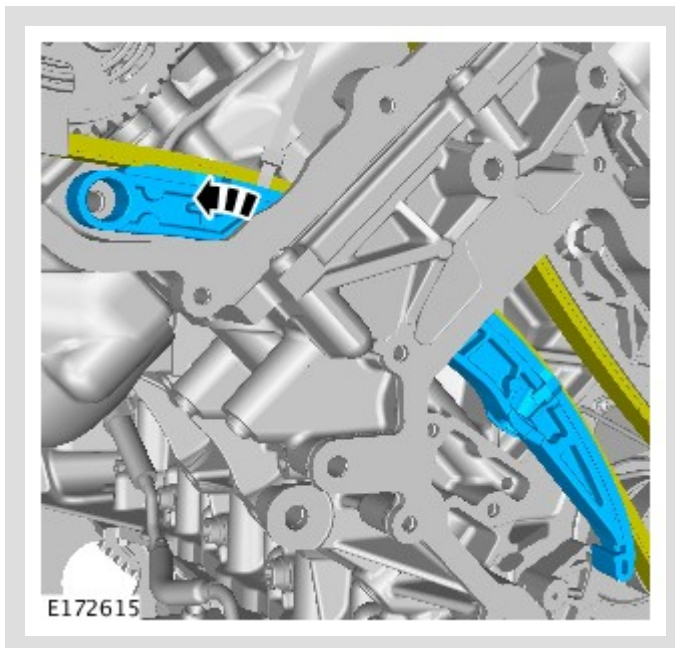

Install the timing chain guide.

77.

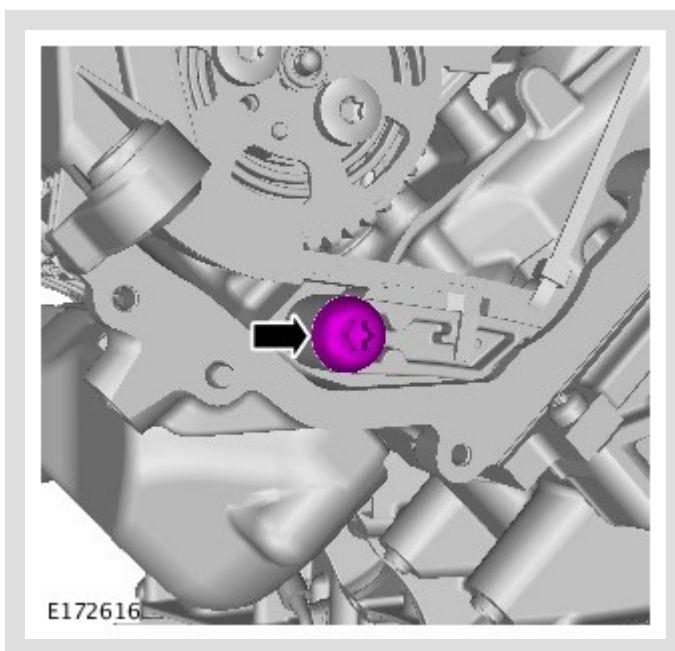

Install the timing chain guide bolt.

*Torque: 25 Nm*

78.

**!** CAUTIONS:

- If the vehicle is installed with components shown in section 1 of the illustration, these must be replaced with components shown in section (2).
- Do not attempt to install the components shown in section 1 of the illustration, as damage to the engine may occur.

Before installing the timing chain tensioners, use the illustration shown to identify which timing chain tensioner is currently fitted to the vehicle. Make sure the vehicle is assembled using components shown in section (2) of the illustration only. If a new timing chain tensioner is installed, do not deploy the tensioner pin and proceed to the next step. If the tensioner to be installed has previously been deployed, make sure the attached animation is followed to make sure the tensioner is set correctly, failure to do this may result in damage to the engine.

79.

**!** CAUTION:

Do not release the timing chain tensioner locking pin at this stage.



Before installing the timing chain tensioners, make sure the attached animation is followed to ensure the tensioner is set correctly, failure to do this may result in damage to the engine.

*Torque:* **12 Nm**

80.

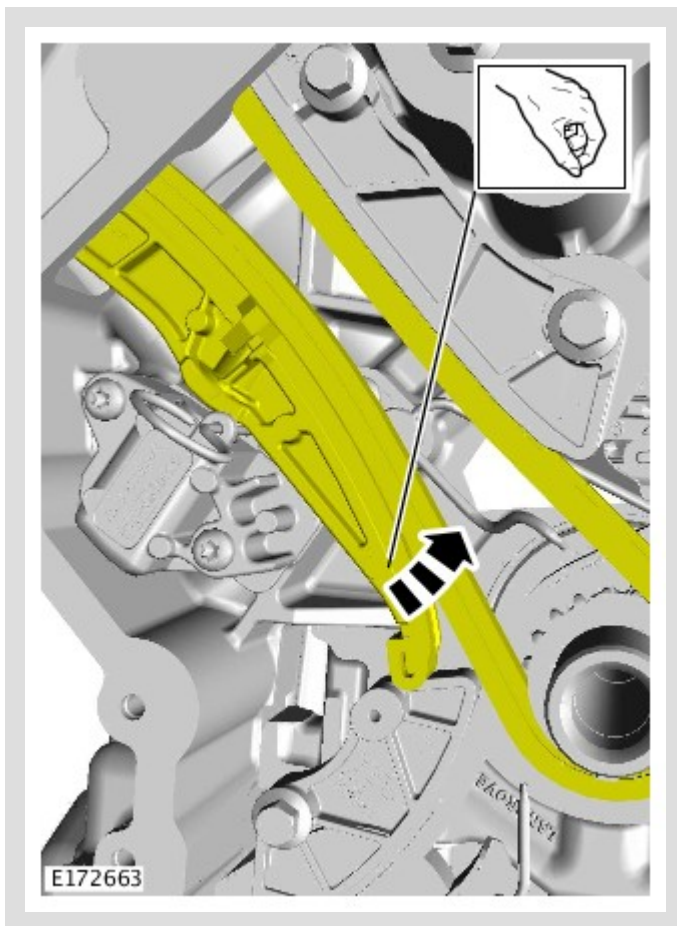

Apply and maintain tension on the component.

81.

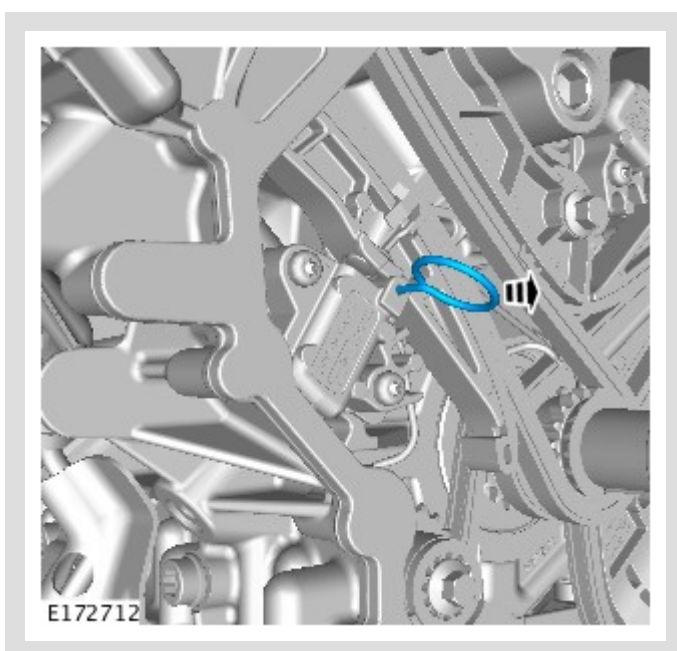

Remove the timing chain tensioner retaining pin and release the timing chain guide.

82.

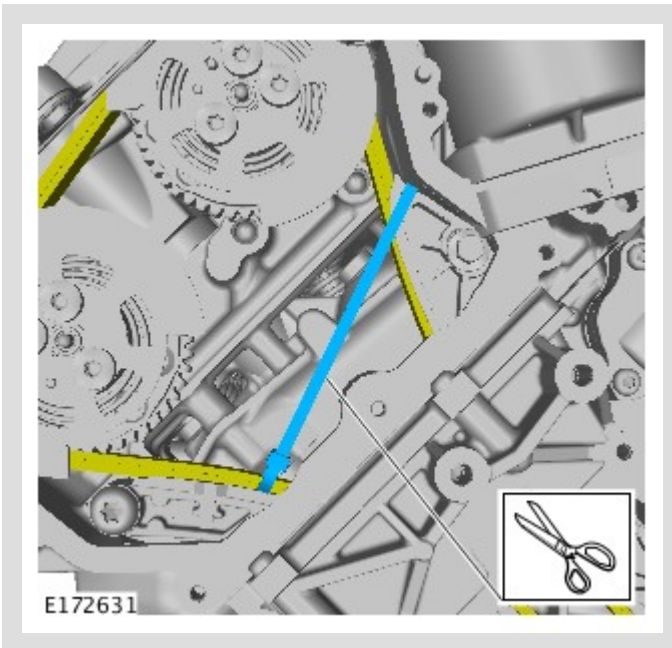

Remove and discard the tie strap.

83.

 **NOTE:**

Left hand illustration shown, Right hand is similar.

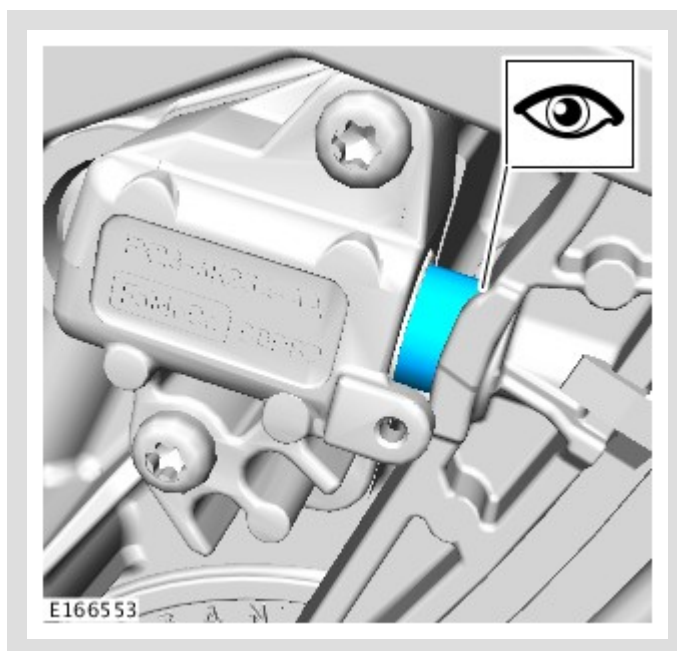

The piston should apply tension to the timing chain guide.

84.

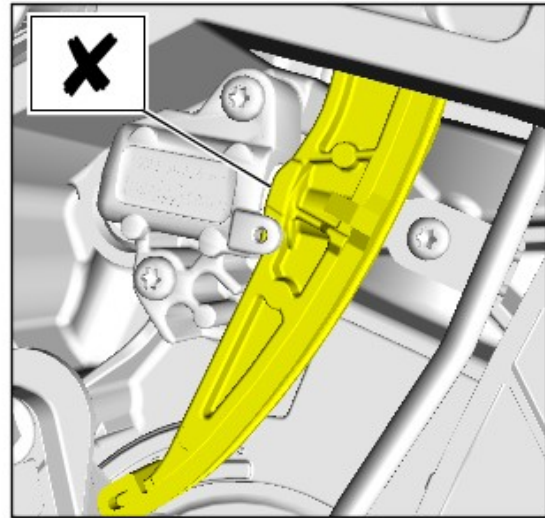
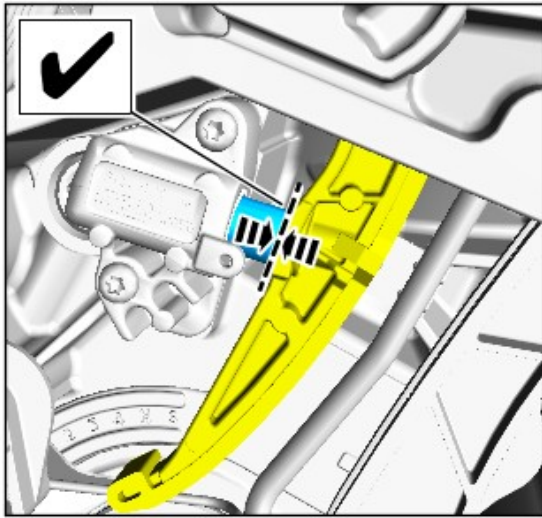

E166556

The timing chain tensioner must maintain tension on the chain guide. If the piston can be pushed back so the chain guide contacts with the body of the tensioner, the tensioner is not correct. Repeat steps 78-84.

85.

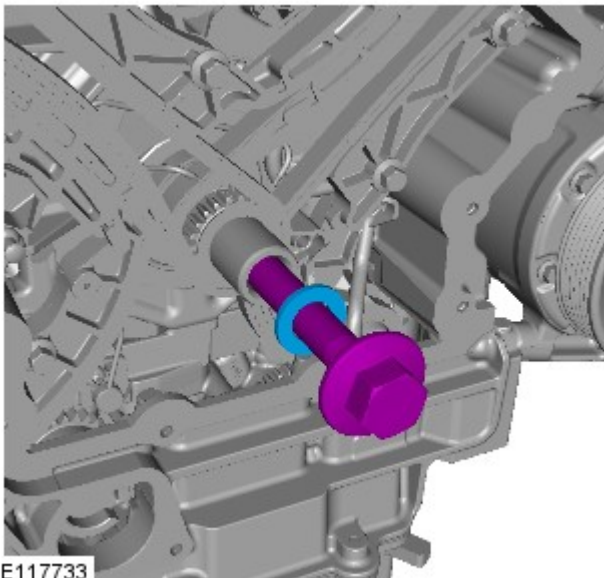

E117733

Remove the crankshaft pulley bolt.

1.

### ⚠ CAUTIONS:

- Use only a plastic scraper when removing the sealing material.
- Make sure that the mating faces are clean and free of foreign material.
- Make sure that the Land Rover approved cleaning fluid (Loctite 7063) is used to clean the mating faces.

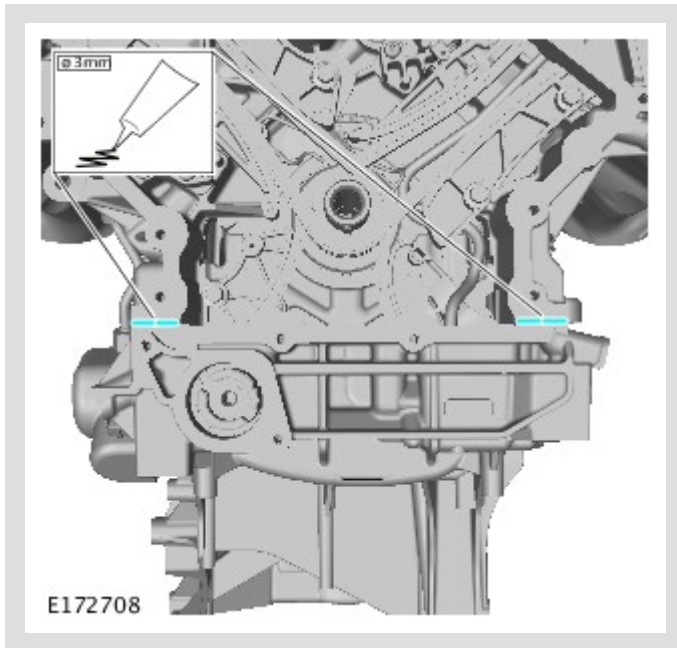

Apply RTV sealant (Loctite 5901G) to the areas shown.

2.

**⚠ CAUTION:**

Make sure that a new component is installed.

**△ NOTE:**

Tighten the retaining bolts in the indicated sequence.

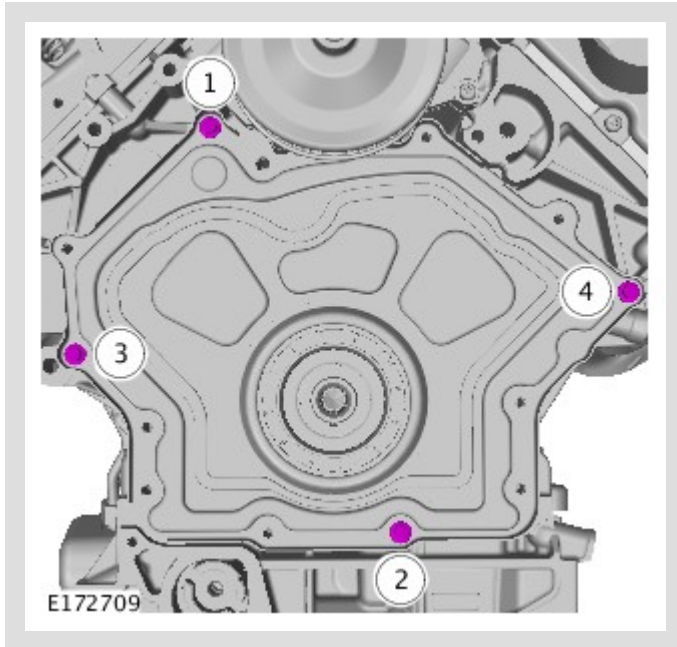

Tighten the lower timing cover bolts within 7 minutes.

Renew Part: [Lower timing cover](#) Quantity: 1.

Torque: **12 Nm**

3.

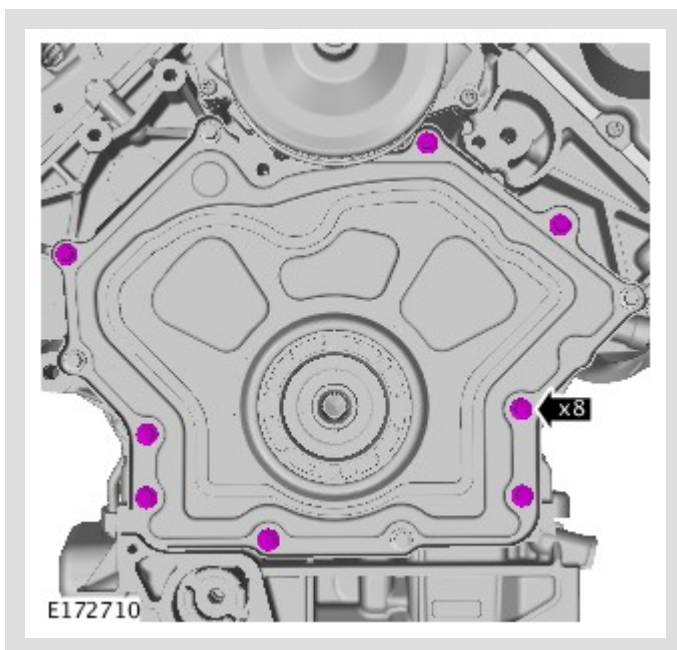

Tighten the lower timing cover bolts within 7 minutes.

Torque: **12 Nm**

4.

 **NOTE:**

Lubricate the O-ring seal with clean engine oil.

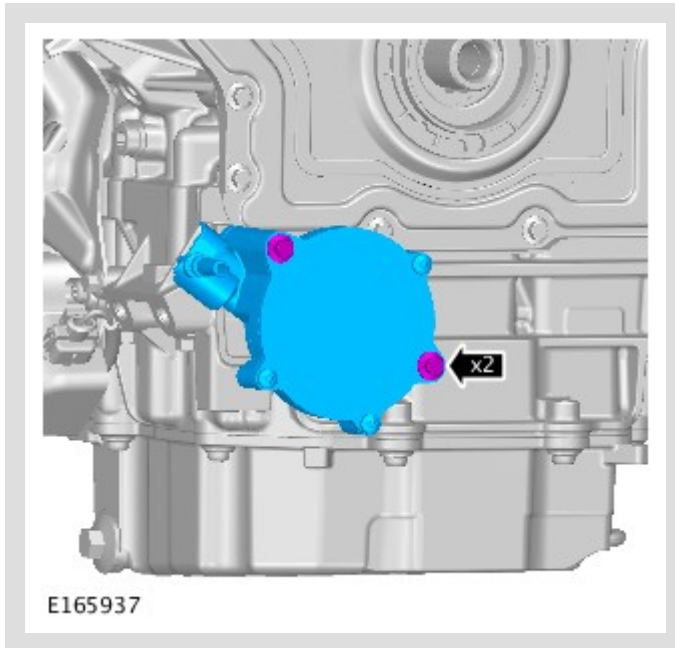

*Torque: 12 Nm*

5.

 **CAUTIONS:**

- Use only a plastic scraper when removing the sealing material.
- Make sure that the mating faces are clean and free of foreign material.
- Make sure that the Land Rover approved cleaning fluid (Loctite 7063) is used to clean the mating faces.



6.

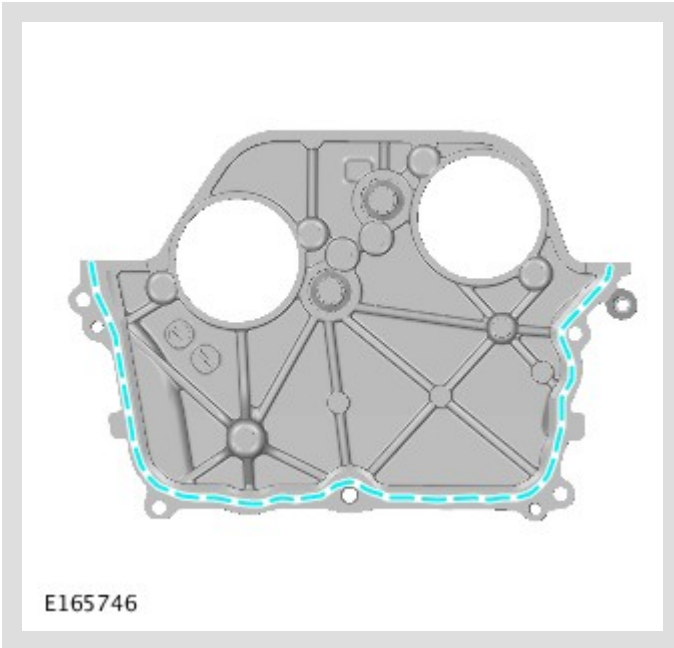

Apply RTV sealant (Loctite 5901G) to the areas shown, install the component, and tighten the bolts within 7 minutes.

7.

 **CAUTION:**

Take extra care not to damage the seal when installing the component.

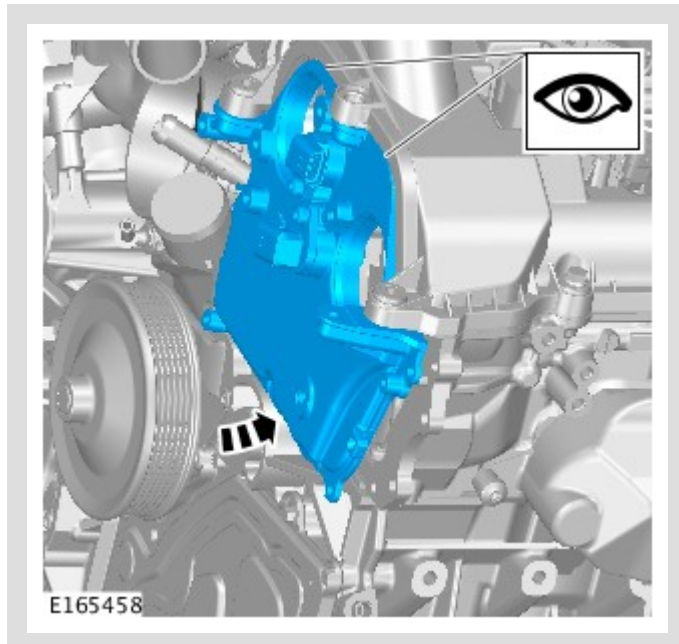

8.

 **NOTE:**

Tighten the retaining bolts in the indicated sequence.

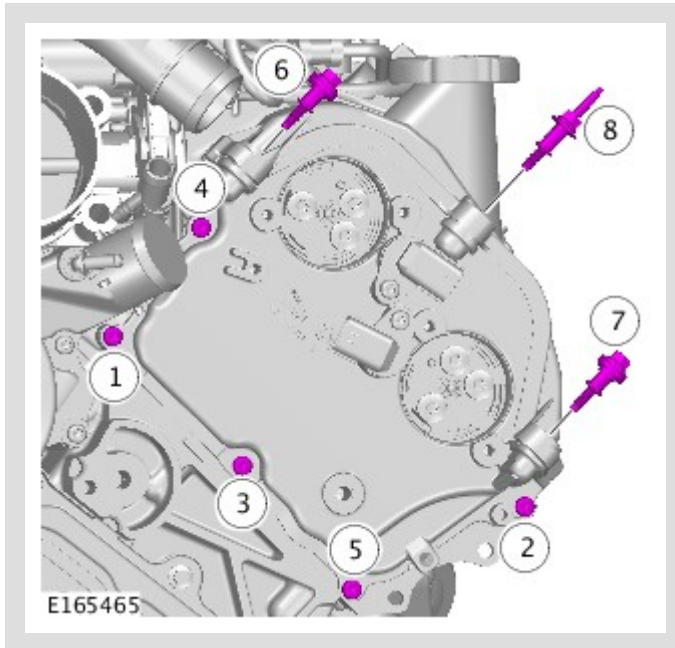

*Torque: 12 Nm*

9.

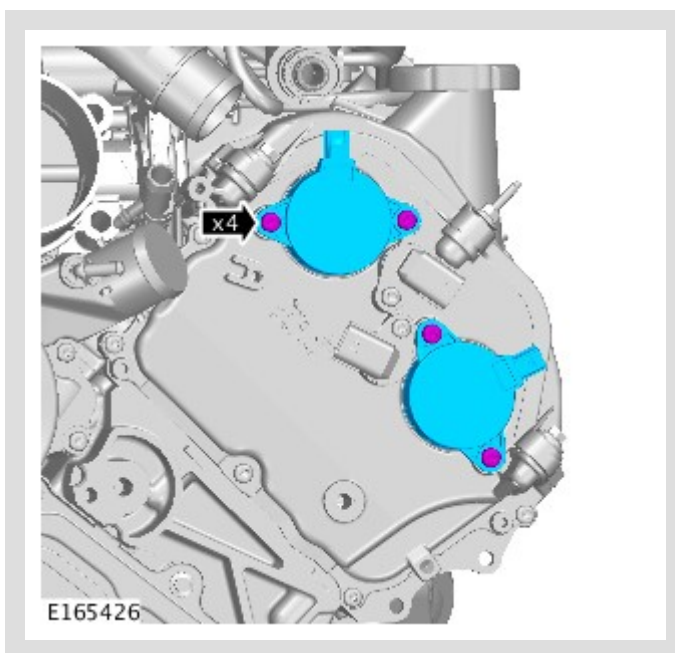

*Torque: 12 Nm*

10.

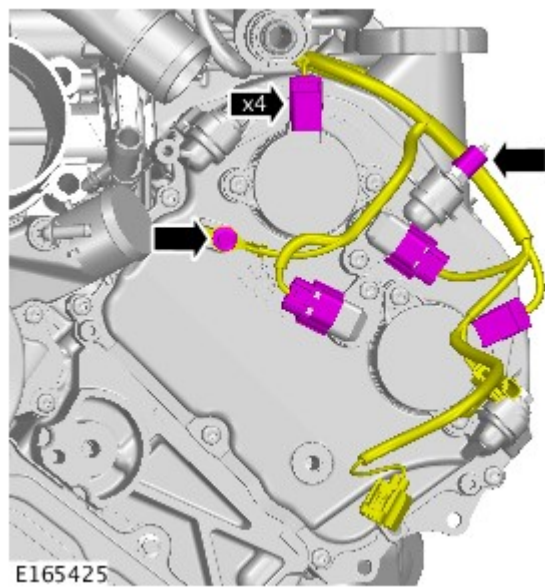

*Torque: 10 Nm*

11.

**⚠ CAUTION:**

Using a suitable tool, lock the component.

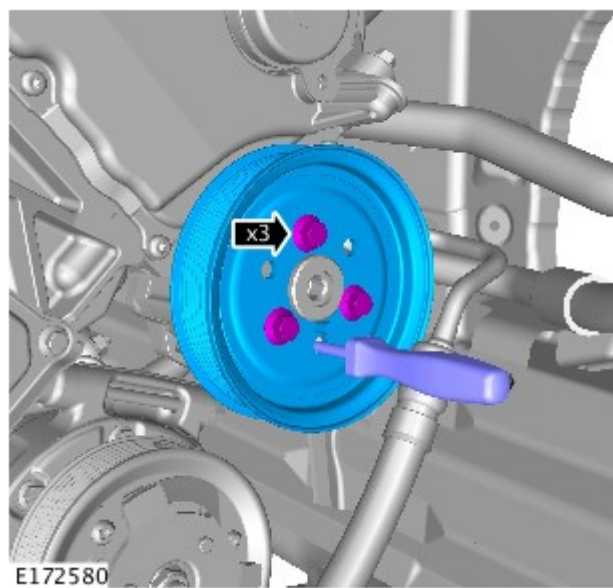

*Torque: 25 Nm*

12.

**!** CAUTIONS:

- Use only a plastic scraper when removing the sealing material.
- Make sure that the mating faces are clean and free of foreign material.
- Make sure that the Land Rover approved cleaning fluid (Loctite 7063) is used to clean the mating faces.

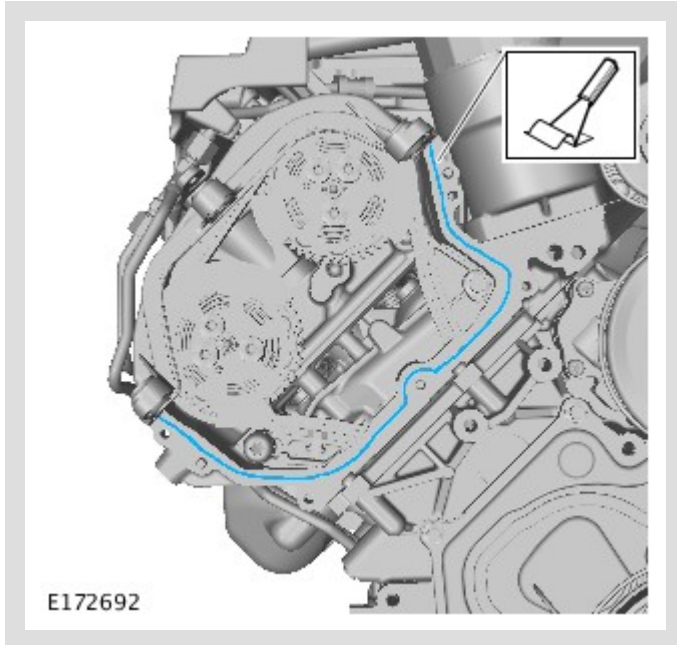

13.

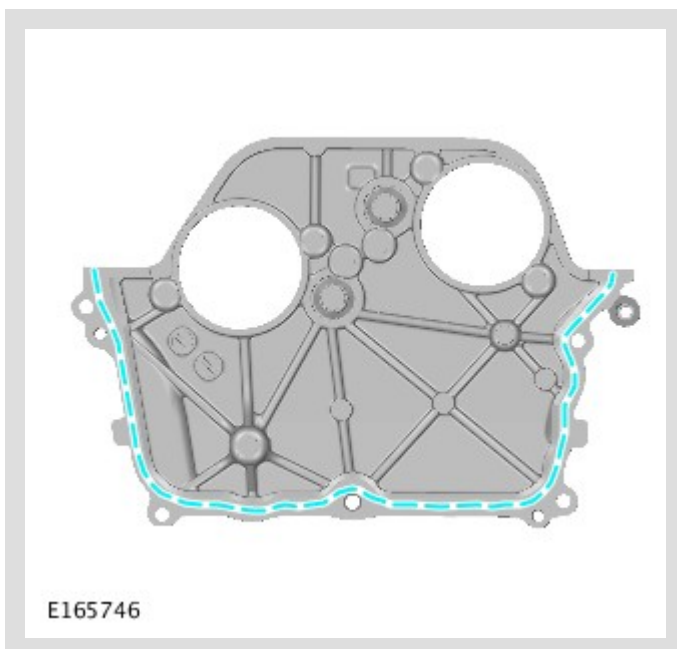

Apply RTV sealant (Loctite 5901G) to the areas shown, install the component, and tighten the bolts within 7 minutes.

14.

**⚠ CAUTION:**

Take extra care not to damage the seal when installing the component.

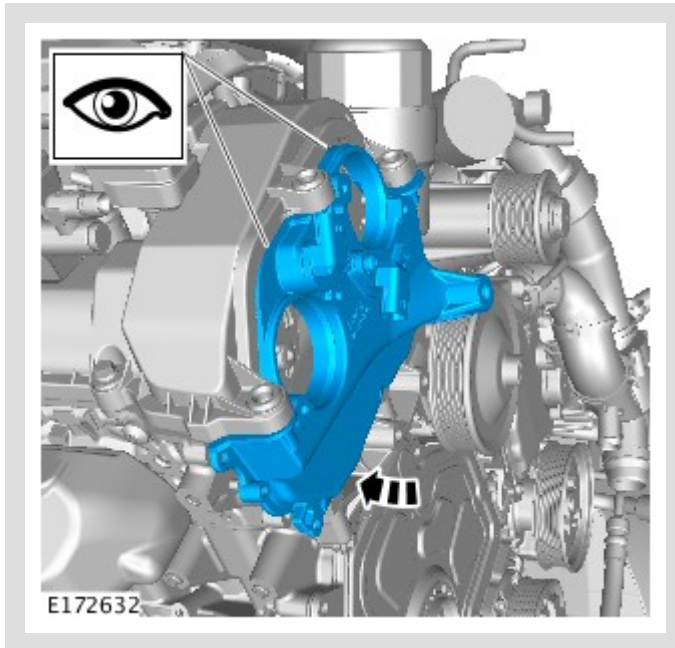

15.

**△ NOTE:**

Tighten the retaining bolts in the indicated sequence.

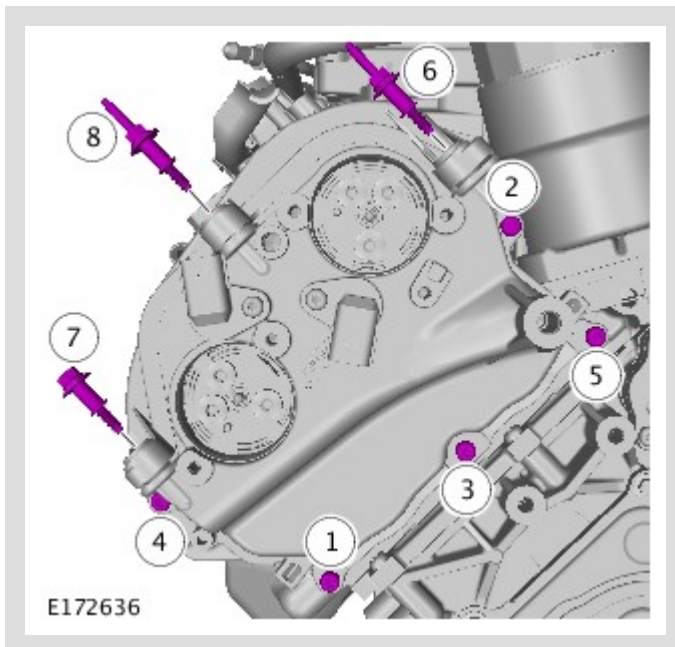

13

**Torque: 12 Nm**

16.

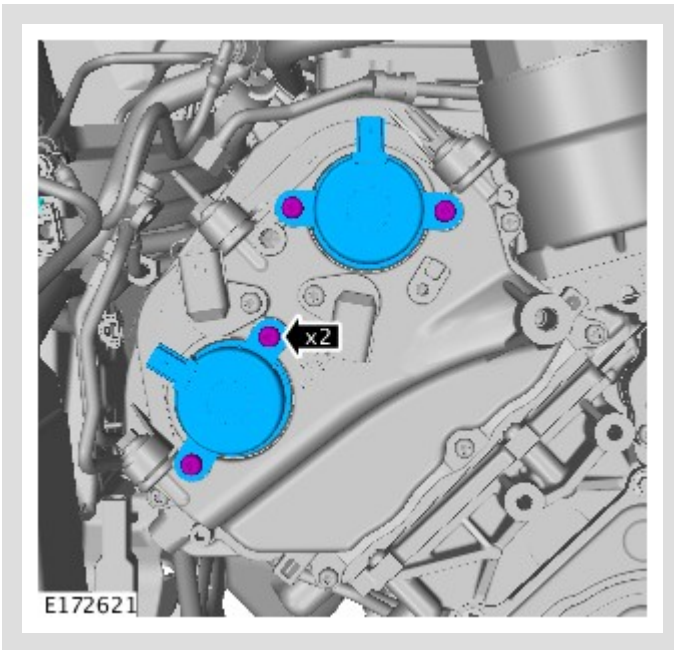

*Torque: 12 Nm*

17.

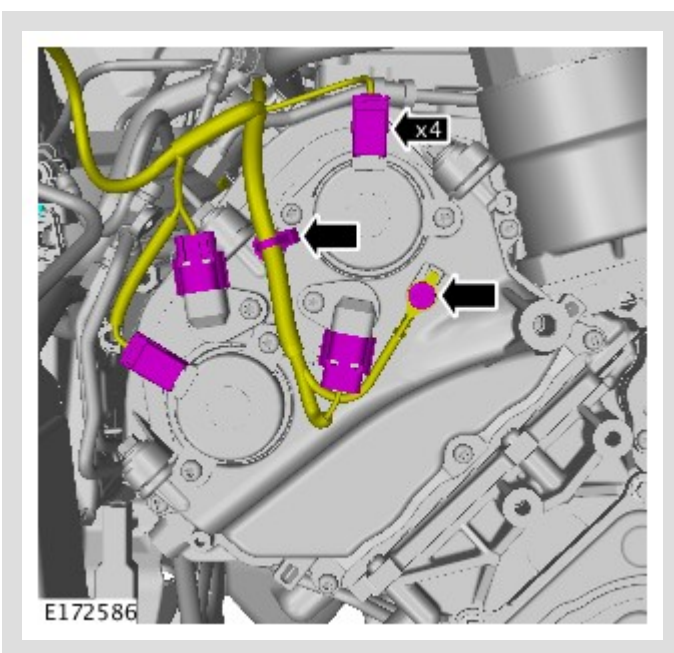

*Torque: 10 Nm*

18.

 NOTE:

Some variation in the illustrations may occur, but the essential information is always correct.

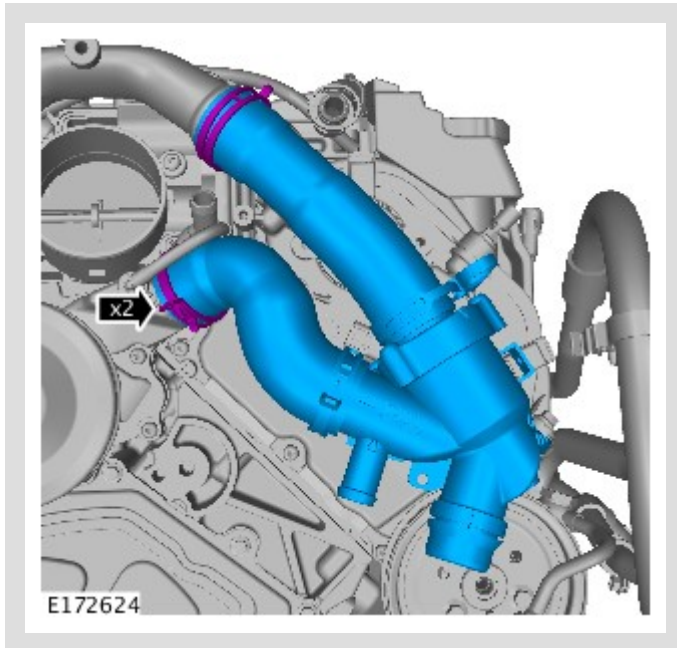

19.

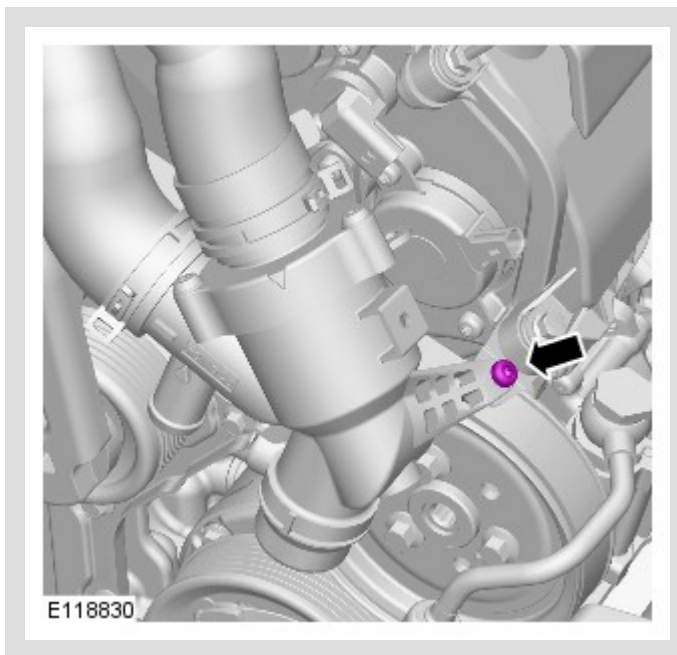

*Torque: 10 Nm*

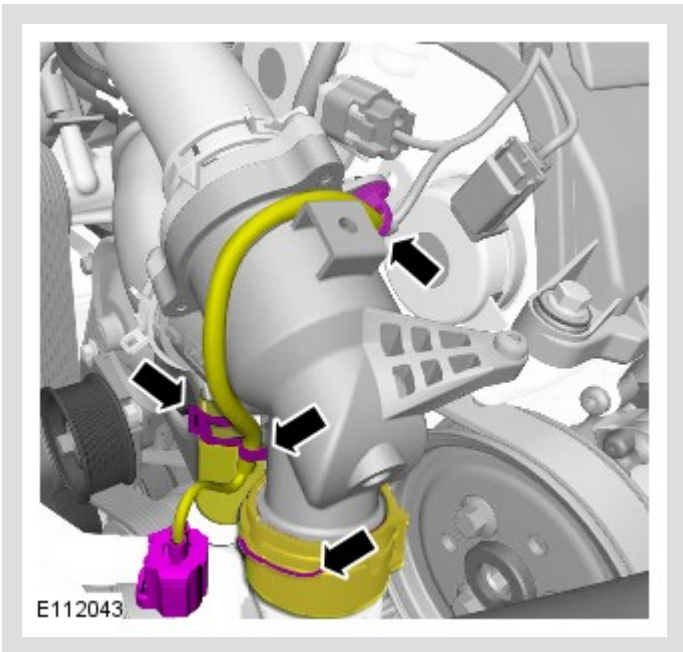

21.

**!** CAUTIONS:

- Lubricate only the union threads with clean engine oil.
- Only tighten the bolts finger-tight at this stage.

**△** NOTE:

Remove and discard the blanking caps.

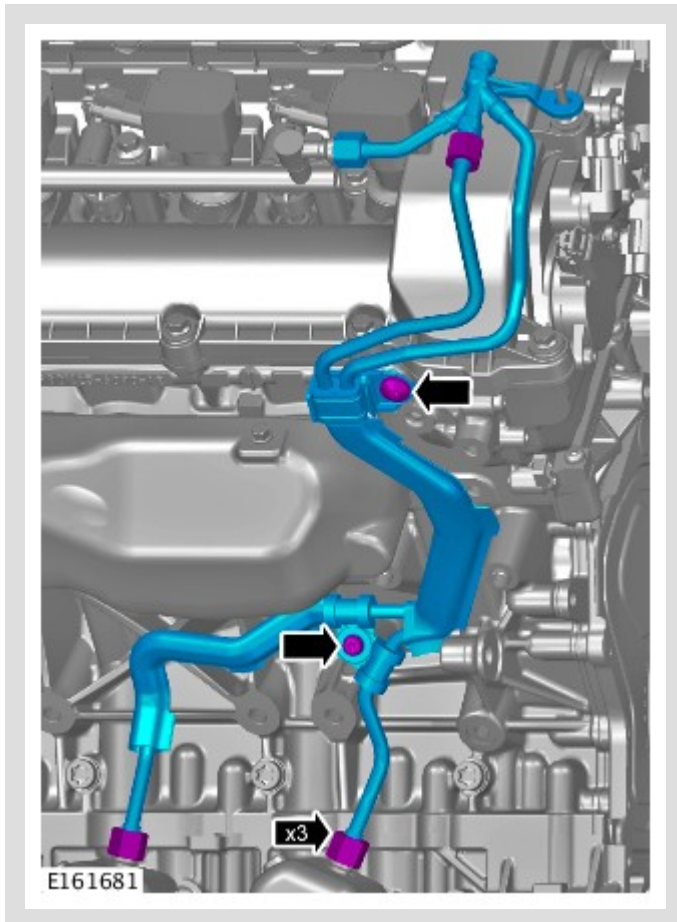

Renew Part: *Fuel rail supply pipe(s)* Quantity: 1.

22.

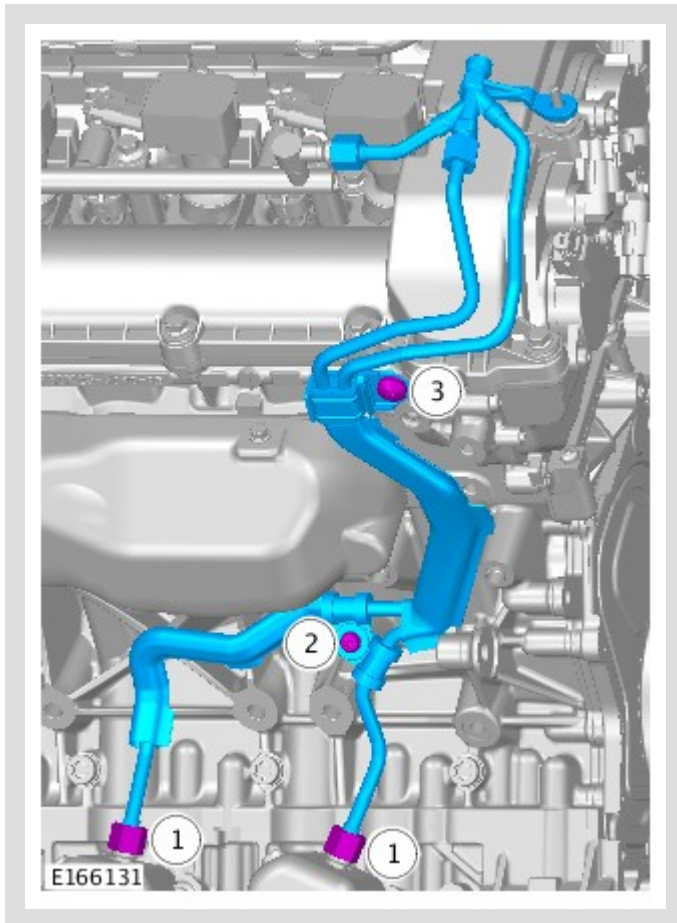

*Torque*

Unions (1) : **21 Nm**

M6 (2) : **11 Nm**

M8 (3) : **25 Nm**

23.

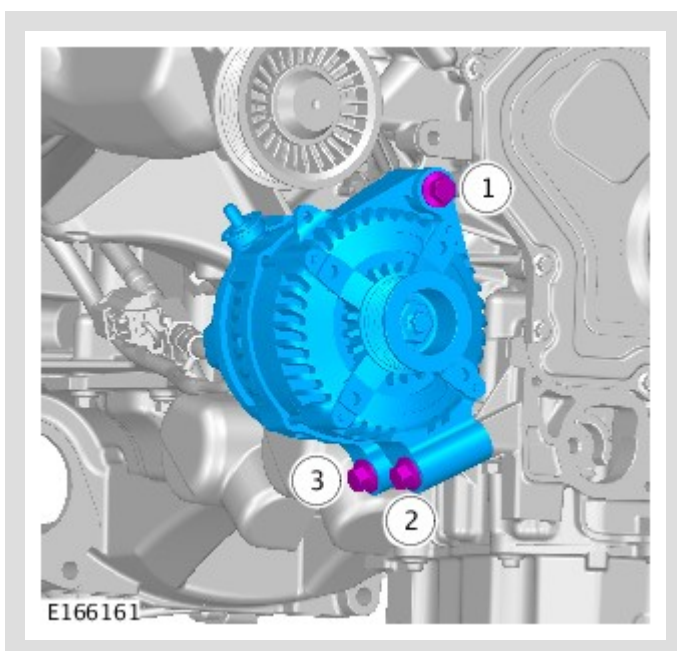

*Torque:* **48 Nm**

24.

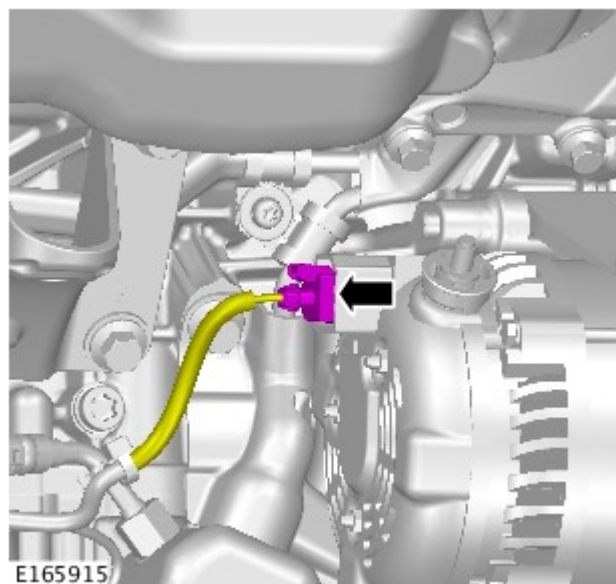

25.

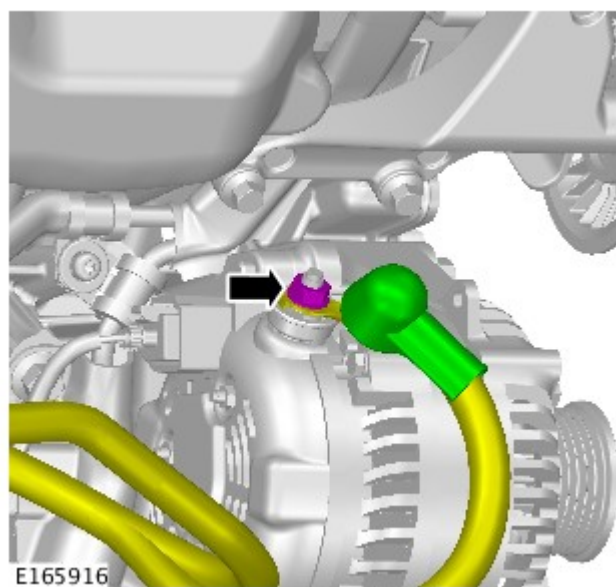

*Torque: 12 Nm*

26.

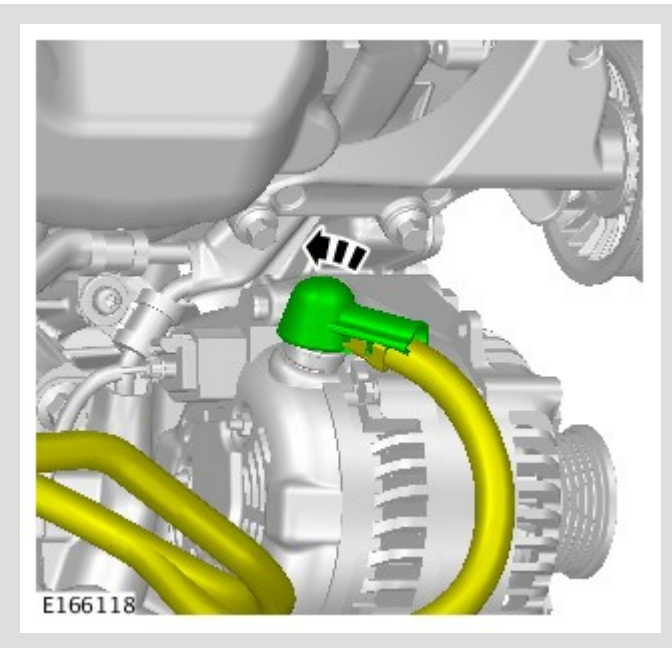

27.

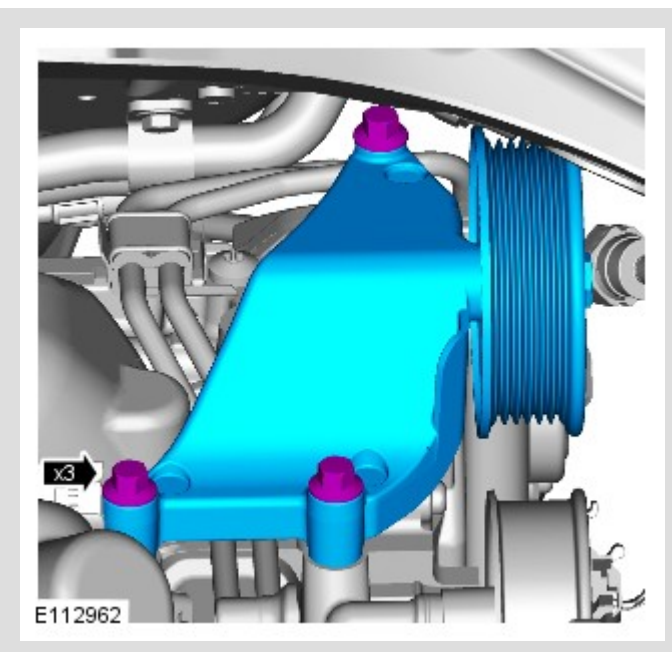

*Torque: 25 Nm*

28.

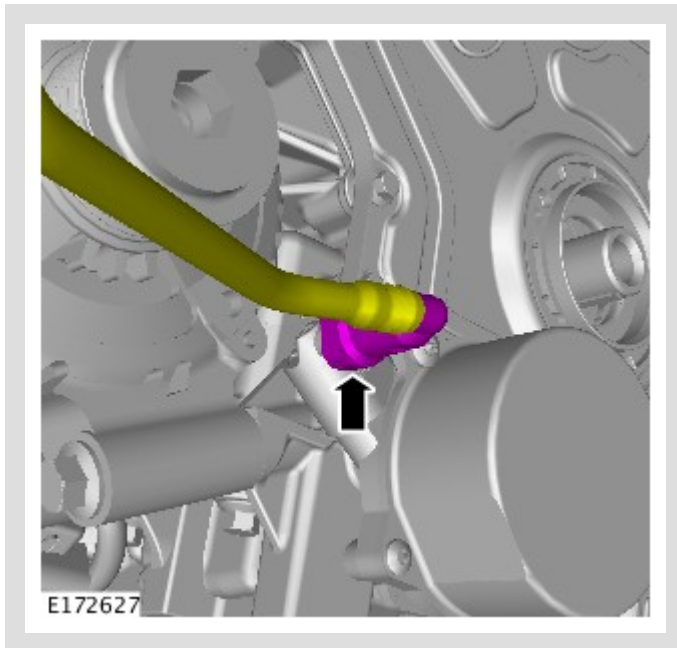

29. Refer to: [Engine Undershield](#) (501-02 Front End Body Panels, Removal and Installation).

30.



**WARNING:**

The wheel and tire assembly will be heavy.



**CAUTION:**

Apply a small amount of grease to the hub and wheel mating surfaces before installation. Make sure the grease does not come into contact with the vehicles braking components and the wheel stud threads. Failure to follow these instructions may result in personal injury.

Install the RH front wheel and tire.

*Torque:* **125 Nm**

31.

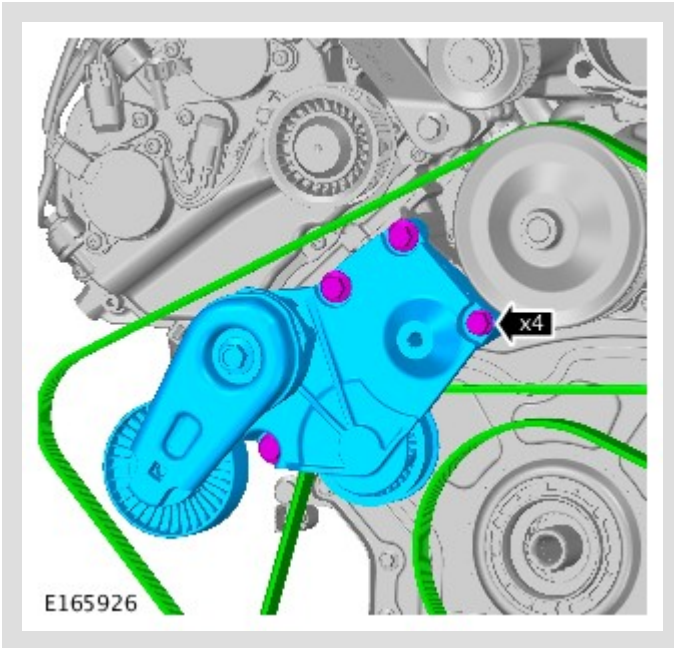

Install the FEAD belt.

*Torque: 25 Nm*

32.

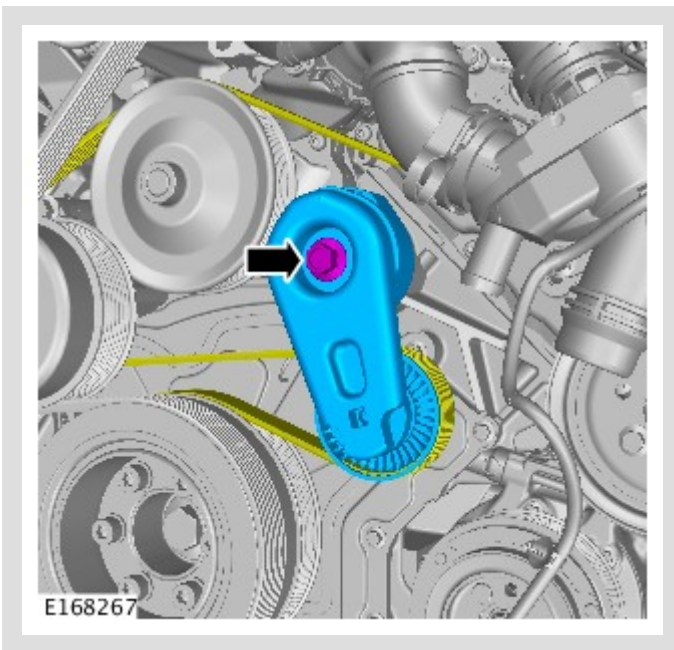

*Torque: 48 Nm*

33.

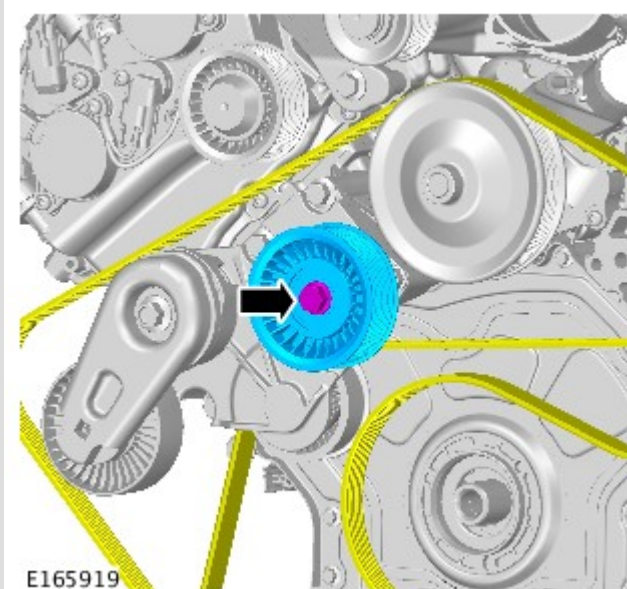

Torque: **48 Nm**

34. Refer to: [Crankshaft Pulley](#) (303-01B Engine - V8 N/A 5.0L Petrol, Removal and Installation).

35.

 **NOTE:**

Remove and discard the blanking caps.

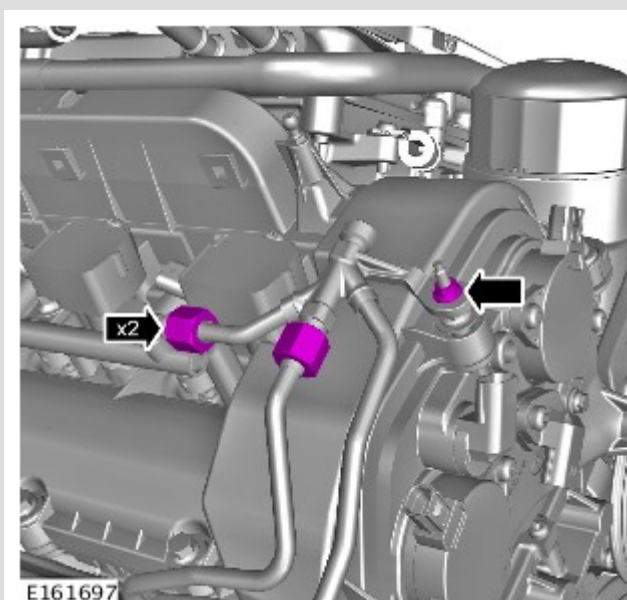

Torque

Unions : **21 Nm**

M5 nut : **6 Nm**

36.

**!** CAUTIONS:

- Remove and discard the blanking caps.
- Only tighten the bolts finger-tight at this stage.
- This fuel pipe can be re-used, inspect for signs of damage. Renew if necessary.

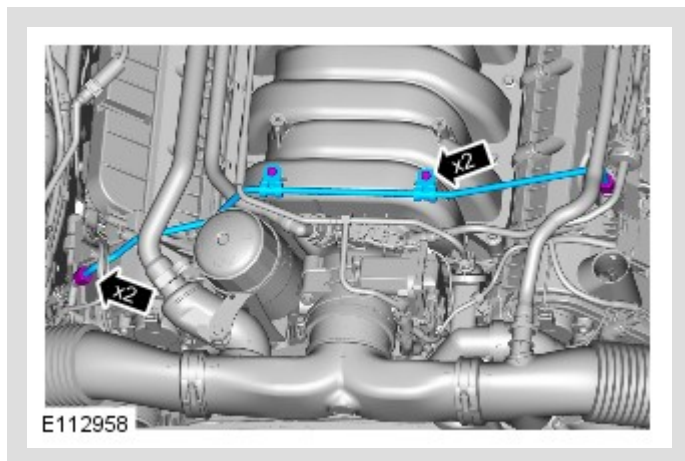

37.

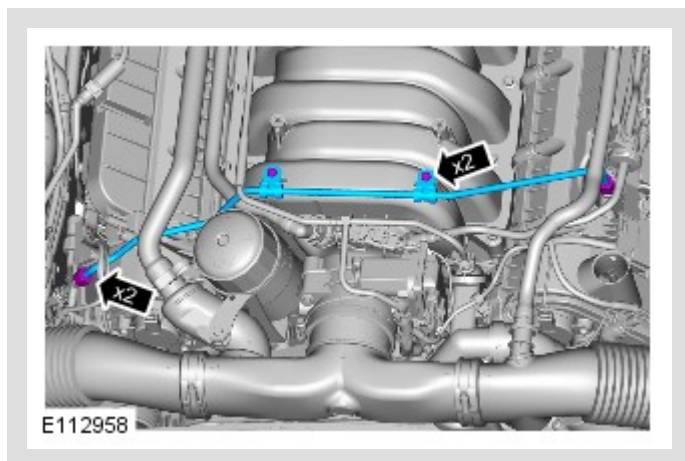

*Torque*

Unions : **21 Nm**

Bolts : **8 Nm**

38.

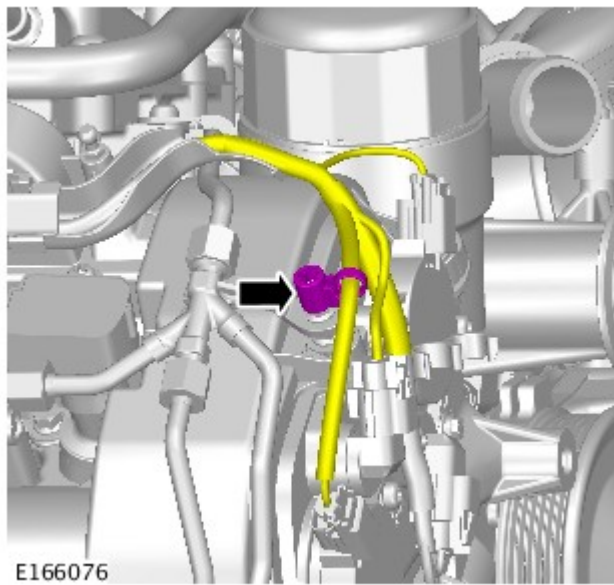

E166076

39.

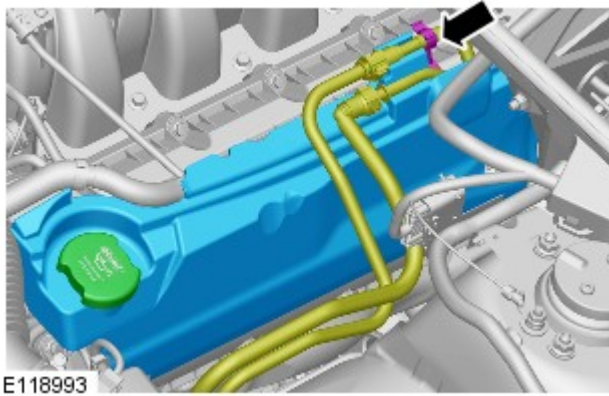

E118993

40.

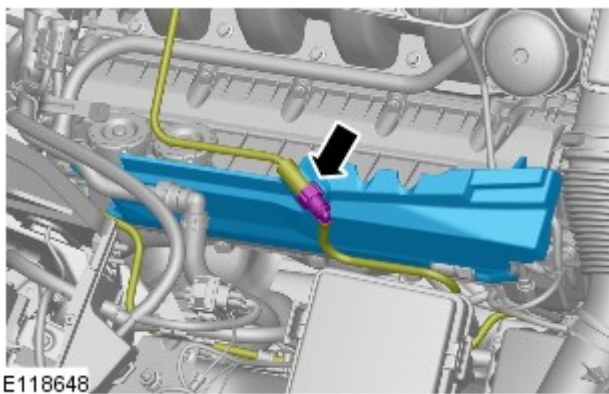

E118648

41.

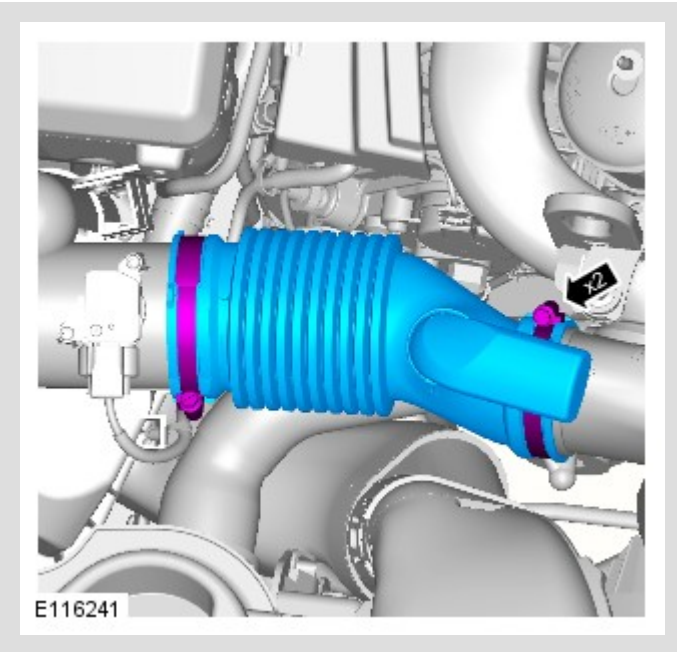

42. Refer to: [Air Cleaner Outlet Pipe T-Connector - V8 N/A 5.0L Petrol](#) (303-12B Intake Air Distribution and Filtering - V8 N/A 5.0L Petrol/V8 S/C 5.0L Petrol, Removal and Installation).

43. Refer to: [Cooling System Partial Draining and Vacuum Filling](#) (303-03A Engine Cooling - V8 N/A 5.0L Petrol /V8 S/C 5.0L Petrol, General Procedures).

44. Connect the battery ground cable.  
Refer to: [Startup Battery Disconnect and Connect](#) (414-01 Battery, Mounting and Cables, General Procedures).