

10ml Oil - Crank 10Sec Each Cylinder

 B = wet cylinder compression test.

A = Dry
B = Wet

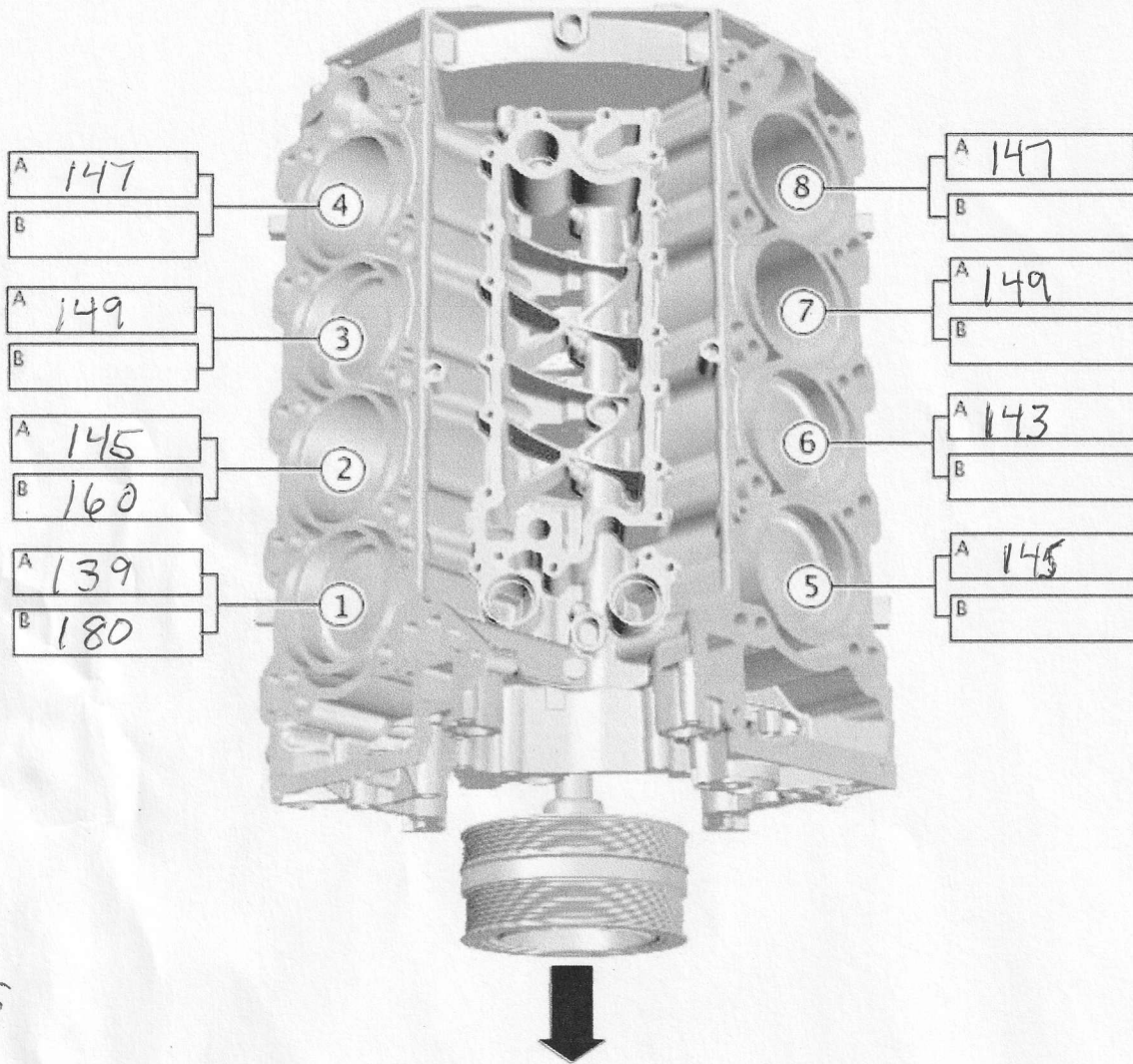

Plugs

E164747

Factory 3.7 Kohm
Replace 4.1 Kohm

12.  NOTE: Remove and discard all blanking caps.

To install, reverse the removal procedure.

13. The minimum cylinder compression reading recorded must be within 10% of the maximum cylinder compression reading recorded. If the difference across the cylinders is higher than 10% please contact dealer technical support (DTS) for further assistance.

14. Using Land Rover approved diagnostic equipment, read and clear any diagnostic trouble codes (DTCs).