

## Engine - V8 S/C 5.0L Petrol - Valve Cover LH

Removal and Installation

### Special Tool(s)

 <p>E116982</p>	<p>303-1446 Valve Cover Alignment Tool</p>
--	--

### Removal



NOTE: Removal steps in this procedure may contain installation details.

1. Refer to: [Battery Disconnect and Connect](#) (414-01 Battery, Mounting and Cables, General Procedures).
2. Refer to: [Supercharger](#) (303-12D Intake Air Distribution and Filtering - V8 S/C 5.0L Petrol, Removal and Installation).
3. Refer to: [Secondary Bulkhead Panel LH - TDV6 3.0L Diesel /V8 5.0L Petrol/V8 S/C 5.0L Petrol](#) (501-02 Front End Body Panels, Removal and Installation).
4. Refer to: [Air Cleaner Outlet Pipe LH](#) (303-12D Intake Air Distribution and Filtering - V8 S/C 5.0L Petrol, Removal and Installation).
5. Refer to: [Fuel Rail LH](#) (303-04E Fuel Charging and Controls - V8 S/C 5.0L Petrol, Removal and Installation).

6. Torque: 10 Nm

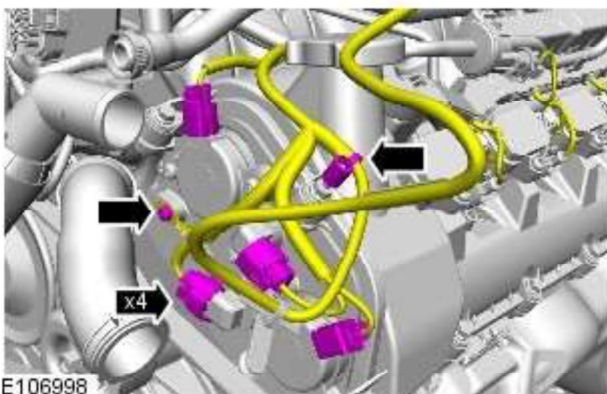

7.

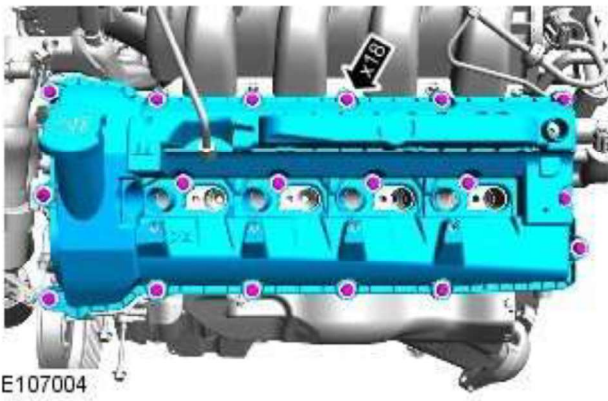

## Installation

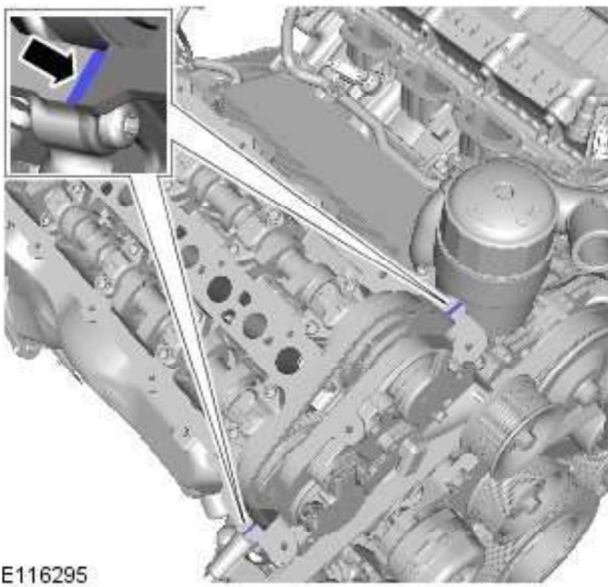

### 1. CAUTIONS:



Use only a plastic scraper when removing the sealing material.



Use lint free cloth.



Make sure that the mating faces are clean and free of corrosion and foreign material.



Installation of the valve cover and tightening must be carried out within 7 minutes of applying the sealant.

### NOTES:



Some variation in the illustrations may occur, but the essential information is always correct.



Apply two beads of silicone gasket sealant (Loctite 5901) as shown on the illustration. The application of the sealant must be 1.5mm diameter 12mm long. Install the valve cover immediately after applying the sealant. The cover should be fitted directly to the head without smearing the sealant or the seals.

To install, reverse the removal procedure.

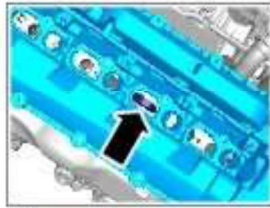

- NOTE: Some variation in the illustrations may occur, but the essential information is always correct.

Special Tool(s): [303-1446](#)

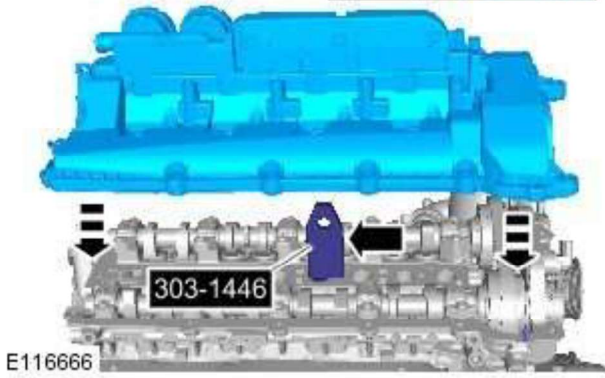

E116666

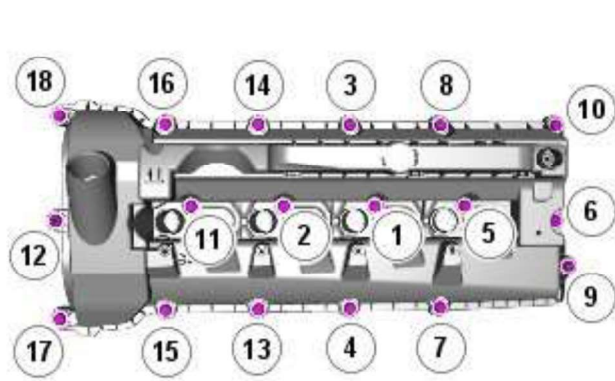

E107006

-  NOTE: Tighten the bolts in the indicated sequence.

Torque: 13 Nm

## Engine - V8 S/C 5.0L Petrol - Valve Cover RH

Removal and Installation

### Special Tool(s)

 E116982	303-1446 Valve Cover Alignment Tool
--	--

### Removal



NOTE: Removal steps in this procedure may contain installation details.

1. Refer to: [Battery Disconnect and Connect](#) (414-01 Battery, Mounting and Cables, General Procedures).
2. Refer to: [Supercharger](#) (303-12D Intake Air Distribution and Filtering - V8 S/C 5.0L Petrol, Removal and Installation).
3. Refer to: [Secondary Bulkhead Panel RH - TDV6 3.0L Diesel /V8 5.0L Petrol/V8 S/C 5.0L Petrol](#) (501-02 Front End Body Panels, Removal and Installation).
4. Refer to: [Air Cleaner Outlet Pipe RH](#) (303-12D Intake Air Distribution and Filtering - V8 S/C 5.0L Petrol, Removal and Installation).
5. Refer to: [Fuel Rail RH](#) (303-04E Fuel Charging and Controls - V8 S/C 5.0L Petrol, Removal and Installation).

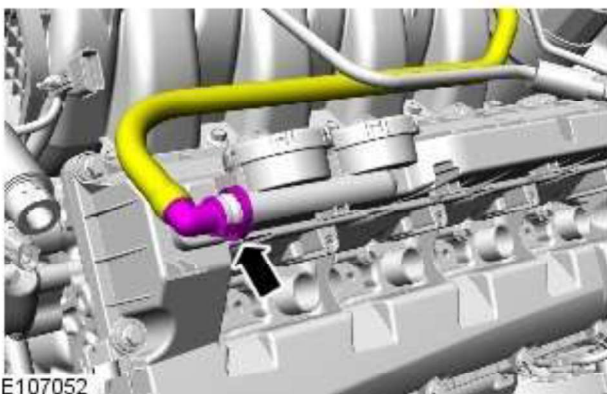

6. NOTE: Some variation in the illustrations may occur, but the essential information is always correct.

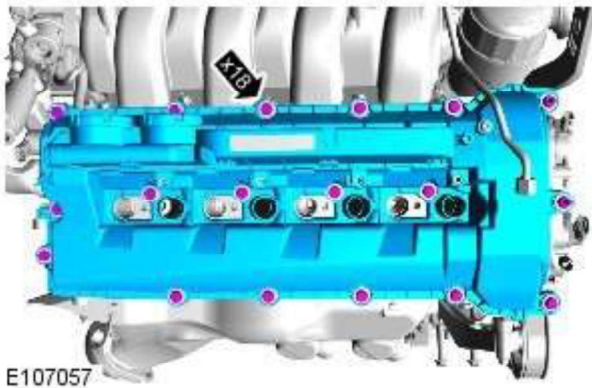

E107057

7.  NOTE: Some variation in the illustrations may occur, but the essential information is always correct.

## Installation

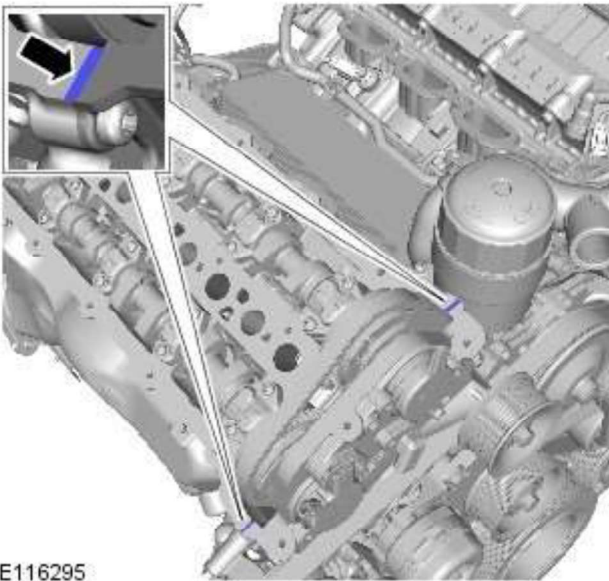

E116295

1. CAUTIONS:



Use only a plastic scraper when removing the sealing material.



Use lint free cloth.



Make sure that the mating faces are clean and free of corrosion and foreign material.



Installation of the valve cover and tightening must be carried out within 7 minutes of applying the sealant.



NOTE: Apply two beads of silicone gasket sealant (Loctite 5901) as shown on the illustration. The application of the sealant must be 1.5mm diameter 12mm long. Install the valve cover immediately after applying the sealant. The cover should be fitted directly to the head without smearing the sealant or the seals.

To install, reverse the removal procedure.

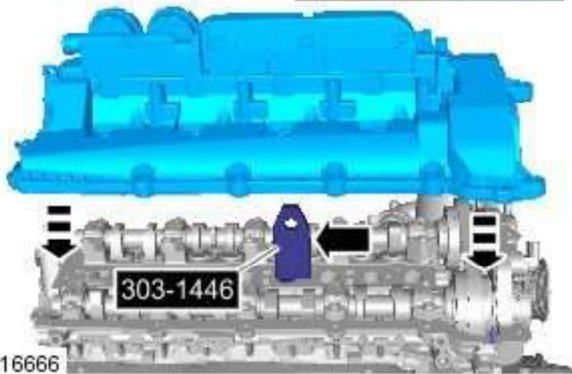

E116666

2. NOTE: Some variation in the illustrations may occur, but the essential information is always correct.

Special Tool(s): [303-1446](#)

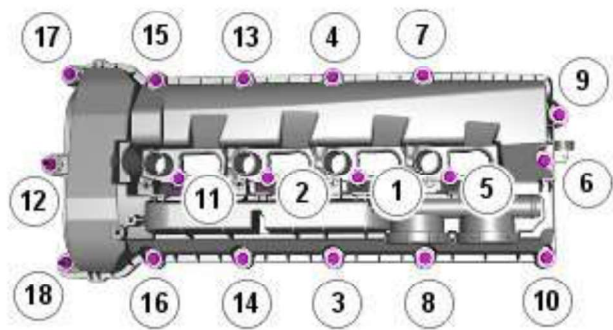

E107058

3.  NOTE: Tighten the bolts in the indicated sequence.

Torque: 13 Nm