

Description of Reverse gear power flow

The turbine shaft drives the ring gear of the single front planetary gear set and the outer plate carrier of clutch "E".

Ring gear 1 drives the planetary gears, which roll round fixed sunwheel 1. This drives planetary gear spider 1 and also outer plate carrier "A" and the inner plate carrier of clutch "B".

When clutch "B" is engaged, sunwheel 2 in the double planetary gear set is driven; it is in mesh with the long planetary gears.

The double planetary gear spider is locked to the transmission housing by brake "D". As a result, ring gear 2 (output shaft) can be driven in the opposite direction to engine rotation by way of the long planetary gears.

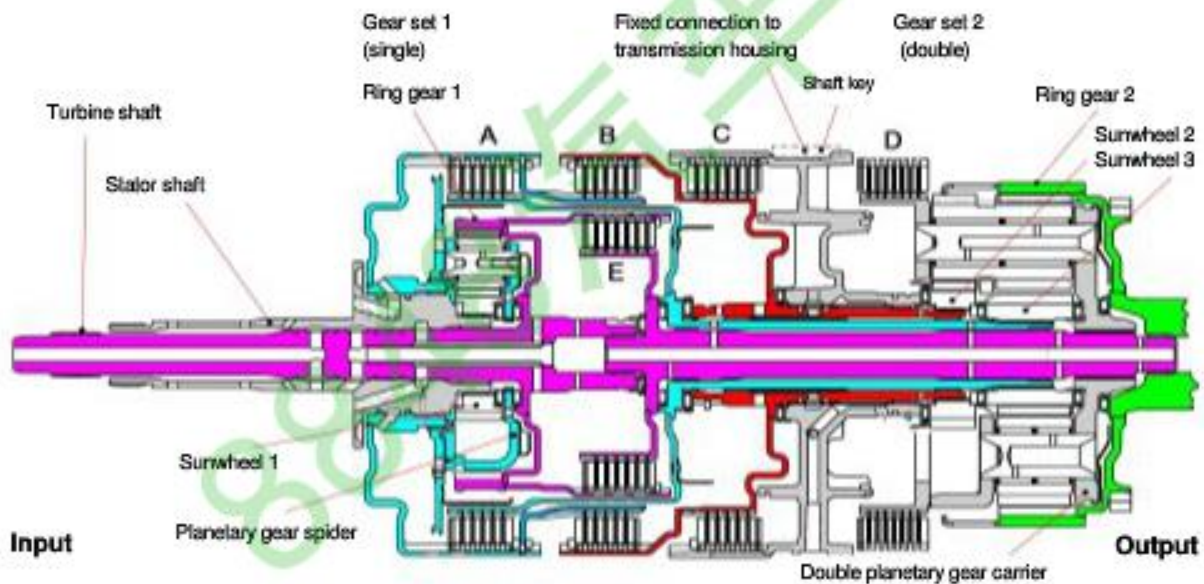

6HP26 E20 E- Schaltung

Pos / Gear	Solenoid / Regulator Valve Logic									Clutch-Logic					
	MV			P- EDS						Clutch				Brake	
	1	2	3	1	2	3	4	5	6	A	B	E	WK	C	D
P = Parken							X	-X-							●
R = R- Gang	X	X	X		X		X	-X-		●					●
N = Neutral	X	X	X				X	-X-							●
D, 1. Gang	X	X	X	X			X	-X-	-X-	●			●		●
D, 2. Gang	X	X	X	X		X		-X-	-X-	●			●	●	
D, 3. Gang			X	X	X			-X-	-X-	●	●		●		
D, 4. Gang	X		X	X			X	-X-	-X-	●		●	●		
D, 5. Gang	X		X		X		X	-X-	-X-		●	●	●		
D, 6. Gang	X		X			X	X	-X-	-X-			●	●	●	
	Schaltventil 1	Parksperr- Ventil	Parksperr- Zylinder	Kupplung A	Kupplung B	Bremse C	Bremse D / Kupplung E	System- Druck	Regelung zur Ganglogik (situationsbedingt)	Planetensteg 1. Radsatz	Sonnenrad 1 (Doppelradsatz)	Steg Doppelradsatz	situationsbedingte Regelung der Wandlüberbr.- Kupplung	Sonnenrad Nr. 1 (Doppelradsatz)	Planetensteg (Doppelradsatz)

6HP26 E20 M- Schaltung

Pos / Gear	Solenoid / Regulator Valve Logic									Clutch-Logic					
	MV			P- EDS						Clutch				Brake	
	1			1	2	3	4	5	6	A	B	E	WK	C	D
P = Parken							X	-X-							●
R = R- Gang					X		X	-X-		●					●
N = Neutral							X	-X-							●
D, 1. Gang				X			X	-X-	-X-	●			●		●
D, 2. Gang				X		X		-X-	-X-	●			●	●	
D, 3. Gang				X	X			-X-	-X-	●	●		●		
D, 4. Gang	X			X			X	-X-	-X-	●		●	●		
D, 5. Gang	X				X		X	-X-	-X-		●	●	●		
D, 6. Gang	X					X	X	-X-	-X-			●	●	●	
	Schaltventil 1			Kupplung A	Kupplung B	Bremse C	Bremse D / Kupplung E	System- Druck	Regelung zur Ganglogik (situationsbedingt)	Planetensteg 1. Radsatz	Sonnenrad 1 (Doppelradsatz)	Steg Doppelradsatz	situationsbedingte Regelung der Wandlerüberbr.-Kupplung	Sonnenrad Nr. 1 (Doppelradsatz)	Planetensteg (Doppelradsatz)

Hydraulic circuit diagram (E shift)

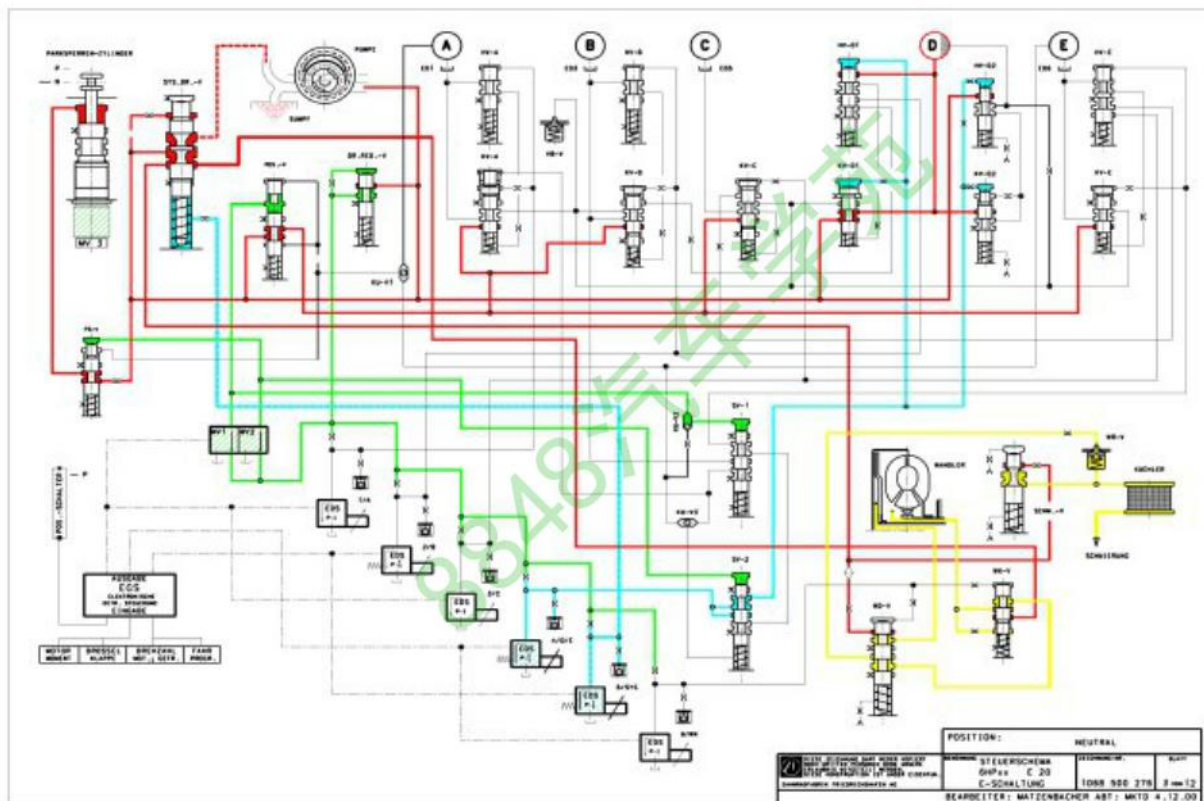

Hydraulic circuit diagram (M shift)

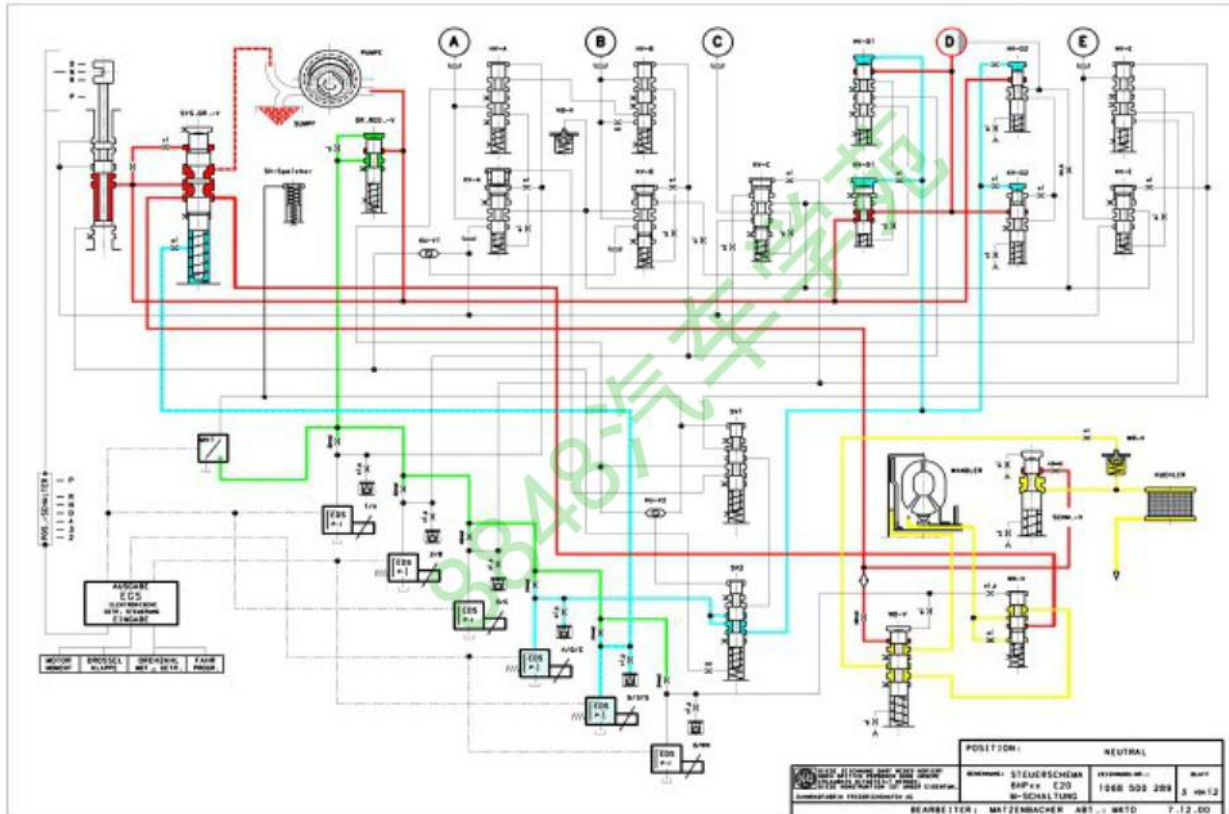

Mechatronic module

Hydraulic and electronic control units

General:

The Mechatronic module is a combination of hydraulic and electronic control units. Both these modules are installed in the transmission, in the oil pan area.

This technical principle has the following advantages:

- minimum tolerances
- better coordination of gear shifts
- increased refinement
- optimised shift quality
- good reliability, since the number of plug connections and interfaces is reduced

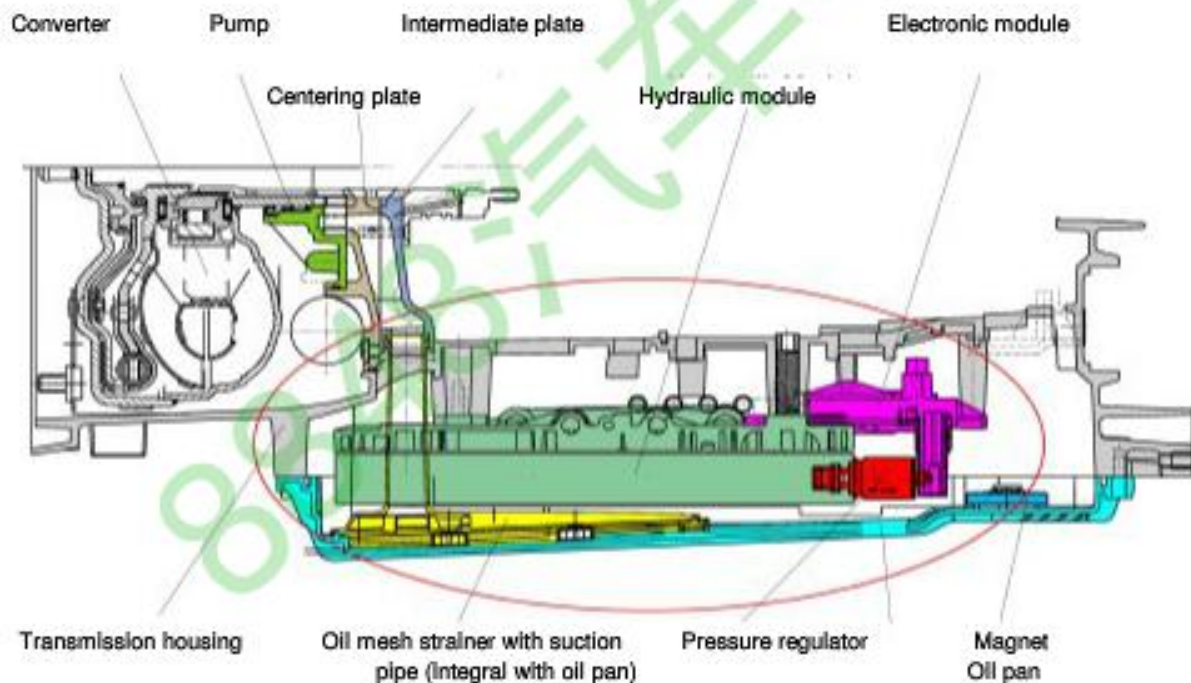

When working on the Mechatronik, for example during a repair, suitable safety precautions must be taken, particularly against ESD.

Please refer to Standard DIN EN 100015 ESD manual issued by the Electronics Committee of the German VDE / VDI Micro-electronics Society (GME).

Here are a few extracts of particular relevance:

The term ESD stands for **E**lectro**s**tatic **D**ischarge.

The human body, if electrically charged but not properly earthed (grounded), moves in an electrostatic 'cloud' and therefore endangers electronic components.

It is therefore essential to wear electrically conductive footwear and a closed protective outer garment.

Everyone must take precautions to avoid damage from electrostatic discharge:

- when incoming goods are received
- in the incoming goods test area
- in production or repair shops and also when visiting the parts store, even for a short time
- in the despatch area
- in the transport or shipping area

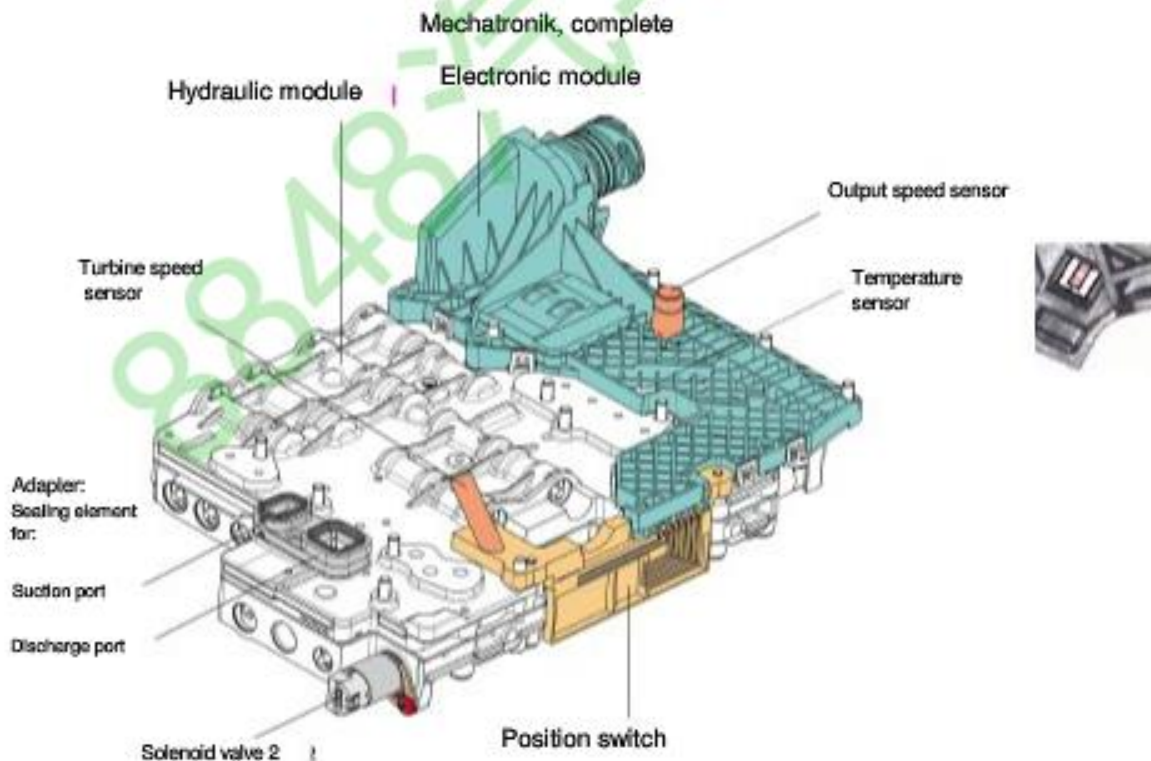

What personal precautions must be taken?

- Always note and comply with the personal protective measures:
 - In zones exposed to the risk of electrostatic discharge, always wear the correct protective coat and electrically conductive shoes
 - When working seated in a risk area, always wear an earthed (grounded) wrist band
 - Do not touch any open equipment or components without sufficient potential equalisation
- In electrostatic discharge risk zones, use only permitted means of transportation and packing materials:
 - transport crates
 - component packs
 - stores and racks
 - transport trolleys and other vehicles
- Only approved working equipment should be used:
 - earthed (grounded) soldering irons
 - earthed (grounded) solder removal tools
 - permitted auxiliary devices and tools
- Keep all insulating synthetic materials away from the work area, in particular:
 - polyethylene bags
 - polystyrene elements
 - Cellophane film
 - PVC bags, film or sleeves

Detailed instructions are given in Siemens production directive F12F1542 and in process description 051 "Manufacturing instructions for the avoidance of electrostatic discharge".

Take great care wherever you see this sign:



It is displayed near components or assemblies that are sensitive to electrostatic discharge.

Electrostatic discharge protective zones

There are various forms of electrostatic discharge protective zone:

Stationary

- Individual work station
- Workbench, desk
- Store, factory building, office
- Individual cupboards or shelves
- Service
- After-sales service

In addition to the protection afforded by electrostatic discharge protection zones, personal safety must also be guaranteed. Comply with industrial accident precautions, particularly DIN VDE 0104.

Equipment in electrostatic discharge protection zones

All areas at which work is done on electronic components and equipment should be protected against electrostatic discharge. Try to incorporate them all into a single large protection zone.

Minimum equipment, for example when a conventional work area is converted:

- Personnel earthed (grounded) with wrist band
- Table top material or mat connected to potential equalisation
- Protective packs to prevent electrostatic discharge
- The following must be electrically conductive:
 - Table top material
 - Working clothing
 - Transportation systems and storage boxes or bins

Optimum equipment, i.e. when setting up new work stations protected against electrostatic discharge:

- Personnel earthed (grounded) with wrist band (1)
- Work tables, benches and shelves connected to potential equalisation (2)
- Protective packs to prevent electrostatic discharge (3)
- Signs identifying an electrostatic discharge protection zone (4)
- Tester for personnel earthing (grounding) by means of wrist band (5)
- Tester for personnel earthing (grounding) through shoes (6)
- The following must be electrically conductive:
 - Table or bench top (7)
 - Working clothing (8)
 - Transportation systems and storage boxes or bins (9)
 - Flooring material (10)
 - Chairs (11)
 - Shoes or foot earthing (grounding) straps (12)
 - Gloves or mittens, as necessary (13)
 - Shelves (14)
 - Tools (15)

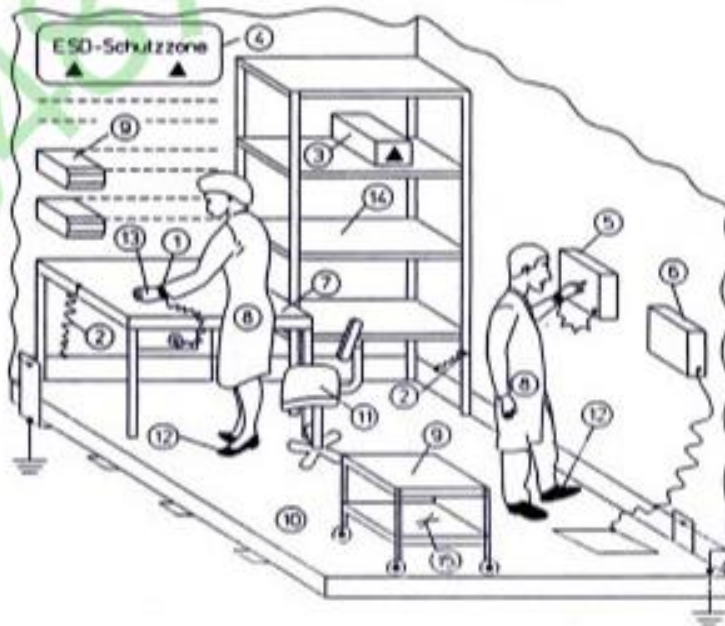

Identification of components and assemblies exposed to electrostatic discharge risk

Assemblies containing components exposed to electrostatic discharge risk must be marked with a warning symbol as a reminder that they need special handling.

Self-adhesive labels should not be attached directly to electrostatic discharge risk components, since this could increase the risk of electrostatic discharge occurring.

In such cases, the warning must be attached to the packaging material.

Identification mark

ELECTROSTATIC DISCHARGE
RISK



Identification of protection zones

Electrostatic discharge protection zones must be indicated by suitable signs (see illustration).

The sign must be attached where it is easily visible. Its minimum size must be 300 mm x 150 mm. The background colour is yellow, with black artwork.

Identification sign

Translation:
WARNING:
ELECTROSTATIC DISCHARGE
RISK ZONE
NOTE HANDLING
INSTRUCTIONS FOR
COMPONENTS EXPOSED TO
ELECTROSTATIC DISCHARGE
RISK



ESD earthing (grounding) equipment

All ESD earthing (grounding) devices installed in electrostatic discharge protection zones must be marked to identify them, using suitable symbols that call for suitable protective measures to be taken. The markings must make the intended purpose clear, but any additional information that is provided must not distract attention from the basic warning.

Specimen signs for earthing (grounding) points

Translation:

EARTHING (GROUNDING) CONTACT POINT



Packs and transportation containers

Packs and containers used for components subject to electrostatic discharge risk must carry a suitable warning notice.

In addition, transportation packs that, for instance, leave a production zone, must contain a warning slip calling for the necessary special handling procedures.

Warning slip to accompany items exposed to electrostatic discharge risk

Translation:
WARNING
COMPLY WITH
PRECAUTIONS FOR
HANDLING ELECTRO-
STATIC RISK COM-
PONENTS



Documentation

All documentation needed for the purchasing, specification, design or supply of electrostatic discharge risk components must contain notification for the user of the relevant handling regulations.

Packaging

A distinction is made between three types of packing. Electrostatic discharge protection must be provided by **packaging material in direct contact** with the items and by **loose wrappers** intended in particular for the items to be passed on under uncontrolled conditions outside protection zones. Outer packaging, however, does not have to provide ESD protection nor satisfy additional requirements such as protection against mechanical damage.

- **Packaging material in direct contact**
Packaging and auxiliary materials or means of transportation in direct contact with items exposed to ESD risk must be capable of minimising the tribo-electrical charge and ensuring charge dispersion, i.e. they must be both anti-static and electrostatically conductive.
Any film, corrugated board, plastic packs etc. that are used must satisfy this requirement.
- **Loose wrappers**
Loose wrappers used to protect items exposed to ESD risk (voltages up to 4 kV or unknown) outside of ESD protection zones must be electrostatically screened.
If they are used inside electrostatic discharge protection zones or if the parts are less sensitive to risk, the requirements can be reduced.
Loose filling material for packs must be **antistatic and electrically conductive** in order to eliminate any risk to the packed items.
Separate bags can be used as either direct-contact packaging material or loose wrappers.
This presupposes that they provide electrostatic screening, that the inner surface is antistatic and that both surfaces are electrostatically conductive.

- **Outer packaging**

Outer packaging material must satisfy all additional packaging requirements, for example protection against mechanical damage.

No electrostatic properties are required if protection against electrostatic discharge is provided by the inner packaging material. However, the outer material must be antistatic if the pack is to be transported into an ESD protection zone.

Personnel wrist-band earthing (grounding)

Earthing (grounding) by means of a wrist band or strap is the most reliable method of diverting electrostatic charges away from working personnel, and should therefore be used wherever possible, particularly if the person concerned is working while seated.

The wrist band earthing (grounding) device consists of a bracelet closely attached to the wrist and a spiral earthing (grounding) cable connecting it to the earthing (grounding) contact point.

This system must include a quick-release device so that the wrist can be freed in the event of danger.

- **Wrist band**

The inside surface of the wrist band must be electrically conductive, but the outer surface and edges must be electrically insulated.

- **Earthing (grounding) cable**

The earthing (grounding) cable must consist of an insulated wire which, at work areas with a nominal voltage up to 250 V, must be capable of accepting a test voltage of 4 kV without failure.

A metallic-layer resistor rated at not less than 1 MOhm with a load factor of no less than 0.25 W acc. to DIN 45921 Teil 107 (2) must be integrated into the earthing (grounding) cable.

This resistor must also be in accordance with DIN VDE 0860 (20, 21) and must not be capable of being bridged. It is to be installed at the cable end nearest the wrist band.

Total resistance must not exceed 5 MOhm.

The connectors used at earthing (grounding) points must **not fit the sockets of other systems**, e.g. alternating current plugs or laboratory apparatus sockets.

This requirement can be satisfied by the use of suitable pushbutton fittings or suitably insulated plugs.

Banana-pattern plugs in most cases **and crocodile clips in all cases (except for servicing work) are not permitted. Magnets are unsuitable** for earthing (grounding) point connections because they also adhere to painted metal surfaces, but without affording any potential equalisation.

The total **resistance per person** diverted via the wrist band earthing (grounding) device, measured between the person's hand and the earth (ground) potential must be between 0.75 and 35 MOhm.

The rules "**Technical safety requirements for wrist band earthing (grounding)**" issued by the precision mechanical and electrical engineering industrial accident insurers must be complied with.

Shoes and foot earthing (grounding) straps

Electrically conductive shoes should be worn by persons who mainly work standing up or either standing or sitting in electrostatic discharge (ESD) protection zones, particularly if wrist band earthing (grounding) is impracticable. The standard calls for ESD shoes to record values between 0 and 35 MOhm resistance. However, for antistatic working shoes resistance values between 0.1 and 1000 MOhm are called for, and a through-conducting resistance for protective shoes of 0.1 to 100 MOhm. A lower limit value of not less than 0.1 MOhm must be maintained on account of the contact voltage risk.

For this reason the minimum value has been set contrary to the standard at the higher figure of 0.75 MOhm.

◦ Foot earthing (grounding) straps

Persons working temporarily in ESD risk zones (or for example visitors) must be provided with foot earthing straps.

The total **discharge resistance of each person** by way of these shoes or earthing (grounding) straps, measured between hand and earth (ground) potential, must be between 0.75 and 35 MOhm.

Tools

Tools used in ESD protection zones should if possible be made of **electrostatically conductive** material.

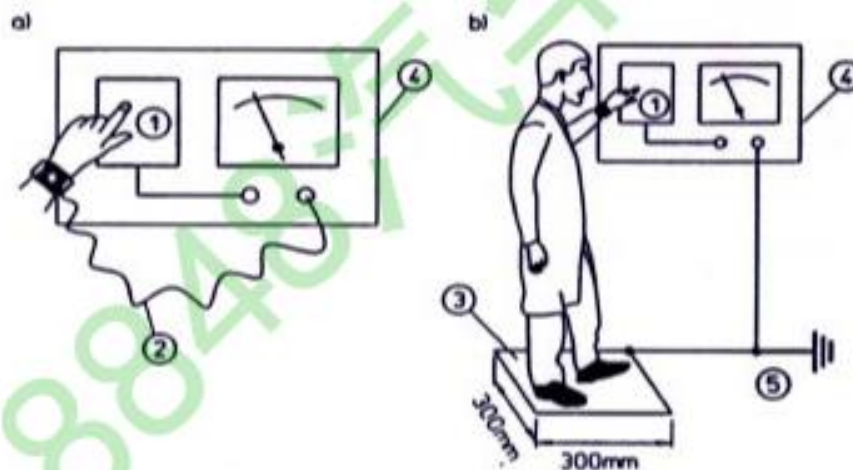

- a** If a wrist earthing (grounding) band is worn
- b** If ESD protective shoes are worn
- 1** Hand contact plate
- 2** Wrist earthing (grounding) band
- 3** Footplate
- 4** Resistance measuring device
- 5** ESD earthing (grounding) system

Individual component installation sequence (electrical circuit) from bottom to top

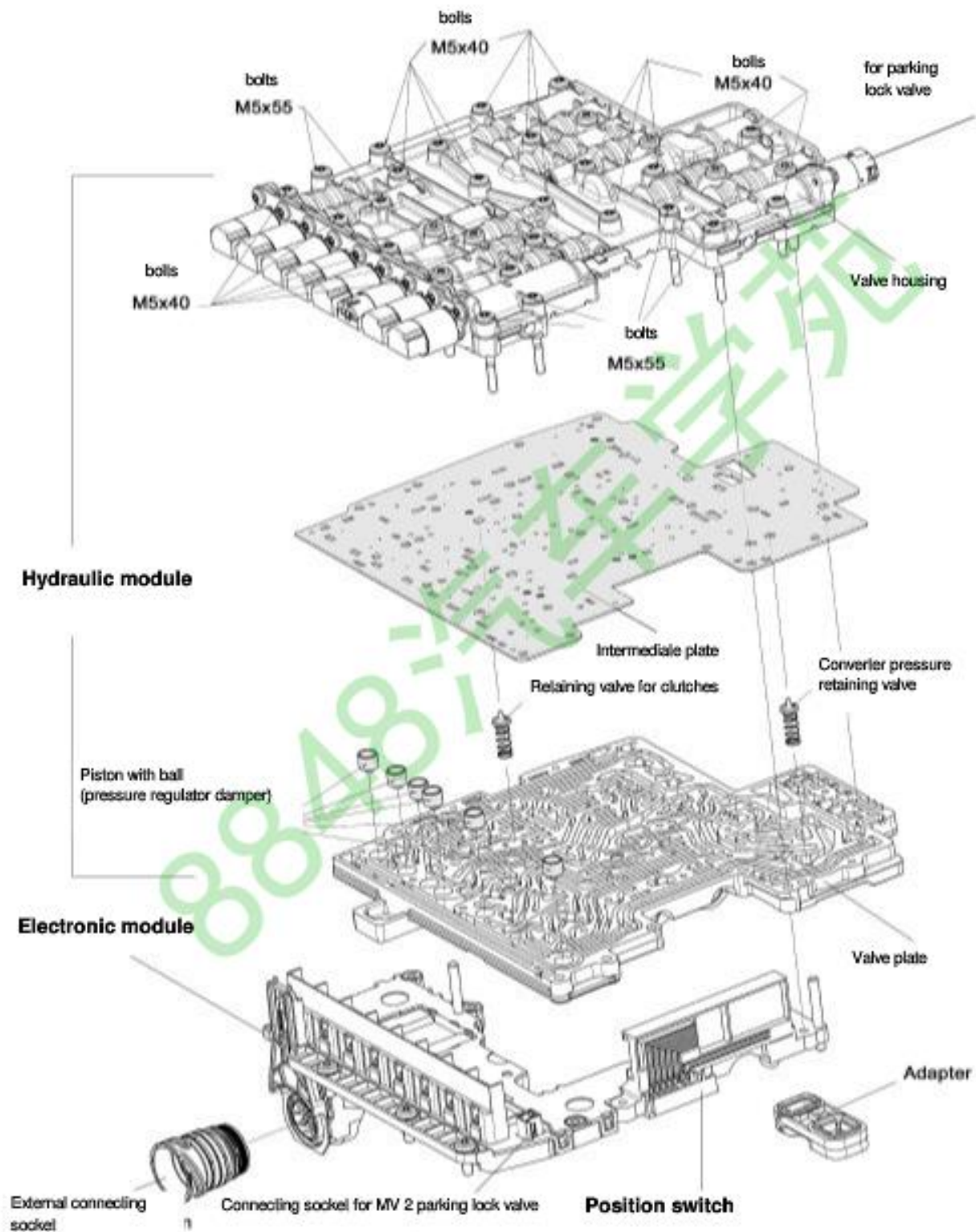

Individual component assembly sequence (M shift) from bottom to top

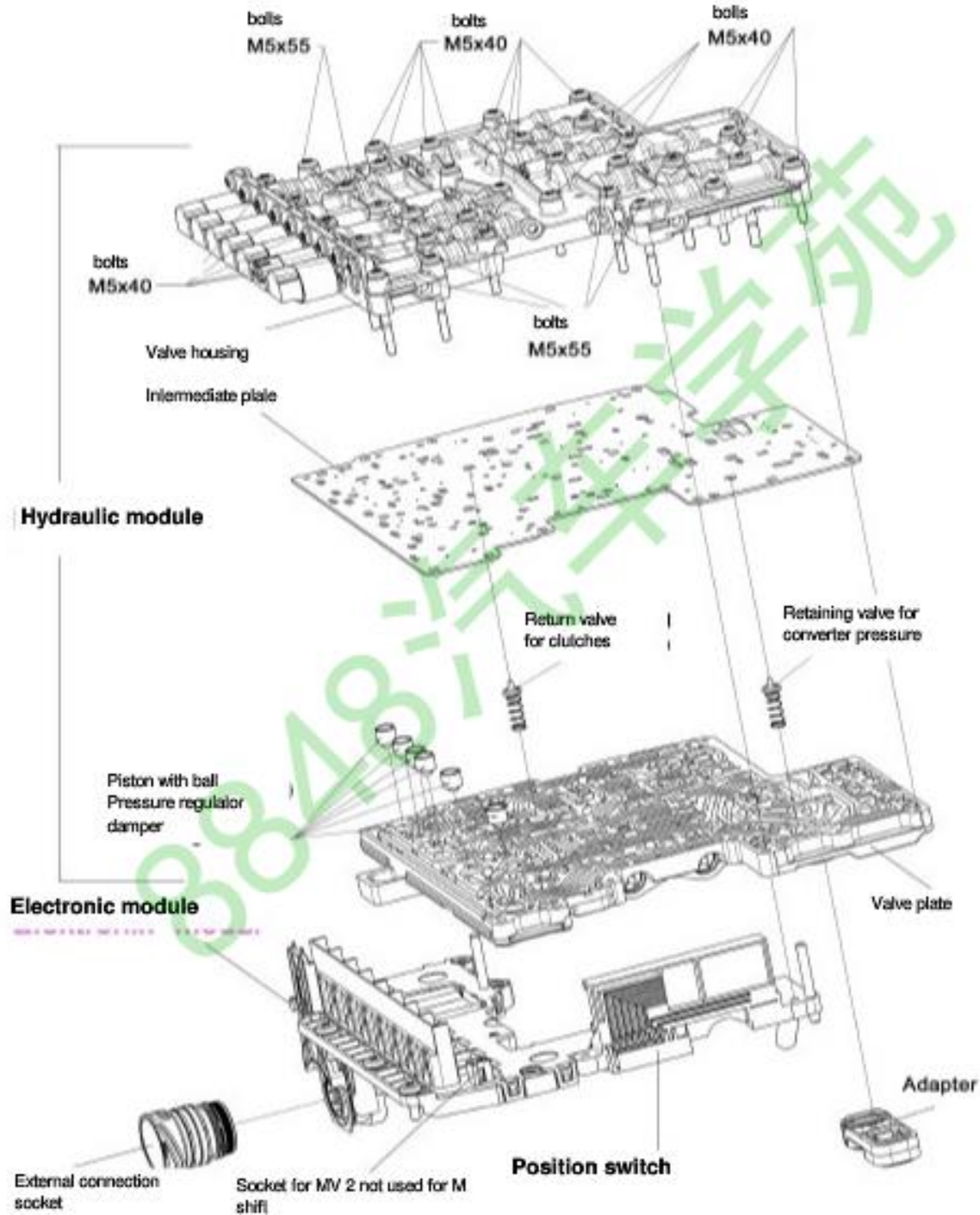

Electrical circuit

When installing the two modules

(hydraulic and electronic)

make sure in particular that the piston of the parking lock cylinder is connected to the position switch - see sketch.

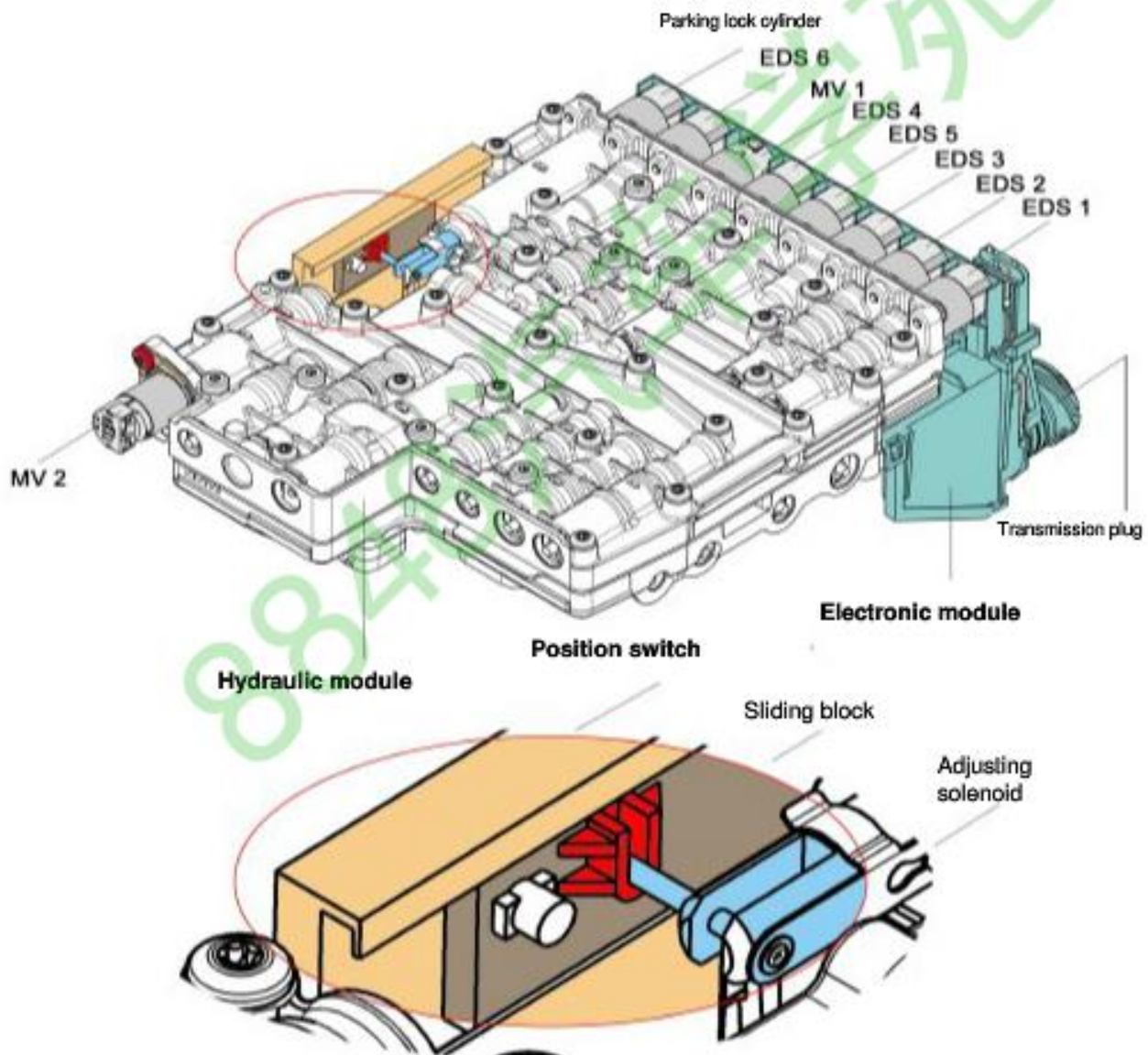

M shift

When installing the two modules

(hydraulic module and electronic module)

make sure in particular that the selector spool valve is connected to the position switch (see sketch).

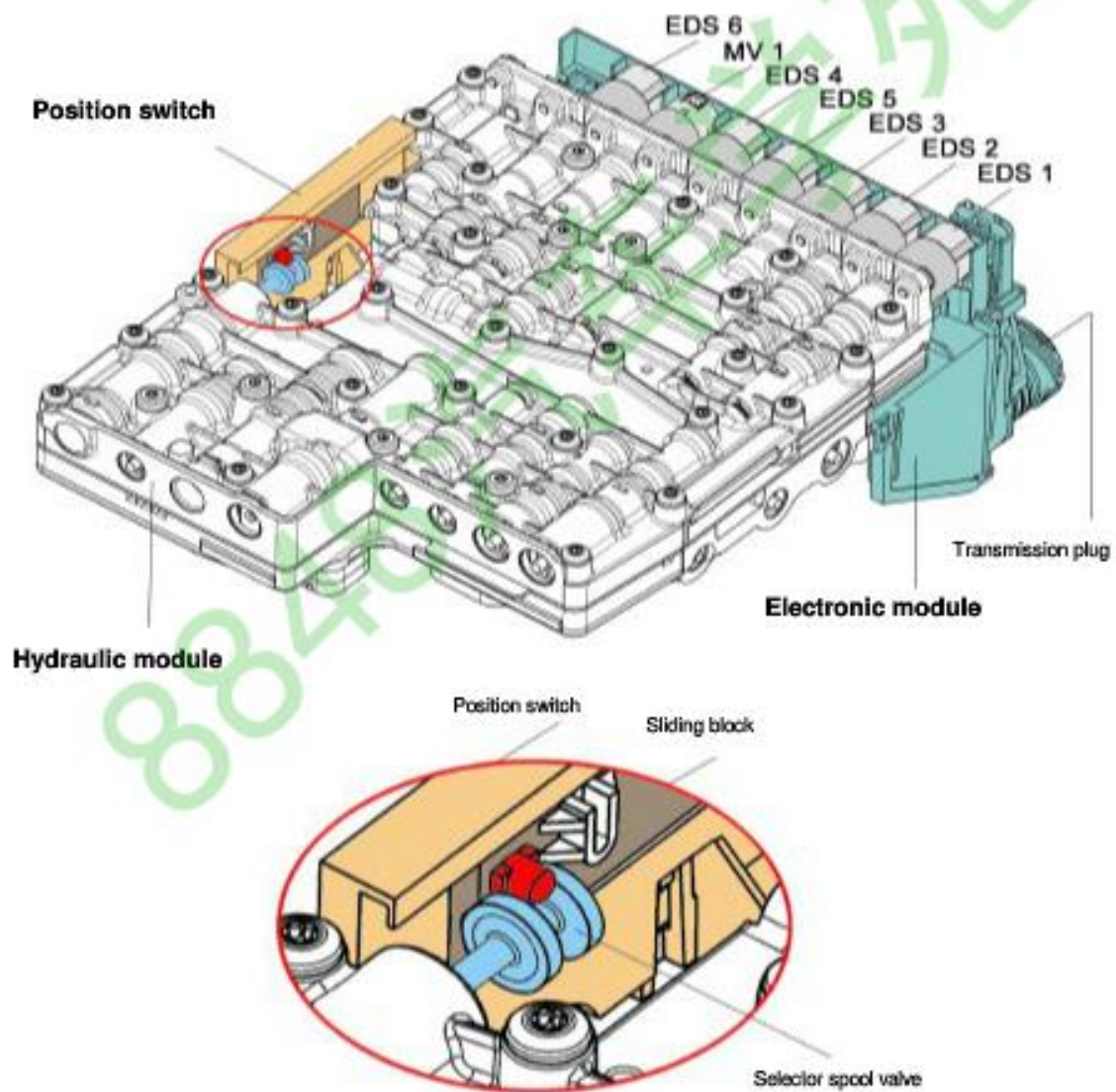

Installed positions of valves in valve housing (E shift)

- Ps-Zyl. = Parking lock cylinder
- SHV1 = Selector valve 1
- SHV2 = Selector valve 2
- HV-D = Retaining brake D
- Dr.Red.-V = Pressure reducing valve

- HV-B = Retaining valve, clutch B
- HV-A = Retaining valve, clutch A
- MV = Solenoid valve
- EDS = Electronic pressure control

Valve housing

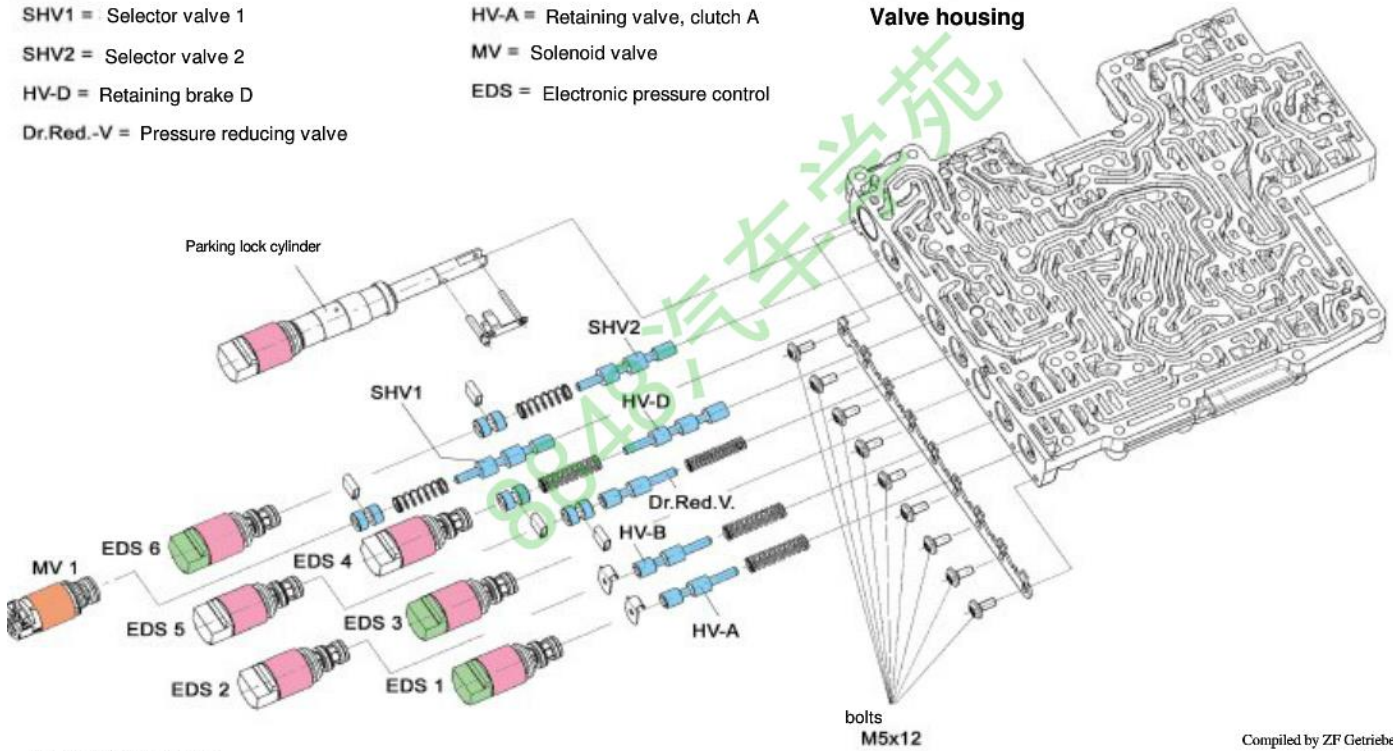

Installed positions of valves in valve housing (M shift)

- SV- Reservoir
- SHV2 = Shift valve 2
- SHV1 = Shift valve 1
- Dr.Red.-V = Pressure reducing valve
- HV- A = Retaining valve, clutch A
- HV- B = Retaining valve, clutch B
- EDS1- 6 = Electronic pressure control 1-6
- MV1 = Solenoid valve 1

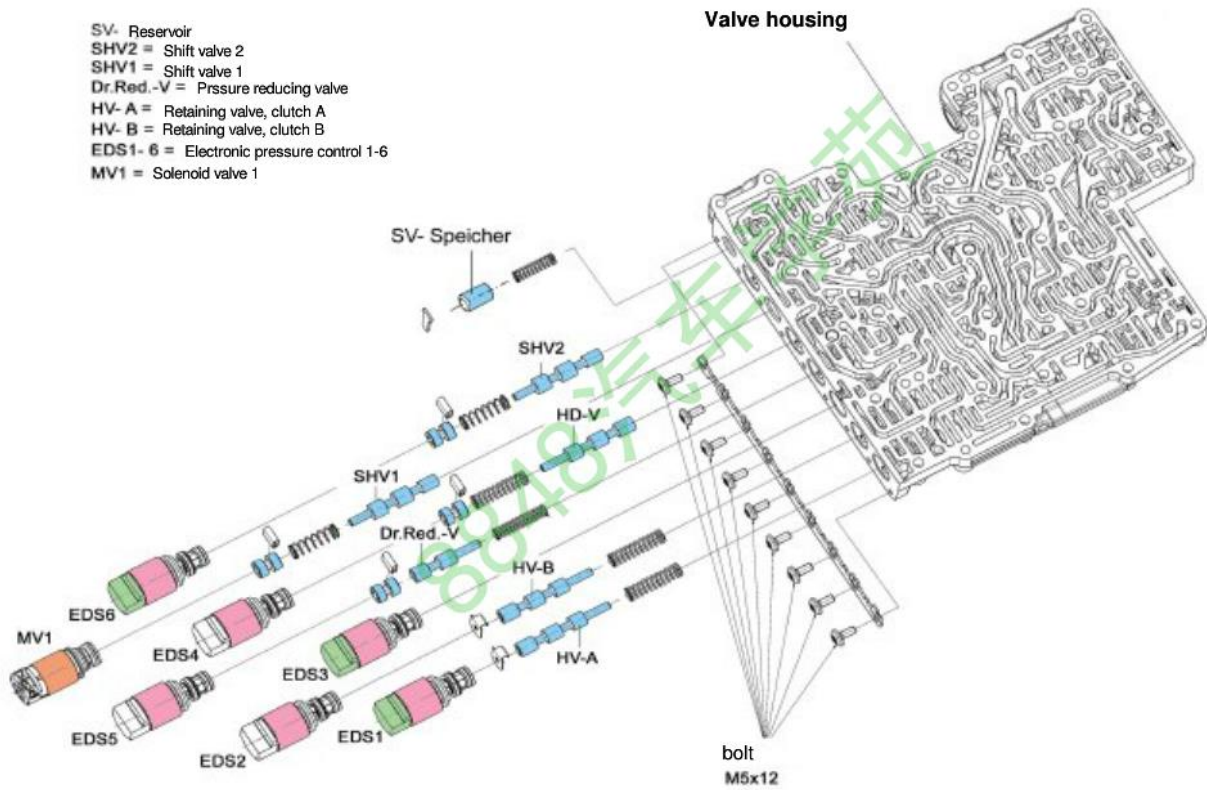

Installed positions of valves in valve housing (E shift)

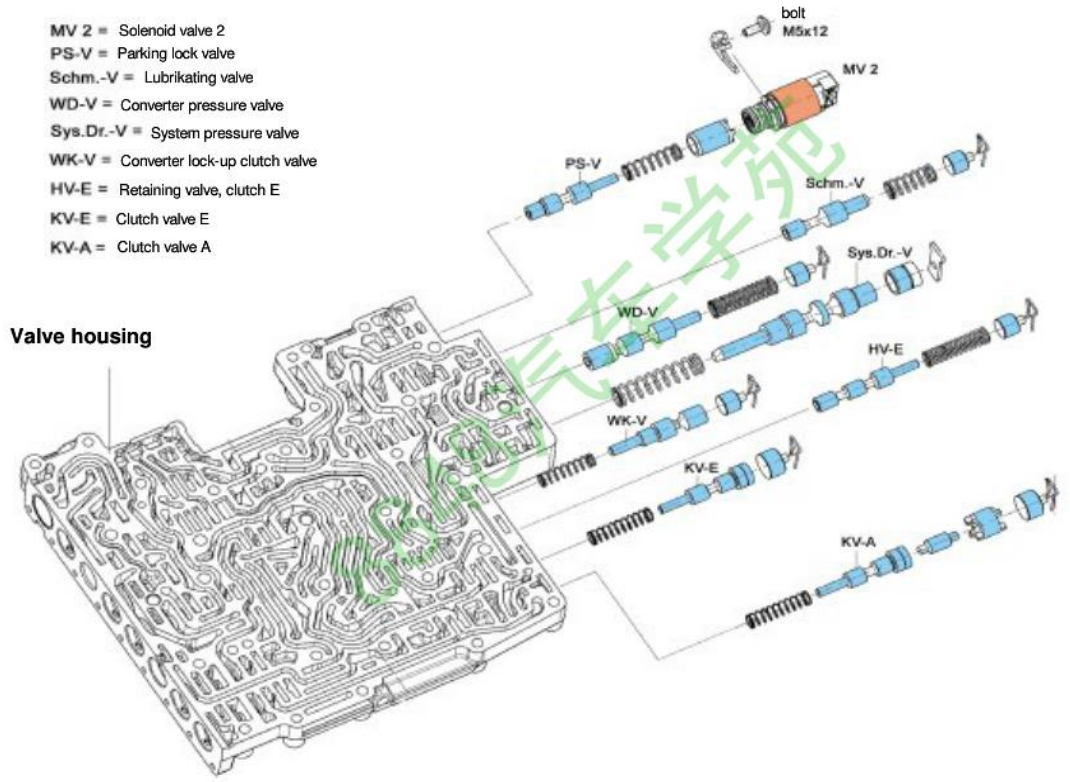

Installed positions of valves in valve housing (M shift)

- WS** = Selector spool valve
- Schm.-V** = Lubricating valve
- WD-V** = Converter pressure valve
- Sys.Dr.-V** = System pressure valve
- WK-V** = Converter clutch valve
- HV-E** = Retaining valve, clutch E
- KV-E** = Clutch valve E
- KV-A** = Clutch valve A

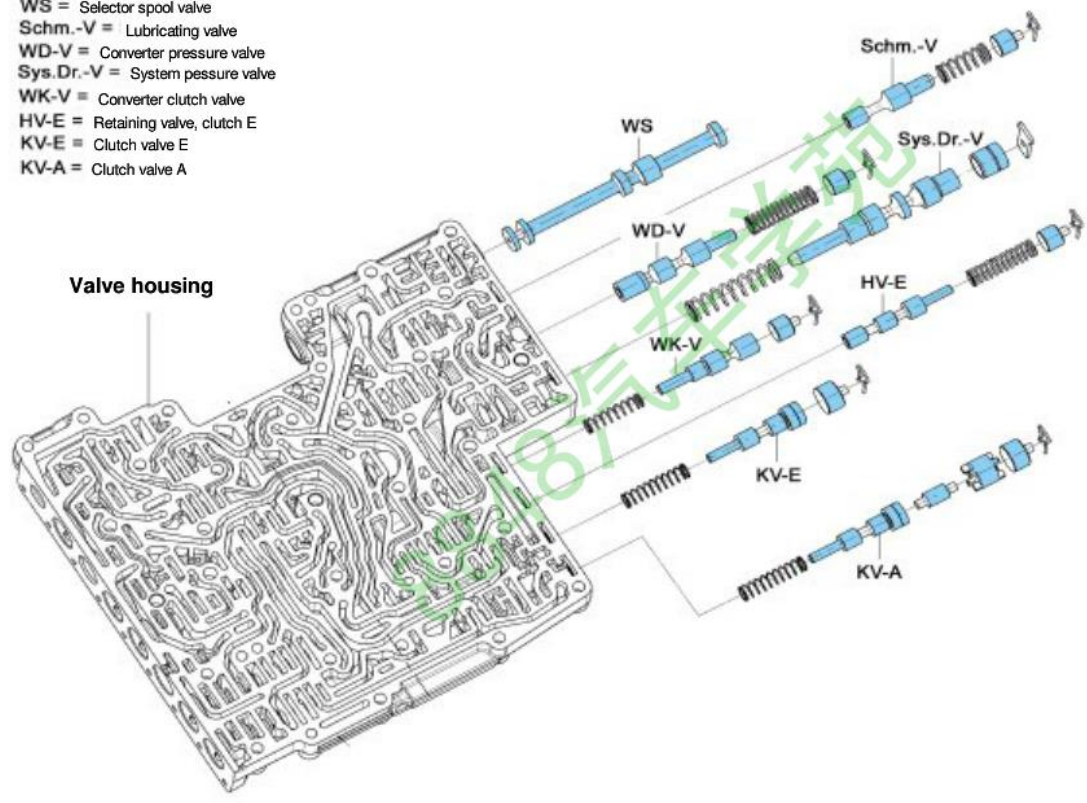

Installed position of valves in valve plate (E shift)

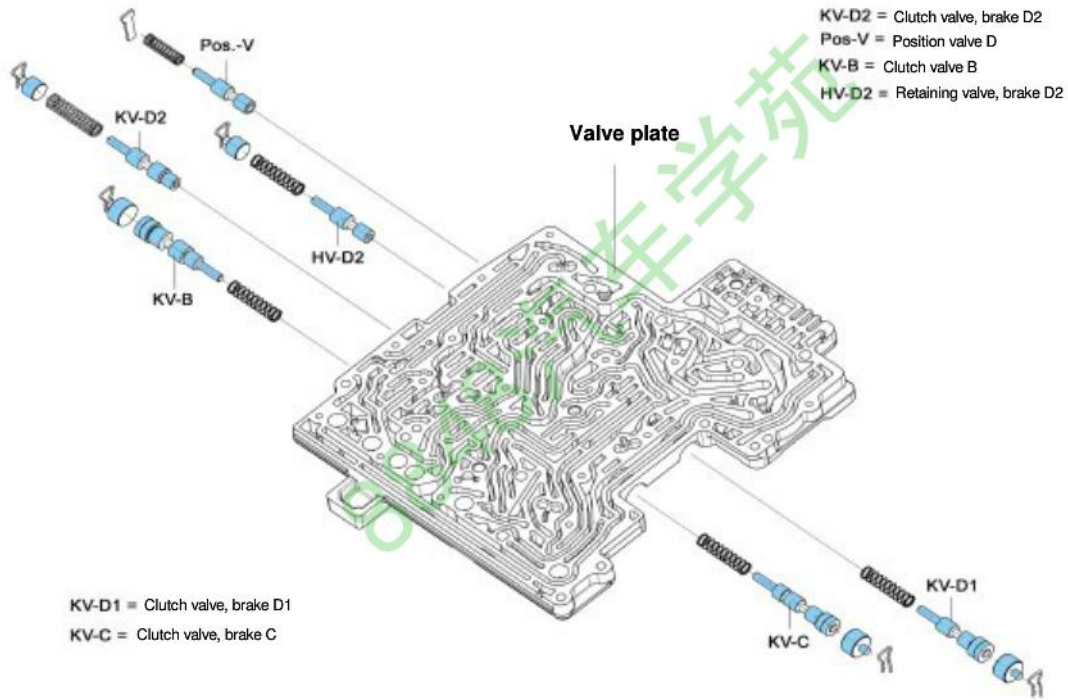

Installed positions of valves in clutch plate (M shift)

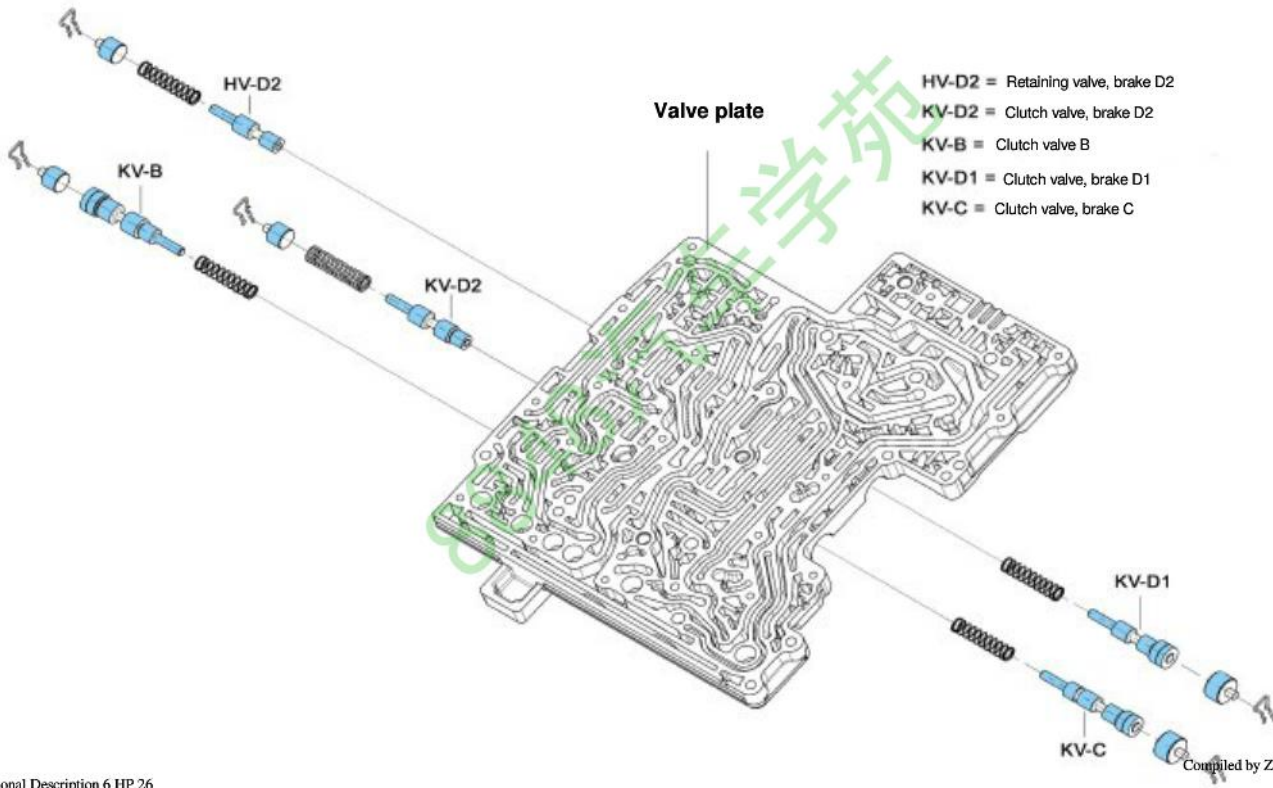

Brief description of valves (M and E shift)

Selector spool valve (WS) only with M shift

The selector spool valve is used by the driver to select the direction of travel (forward or reverse), the parking lock position or neutral.

Parking lock cylinder (PS- ZYL) only with E shift

The parking lock is engaged electrically by the parking lock cylinder. For a detailed description, see page 22, "Parking lock".

Parking lock valve (PS- V) only with E shift

The purpose of the parking lock cylinder is to shift the parking lock cylinder to the Nneutral or Park positions. The PS-V is actuated by solenoid valve 2.

MV2 active = neutral position

MV2 inactive = park position

Shift valve 1-SHV1 (emergency-run valve)

The task of this valve is to keep the gear actually selected in use if the power should fail while driving. If the car is restarted and the EGS is in the emergency program (no power at E actuators), a predetermined gear is selected.

The shift valve's self-sustaining function is cancelled if the car is restarted, but re-activated by the EGS.

Shift valve 2 (SHV2)

Shift valve 2 is actuated by solenoid valve 2 and supplies system pressure to operate the relevant clutches.

Retaining valves, brake D, clutches A,B,E, (HV- D, HV-A, HV- B, HV-E)

The retaining valves actuate the clutch valves, that is to say the regulating function of the clutch valve is shut down by the retaining valve during the shift at the appropriate time, so that clutch pressure rises to the system pressure. Both valves (clutch and retaining valves) are regulated by the corresponding pressure regulator (EDS).

Clutch valves-Clutches A, B, E, brake C, D1,D2, (KV- A, B, E, C, D1, D2)

The clutch valves are variable pressure reducing valves. They are controlled by the relevant electronic pressure control valve (EDS) and determine clutch pressure during the shift.

Pressure reducing valve (Dr.Red.- V)

The pressure reducing valve lowers system pressure to app. 5 bar, which is then applied to the downstream pressure control circuits (EDS1- 6) and solenoid valves (MV1- 2). The pressure control circuits and solenoid valves need a constant feed pressure if they are to function correctly.

Lubricating valve (Schm.- V)

The lubricating valve reduces and guarantees the pressure needed for lubrication. It also imposes an upper limit on the pressure.

Converter pressure valve (WD- V)

The converter pressure valve reduces system pressure and guarantees the pressure needed for the converter. It also limits maximum converter pressure, to prevent the converter from expanding. If EDS 6 is actuated, the oil passage behind the converter lock-up piston is vented.

System pressure valve (Sys.Dr.- V)

The system pressure valve is a variable pressure limiting valve and regulates the oil pressure built up by the primary pump. Excess oil is returned to the pump intake port.

Converter lock-up clutch valve (WK- V)

The converter lock-up clutch valve is controlled jointly with the converter pressure valve by the electronic pressure control (EDS 6). When it operates, the direction of oil flow is reversed. As the converter pressure valve vents the piston chamber behind the converter lock-up clutch, the space in front of it is charged at system pressure via the converter lock-up clutch valve.

Position valve D (Pos.-V) only with E shift

The position valve takes the place of the selector spool valve and diverts system pressure to regulate the individual clutches and brakes. The position valve is actuated by solenoid valve 1 (E shift) and held in the relevant gear by clutches A and E.

Solenoid valves 1, 2 (MV1, MV2)

The hydraulic module contains one (M shift) or two (E shift) 3/2-way solenoid valves, that is to say these valves have 3 unions and 2 switching positions.

The solenoid valves are actuated by the electronic transmission control system and have two functions (open or closed). They are used to switch the positions of valves.



Electronic pressure control valves 1- 6 (EDS1- 6)

The electronic pressure control valves convert an electric current into a proportional hydraulic pressure. They are energised by the electronic module and actuate the valves belonging to the relevant switching elements.

Two types of electronic pressure regulator are installed:

1. Pressure regulator with rising characteristic (EDS1, 3, 6- green cap)
2. Pressure regulator with falling characteristic (EDS2, 4, 5- black cap)

Pressure regulator with rising characteristic (0 mA = 0 bar / 700 mA = 4.6 bar))

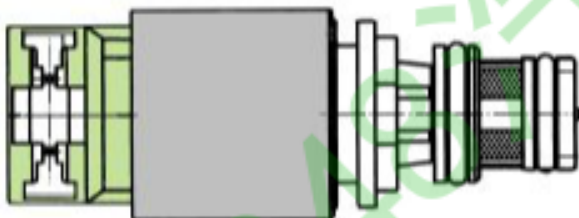

Symbol



Technische Daten

Druckbereich	0 - 4,6 bar
Betriebsspannung	12 V
Widerstand bei 20°C	5,05 Ohm

Technical data:

Pressure range 0 - 4.6 bar
 Operating voltage 12 V
 Resistance at 20 °C 5.05 Ohm

Pressure regulator with falling characteristic (700 mA = 0 bar / 0 mA = 4.6 bar)

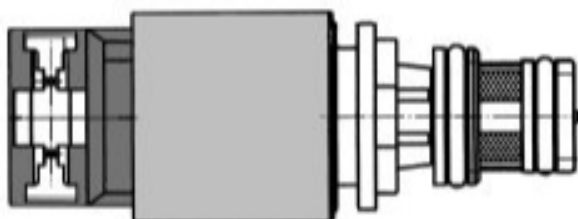

Symbol



Technische Daten

Druckbereich	4,6 - 0 bar
Betriebsspannung	12 V
Widerstand bei 20°C	5,05 Ohm

Technical data:

Pressure range 4.6 - 0 bar
 Operating voltage 12 V
 Resistance at 20 °C 5.05 Ohm

Positions of pressure unions (electrical circuit)

For: System pressure
 Converter lock-up clutch engaged
 Converter lock-up clutch released
 Oil pressure in cooler line
 Clutch A
 Clutch B
 Clutch E
 Brake C
 Brake D1
 Brake D2

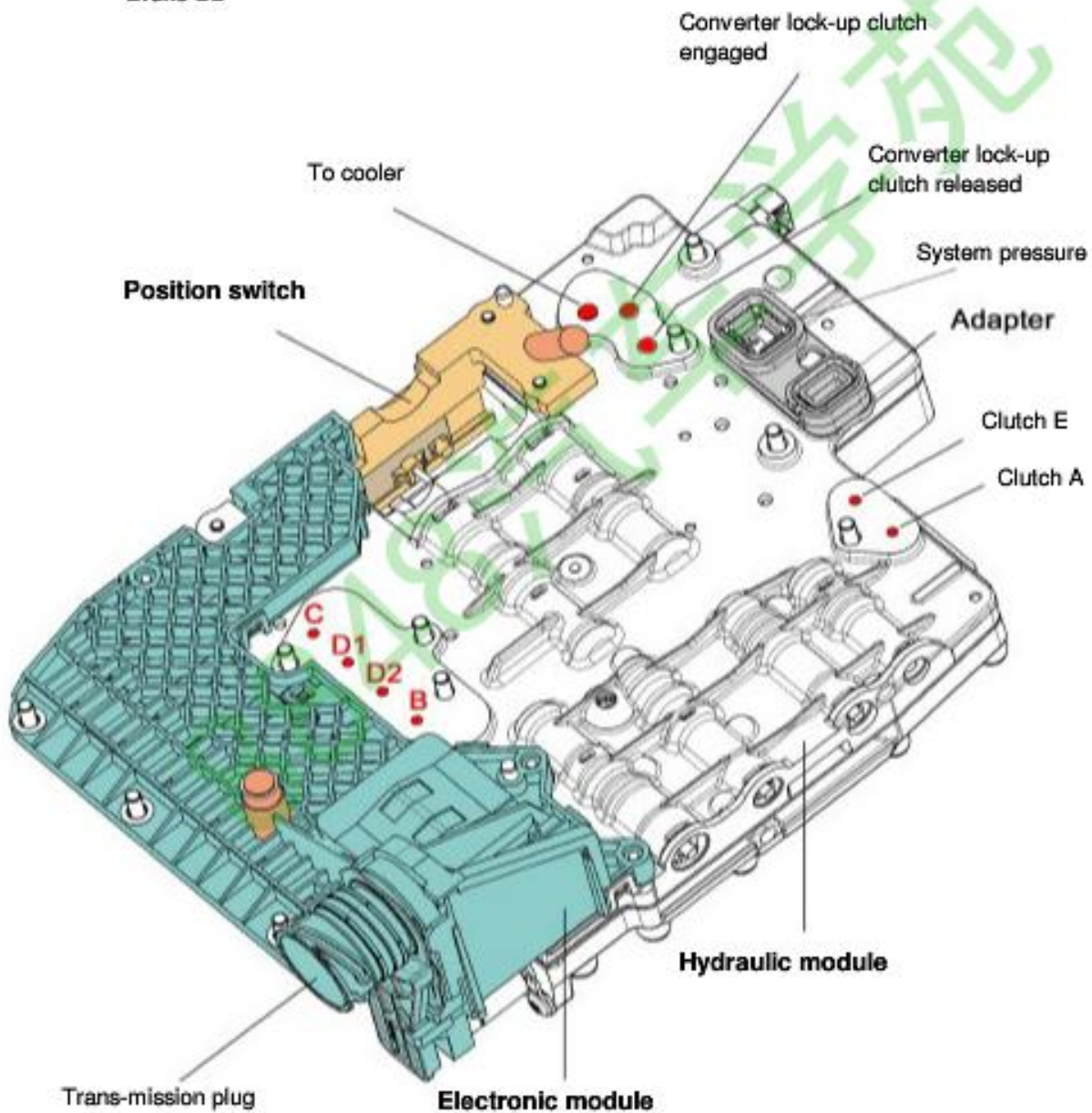

Position of pressure unions (M shift)

For: System pressure
 Converter lock-up clutch engaged
 Converter lock-up clutch released
 Oil pressure in cooler line
 Clutch A
 Clutch B
 Clutch E
 Brake C
 Brake D1
 Brake D2

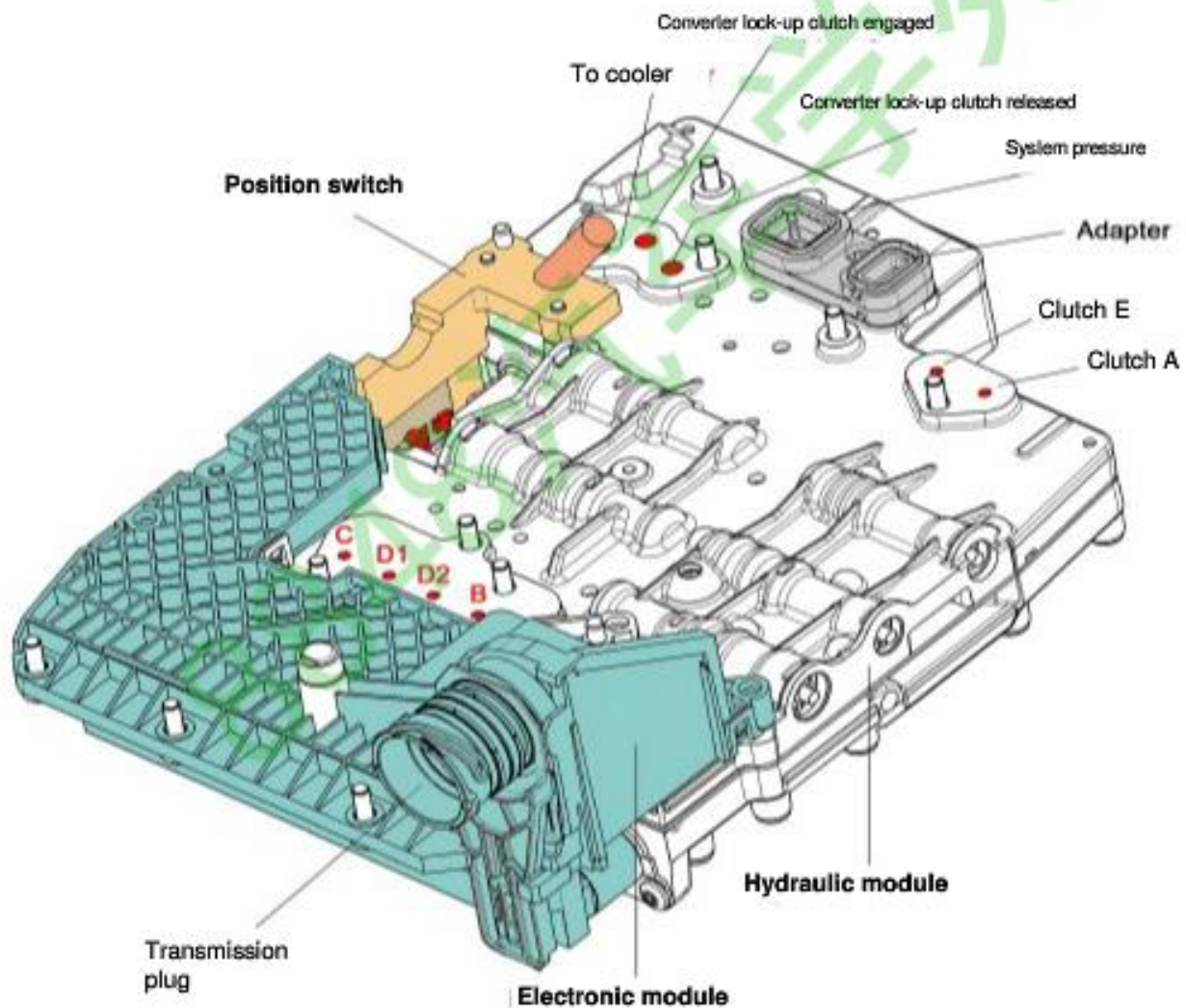

Positions of pressure unions on transmission housing

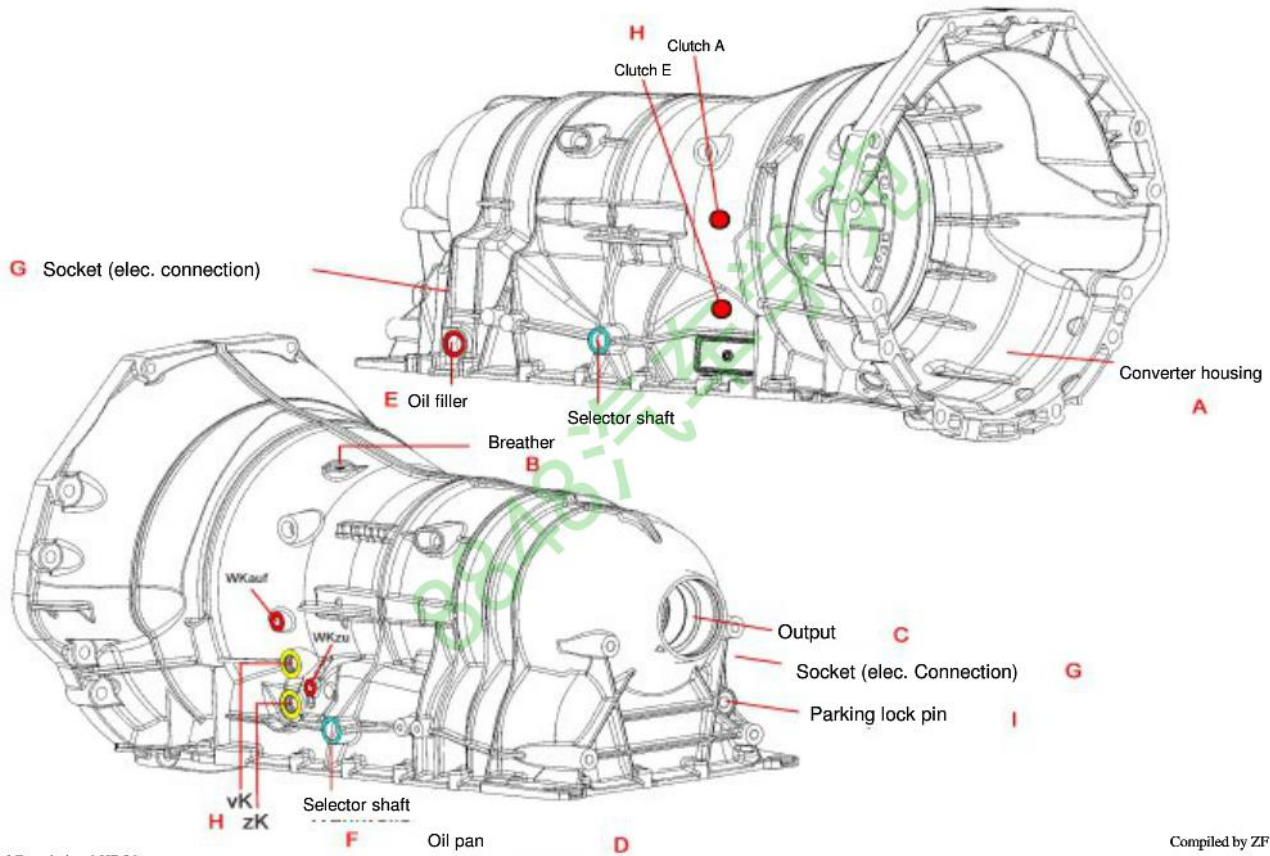

Position of pressure unions on transmission housing

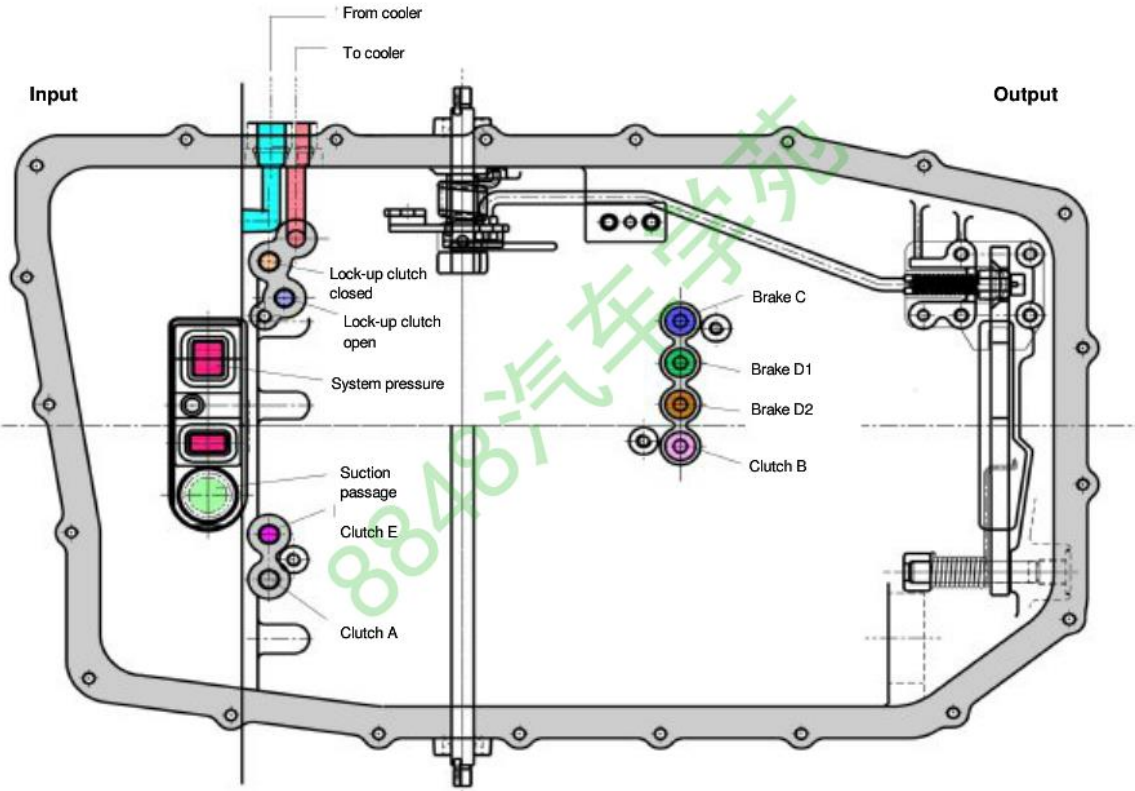

Threaded connections for components (electrical circuit)

M5 screws (electronic module to hydraulic module) 6x
 M6 screws (complete Mechatronik to transmission housing) 10x
 M5 screws (hydraulic module) 18x

- Schrauben M5 (Elektronik-Modul an Hydraulik-Modul) 6x
- Schrauben M6 (Mechatronik kpl. an Getriebegehäuse) 10x
- Schrauben M5 (Hydraulik-Modul) 18x

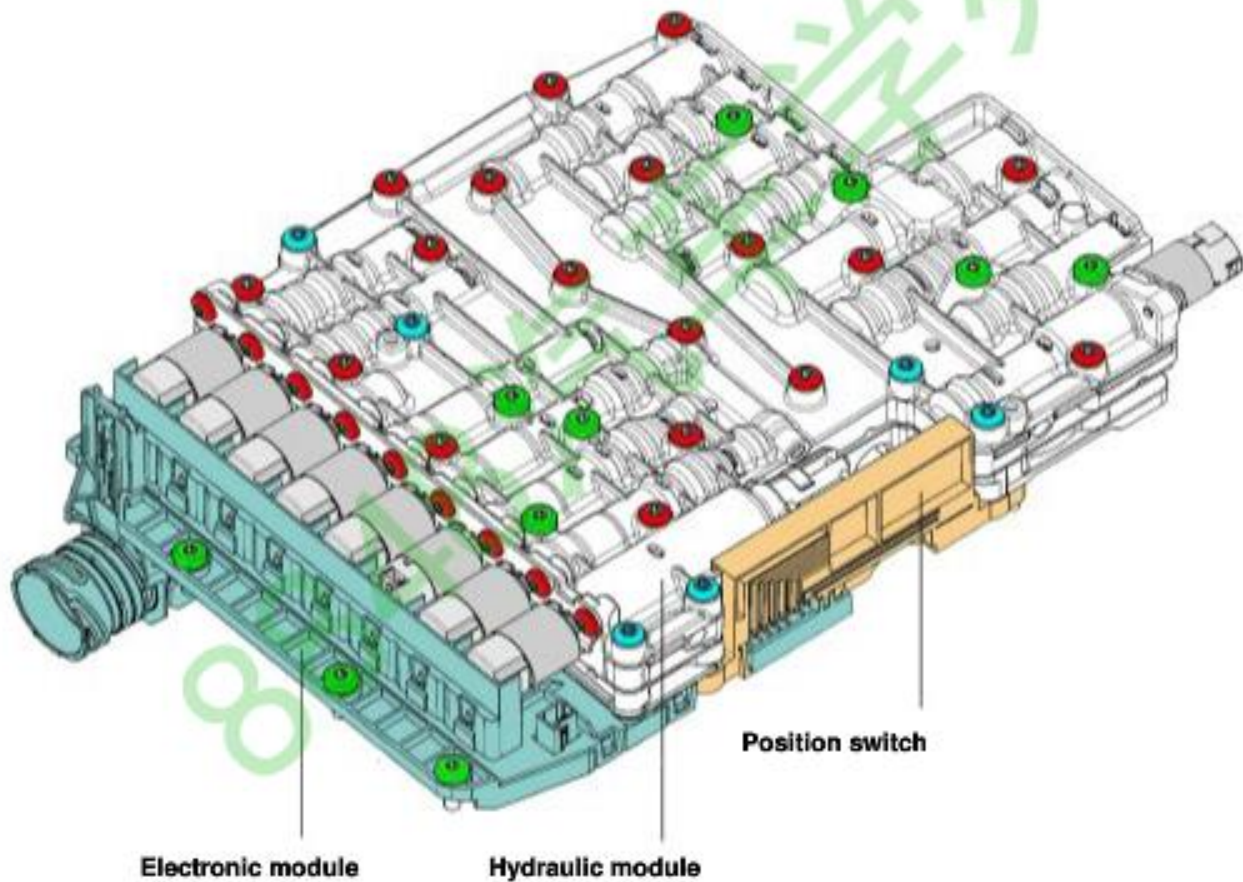

Threaded connections for individual components (M shift)

M5 screws (electronic module to hydraulic module) 6x
 M6 screws (complete Mechatronik to transmission housing) 10x
 M5 screws (hydraulic module) 20x

- Schrauben M5 (Elektronik- Modul an Hydraulik- Modul) 6x
- Schrauben M6 (Mechatronik kpl. an Getriebegehäuse) 10x
- Schrauben M5 (Hydraulik- Modul) 20x

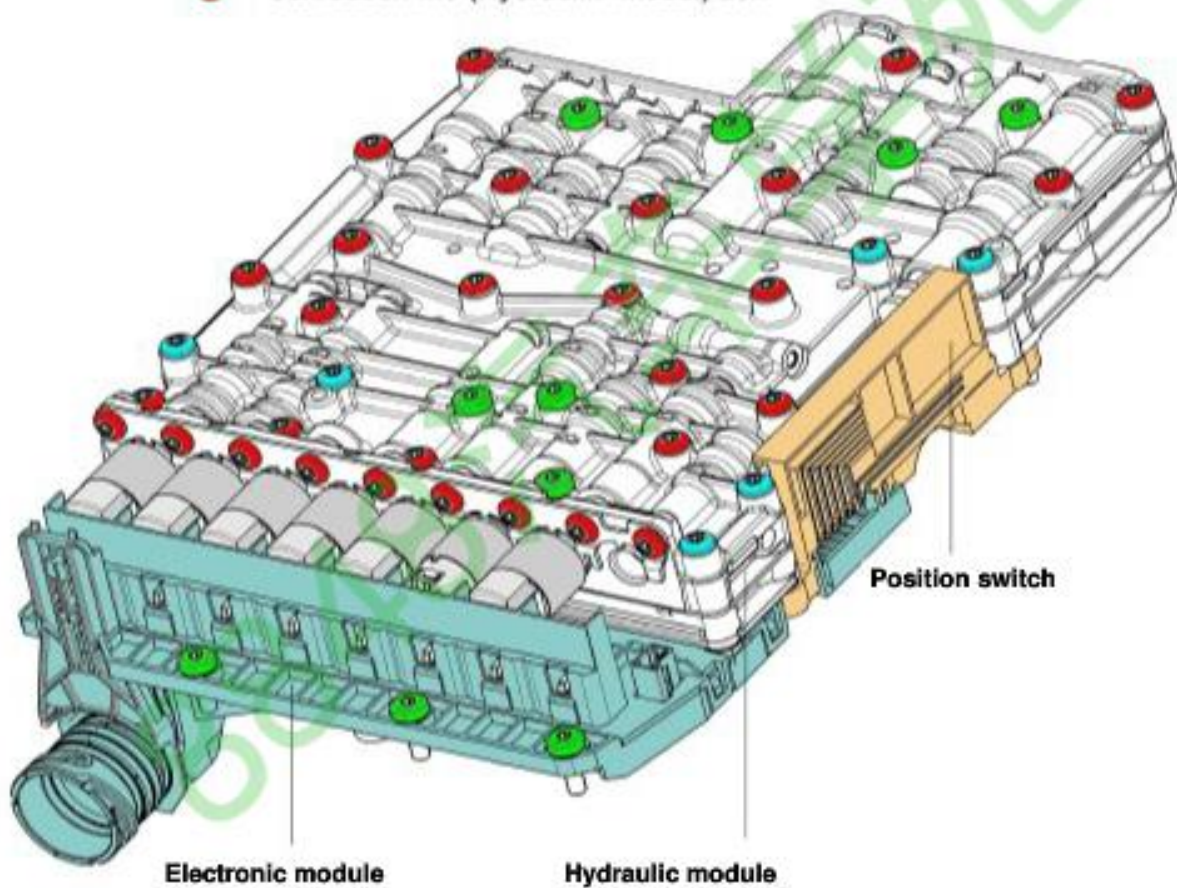

Electronic module (transmission control)

Electronic module

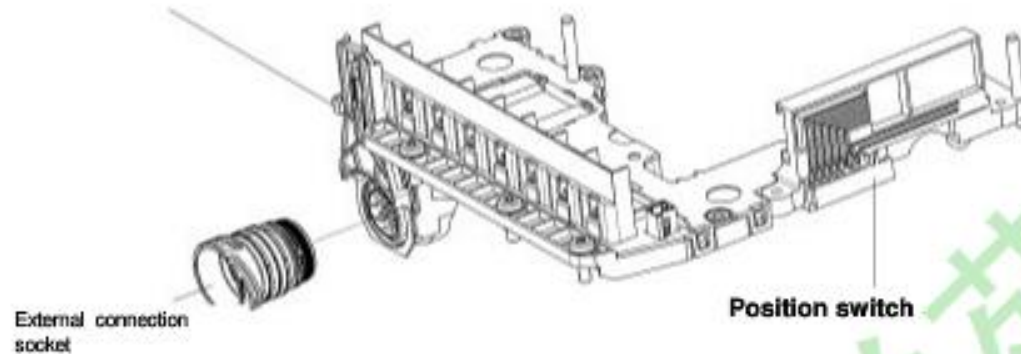

Mechatronik, complete

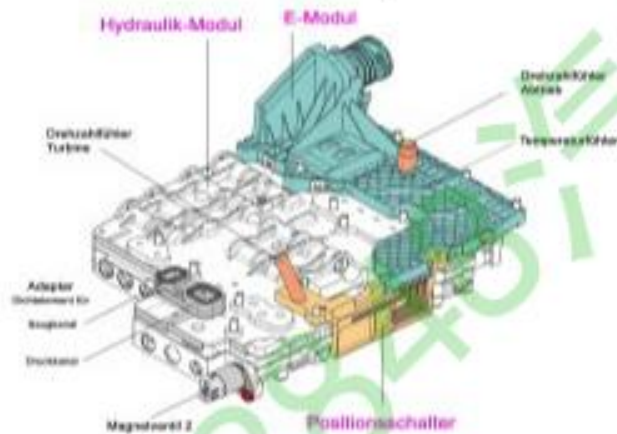

The two speed sensors for the turbine and output speeds, the thermo-sensor and the position switch are **permanently** integrated at the E module.

The electronic module (electronic transmission control, EGS) processes signals from the transmission, the engine and the vehicle.

From the signal inputs and the memorised data the control program computes the correct gear and converter lock-up clutch setting and the optimum pressure settings for gear shift and lock-up clutch control.

By means of special output-side modules (power output stages, current regulator circuits), the EGS controls the solenoid valves and pressure regulators and thus influences the hydraulics of the automatic transmission.

In addition, the amount and duration of engine interventions are supplied to the engine management by way of the CAN bus.

CAN and series line

Signals are always transmitted between the individual items of equipment by the CAN bus.

Controller Area Network (motor-vehicle bus system)

For reasons of availability, signal transmission between SZL and EGS not only uses the bus line but also an additional unidirectional series line from SZL to EGS.

The series line must maintain the same security standard as the CAN link.

The CAN bus is provided with mechanisms (check sum etc.) that ensure the highly reliable transfer of data.

If data are transmitted from one bus line to another, e.g. from K- CAN to P- CAN, the central gateway module forms a link in the data transfer chain.

Schematic communication diagram

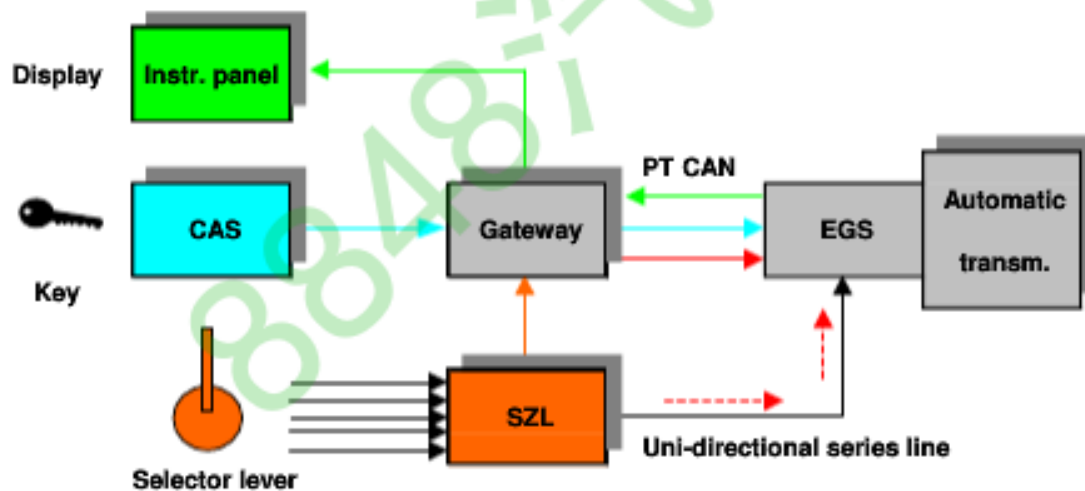

The data that the transmission control unit needs to select the correct gear, for example

[Injection time, engine speed, throttle butterfly angle, engine temperature, engine interventions](#)

are transmitted by the PT CAN bus to the transmission control unit. The solenoid valves and pressure regulating valves are actuated directly from the Mechatronik module.

Signals that can be transmitted via the PT CAN bus to the EGS control unit and thence to other control units are:

Signals	Transmitter	Receiver
Transmission selector switch	SZL	EGS
Terminal status	CAS	EGS
Central locking	CAS	EGS
Transmission data	EGS	CAS
Engine data	DME / DDE	EGS
Wheel rotating speeds	DSC	EGS
Braking requirement	EMF	EGS
Transmission data display	EGS	Instr. panel
Check Control message	EGS	Instr. panel
Torque requirement	EGS	DME
Operating voltage	Power module	EGS
Stationary consumers	EGS	Power module

Transmission turbine and output speeds are detected by Hall-effect sensors, which transmit the values directly to the Mechatronik module.

In the same way the position switch signal is supplied directly to the E module.

The ability to program the transmission control units by flash code is also available here.

The programming procedure is largely based on DME programming, but modified to suit the operations performed by the transmission control units.

The transmission control unit's processor has a 440 kB internal flash memory.. Of this capacity, approx. 370 kB are occupied by the basic transmission program. The remainder, approx. 70 kB, is used to store vehicle-specific application data.

Pressure adaptation takes place automatically during the journey.

After exchange or repair work on the automatic transmission, the pressure adapter must be reset with a suitable tester. After that it is best to carry out a test run and select all the gears in the transmission.

[For further information, see the "ASIS" operating description..](#)

Mechatronik block circuit diagram - 6HP26 BMW

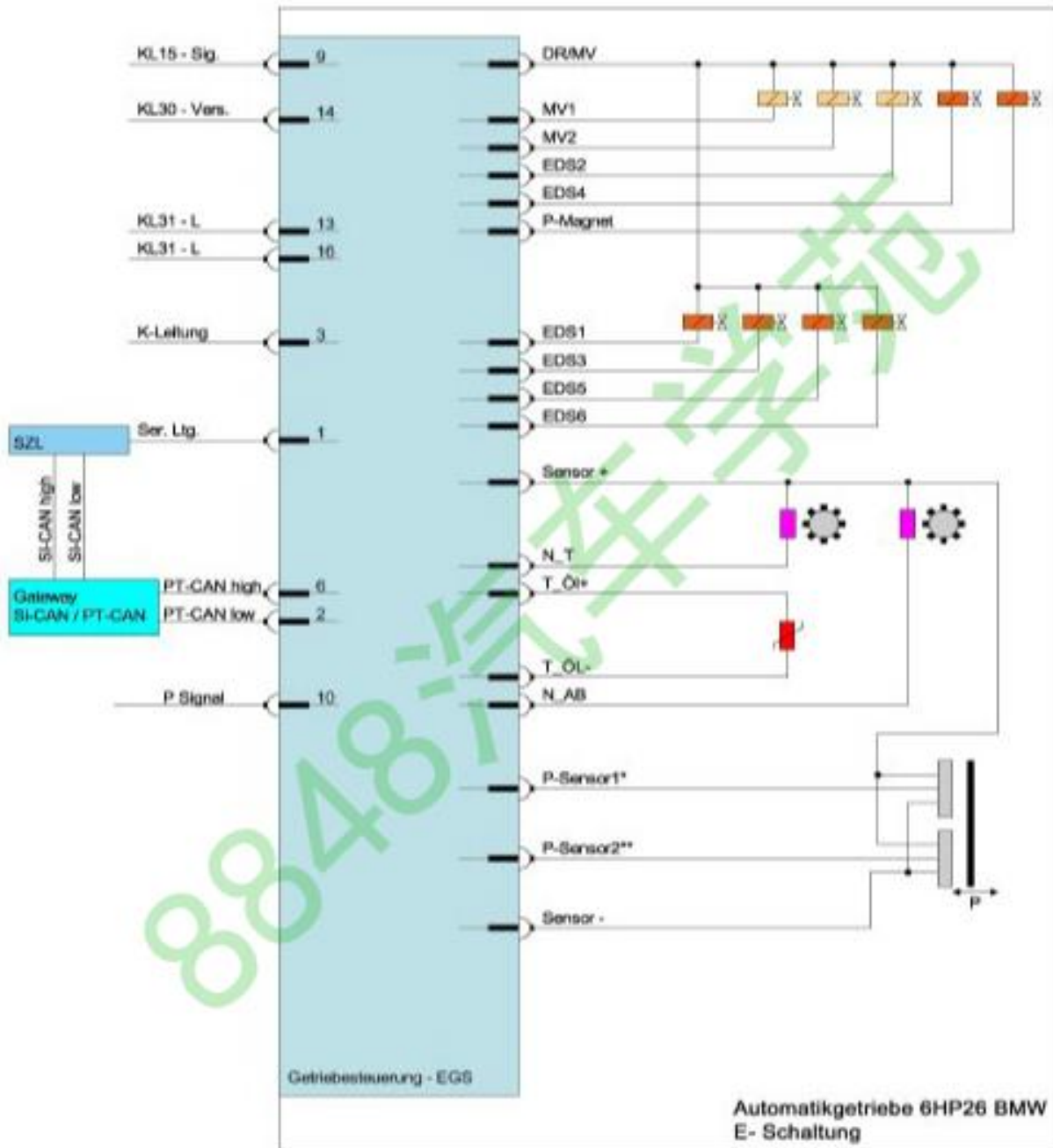

* = L3 vom Positionssensor bei Verwendung des Positionssensors aus 6HP26M
 ** = L4 vom Positionssensor bei Verwendung des Positionssensors aus 6HP26M

Pin assignment at transmission plug - 6HP26 BMW with E-shift

Pin	Assigned to:	Notes:
1	Series line	Availability line from stg. col. switch center
2	CAN L	CAN low
3	ISO K	K line (for example application)
4	not in use	
5	not in use	
6	CAN H	CAN high
7	not in use	
8	not in use	
9	Terminal 15	Wake-up signal, terminal 15
10	P signal	P line for starter inhibit
11	not in use	
12	not in use	
13	Terminal 31-1	Earth (ground)
14	Terminal 30	Permanent positive (EGS supply voltage)
15	not in use	
16	Terminal 31-2	Earth (ground) 2



Mechatronik block circuit diagram - 6HP26 BMW

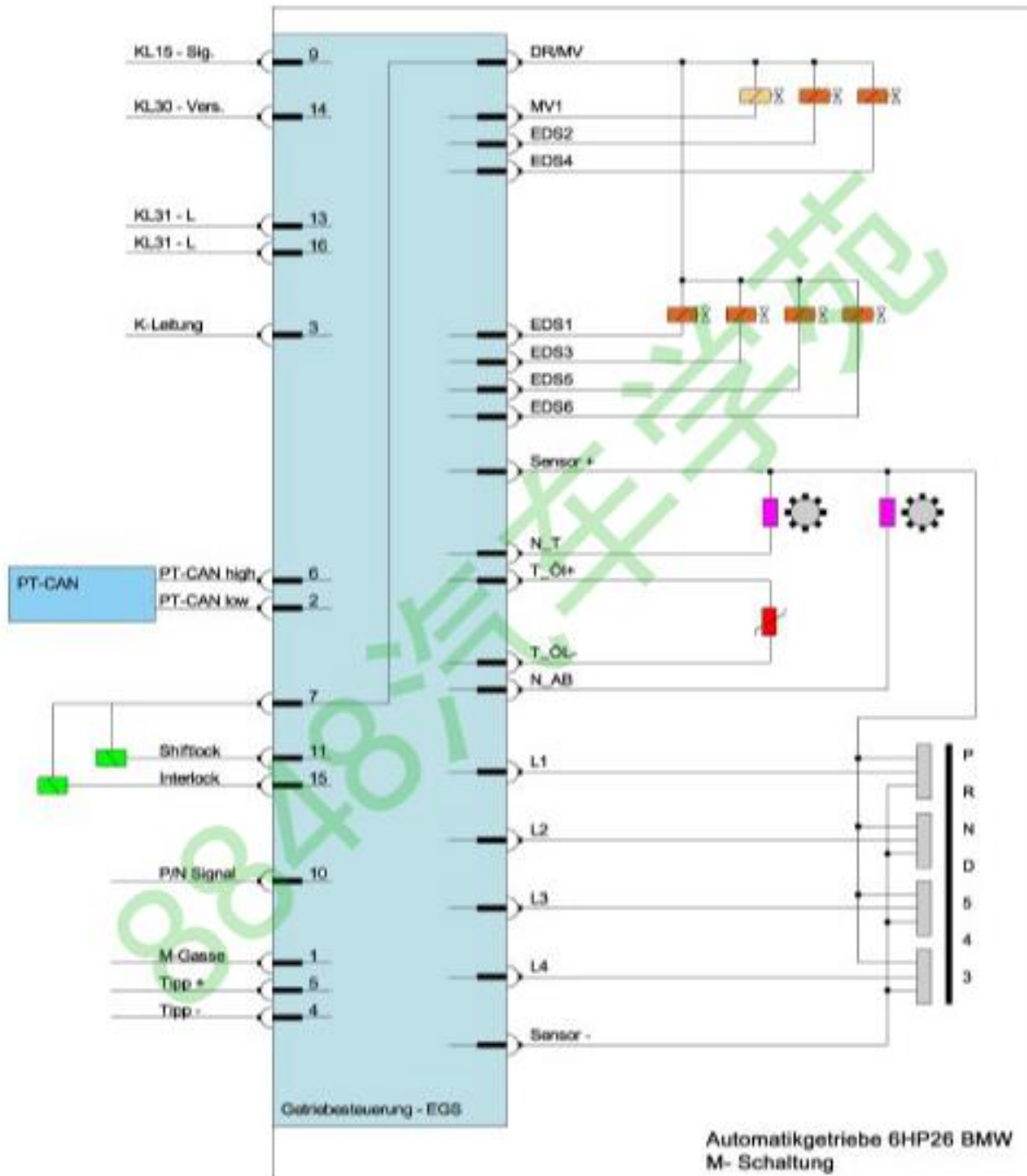

Pin assignment at transmission plug - 6HP26 BMW with M-shift

Pin	Assigned to:	Notes:
1	M gate plane	Manual shift program
2	CAN L	CAN low
3	ISO K	K line (for example application)
4	Touch -	Manual downshift
5	Touch +	Manual upshift
6	CAN H	CAN high
7	Shiftlock	Control signal for Shiftlock and Interlock
8	not in use	
9	Terminal 15	Wake-up signal, terminal 15
10	P signal	P line for starter inhibit
11	Shiftlock	Apply brake before selecting position
12	not in use	
13	Terminal 31-1	Earth (ground)
14	Terminal 30	Permanent positive (EGS supply voltage)
15	Interlock	
16	Terminal 31-2	Earth (ground) 2



6HP19 passenger-car automatic transmission

Technical data

Transmission type	Passenger-car automatic transmission with 6 forward speeds and 1 reverse Standard layout in vehicle						
Transmission capacities	T max Engine at 4000 1/min	= 350 Nm	= 400 Nm **				
	P max	= 180 kW	= 220 kW				
		bei 5500 1/min	bei 6000 1/min				
	n max in 1st - 5th gear	= 7200 1/min	= 6500 1/min				
	n max in 6th gear	= 5600 1/min	= 5600 1/min				
	n max KD- shift	= 6500 1/min	= 6000 1/min				
	T max Turbine forward	= 560 Nm	= 560 Nm				
	T max Turbine reverse	= 300 Nm	= 300 Nm				
	Conditions has to be agreed						
Converter	< 230 Nm: W 235 R 2GWK < 310 Nm: W 245 R 2GWK > 310 Nm: W 255 RH 2GWK optional: W 255 RH 2GWK TD						
Gear Ratio	1.	2.	3.	4.	5.	6.	R
	4,17	- 2,34	- 1,52	- 1,14	- 0,87	- 0,69	/ - 3,40
Positions	P, R, N, D Electronic shift available						
Control system	Mechatronik (Elektrohydraulic) Controlled on-load shifts Various shift programs available						
Weight (with oil)	< 310 Nm	72,0 kg / 350 Nm					
	> 310 Nm	75,0 kg / 400 Nm					
	> 310 Nm	76,5 kg / with torsion damper					

6HP19 A passenger-car automatic transmission

Technical data

Transmission type	Passenger-car automatic transmission with 6 forward speeds and 1 reverse 4 wheel drive layout in vehicle						
Transmission capacities	T max Engine at 4000 1/min	= 350 Nm	= 400 Nm **				
	P max	= 180 kW	= 220 kW				
		bei 5500 1/min	bei 6000 1/min				
	n max in 1st - 5th gear	= 7200 1/min	= 6500 1/min				
	n max in 6th gear	= 5600 1/min	= 5600 1/min				
	n max KD- shift	= 6500 1/min	= 6000 1/min				
	T max Turbine forward	= 560 Nm	= 560 Nm *				
	T max Turbine reverse	= 300 Nm	= 300 Nm				
	Slipping moment limit in the 1st gear Conditions has to be agreed						
Converter	< 230 Nm: W 235 R 2GWK < 310 Nm: W 245 R 2GWK > 310 Nm: W 255 RH 2GWK optional: W 255 RH 2GWK TD						
Gear	1.	2.	3.	4.	5.	6.	R
Ratio	4,17 - 2,34 - 1,52 - 1,14 - 0,87 - 0,69 / - 3,40						
Head gear (head set)	2,7 ... 4,5 Levels in 6% steps						
Moment distribution							
Front axle / rear axle	50 / 50						
Positions	P, R, N, D Electronic shift available						
Control system	Mechatronic (Elektrohydraulic) Controlled on-load shifts Various shift programs available						
Weight (with oil)	< 310 Nm 109,0 kg / 350 Nm > 310 Nm 112,0 kg / 400 Nm > 310 Nm 113,5 kg / with torsion damper						

6HP19 A passenger-car automatic transmission

Technical data

Transmission type	Passenger-car automatic transmission with 6 forward speeds and 1 reverse 4 wheel drive layout in vehicle					
Transmission capacities	T max	Engine at 4000 1/min	=	420 Nm		
	P max		=	236 kW		
					bei 6000 1/min	
	n max	in 1st - 5th gear	=	7000 1/min		
	n max	in 6th gear	=	5600 1/min		
	n max	KD- shift	=	6300 1/min		
	T max	Turbine forward	=	560 Nm *		
	T max	Turbine reverse	=	300 Nm		
	Slipping moment limit in the 1st gear					
Converter	bis 300 Nm: W 245 bis 400 Nm: W 255 With controlled-slip lock-up clutch Tp = 90 - 230 Nm at np = 2000 1/min					
Gear	1.	2.	3.	4.	5.	6. R
Ratio	4,17 - 2,34 - 1,52 - 1,14 - 0,87 - 0,69 / - 3,40					
Head gear (head set)	2,7 ... 4,5 Levels in 6% steps					
Moment distribution						
Front axle / rear axle	50 / 50					
Positions	P, R, N, D Electronic shift available					
Control system	Mechatronik (Elektrohydraulic) Controlled on-load shifts Various shift programs available					
Weight (with oil)	114 kg (gilt für W 245 with out torsion damper)					

6HP26 passenger-car automatic transmission

Technical data

Transmission type:	Passenger-car automatic transmission with 6 forward speeds and 1 reverse Standard layout in vehicle							
Transmission capacities:	T max	Engine at 4200 1/min						= 600 Nm
	P max	Engine at 5800 1/min						= 320 kW
	n max	in 1st - 5th gear 1/min						= 6200 1/min
	n max	in 6th gear 1/min						= 5000 1/min
	n max	KD shift 1/min						= 6000 1/min
	T max	Turbine forward						= 800 Nm
	T max	Turbine reverse						= 500 Nm
Converter:	With controlled-slip lock-up clutch in gears 1- 6 and Reverse							
	Permissible continuous speed							= 7000 1/min
	Tp = 220- 412 at Mp							= 2000 1/min
Gear:	1st	2nd	3rd	4th	5th	6th	Reverse	
Ratio:	4.171	2.340	1.521	1.143	0.867	0.691	- 3.E2861403	
Positions:	Provision for mechanical shift with choice of 8 selector lever positions P, R, N, D, 5, 4, 3, 2							
Control system:	Electrohydraulic (Mechatronik) Controlled on-load shifts Various shift programs available (ASIS)							
Weight:	app. 89 kg with oil							

6HP26 A passenger-car automatic transmission

Technical data

Transmission type	Passenger-car automatic transmission with 6 forward speeds and 1 reverse 4 wheel drive layout in vehicle						
Transmission capacities	T max Engine at 4200 1/min	= 440 Nm	= 600 Nm				
	P max	= 230 kW bei 6600 1/min	= 320 kW bei 5800 1/min				
	n max in 1st - 5th gear	= 7200 1/min	= 6200 1/min				
	n max in 6th gear	= 5600 1/min	= 5000 1/min				
	n max KD- shift	= 7000 1/min	= 6000 1/min				
	T max Turbine forward	= 700 Nm	= 800 Nm				
	T max Turbine reverse	= 400 Nm	= 500 Nm				
Converter	W 260 S - 2 WK < Tmax Motor 440 Nm with controlled-slip lock-up clutch Tp = 120 - 300 Nm bei np = 2000 1/min W 280 S - 2 WK < Tmax Motor 440 Nm with controlled-slip lock-up clutch Tp = 210 - 410 Nm at np = 2000 1/min						
Gear	1.	2.	3.	4.	5.	6.	R
Ratio	4,17 - 2,34 - 1,52 - 1,14 - 0,87 - 0,69 / - 3,40						
Head gear (head set)	2,7 ... 3,7						
Moment distribution							
Front axle / rear axle	50 / 50						
Positions	P, R, N, D Mechanical or electronic shifts						
Control system	Mechatronik (Elektrohydraulic) Controlled on-load shifts Various shift programs						
Weight (with oil)	129 kg / 440 Nm 136 kg / 600 Nm						

6HP26 A 61 passenger-car automatic transmission

Technical data

Transmission type	Passenger-car automatic transmission with 6 forward speeds and 1 reverse 4 wheel drive layout in vehicle						
Transmission capacities	T max Engine at 4200 1/min	= 440 Nm	= 600 Nm				
	P max	= 230 kW	= 320 kW				
		bei 6600 1/min	bei 5800 1/min				
	n max im 1st - 5th gear	= 7200 1/min	= 6200 1/min				
	n max in 6th gear	= 5600 1/min	= 5000 1/min				
	n max KD- shift	= 7000 1/min	= 6000 1/min				
	T max Turbine forward	= 700 Nm	= 800 Nm				
	T max Turbine reverse	= 400 Nm	= 500 Nm				
Converter	W 260 S - 2 WK < Tmax Motor 440 Nm with controlled-slip lock-up clutch						
	Tp = 120 - 300 Nm at np = 2000 1/min						
	W 280 S - 2 WK < Tmax Motor 440 Nm with controlled-slip lock-up clutch						
	Tp = 210 - 410 Nm at np = 2000 1/min						
Gear	1.	2.	3.	4.	5.	6.	R
Ratio	4,17 - 2,34 - 1,52 - 1,14 - 0,87 - 0,69 / - 3,40						
Head gear (head set)	2,7 ... 3,7						
Moment distribution							
Front axle / rear axle	50 / 50						
Positions	P, R, N, D						
	Mechanical or electronic shifts						
Control system	Mechatronic (Elektrohydraulic) Controlled on-load shifts Various shift programs						
Weight (with oil)	136 kg / 440 Nm 143 kg / 600 Nm						

6HP32 passenger-car automatic transmission

Technical data

Transmission type	Passenger-car automatic transmission with 6 forward speeds and 1 reverse Standard layout in vehicle		
		Diesel	Benzin
Transmission capacities	T max Engine	= 750 Nm bei 2500 1/min	= 700 Nm bei 4000 1/min
	P max	= 320 kW bei 4500 1/min	= 320 kW bei 5700 1/min
	n max in 1st - 5th gear	= 5000 1/min	= 6000 1/min
	n max in 6th gear	= 4000 1/min	= 4700 1/min
	n max KD- shift	= 4800 1/min	= 5800 1/min
	T max Turbine forward	= 1000 Nm	= 1000 Nm
	T max Turbine reverse	= 600 Nm	= 600 Nm
Converter	W 300 S - 2 WK with controlled-slip lock-up clutch		
	Tp = 440 - 600 Nm at np = 2000 1/min		
Gear Ratio	1. 2. 3. 4. 5. 6. R		
	4,17 - 2,34 - 1,52 - 1,14 - 0,87 - 0,69 / - 3,40		
Positions	P, R, N, D Electronic shift		
Control system	Mechatronik (Elektrohydraulic) Controlled on-load shifts Various shift programs		
Weight (with oil)	99 kg / with out torsion damper 103 kg / with torsion damper		

6HP32 A passenger-car automatic transmission

Technical data

Transmission type Passenger-car automatic transmission with 6 forward speeds and 1 reverse
4 wheel drive layout in vehicle

		Diesel	Benzin
Transmission capacities	T max Engine	= 750 Nm at 2500 1/min	= 700 Nm at 4000 1/min
	P max	= 320 kW at 4500 1/min	= 340 kW at 5200 1/min
	n max in 1st - 5th gear	= 5000 1/min	= 6000 1/min
	n max in 6th gear	= 4000 1/min	= 4800 1/min
	n max KD- shift	= 4800 1/min	= 5800 1/min
	T max Turbine forward	= 1000 Nm	= 1000 Nm
	T max Turbine reverse	= 600 Nm	= 600 Nm

Converter W 300 S - 2 WK with controlled-slip lock-up clutch

$T_p = 440 - 600 \text{ Nm}$ at $n_p = 2000 \text{ 1/min}$

Gear	1.	2.	3.	4.	5.	6.	R
Ratio	4,17	2,34	1,52	1,14	0,87	0,69	- 3,40
Head gear (head set)	2,12 ... 2,57						

Moment distribution
Front axle / rear axle 50 / 50

Positions P, R, N, D
Mechanical or electronic shifts

Control system Mechatronik (Elektrohydraulic)
Controlled on-load shifts
Various shift programs

Weight (with oil) 159 kg