

Brake System Bleeding - VIN Range: G00442->G45703 (70.25.03)



WARNING: Brake Fluid contains polyglycol ethers and polyglycols. Avoid contact with the eyes. Wash hands thoroughly after handling, as prolonged contact may cause irritation and dermatitis. If brake fluid contacts the eyes, flush the eyes with cold water or eyewash solution and seek medical attention. If taken internally do not induce vomiting, seek immediate medical attention. Failure to follow these instructions may result in personal injury.



CAUTION: Make sure that the vehicle is standing on a level surface or supported on a wheel free lift.



CAUTION: If brake fluid comes into contact with the paintwork, the affected area must be immediately washed down with cold water.

NOTE:

The system consists of separate circuits for each front and diagonally opposite rear wheel. Each front to rear circuit and each wheel circuit can be bled individually of each other.

NOTE:

The service ABS hydraulic control unit is supplied pre-filled with brake fluid. Therefore, a conventional bleed procedure should be adequate to remove all the air from the brake system.

1.



CAUTION: Make sure that the brake master cylinder reservoir filler cap does not become contaminated.

Remove the brake master cylinder reservoir filler cap.

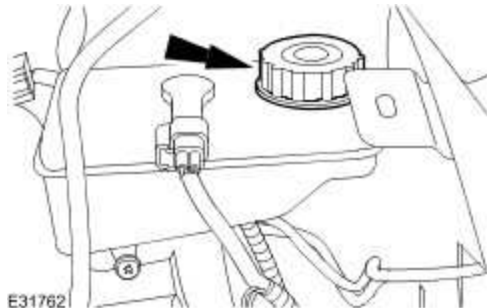

2. **NOTE:**

Always use fluid from a sealed container and dispose of used fluid safely.

Fill up the brake master cylinder reservoir to the MAX mark as necessary.

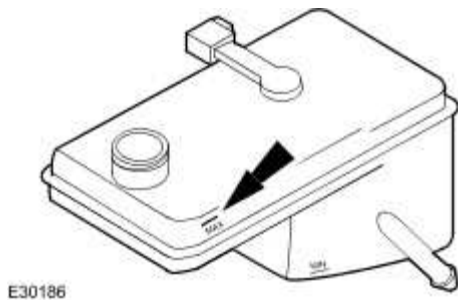

3. Install a bleed tube to the rear right-hand brake caliper bleed nipple.

4. Bleed the circuit.

- Make sure the bleed tube is firmly attached to the bleed nipple.
- Submerge the end of the bleed tube in a bleed jar containing a small quantity of approved brake fluid.
- Position the bleed jar base at least 300 mm (12 in) above the bleed nipple to maintain fluid pressure and prevent air leaking past the bleed nipple threads.
- Open the bleed nipple half a turn.
- Slowly apply the brake pedal to its maximum travel (this forces brake fluid into the bleed jar).
- Close the bleed nipple.
- Return the brake pedal to the rest position.
- Wait 2 seconds to allow the brake fluid to replenish the system.
- Fill up the brake master cylinder reservoir to the MAX mark as necessary.
- Continue to bleed the circuit until air-free brake fluid is pumped into the jar.
- Fully tighten the bleed nipple.

5. Repeat the procedure for the rear left, front right and front left-hand brake circuits.

6. Fill up the brake master cylinder reservoir to the MAX mark.

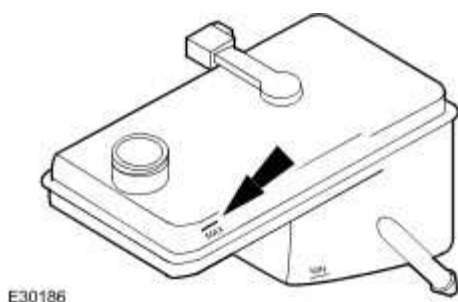

7. Install the brake master cylinder reservoir filler cap.

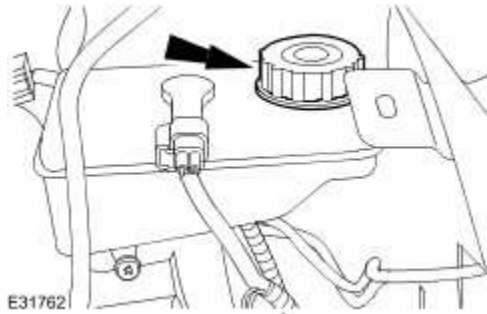

Additional Procedure to Bleed New Calipers with Integral Park Brake Mechanism

NOTE:

Due to the complexity of the fluid path within the integral park brake calipers, it may be difficult to achieve a satisfactory result using the procedure above when new calipers have been installed.

1. Using the Jaguar approved diagnostic system, put the park brake system into service mode.
2. Remove both rear wheels and tires. [<<204-04>>](#)
3. Bleed the braking system.
4. Disconnect the parking brake cable.
 - Release the tension.
 - Disconnect the park brake cable.

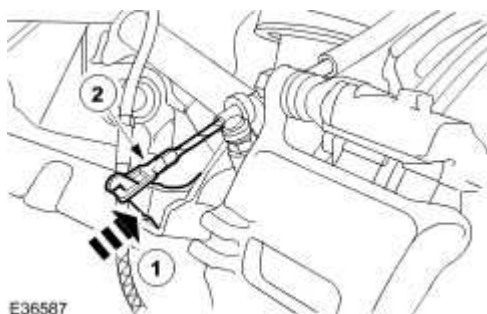

5. Detach the park brake cable.

1. Release the retaining tangs.
2. Detach the park brake cable.

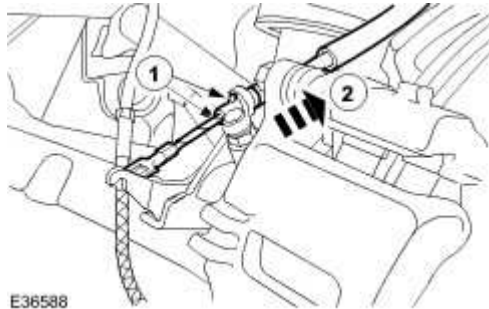

6. Detach the brake caliper from the anchor bracket.

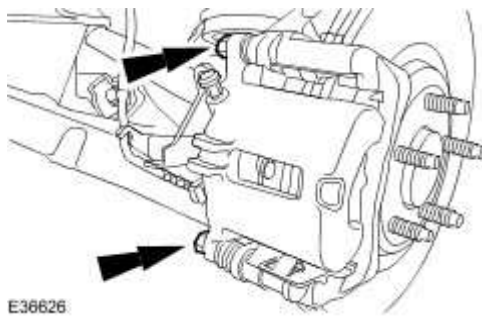

7. **NOTE:**

The inner brake pad must have at least 7mm of friction material. If there is less than 7mm a new pad must be used.

Remove the outer brake pad.

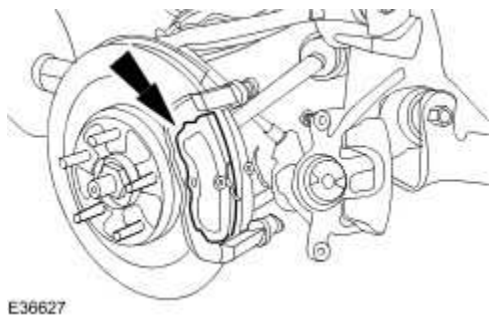

8. Attach the brake caliper with a protective cloth placed between the caliper fingers and the disc.

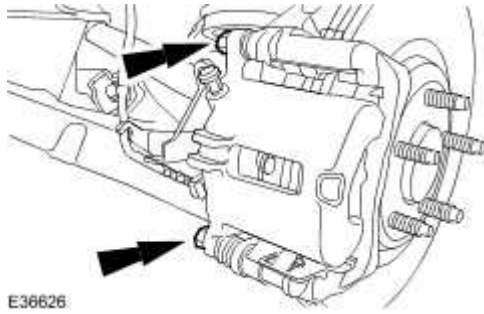

9. Slowly apply the brake pedal until the piston is extended to the brake disc.

10. Detach the brake caliper from the anchor bracket.

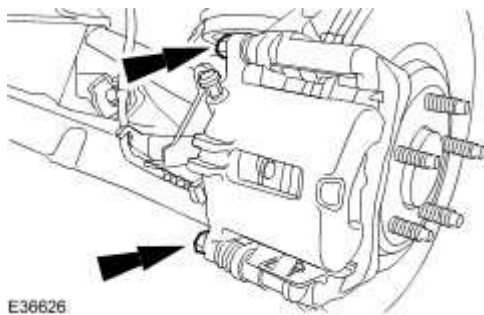

11. Bleed the caliper.

- Make sure the bleed tube is firmly attached to the bleed nipple.
- Submerge the end of the bleed tube in a bleed jar containing a small quantity of approved brake fluid.
- Position the bleed jar base at least 300 mm (12 in) above the bleed nipple to maintain fluid pressure and prevent air leaking past the bleed nipple threads.
- Position the brake caliper with the piston facing down and the bleed nipple at the top.
- Open the bleed nipple half a turn.
- Using the special tool, fully retract the caliper piston.
- Close the bleed nipple.
- Repeat the above procedure twice.
- Fill up the brake master cylinder reservoir to the MAX mark as necessary.
- Continue to bleed the caliper using the above procedure until air-free brake fluid is pumped into the jar.
- Fully tighten the bleed nipple.
- Make sure the piston grooves are aligned to fit the brake pad peg when the caliper is assembled.

12. Install the outer brake pad.

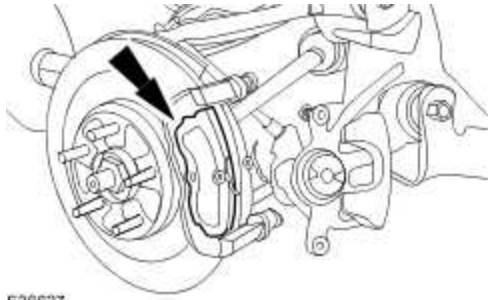

E36627

13. Install the brake caliper.

- Install new brake caliper guide pin retaining bolts.
- Tighten to 34 Nm.

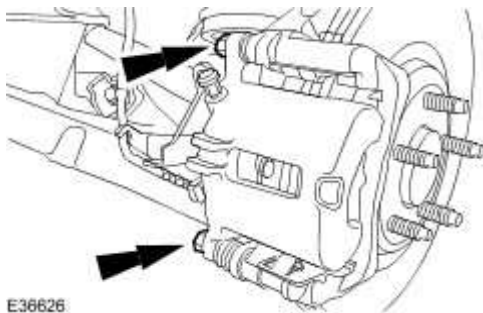

E36626

14. Attach the park brake cable.

- Attach the park brake cable.
- Fully seat the retaining tangs.

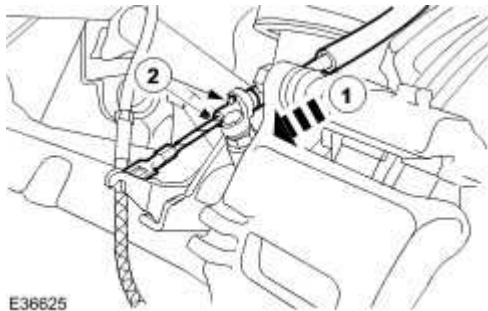

E36625

15. Connect the park brake cable.

- Release the tension.
- Connect the park brake cable.

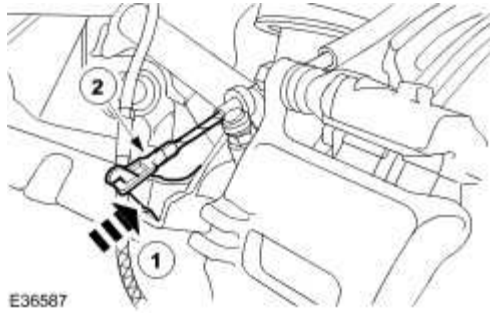

16. Bleed the braking system.

17. Install the wheels and tires. [<<204-04>>](#)