



Electrical Wiring Diagrams



XJ
(1a) VIN: V22231 >



BY APPOINTMENT TO
HER MAJESTY QUEEN ELIZABETH II
MANUFACTURERS OF DAIMLER AND JAGUAR CARS
JAGUAR CARS LIMITED COVENTRY



BY APPOINTMENT TO
HIS ROYAL HIGHNESS THE PRINCE OF WALES
MANUFACTURERS OF DAIMLER AND JAGUAR CARS
JAGUAR CARS LIMITED COVENTRY

Electrical Wiring Diagrams

XJ

(1a) VIN: V22231 >

Published by Technical Communications, Jaguar Cars Limited
Publication Part No. JLR 16 00 21_1E

PREFACE

While every effort is made to ensure accuracy, design changes to the vehicle may be made in the period between the completion of this publication and the introduction of vehicles.

All rights reserved. No part of this publication may be reproduced, stored in a retrieval system or transmitted in any form, electronic, mechanical, recording or other means without prior written permission from Jaguar Cars Limited.

Paper copies of this document are uncontrolled, always refer to the electronic source material for the latest information.

© 2011 Jaguar Cars Limited

ABBREVIATIONS

..... ix

USING THIS PUBLICATION

Health and safety x
Using this publication x
Section numbering x
Understanding the circuit diagrams xi

204-04 - WHEELS AND TIRES

Tire pressure monitoring system 1

204-05 - VEHICLE DYNAMIC SUSPENSION

Continuously variable damping (CVD) 2
Air suspension 3
Air suspension with CVD 4
Air suspension with CVD 5

205-02 - REAR DRIVE AXLE AND DIFFERENTIAL

Electronic rear differential 6

206-05 - PARKING BRAKE AND ACTUATION

..... 7

206-09 - ANTI-LOCK CONTROL

Dynamic stability control 8
Brake pad wear sensors 9

211-04 - STEERING COLUMN

Steering wheel 10
Steering Column Adjustment 11

303-03 - ENGINE COOLING

Petrol 12
Diesel 13

303-06 - STARTING SYSTEM

Block-heater 14
Petrol - LHD 15
Petrol - RHD 16
Diesel - LHD 17
Diesel - RHD 18

303-14A - ELECTRONIC ENGINE CONTROLS - PETROL

Vehicle interface 19
Sensors 20
Actuators 25
Emissions 29
Coolant pump - PV8SC 31

303-14B - ELECTRONIC ENGINE CONTROLS - DIESEL

Vehicle interface 32
Sensors 35
Actuators 39
Glow plugs 42
Emissions 43

307-01 - AUTOMATIC TRANSMISSION

Petrol 45
Diesel 46

310-01 - FUEL TANK AND FUEL LINES

Petrol 47
Diesel 48

310-03 - SPEED CONTROL

Petrol	50
Diesel	51
Adaptive	52

412-01 - CLIMATE CONTROL

Part 1	53
Part 2	54
Part 3	55
Part 4	56
Rear	57

412-02 - AUXILIARY CLIMATE CONTROL

.....	58
-------	----

413-01 - INSTRUMENT CLUSTER

.....	60
-------	----

413-13 - PARKING AID

Front	61
Rear	62
Rear view camera	63

414-01 - BATTERY, MOUNTING AND CABLES

Battery cables - Petrol	64
Battery cables - Diesel	65
Engine junction box	66
Central junction box	70
Rear junction box	87
Ground distribution	90

414-02 - GENERATOR AND REGULATOR

Charging - Petrol	98
Charging - Diesel	99

415-00 - INFORMATION AND ENTERTAINMENT SYSTEM

Part 1	100
Part 2	101
Part 3	102
10-Speaker system (LHD)	103
10-Speaker system (RHD)	104
12-Speaker system (LHD)	105
12-Speaker system (RHD)	106
15-Speaker system (LHD)	107
15-Speaker system (RHD)	108
Digital Audio Broadcasting (DAB)	109
Satellite Digital Audio Radio System (SDARS)	110
Television	111
Rear	112

417-01 - EXTERIOR LIGHTING

Headlamps	115
Headlamps - adaptive front lighting system	116
Side lamps	117
Fog lamps	118
Brake and reverse lamps	119
Turn signal indicators and hazard flashers	120
Turn signal repeaters	121

417-02 - INTERIOR LIGHTING

Map and Courtesy	122
Tread plate illumination	124
Doors and Luggage compartment	125
Ambient lighting - Front	126
Switch Illumination	127
Ambient lighting - Rear	129

418-00 - MODULE COMMUNICATIONS NETWORK

CAN bus - Medium speed - LHD	130
CAN bus - Medium speed - RHD	135
CAN bus - High speed	140
MOST	145

419-01 - ANTI-THEFT SYSTEM

Part 1	149
Part 2	150
Part 3	151
Passive start	152

419-07 - NAVIGATION SYSTEM

Asia	153
Japan	154

419-15 - ELECTRONIC FEATURES MODULES

Glove compartment release	155
---------------------------------	-----

501-09 - REAR VIEW MIRRORS

Electrochromic	156
Mirror Movement	157
Blind spot monitoring (LHD)	158
Blind spot monitoring (RHD)	159

501-10 - SEATING

Driver seat - 12 way memory (LHD)	160
Driver seat - 12 way memory (RHD)	161
Driver seat - 8 way memory (LHD)	162
Driver seat - 8 way memory (RHD)	163
Driver seat - Lumbar and bolster control	164
Driver seat - 2 way lumbar only	165
Passenger seat - 12 way memory (LHD)	166
Passenger seat - 12 way memory (RHD)	167
Passenger seat - 8 and 12 way (LHD)	168
Passenger seat - 8 and 12 way (RHD)	169
Passenger seat - 2 and 4 way lumbar and bolster control	170
Passenger seat - 2 way lumbar and bolster control	171
Passenger seat - 2 way lumbar only	172
Heated - front	173
Climate controlled - Front (LHD)	174
Climate controlled - Front (RHD)	175
Climate controlled - Rear (stationary)	176
Climate controlled - Rear (moveable)	177
Heated - rear	178
Massage - Driver	179
Massage - Passenger	180
Massage - Common	181
Rear - Left hand	182
Rear - Right hand	183
Rear Massage - Common	184

501-11 - GLASS, FRAMES AND MECHANISMS

Window lift - front	185
Window lift - rear	186
Rear sunblind	187

501-12 - INSTRUMENT PANEL AND CONSOLE

Switch pack - Instrument panel (center)	188
Switch pack - Instrument panel (center)	189
Accessory socket(s)	190

501-14 - HANDLES, LOCKS, LATCHES AND ENTRY SYSTEMS

Keyless entry - Front (LHD)	191
Keyless entry - Front (RHD)	192
Keyless entry - Rear	193
Front dead locks	194
Rear dead locks	195
Fuel flap	196
Luggage compartment lid release - Part 1	197
Luggage compartment lid release - Part 2	198

501-16 - WIPERS AND WASHERS

Part 1	199
Part 2	200

501-17 - ROOF OPENING PANEL

Roof opening panel and roof blinds	201
--	-----

501-20A - SAFETY BELT SYSTEM

.....	202
Retractors	203
Occupancy sensing	204

501-20B - SUPPLEMENTAL RESTRAINT SYSTEM

LHD	205
RHD	206

501-20C - PEDESTRIAN PROTECTION SYSTEM

.....	207
-------	-----

Abbreviation	Description
ABS	Anti-lock braking system
ADRC	Adaptive damping
AFS	Adaptive front lighting system
AMP	Audio amplifier
AUTO	Automatic transmission
AUU	Portable audio interface
BSM	Blind spot monitoring
CAN	Controller area network
CVD	Continuously variable damping
DAB	Digital audio broadcasting
DSC	Dynamic stability control
D4	Diesel engine - Straight-four
DPF	Diesel particulate filter
DV6	Diesel engine - V6
DV8	Diesel engine - V8
EGR	Exhaust gas recirculation
EMS	Engine management system
ETS	Electronic transmission shift
FET	Field effect transistor
GPS	Global positioning system
HID	High intensity discharge
HS CAN	High speed controller area network bus
IC	Instrument cluster
IMT	Intake manifold tuning
IP	Instrument panel
OCS	occupancy classification sensor
PV6	Petrol engine - V6
PV8	Petrol engine - V8
PV8NA	Naturally aspirated engine - V8
PV8SC	Super charged engine - V8
LH	Left-hand
LIN	Local interconnect network
MAF/IAT	Mass air flow / intake air temperature
MS CAN	Medium speed controller area network bus
MMM	Navigation system module
N/A	Normally aspirated
NAS	North American specification
PDC	Park distance control
RF	Radio frequency
RH	Right-hand
SAI	Secondary air injection
SCL	Steering column locking
SDARS	Satellite digital audio receiver system
TPMS	Tire pressure monitoring system
TSD	Touch screen display
TV	Television
ULEV	Ultra low emission vehicle
USB	Universal serial bus
VICS	Vehicle information control system

Health and safety

Always follow health and safety guidelines, specifically those detailed in the Workshop Manual.

Using this publication

The information provided in this publication is for use only by competent, qualified auto-electricians. Good product knowledge is assumed, as well as the ability to access and use recommended test equipment and other reference material provided.

Test equipment and other reference material

The information in this publication should be used in conjunction with the recommended test equipment; refer to Workshop Manual. Other reference material includes: Technical Service Bulletins (TSB) and the Workshop Manual.

The Electrical Reference Library (ERL) may also prove useful since it provides detailed connector information.

Battery disconnection and reconnection

It is imperative that any information relating to battery disconnection and reconnection is followed; refer to the appropriate sections in the Workshop Manual.

Fault Diagnosis

Always use the recommended test equipment for correct and reliable fault diagnosis, refer to the Workshop Manual.

Harness Repair

Repairs should only be undertaken for connectors where a Service Repair Kit is available; refer to the appropriate Electrical Reference Library (ERL).

Note: Fibre Optic circuits cannot be repaired; refer to the Workshop Manual.

Engine Harness In-line Connector Designations

It has been necessary to draw certain wiring diagrams to support and permit the sharing of common electrical harnesses, as a result the in-line connectors linking the engine compartment harness and the engine harness appear on separate pages.

In addition, it should be noted that the connector designations may not match; where this is the case, the matching connector designations are identified at the bottom right-hand side of the drawing, for example C11-P = C11-A. An arrow or a diamond is used to highlight the connectors that are affected by this convention.

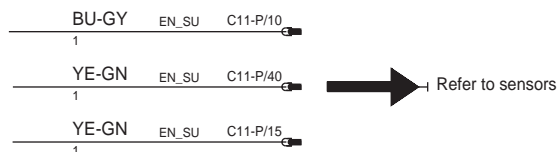

C11-P = C11-A
C11-N = C11-B
C11-M = C11-C

Section numbering

The sections in this publication are ordered to match the Global Outline numbering system as found in the current Workshop Manual. The Power and Ground distribution circuits can be found under section 414-01, BATTERY, MOUNTING AND CABLES.

Note: Where circuit diagrams show more than one sub-system, the circuit will be located in the section that carries the first-named sub-system, for example: Starting and Charging will be located under section 303-06 Starting System, since 'Starting' is the first-named sub-system.

USING THIS PUBLICATION

Understanding the circuit diagrams

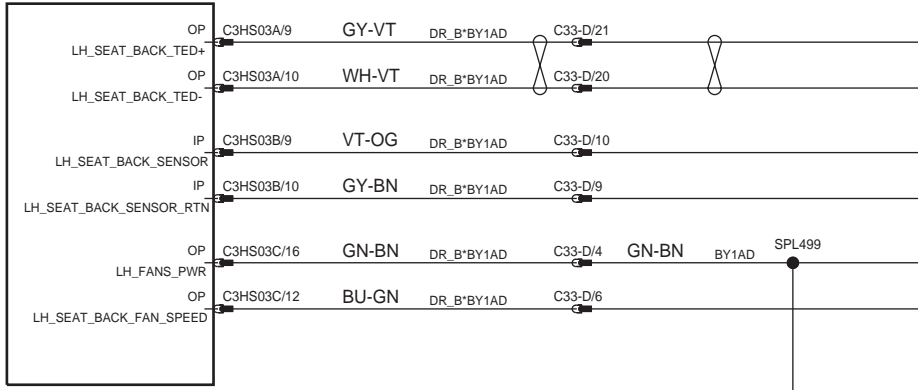

Connectors, Ground and Splices

Harnesses for the vehicle originate from a variety of different sources and therefore the connector nomenclature is inconsistent.

Wire Length

Wire length (where stated) is in millimeters and appear directly below the color code for each wire. Wire length values are displayed for LHD vehicles only, values for RHD vehicles may vary.

Twisted Wires

The 'figure-of-eight' symbol indicates that wires are twisted together.

By-pass Wires

Vehicles are customized to suit market or customer selected options. To reduce the number of circuits drawn, by-pass wires are shown. By-pass wires are identified by large, upper case letters designed to correspond with the alternative connection arrangement; refer to figure below.

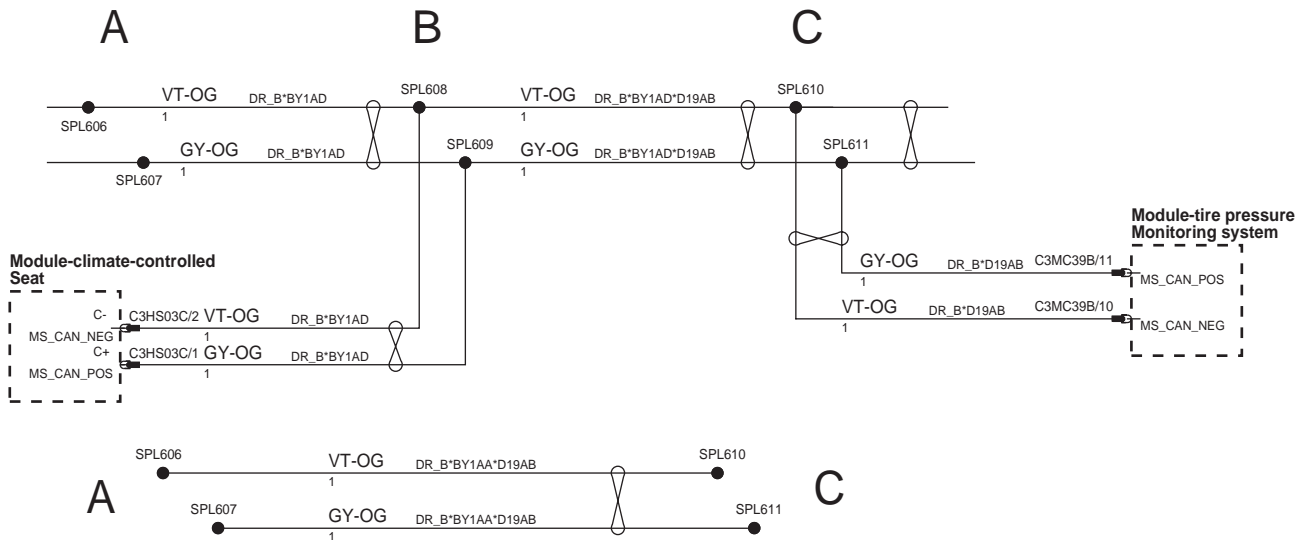

Connector Designation

Certain connectors have been drawn for harness manufacturing purposes only. In Example 1, the left-hand connector is always used, the connector drawn to the right-hand side of the dotted line is a dummy connector which should be ignored; refer to Service Interpretation 1.

Example 1:

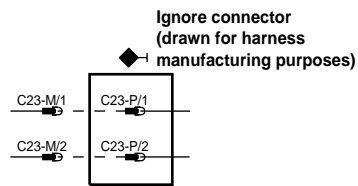

Service Interpretation 1:



Example 2 depicts that some pairs of connectors have also been drawn for harness manufacturing purposes, these connectors do not appear in the vehicle and therefore should be ignored; refer to Service Interpretation 2.

Example 2:

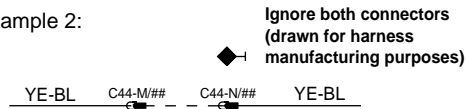

Service Interpretation 2:

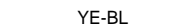

Control Module Pins

B+	Battery voltage
C-	CAN negative
C+	CAN positive
D	Data
GND	Ground
GREF	Sensor / signal ground **
IP	Input signal
LIN	Local interconnect network
MOST_RX	MOST receive
MOST_TX	MOST transmit
NEG	Negative
OP	Output signal
P	Power ground
POS	Positive
PWR	Power
SW	Switch
VBATT	Battery voltage
VREF	Sensor / signal supply V *

*May also indicate Reference Voltage.

**May also indicate Reference Ground or Logic Ground.

Wire Codes

CODE	COLOR
BK or B	BLACK
BN or N	BROWN
BU or U	BLUE
GN or G	GREEN
GY or S	GREY
OG or O	ORANGE
OPT	FIBER OPTIC
PK or K	PINK
RD or R	RED
SCR	SCREEN BRAID
VT or P	PURPLE
WH or W	WHITE
YE or Y	YELLOW

USING THIS PUBLICATION

Option Code

A code identifying an optional wiring arrangement, for example BY1AD, may be allocated to certain wires; refer to the Option Code Table.

The asterisk (*) represents 'and'; the colon (:) represents 'or'; for example:

DR_B*BY1AD, represents: left-hand drive AND heated & cooled seats

IBYAD*IESAB:IBYAC*IESAB, represents: satellite digital audio AND television OR digital audio AND television.

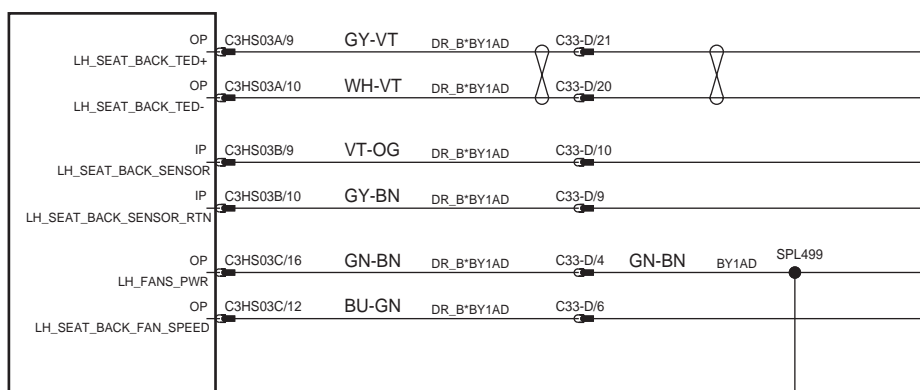

Option Code Table

Cct	Vehicle Option or Feature
2W_LUM	2 way lumbar
4W_LUM	4 way lumbar
A3RAB	deployable bonnet
A4EAC	passenger non memory
A4EAF	passenger memory
B3MAA	less windshield defrost
B3MAB	heated front screen
BS_FL	long wheel base
BSBAF	electrochromic interior mirror
BSHDF	fold back mirrors
BY1AB	driver heated seat
BY1AD	heated & cooled seats
BY3AB	heated seats
BY3AD	rear heated and cooled seats
BYPAM	10way driver seat movement
BYPAN	16way driver seat movement
BYPAW	20way driver seat movement
BYQAN	16way passenger seat movement
BYQAP	8way passenger seat movement
BYQAR	4way passenger seat movement
CBAAD	power dead locks
CBGAG	keyless entry
CBGAJ	without keyless entry
CFKAB	headlamp washer
CPQAB	front passenger airbag deactivation
CPQAC	OCS
CPXAB	no safety belt retract
CPXAC	safety belt retract
D19AB	TPMS
DR_B	LHD
DR_D	RHD
DRV	driver
DWABK	chassis control module
DWABN	air suspension
DWMAC	continuously variable damping
EGJAE	no electronic rear differential
EGJAL	electronic rear differential

USING THIS PUBLICATION

Cct	Vehicle Option or Feature
EM_N	ULEV 2 requirements
EN_RX	5.0L PV8NA engine
EN_RY	5.0L PV8SC engine
EN_SU	3.0 DV6 engine
EN_WD	3.0 PV6 engine
G1DAA	without smog sensor
G1DAB	smog sensor
G3AAJ	rear solar sensor
GRBAB	steering column lock
GTBAB	heated steering wheel
GTDAB	speed control
GTDAD	adaptive stop/go speed control
HKCAB	navigation
HLLAA	without blindspot monitoring
HLLAC	blindspot monitoring
HNHAB	battery backed security siren
HNHAC	passive sounder
HNLAB	front parking aid
IBYAC	digital audio
IBYAD	satellite digital audio
IDAAU	base audio system - 450 W
IDAAV	hi line premium
IDAAX	premium ice
IENAD	rear seat entertainment
IESAB	television
J3CAB	smokers package
J3KAA	less camera
J3KAB	park aid camera
JAPAN	Japanese market
JBBBA	HID headlamps
JBBBB	adaptive front lighting
LHS	left-hand side
NO_DAB	without digital audio broadcasting
NO_OCS	without occupancy classification sensor
NO_SDARS	without SDARS
PAS	passenger
RHS	right-hand side
W-FIRE	wireless headphone system

USING THIS PUBLICATION

Component Depictions

Example:



1.



2.

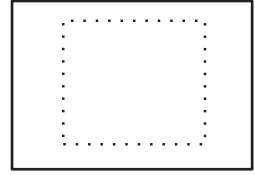

3.

1. Complete Components and Control Modules
2. Incomplete Components
3. Components with Internal Electronic Components

phcw93-70267-a-a3

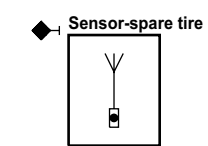
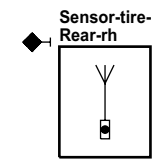
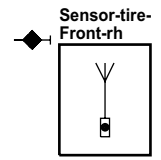
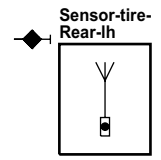
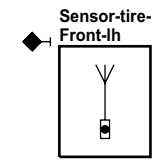
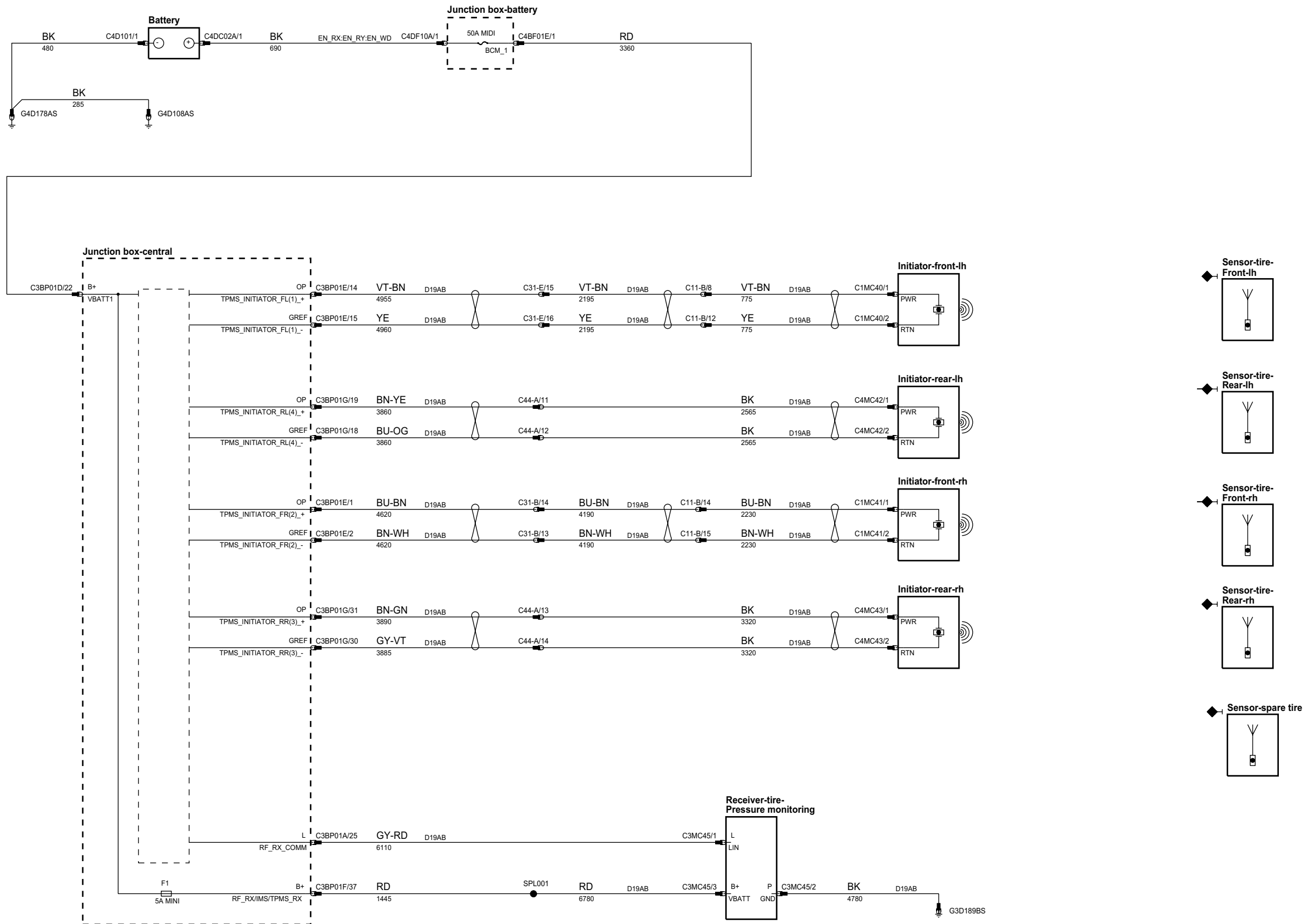

phcw93-70180-a-a3

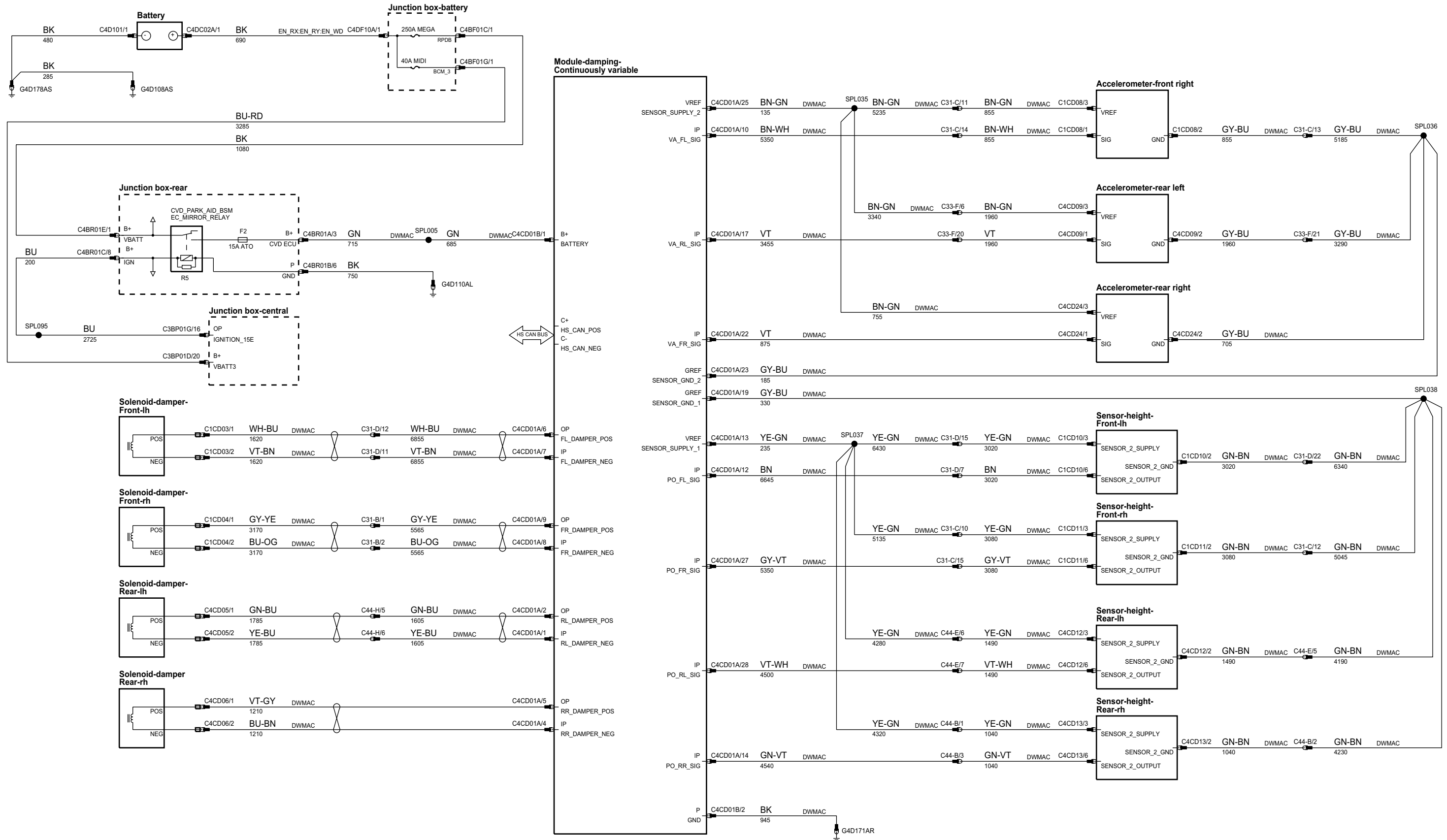

phcw93-70181-a-a3

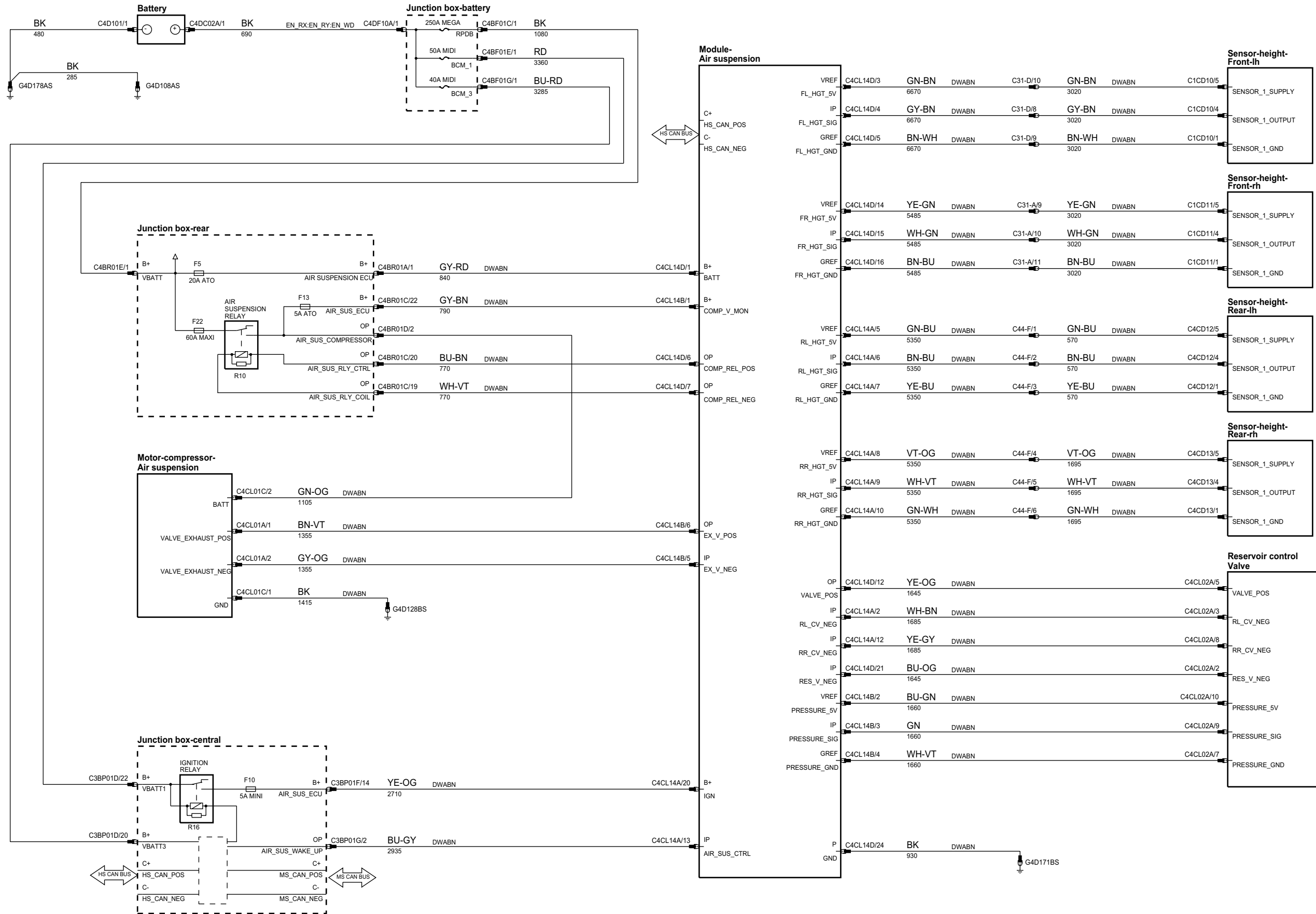

phcw93-70181-b-a3

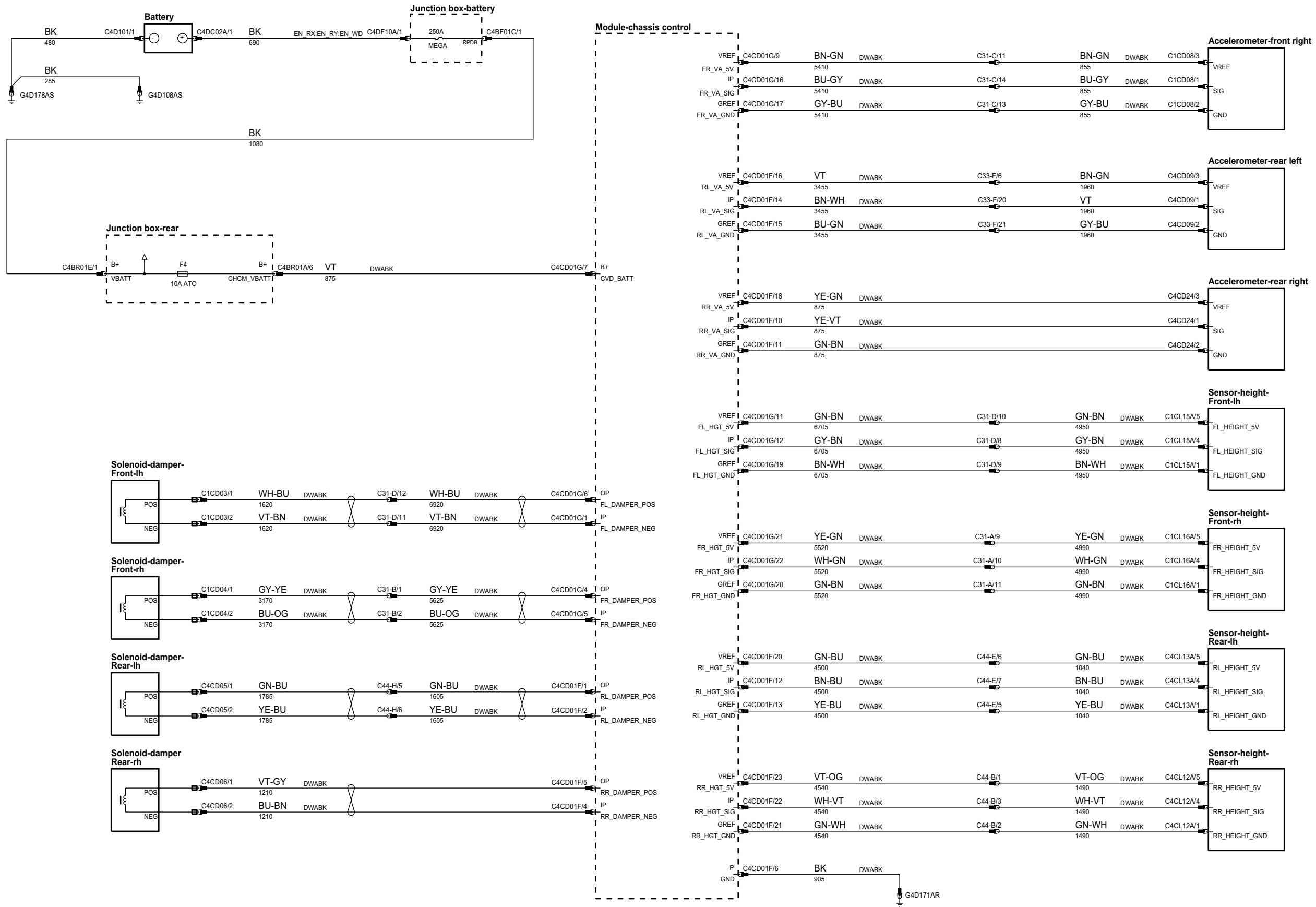

phcw93-70181-c-a3

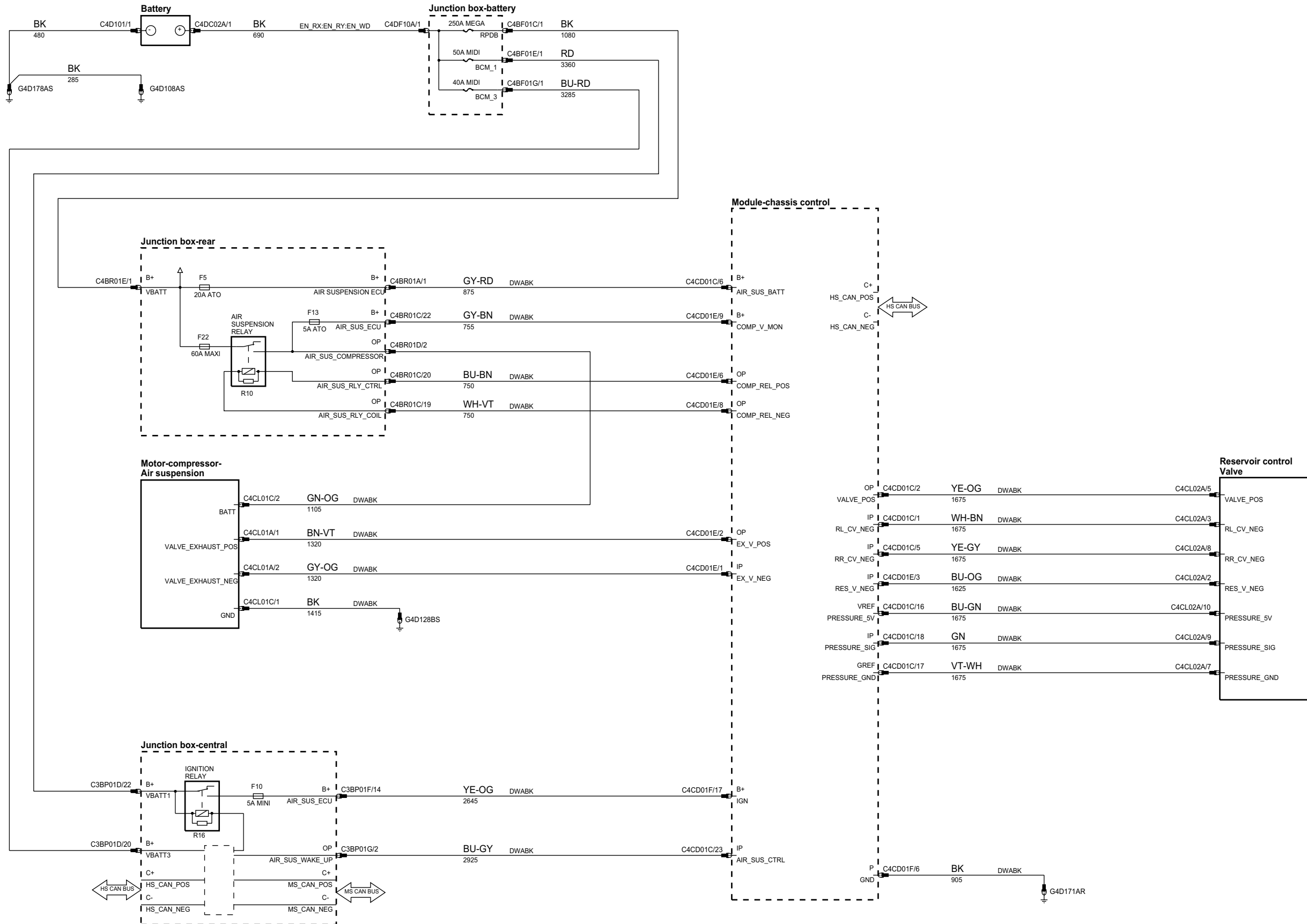

phcw93-70046-a-a3

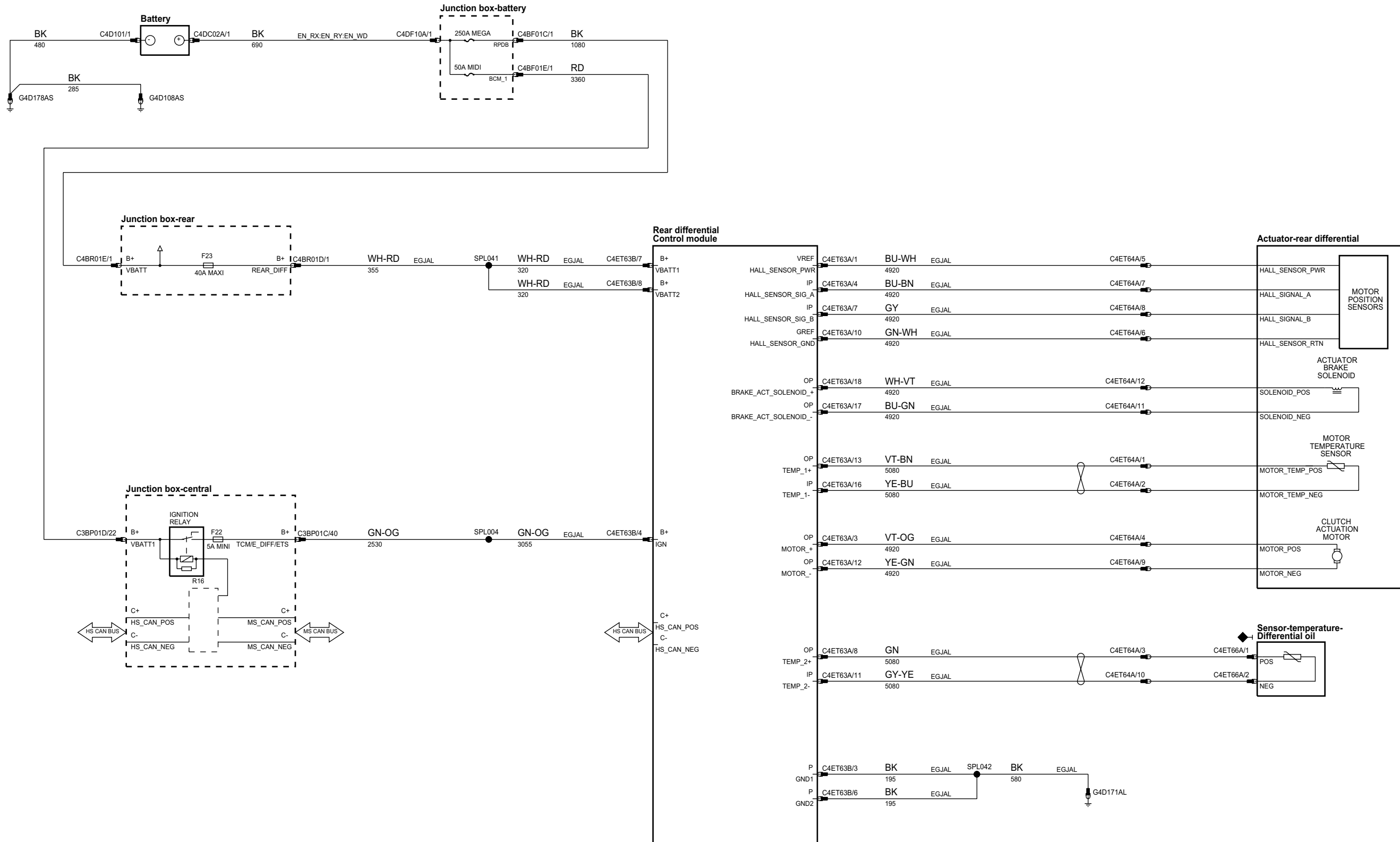

206-05 - PARKING BRAKE AND ACTUATION

phcw93-70167-a-a3

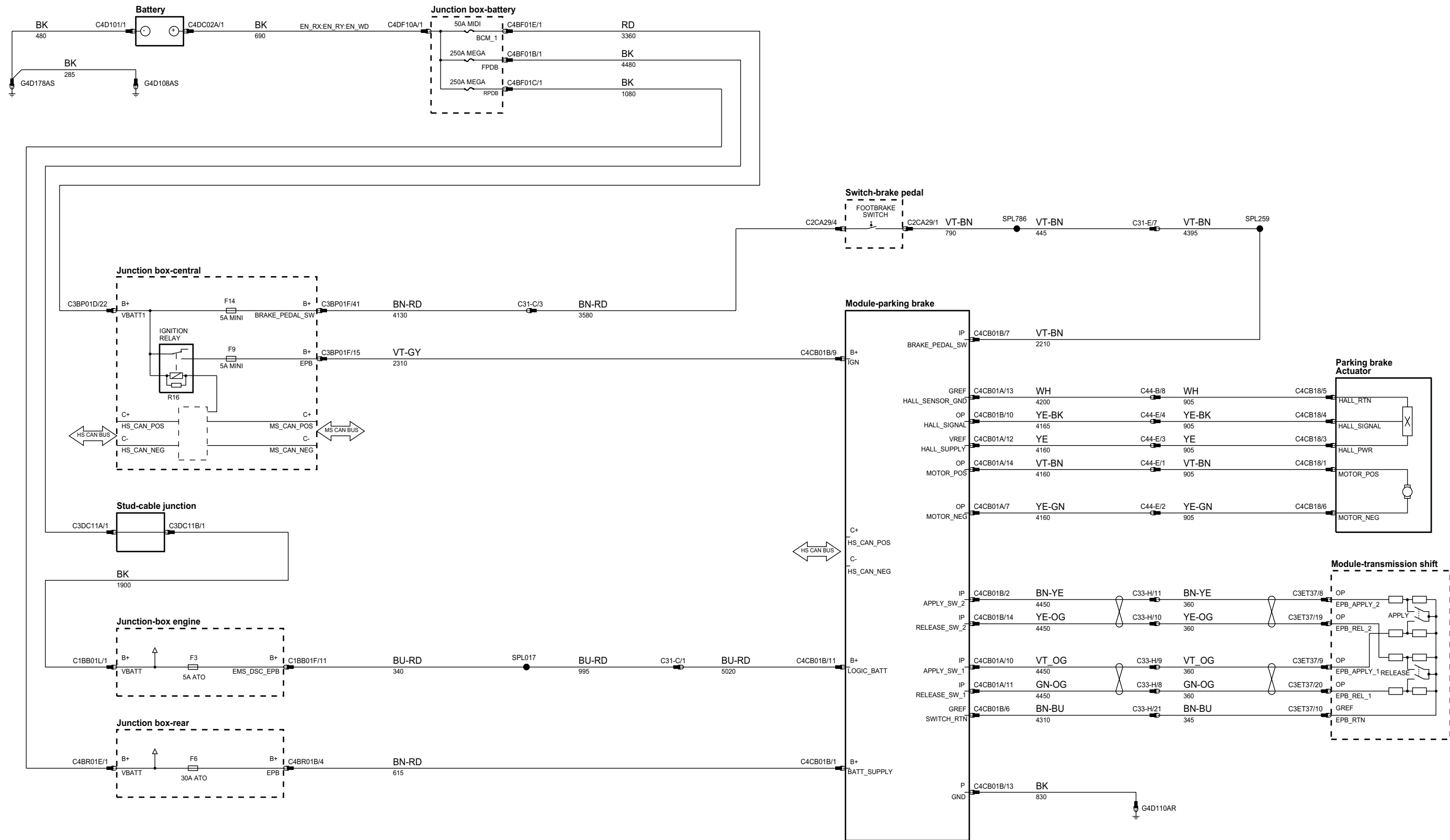

phcw93-70165-a-a3

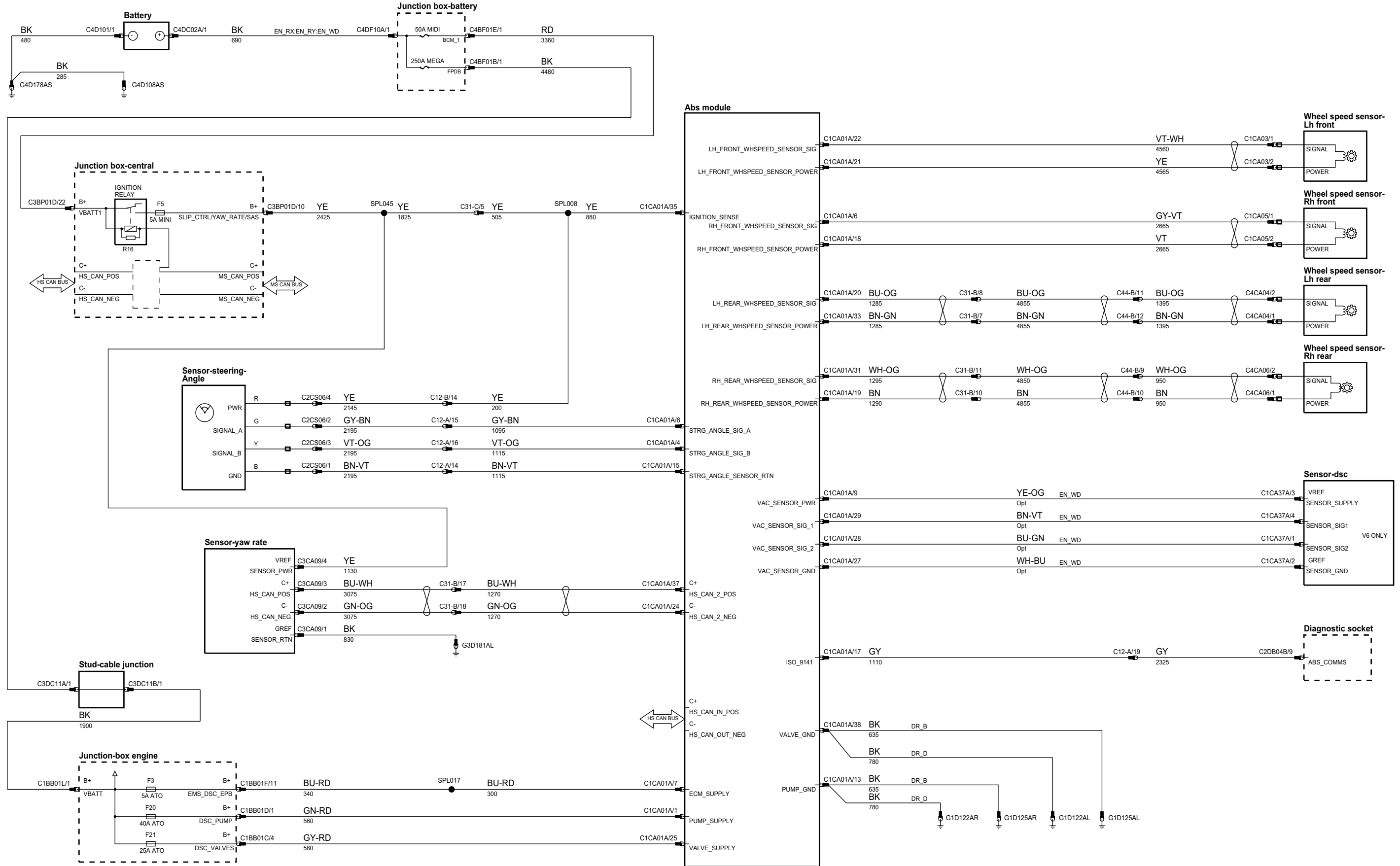

phcw93-70165-b-a3

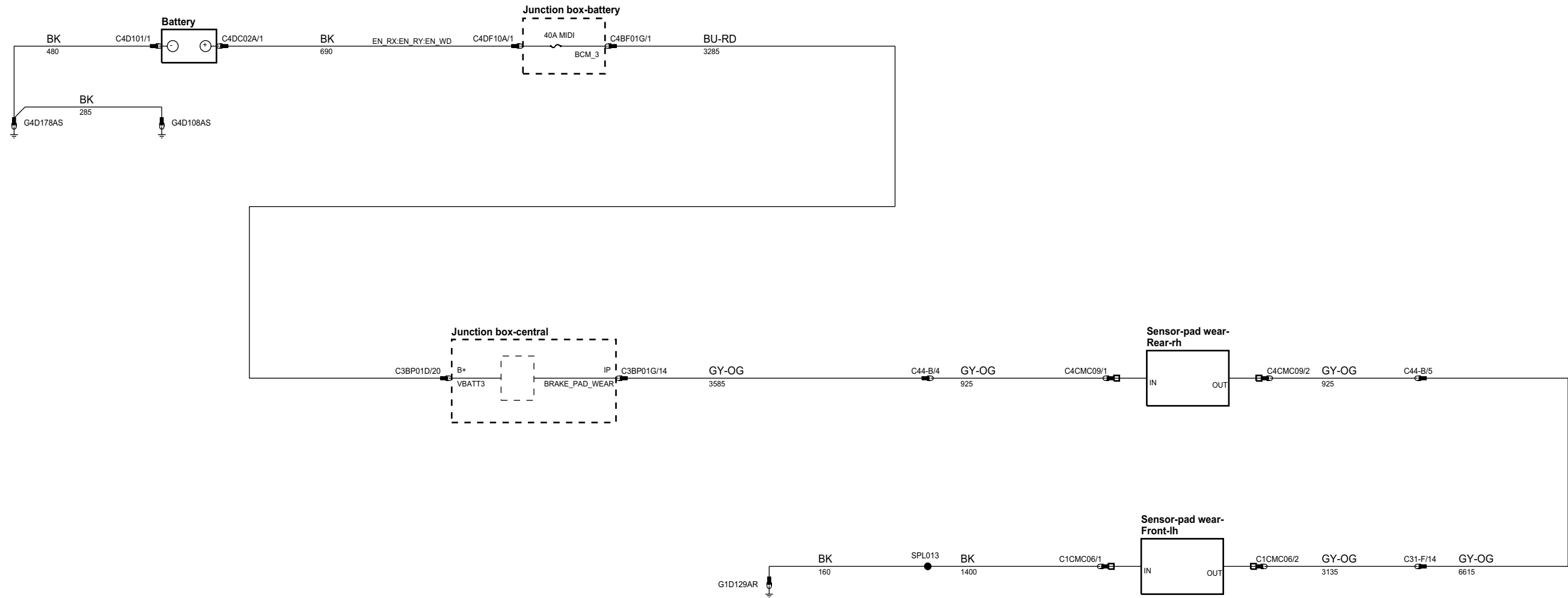

phcw93-70170-a-a3

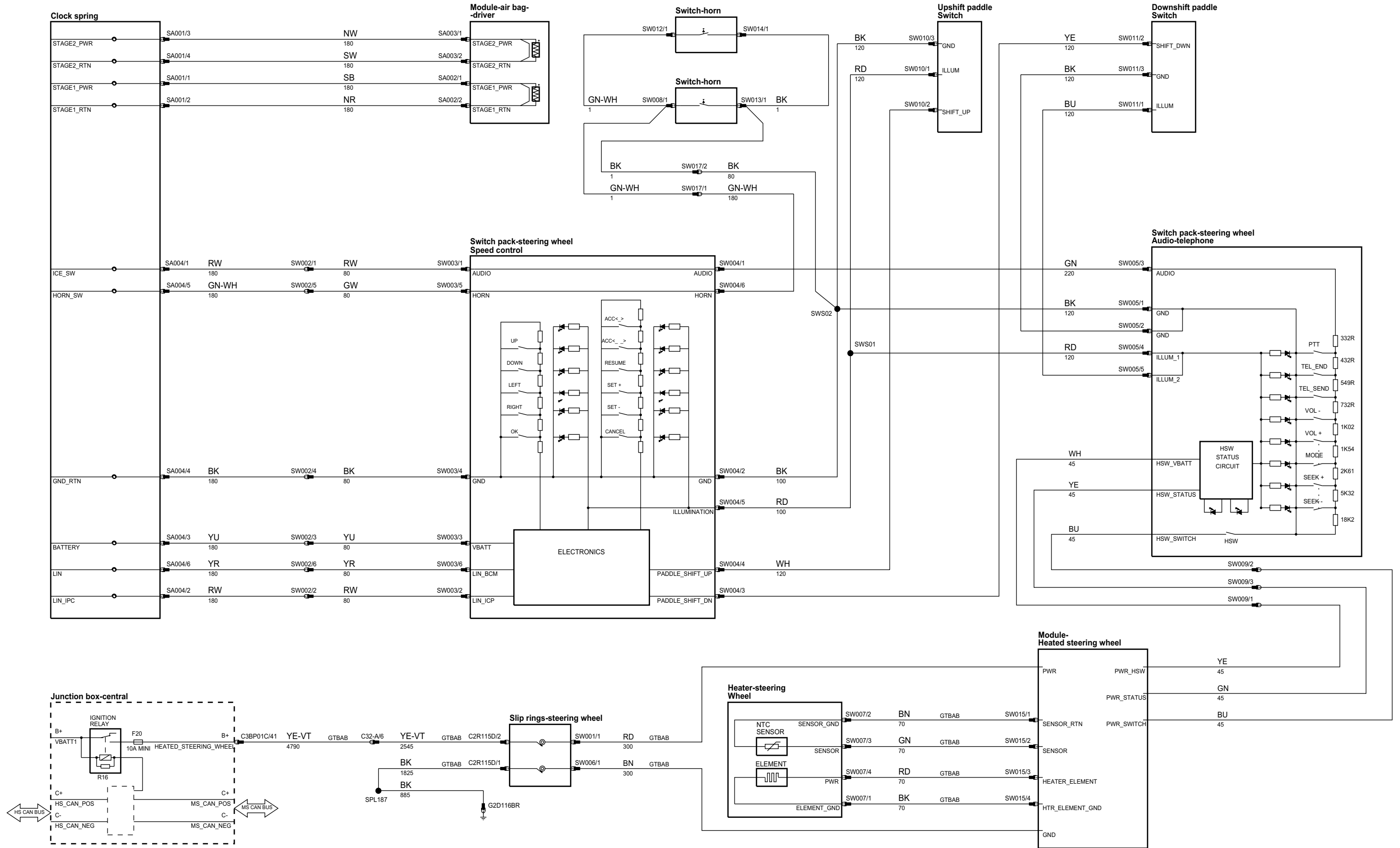

phcw93-70360-a-a3

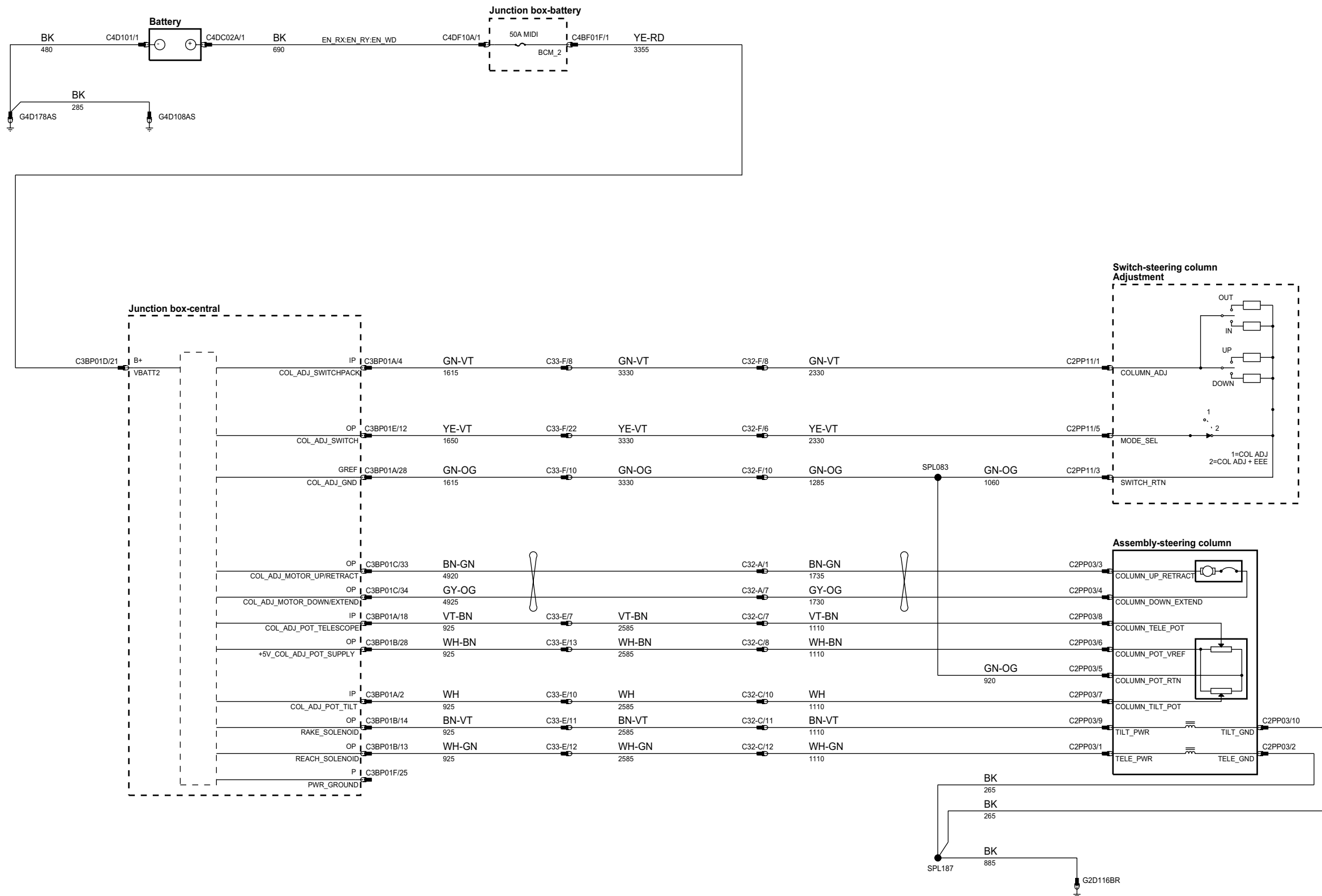

phcw93-70033-a-a3

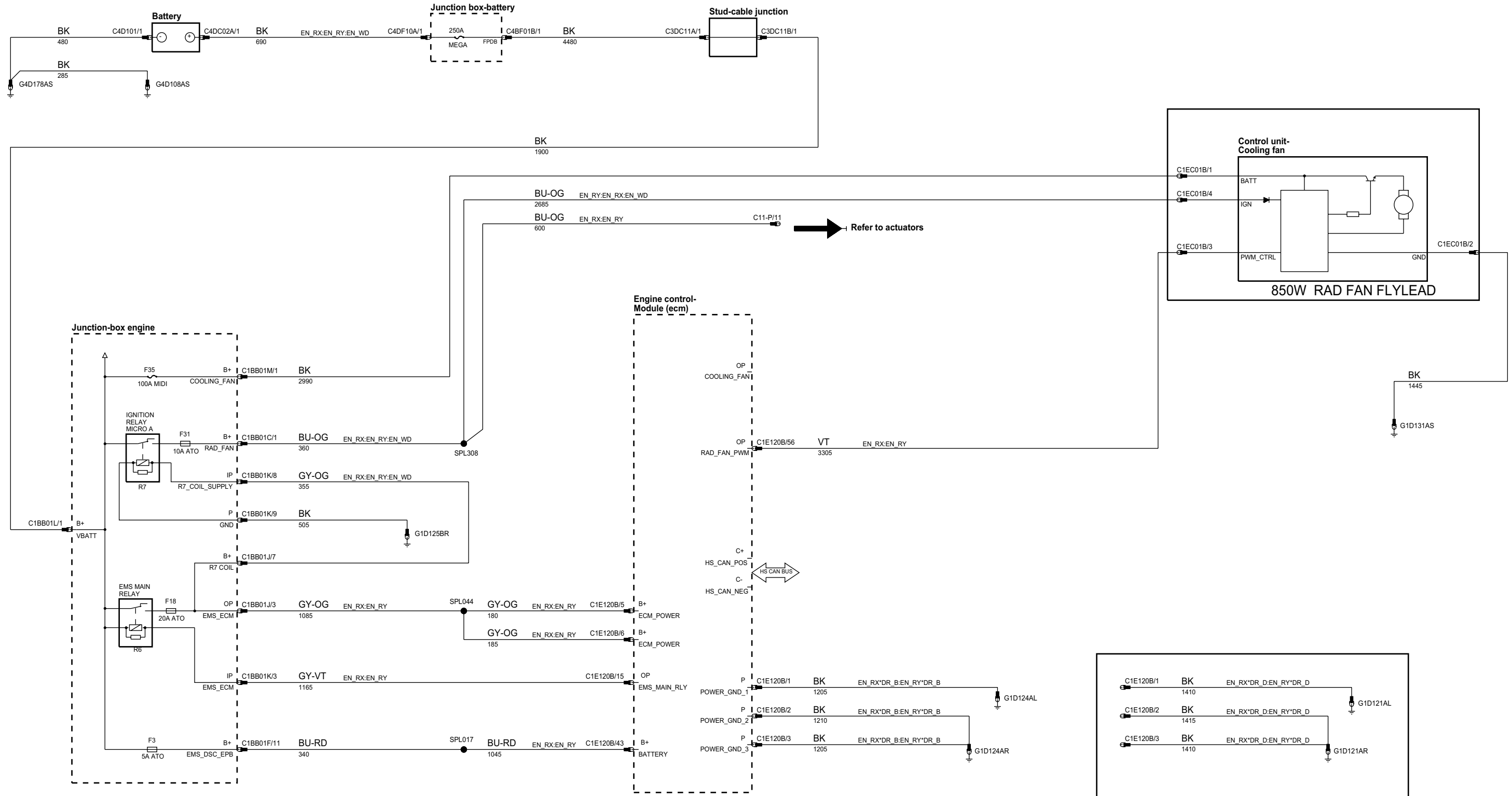

phcw93-70033-d-a3

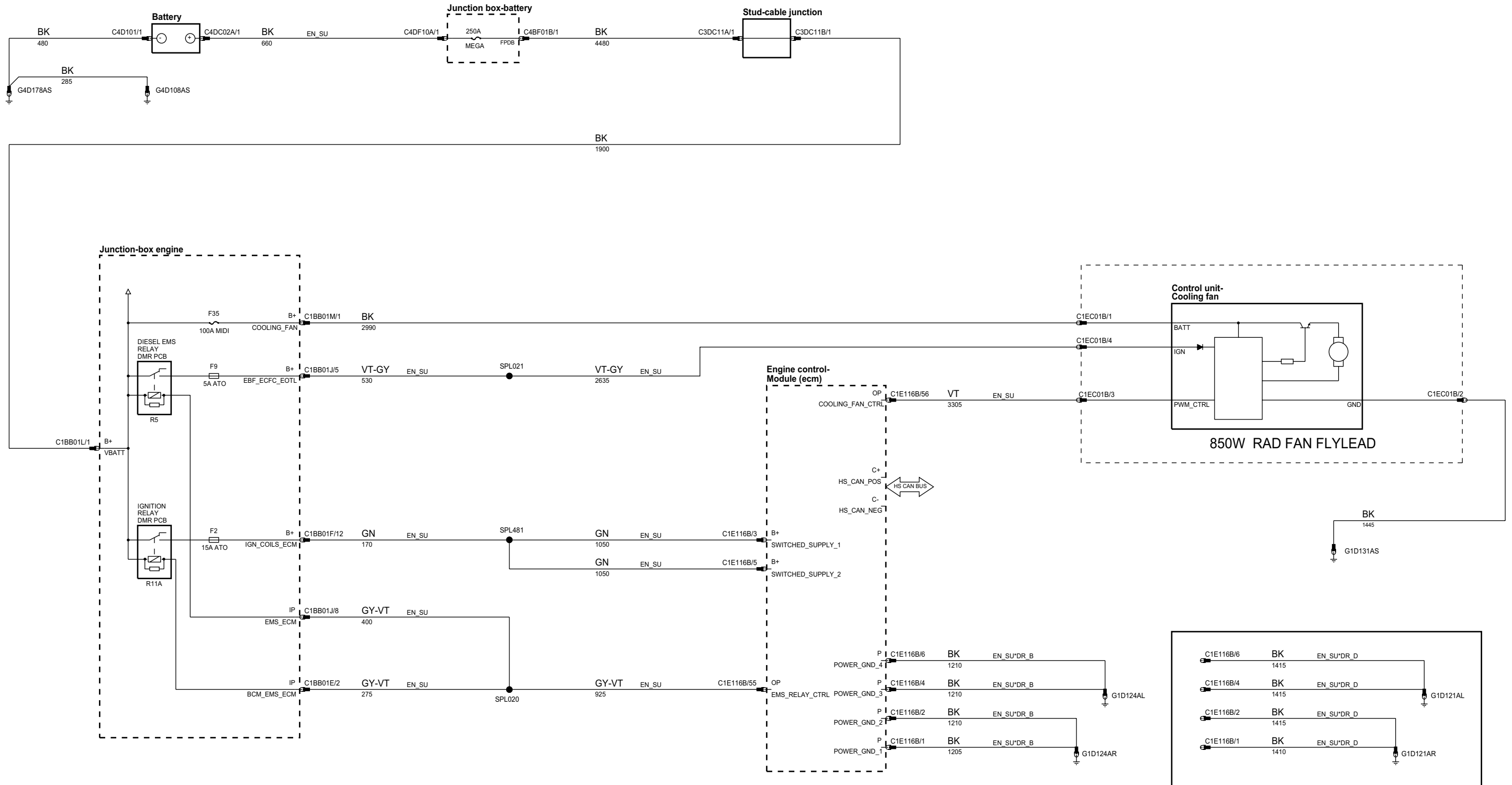

phw93-70365-b-a3

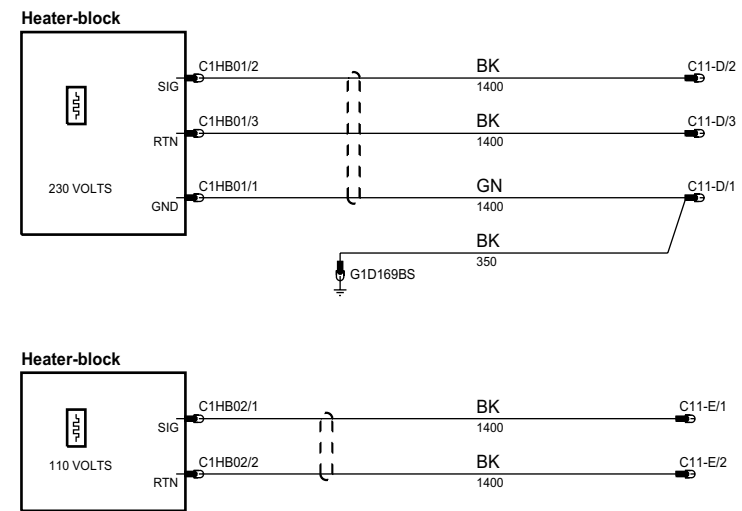

phcw93-70021-a-a3

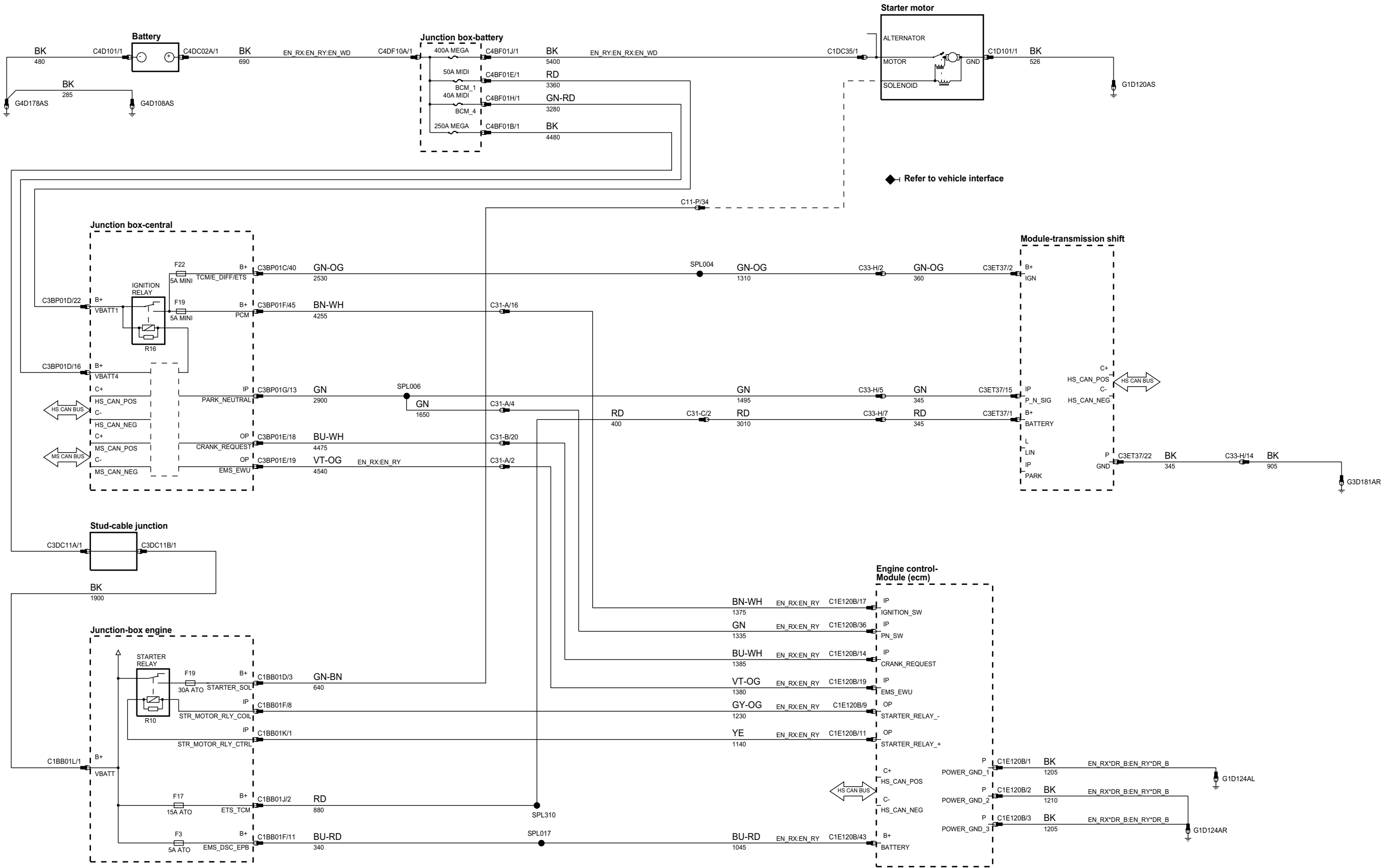

phcw93-70021-e-a3

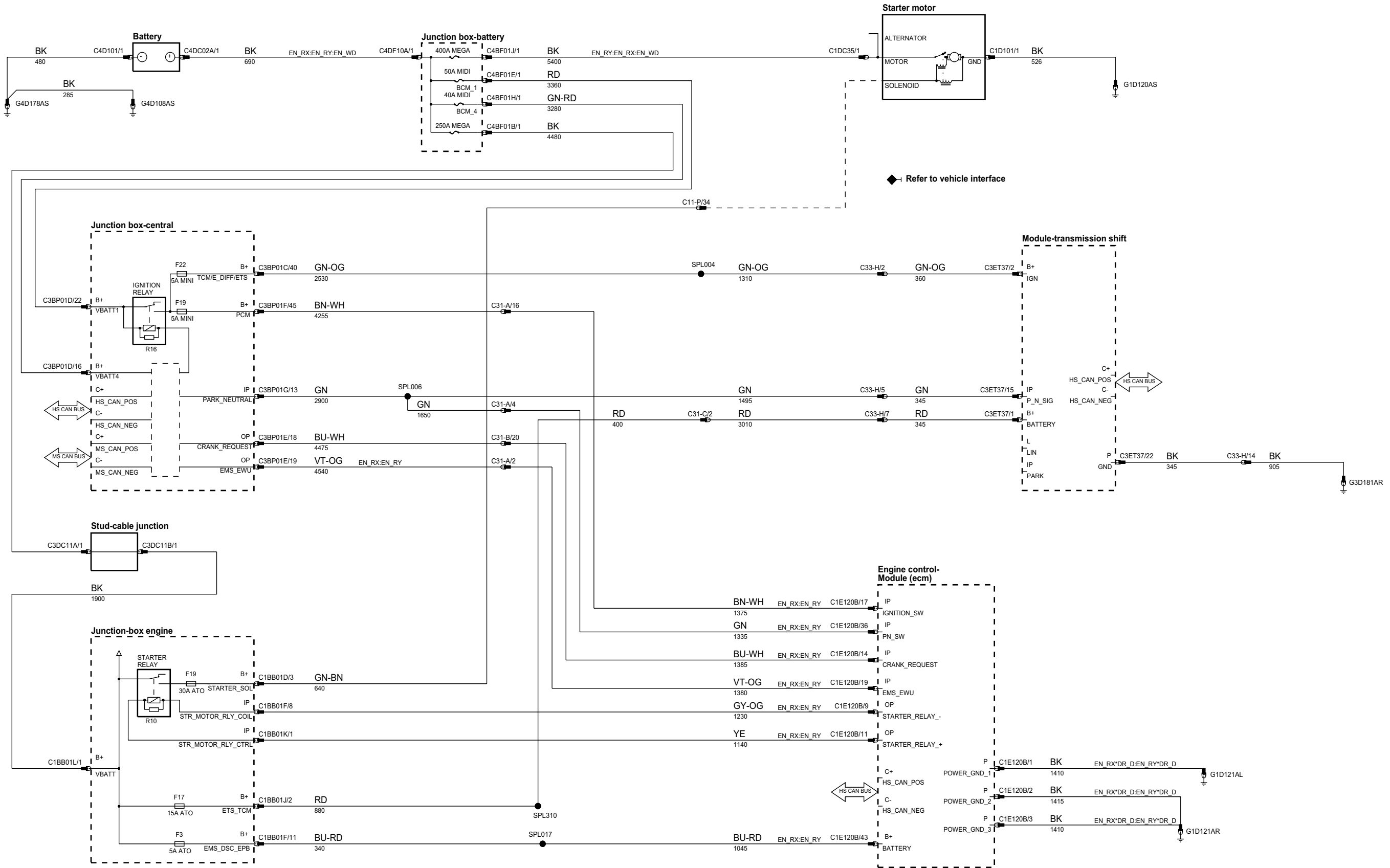

phcw93-70021-d-a3

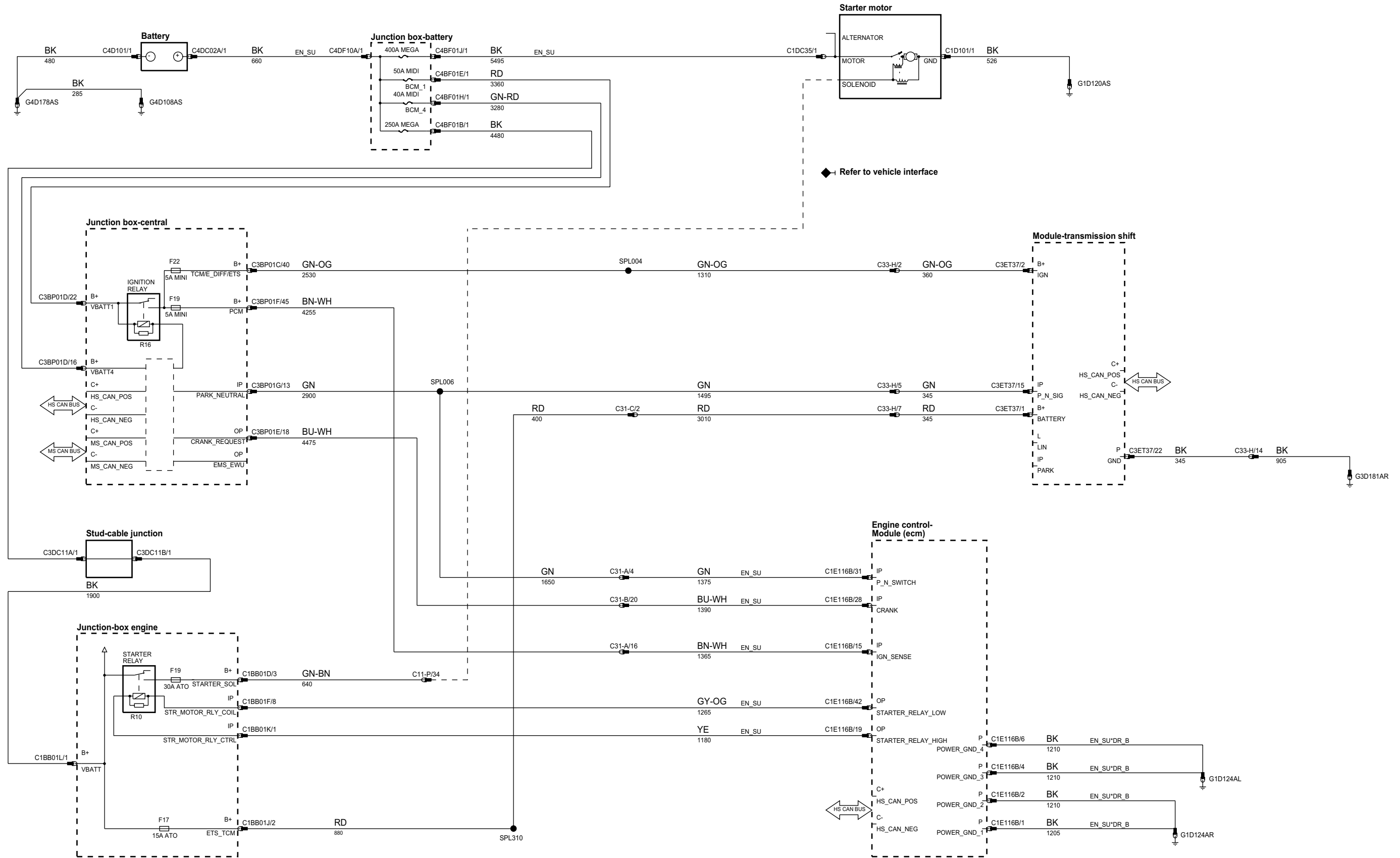

phcw93-70021-d2-a3

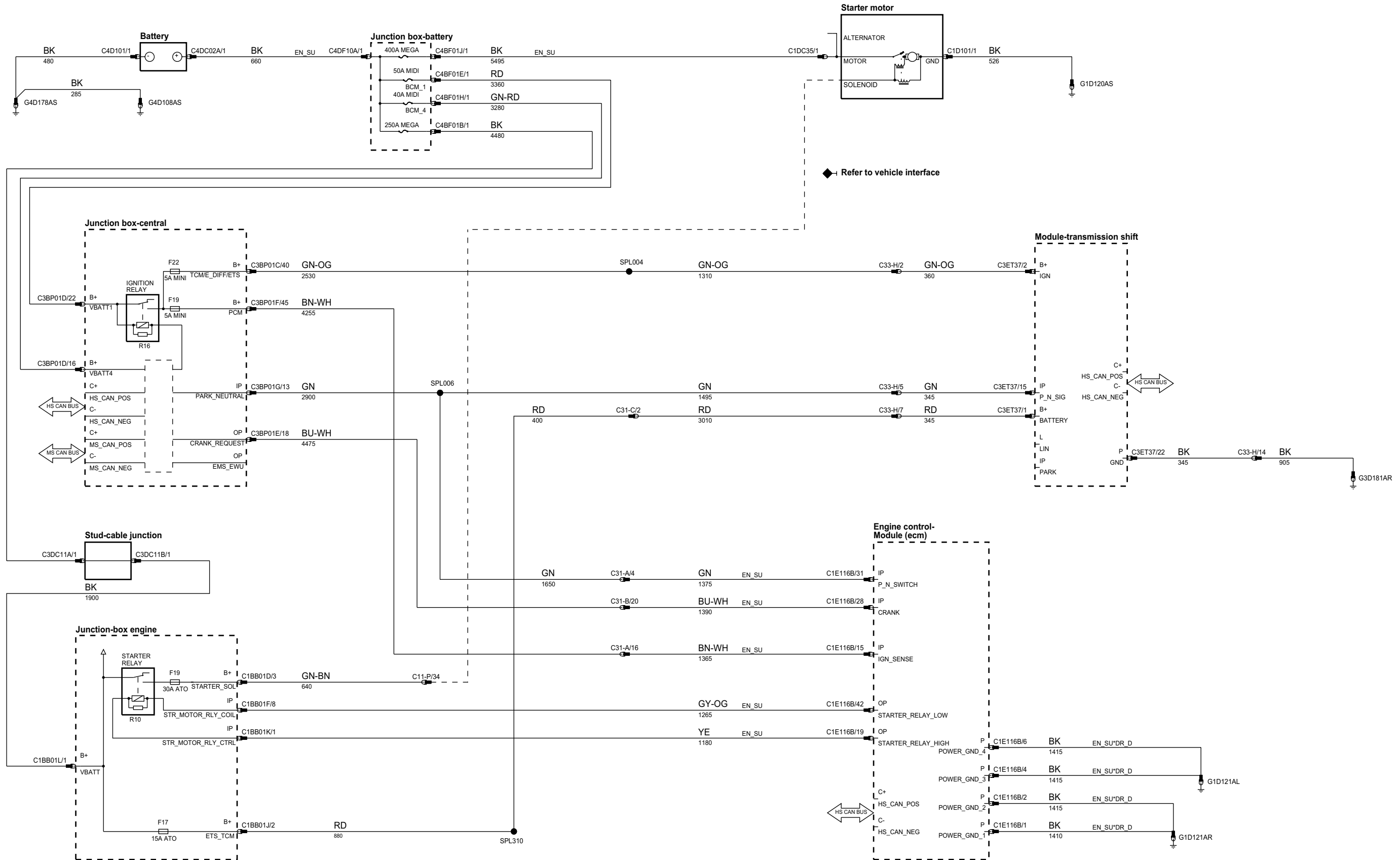

pha133-70031-a-a5

**Air conditioning (a/c)
Compressor solenoid**

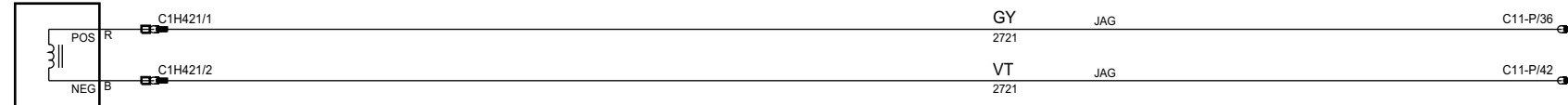

← Refer to climate control

Starter motor

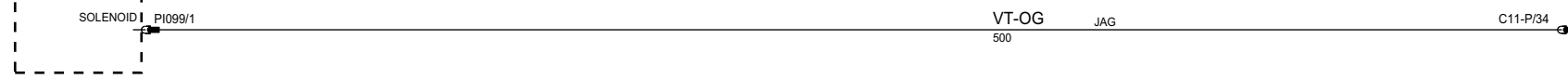

← Refer to engine junction box

**Transmission control
Module**

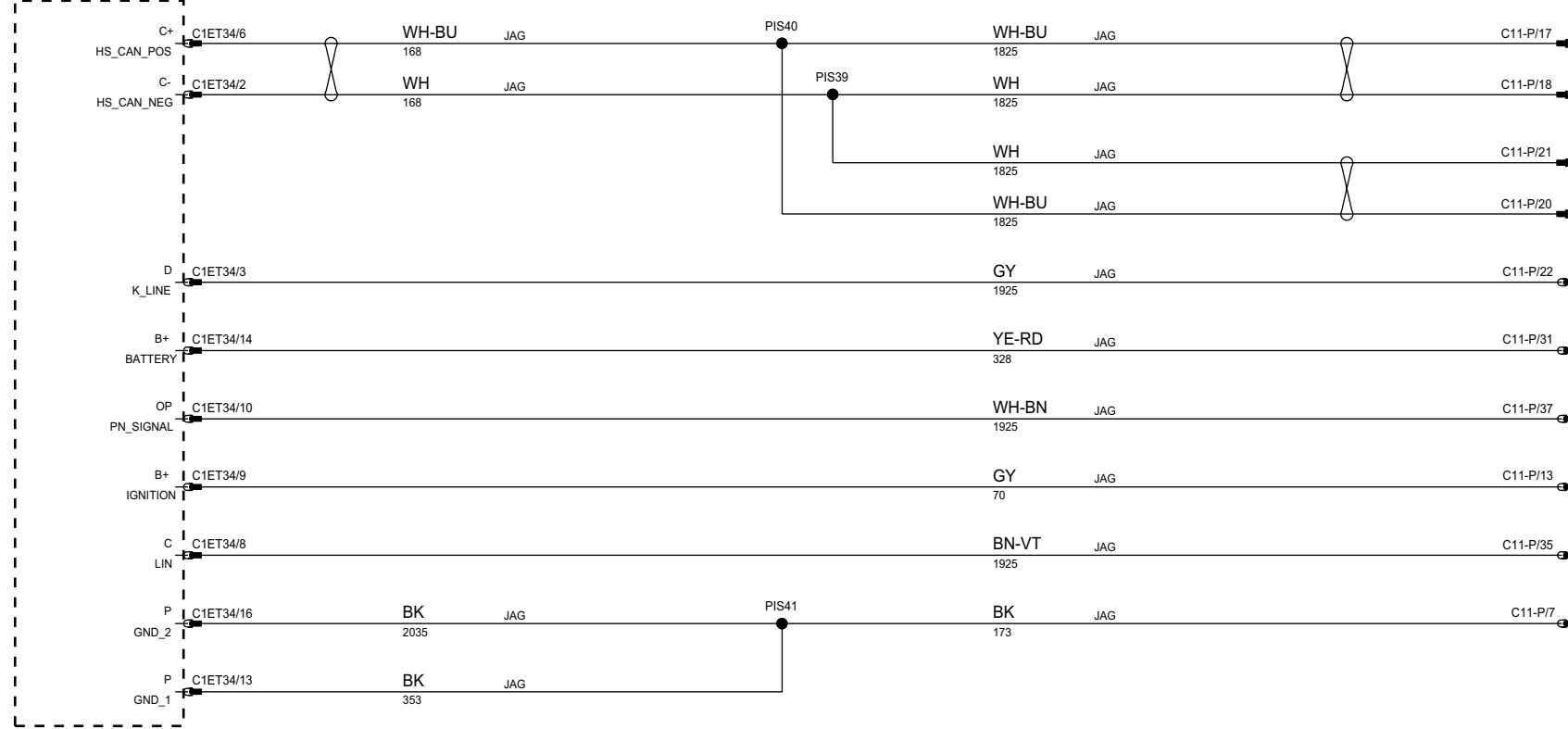

→ Refer to can bus - high speed

← Refer to engine junction box

→ Refer to transmission

**Engine control-
Module (ecm)**

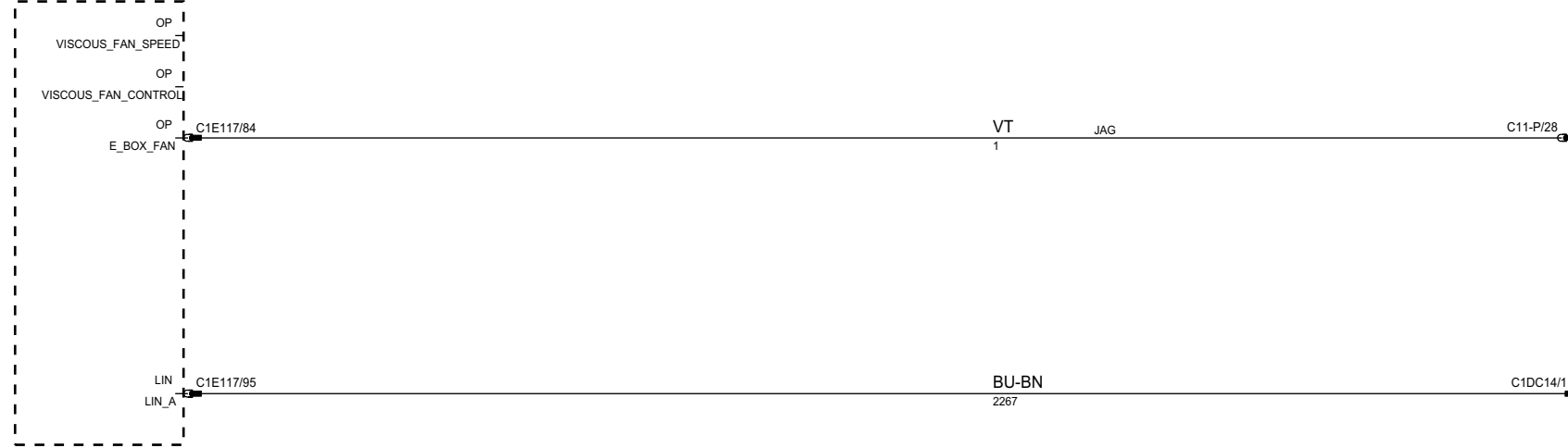

← Refer to engine junction box

XK	C11-P = PI041
XF - XJ	C11-P = C11-P

phcw93-70034-a-a3

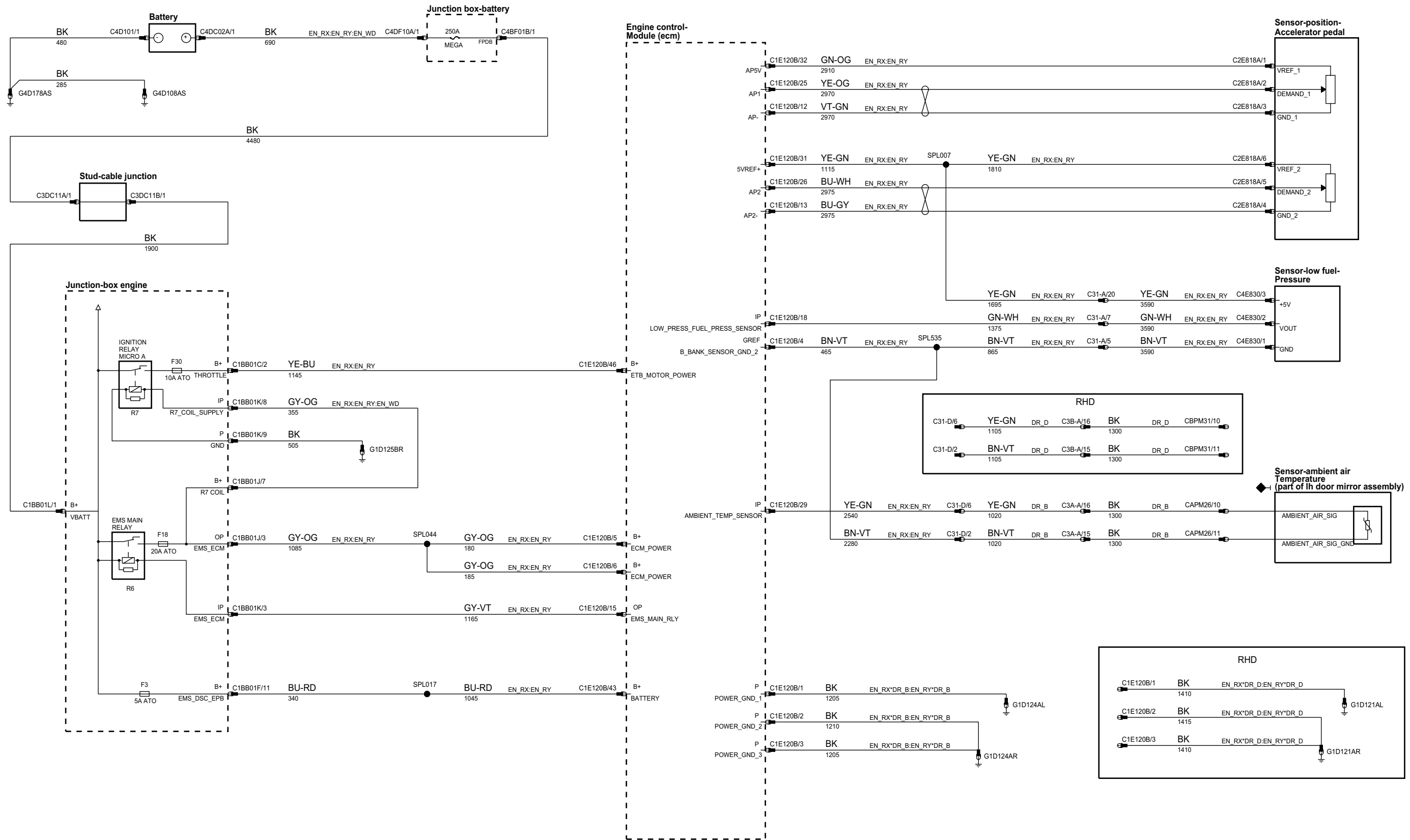

pha133-70035-j-a5

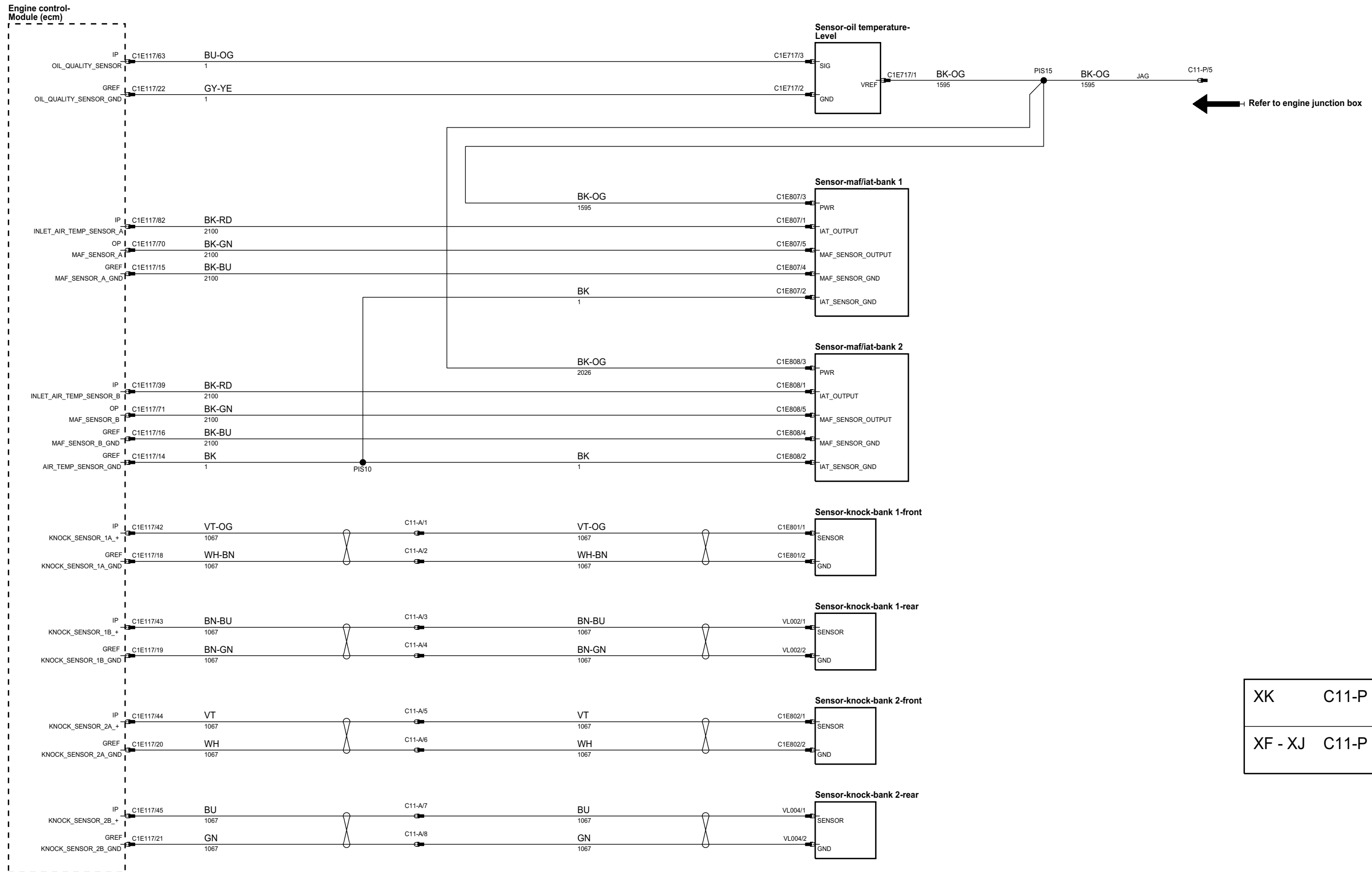

XK	C11-P = PI041
XF - XJ	C11-P = C11-P

phj133-70035-b-a5

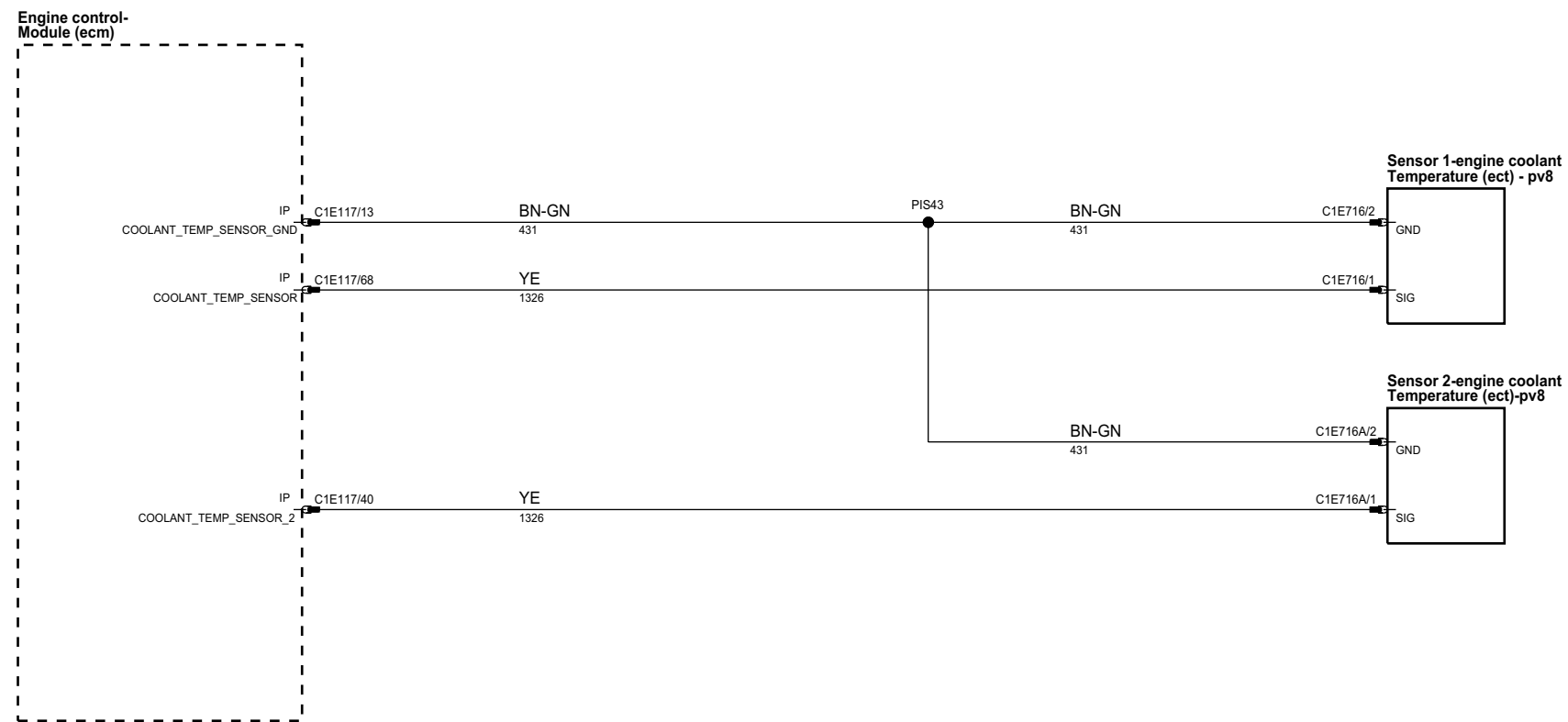

pha133-70035-ca5

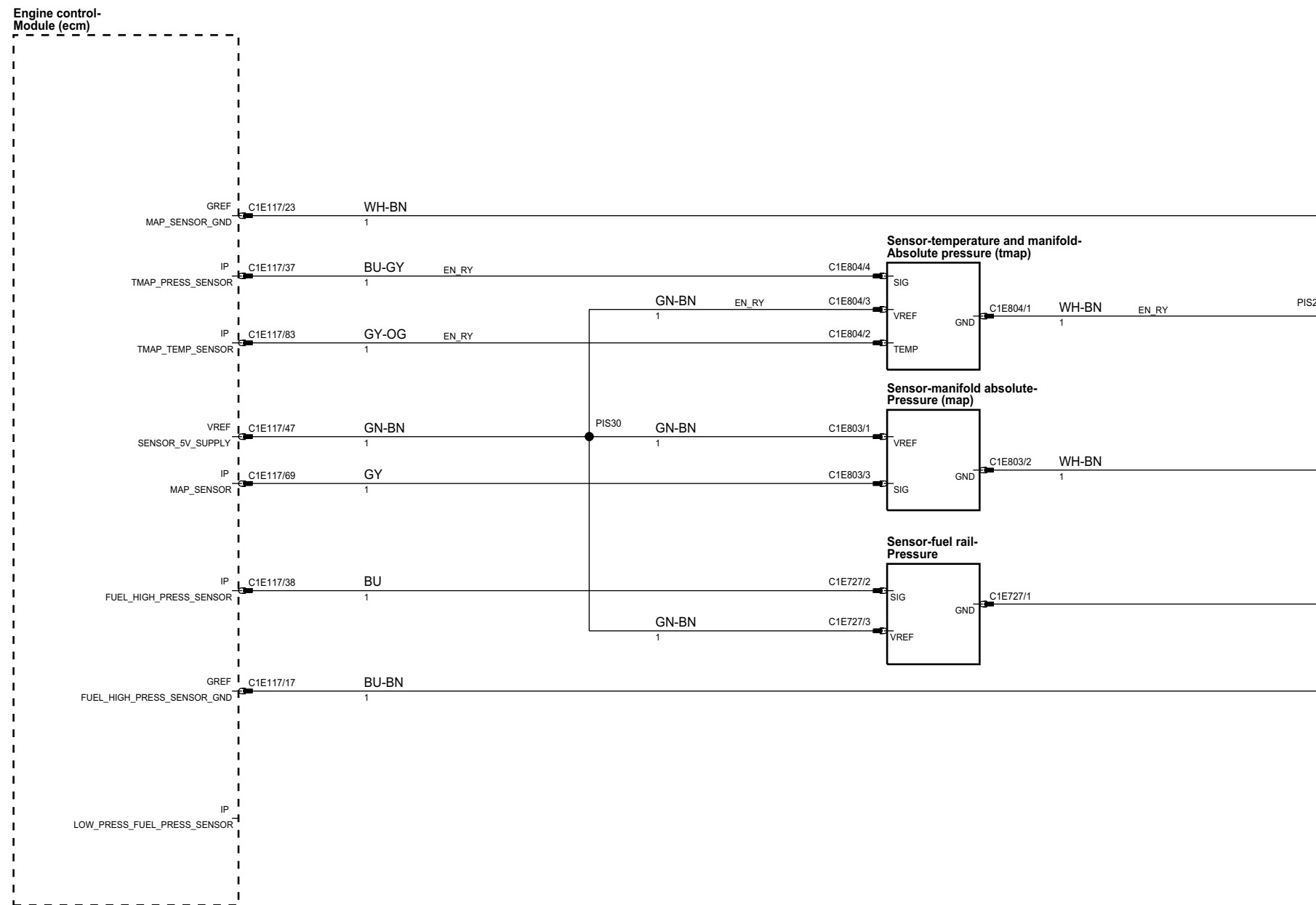

phaj133-70035-d-a5

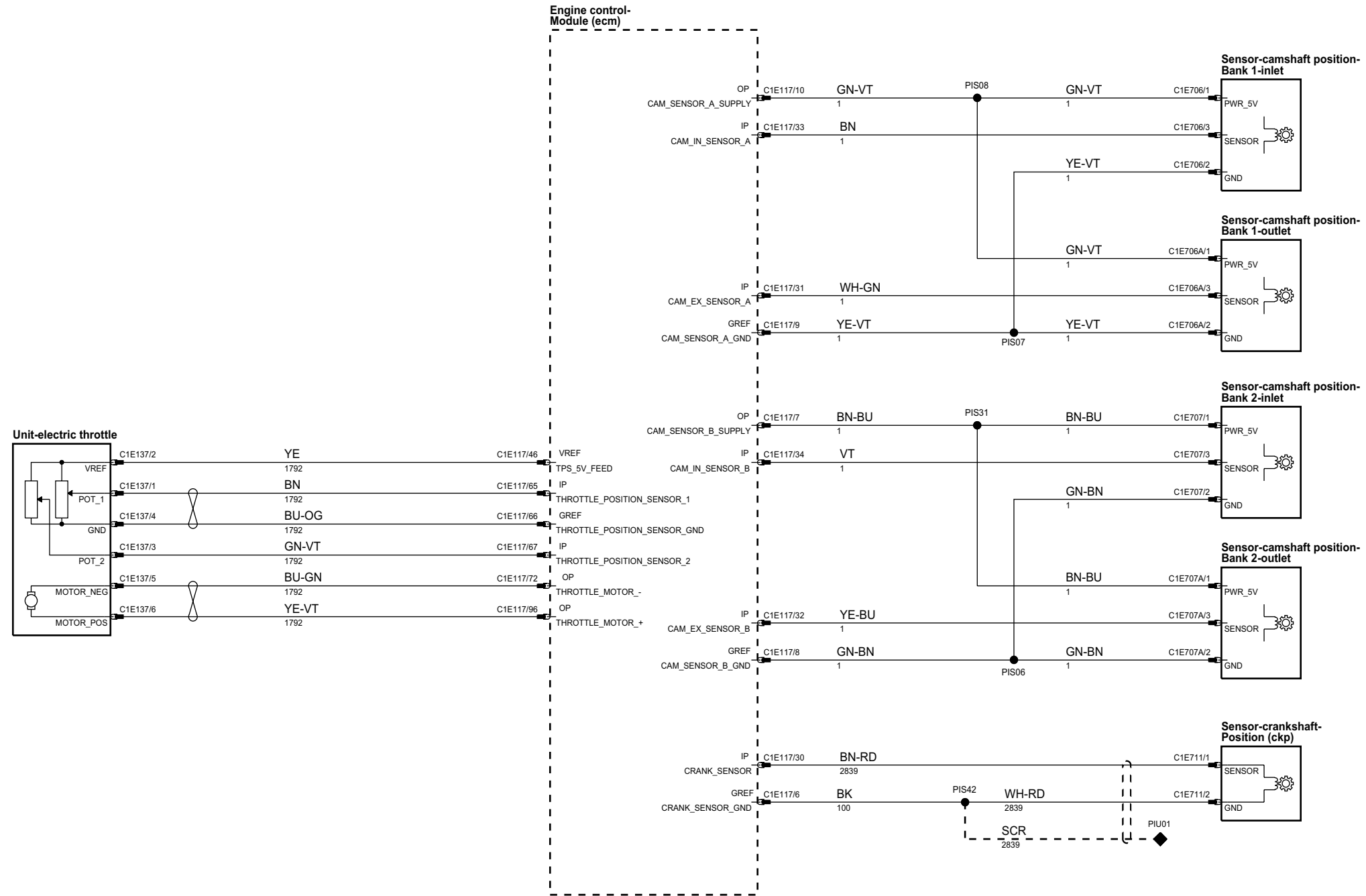

phcw93-70038-a-a3

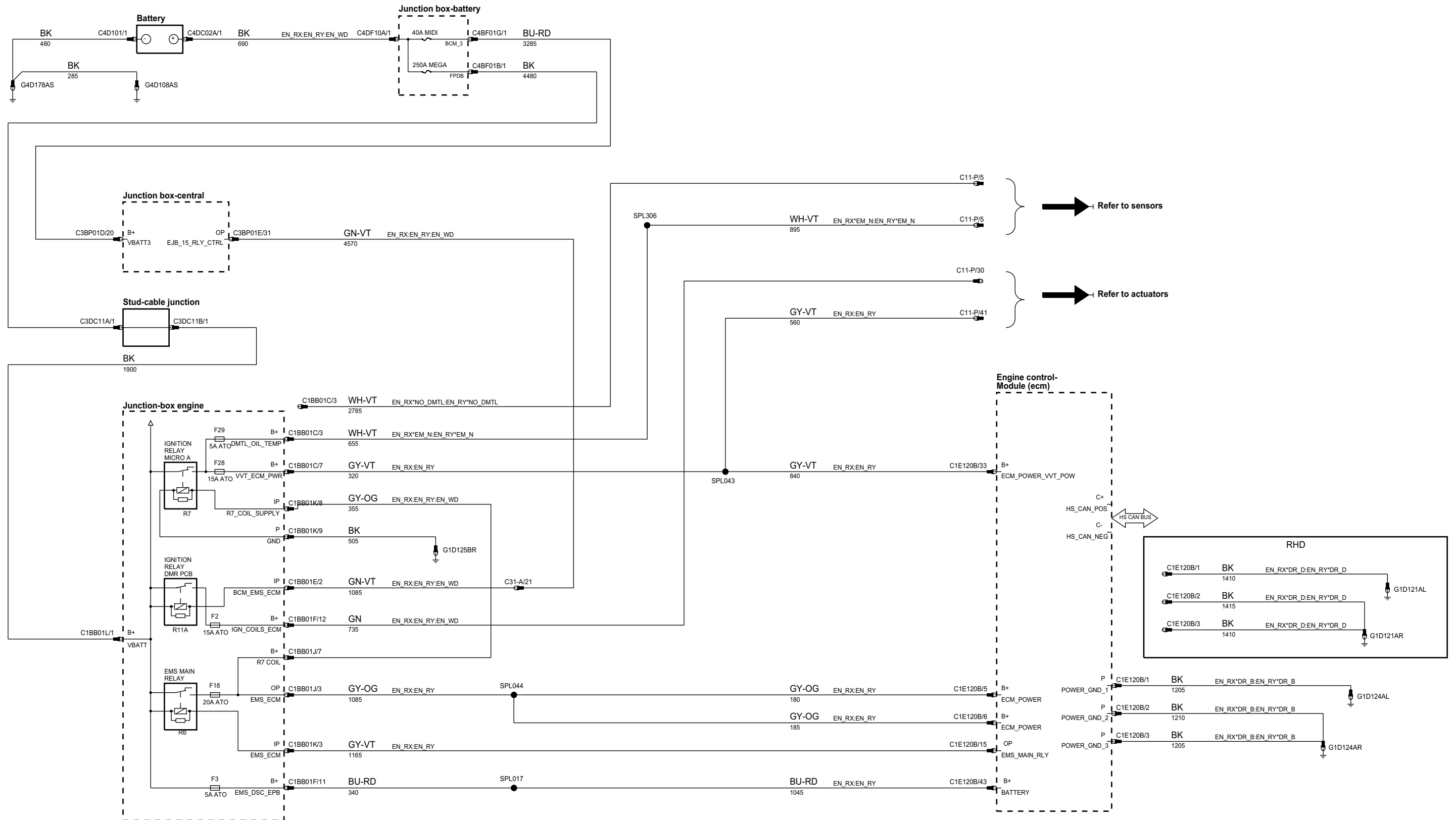

phj133-70035-4-a5

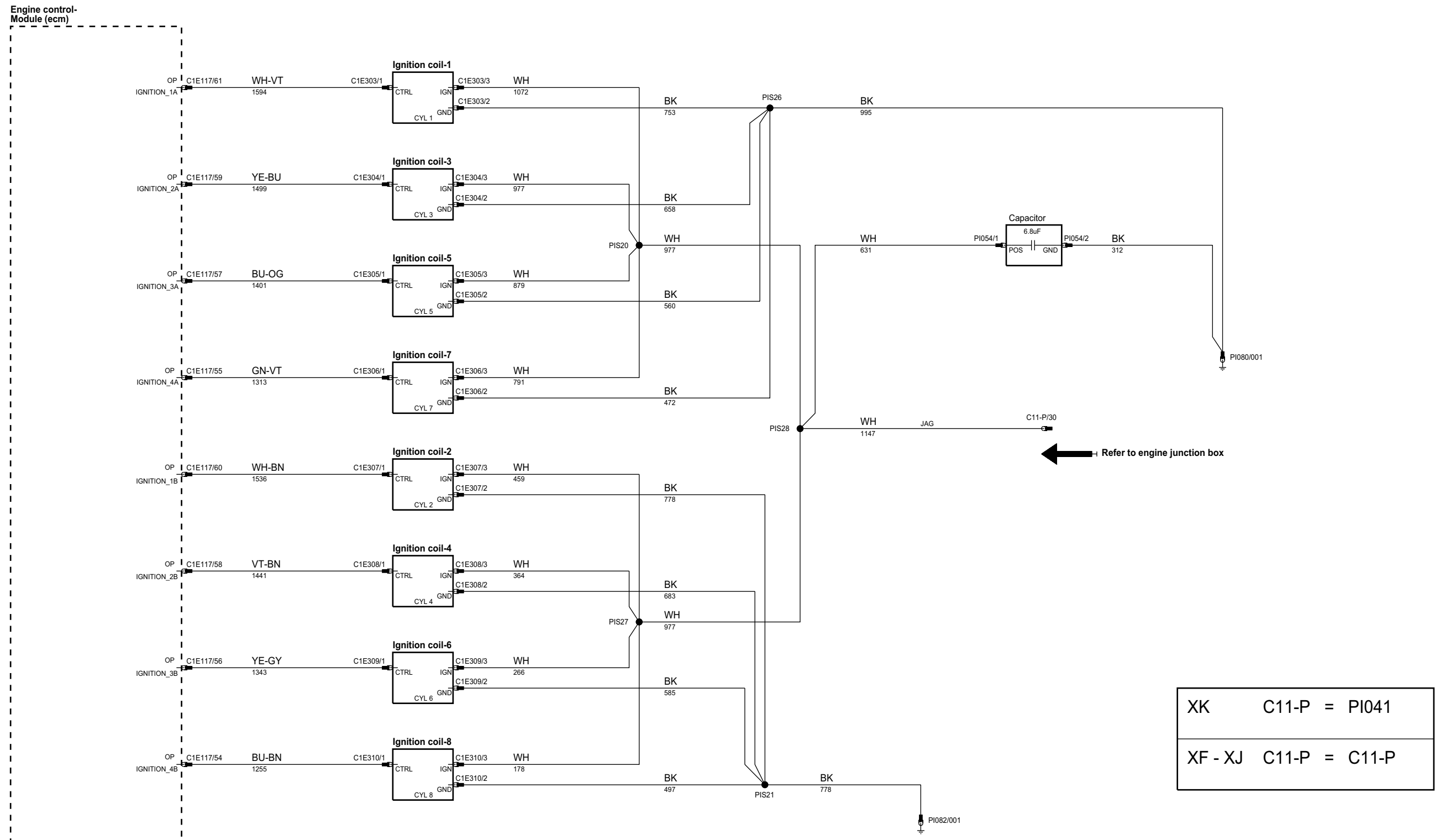

pha133-70035-g-a5

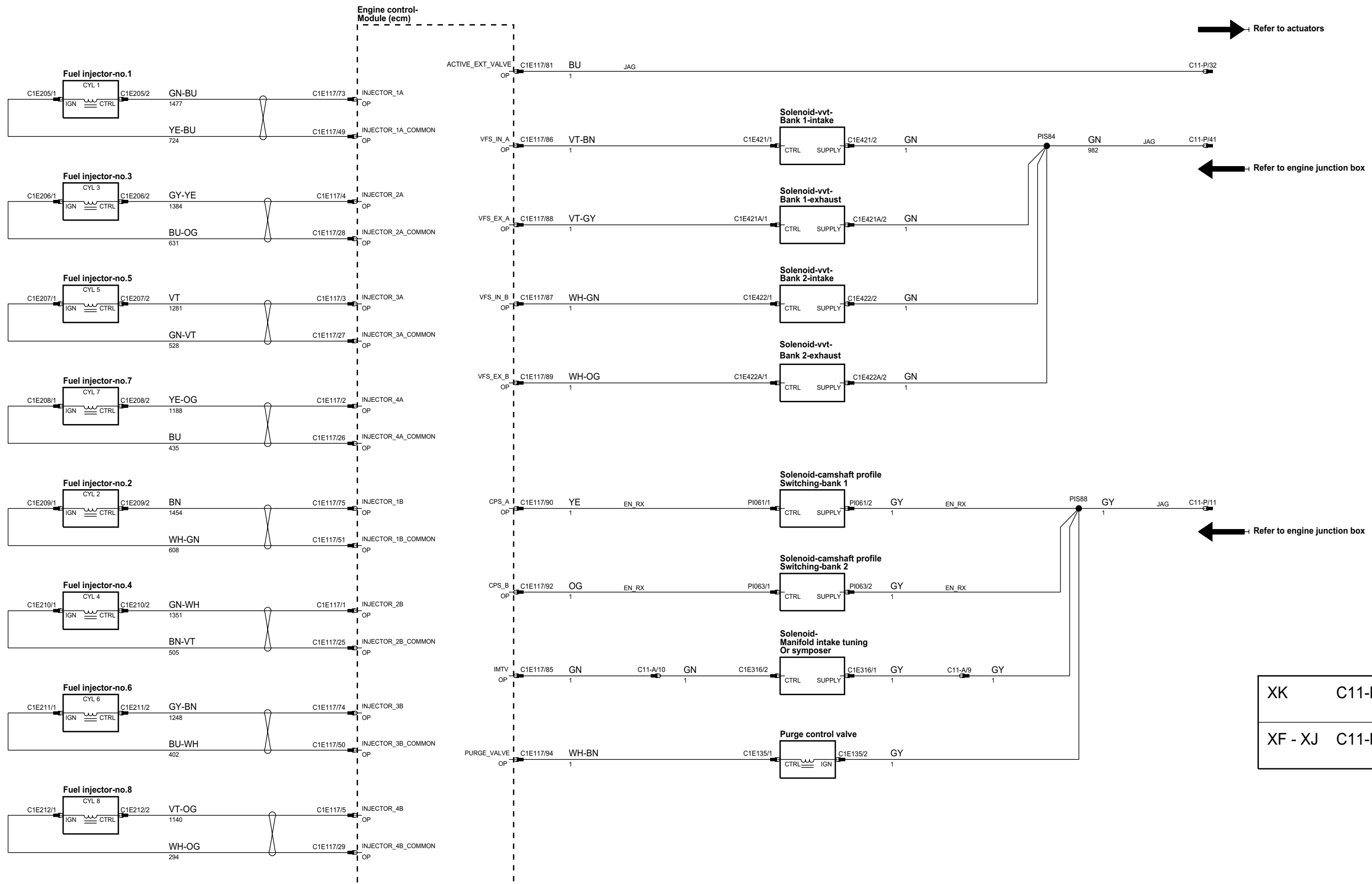

phj133-70035-h-a5

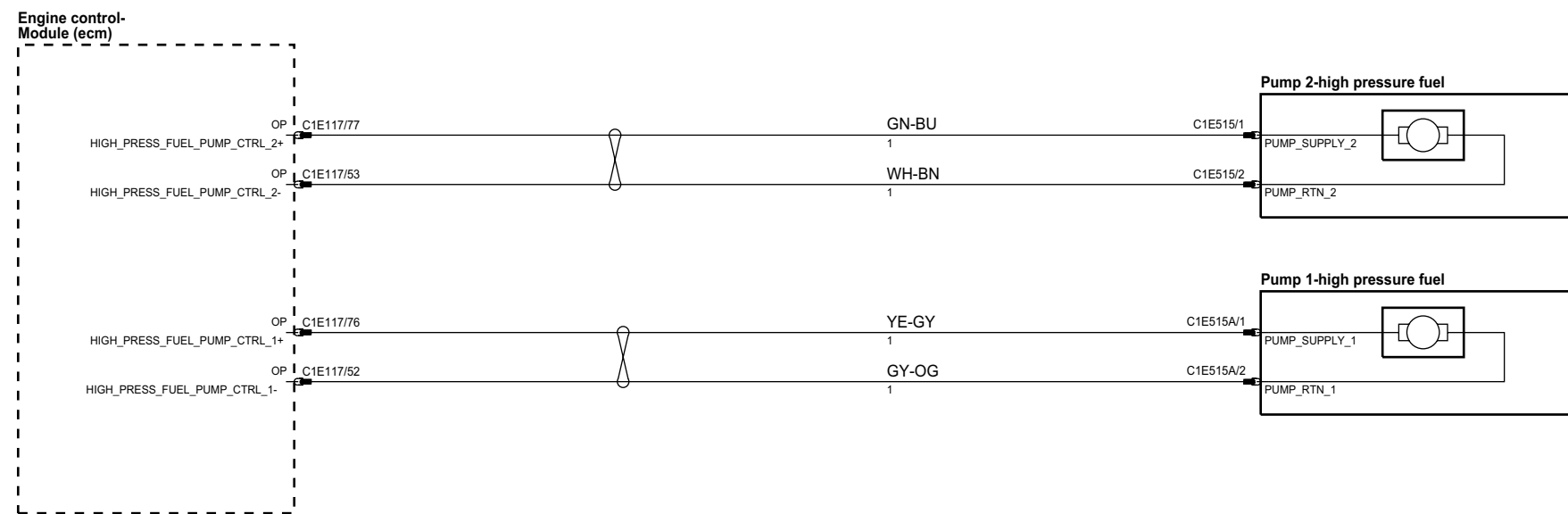

phcw93-70035-a-a3

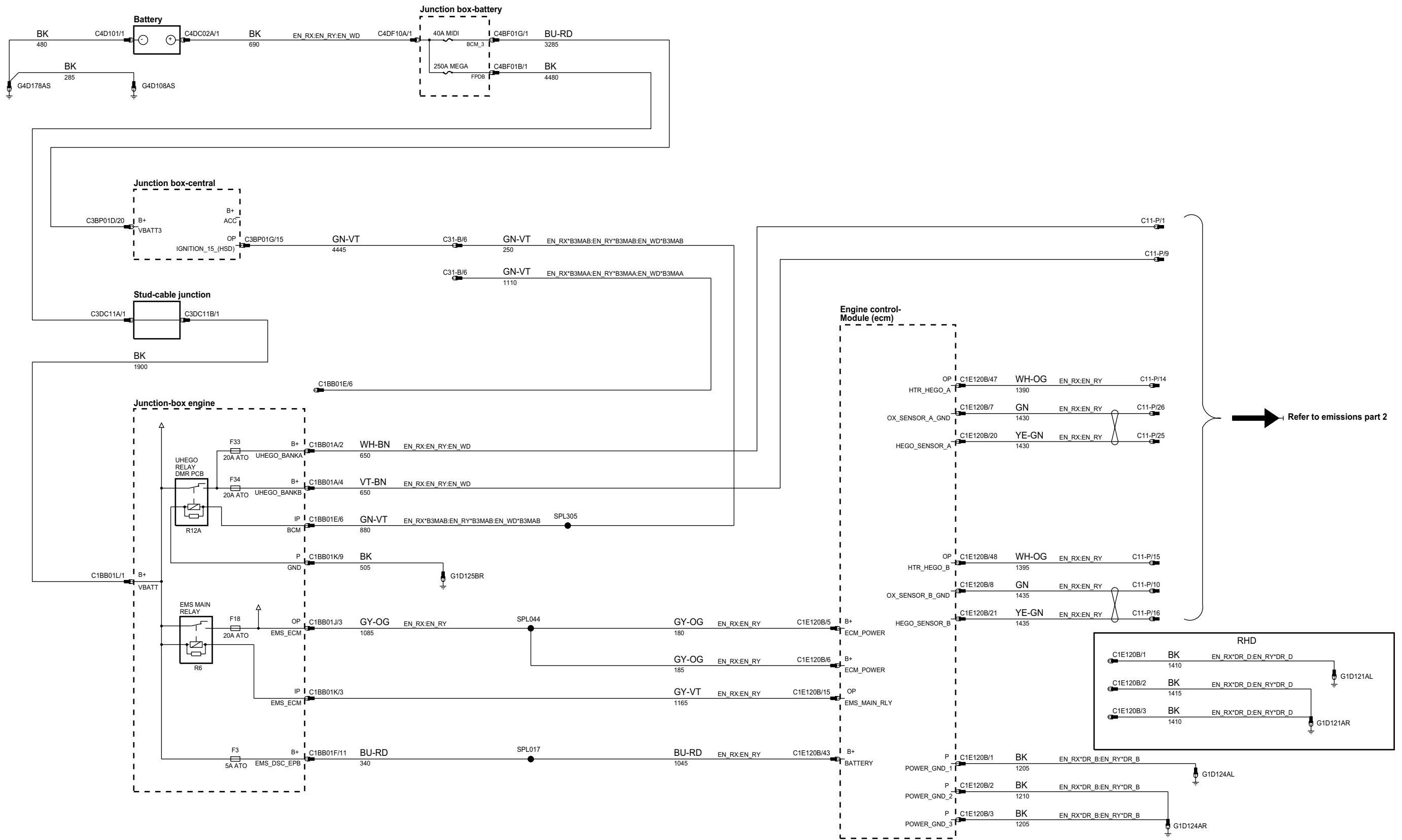

phj133-70035-e-a5

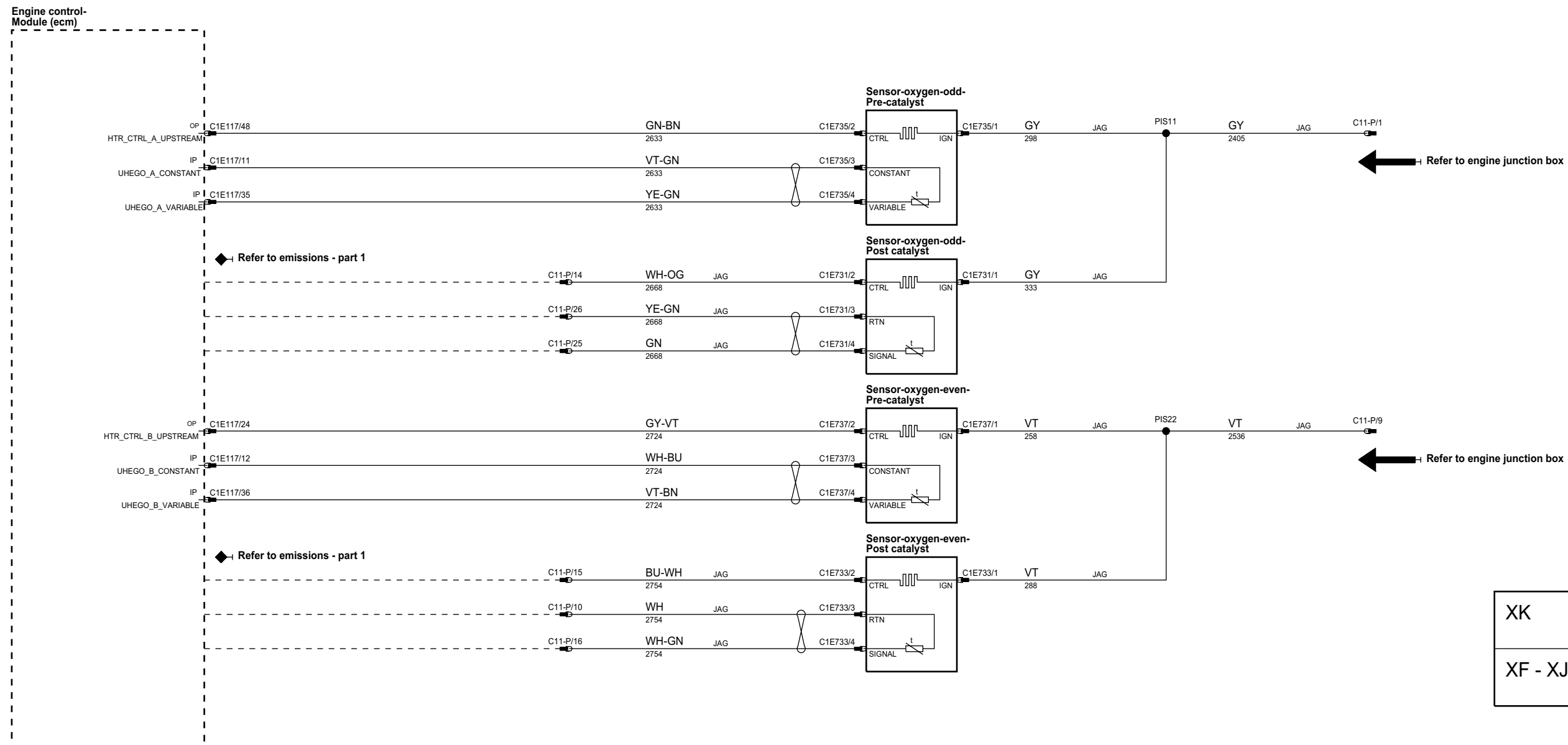

phcw93-70031-b-a3

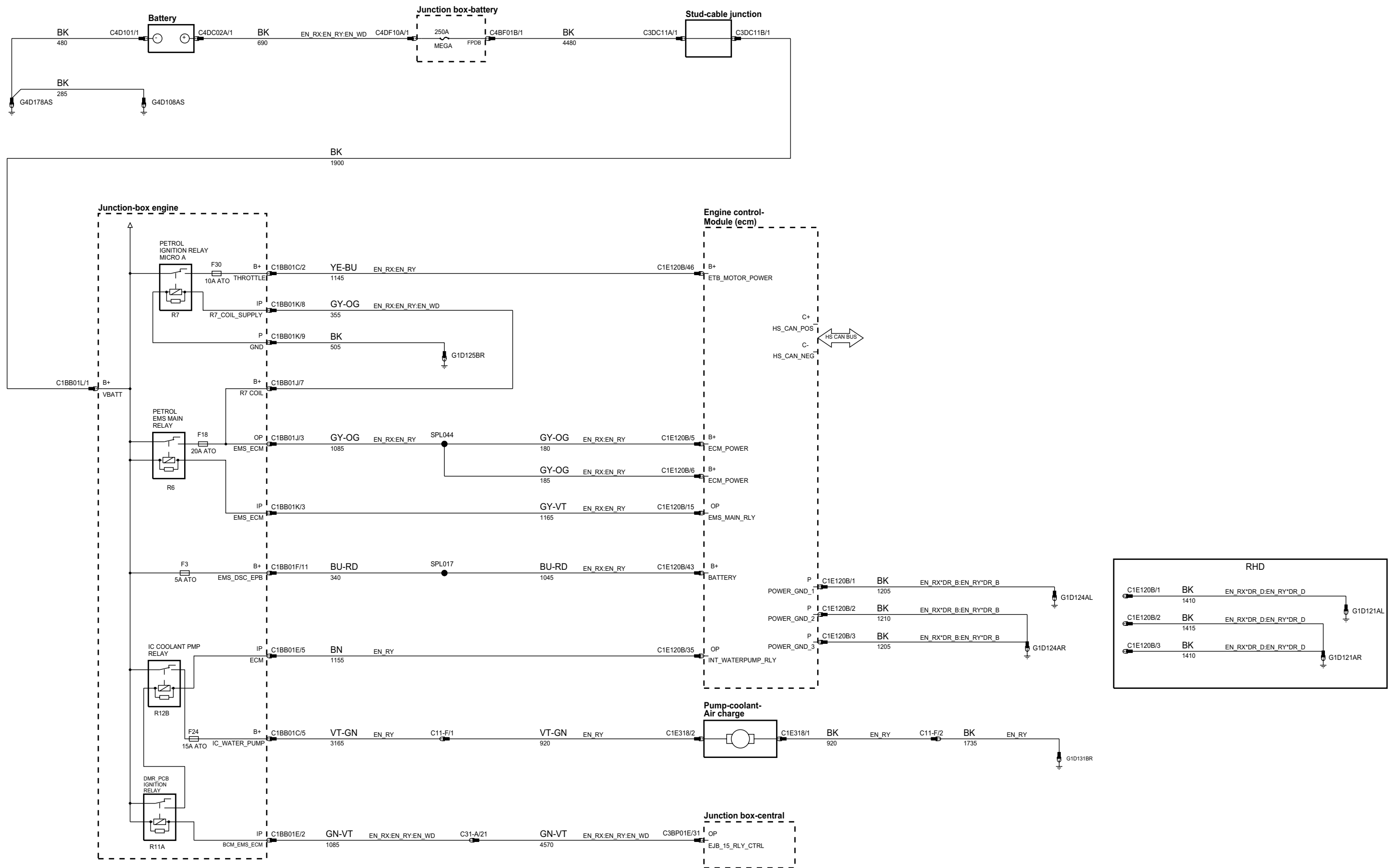

phldv6-70032-a

Clutch-compressor-air-Conditioning (a/c)

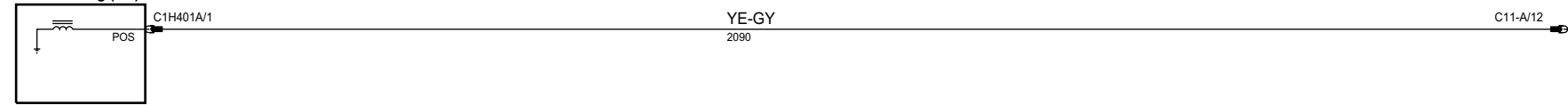

Refrigerant solenoid Valve

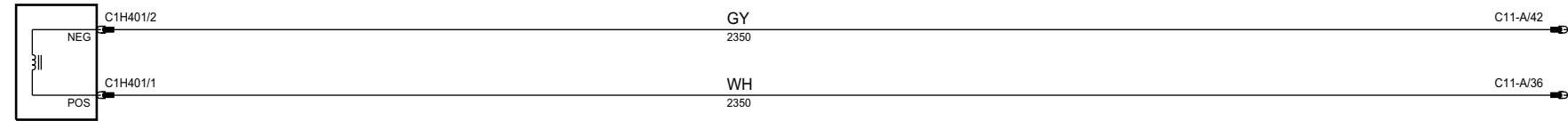

Switch-oil pressure

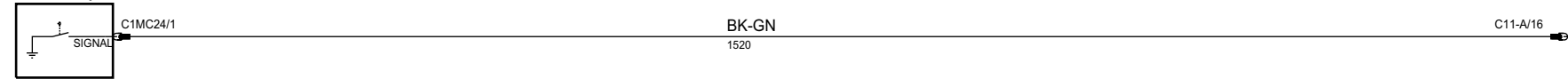

Starter motor

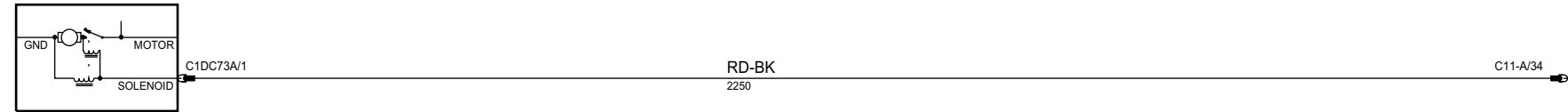

Generator

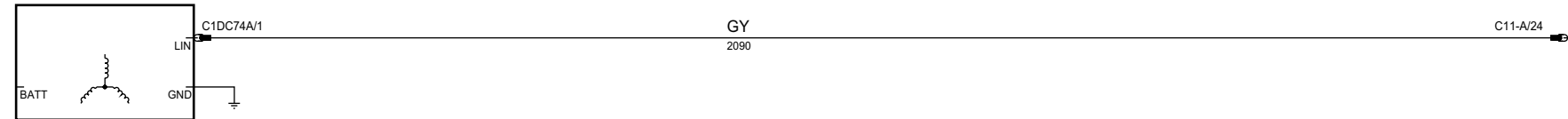

← Refer to climate control

← Refer to instrument cluster

← Refer to dv6 - starting

← Refer to dv6 - charging

← Refer to transmission

◆ Tcm and control valve body

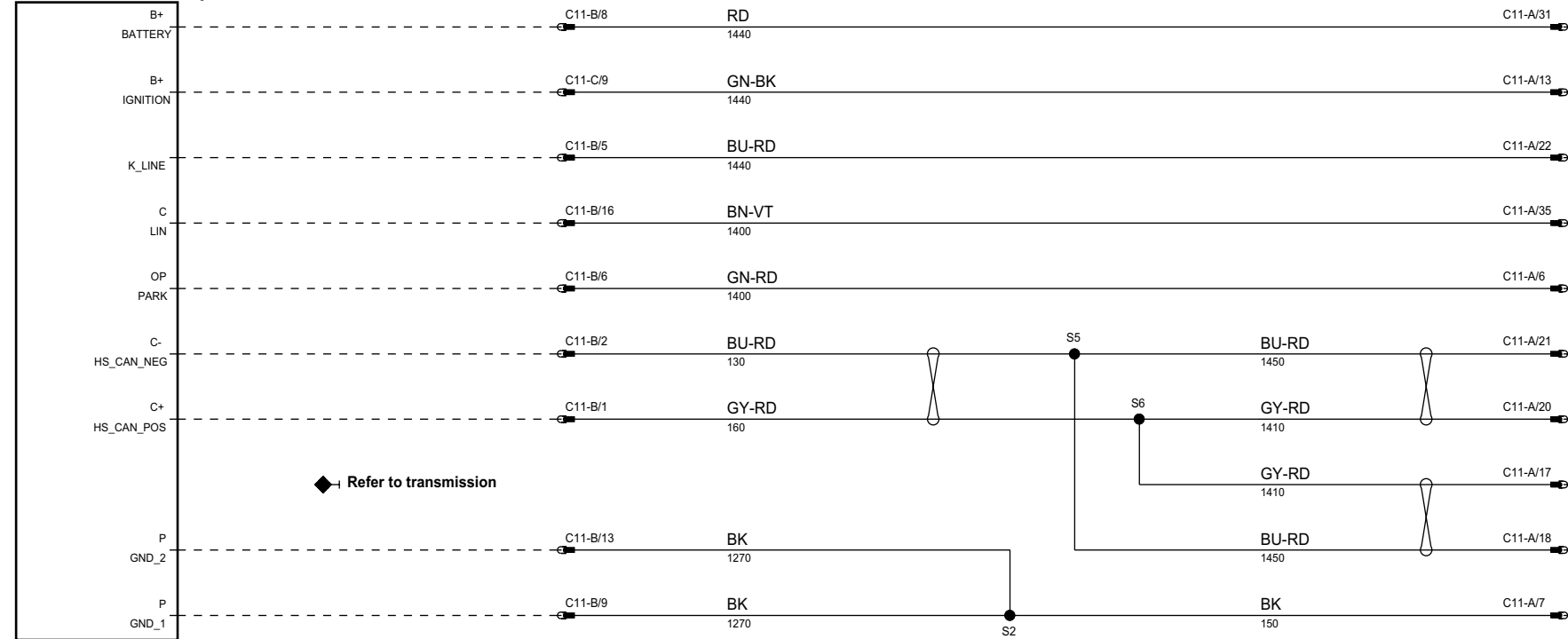

◆ Refer to transmission

C11-A	=	C11-P
C11-B	=	C11-N
C11-C	=	C11-M

phdv6-70032-b

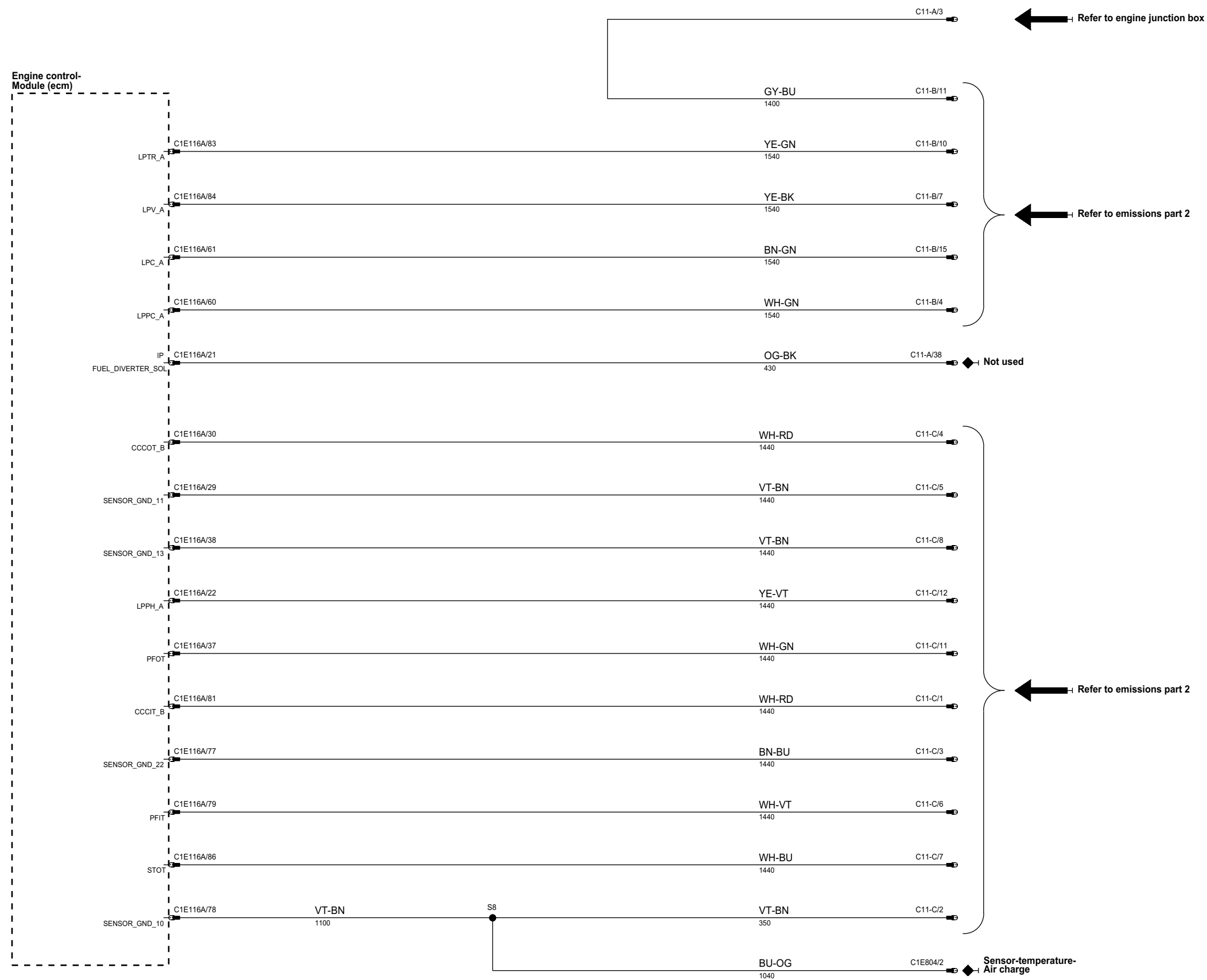

C11-A = C11-P
C11-B = C11-N
C11-C = C11-M

phdsv6-70032-c

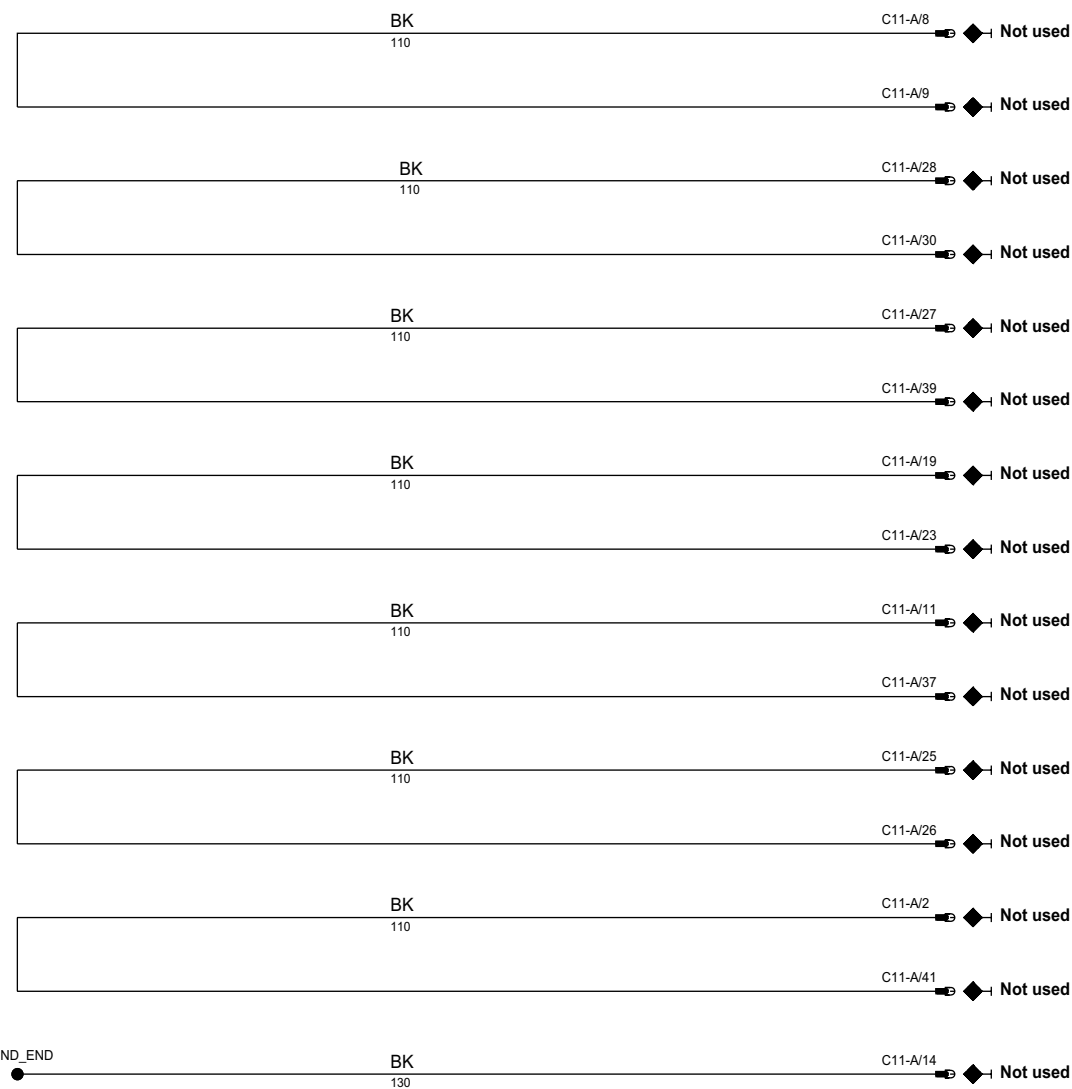
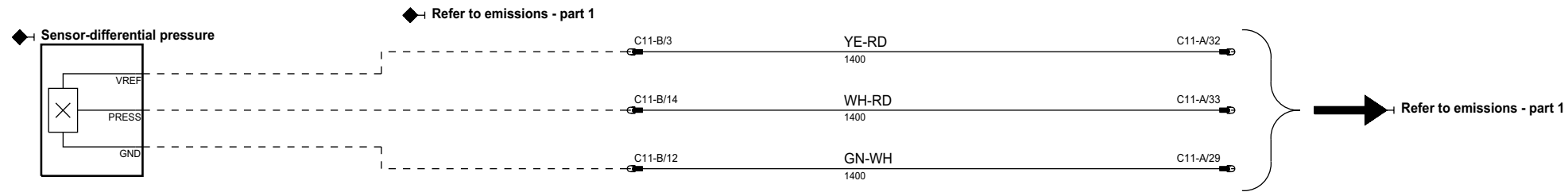

C11-A	=	C11-P
C11-B	=	C11-N
C11-C	=	C11-M

phdsv6-70034-a

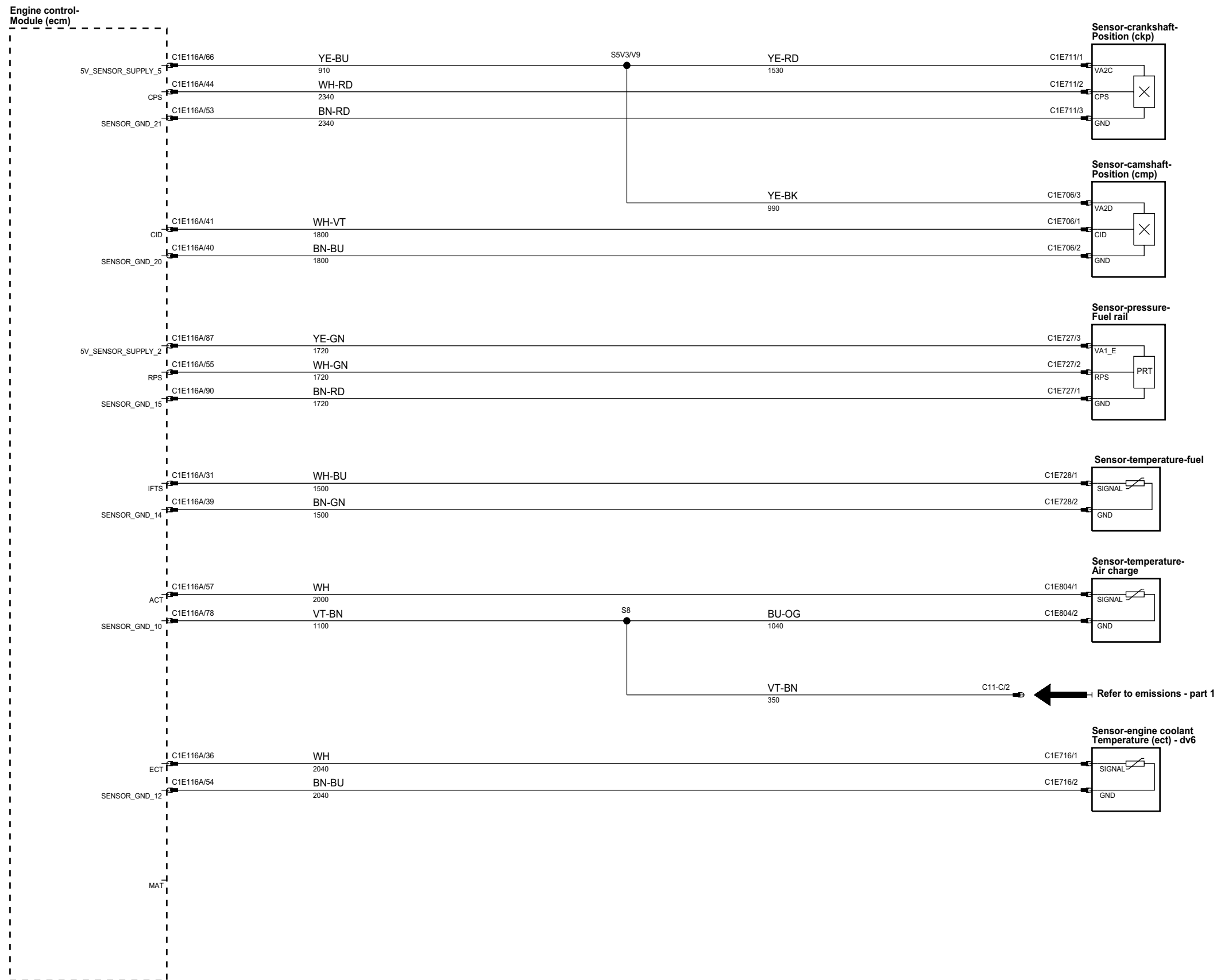

C11-A	=	C11-P
C11-B	=	C11-N
C11-C	=	C11-M

phtdv6-70034-b

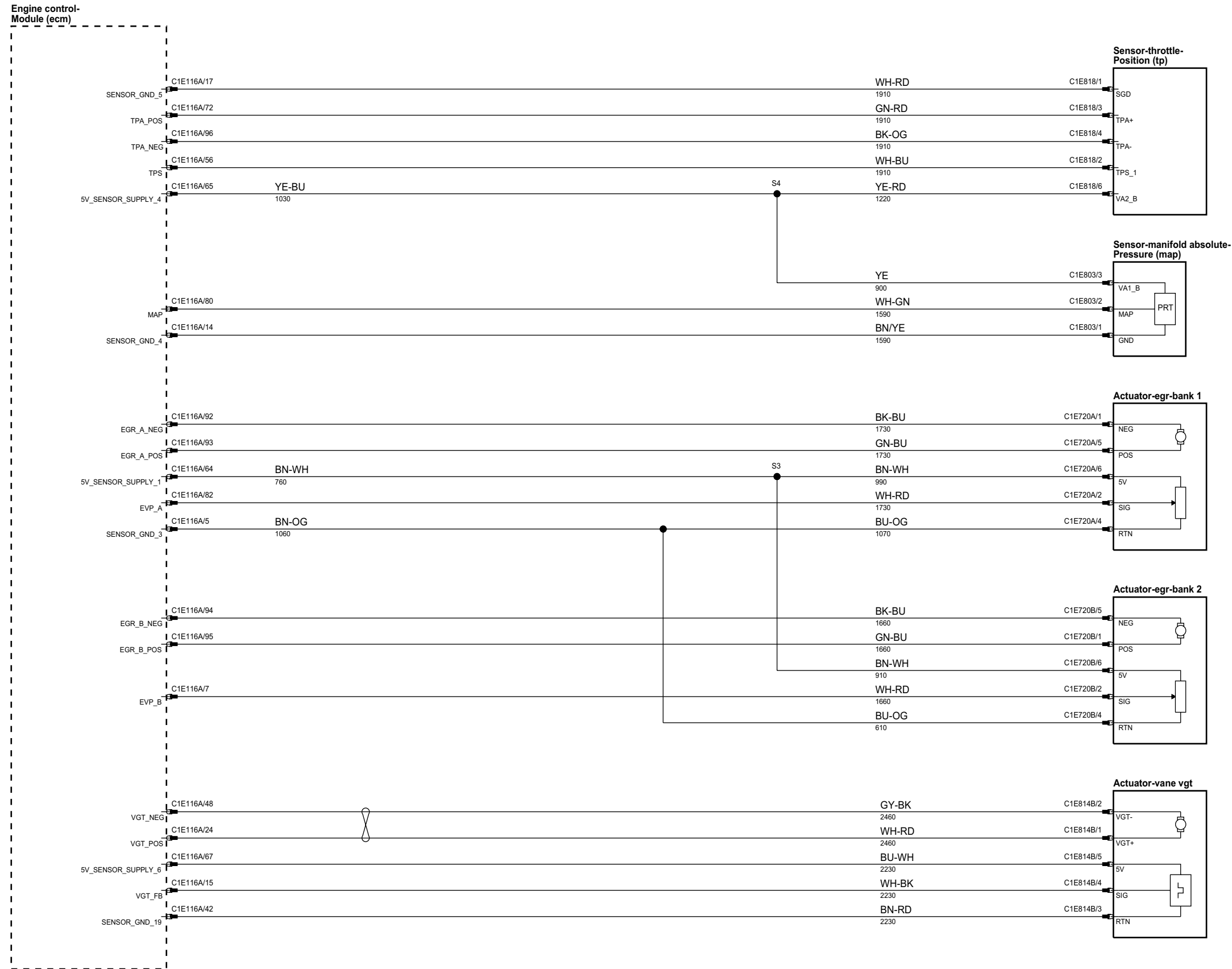

C11-A	=	C11-P
C11-B	=	C11-N
C11-C	=	C11-M

phd6-70034-c

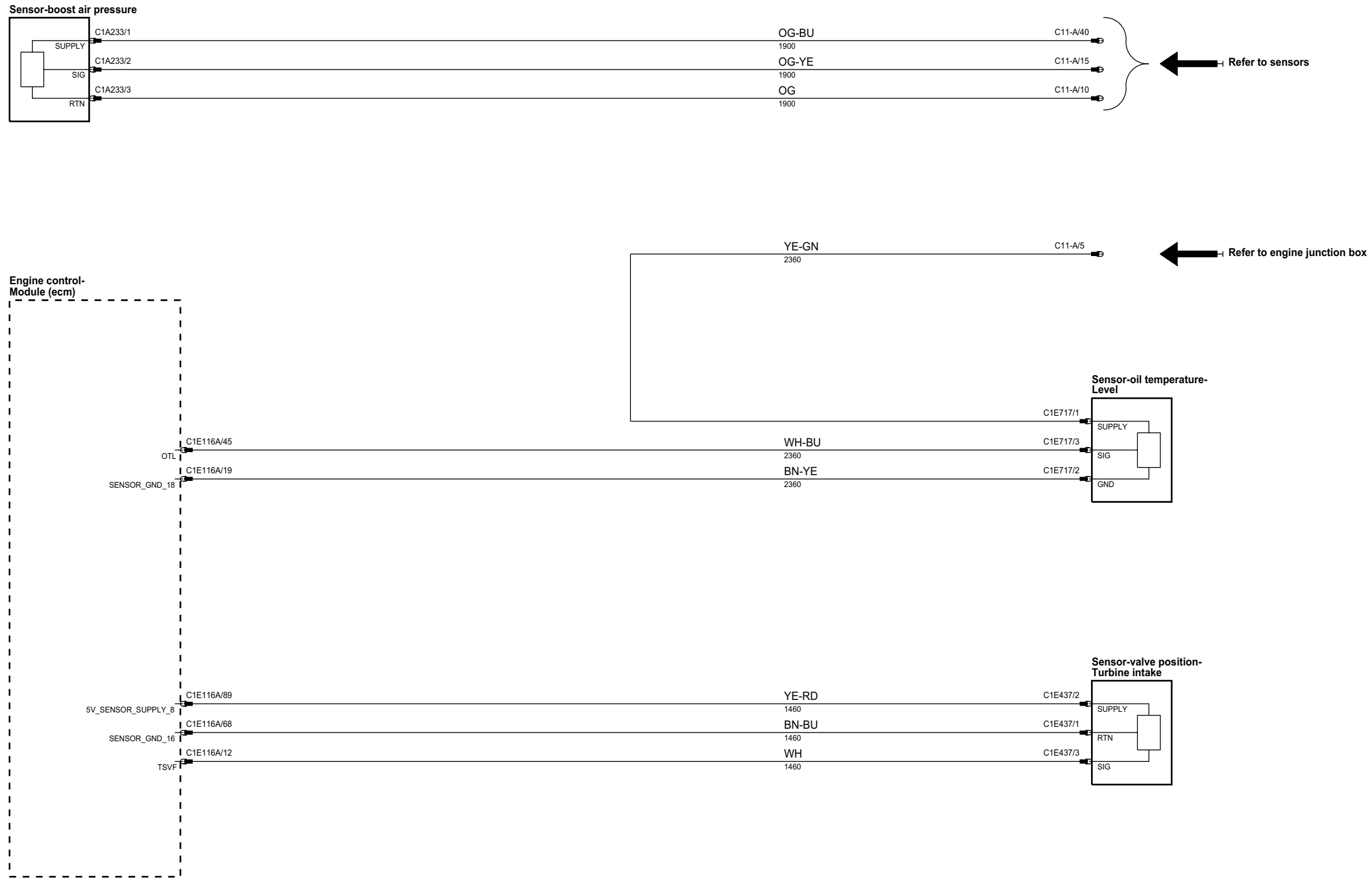

C11-A	=	C11-P
C11-B	=	C11-N
C11-C	=	C11-M

phcw93-70034-d-a3

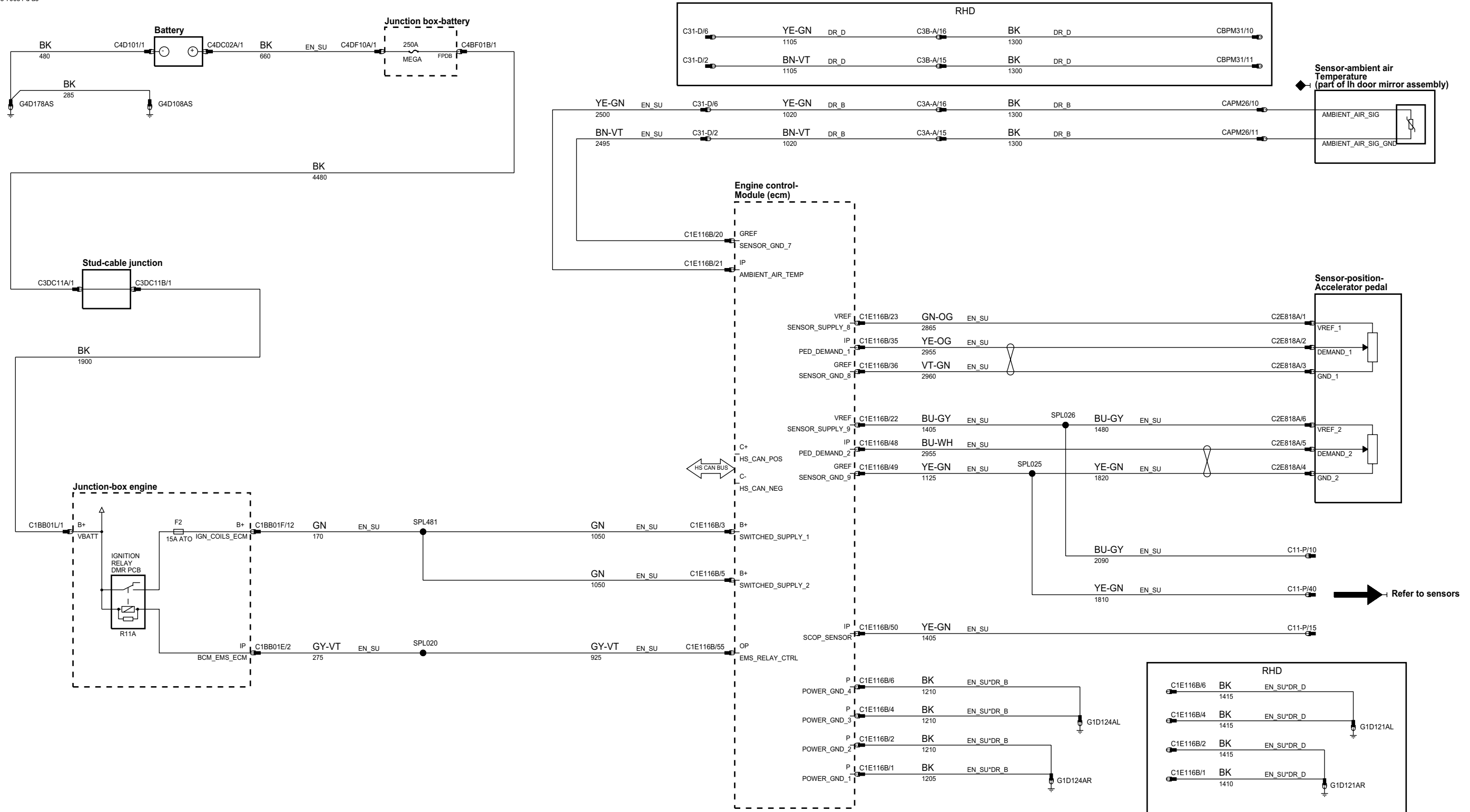

phd6-70038-a

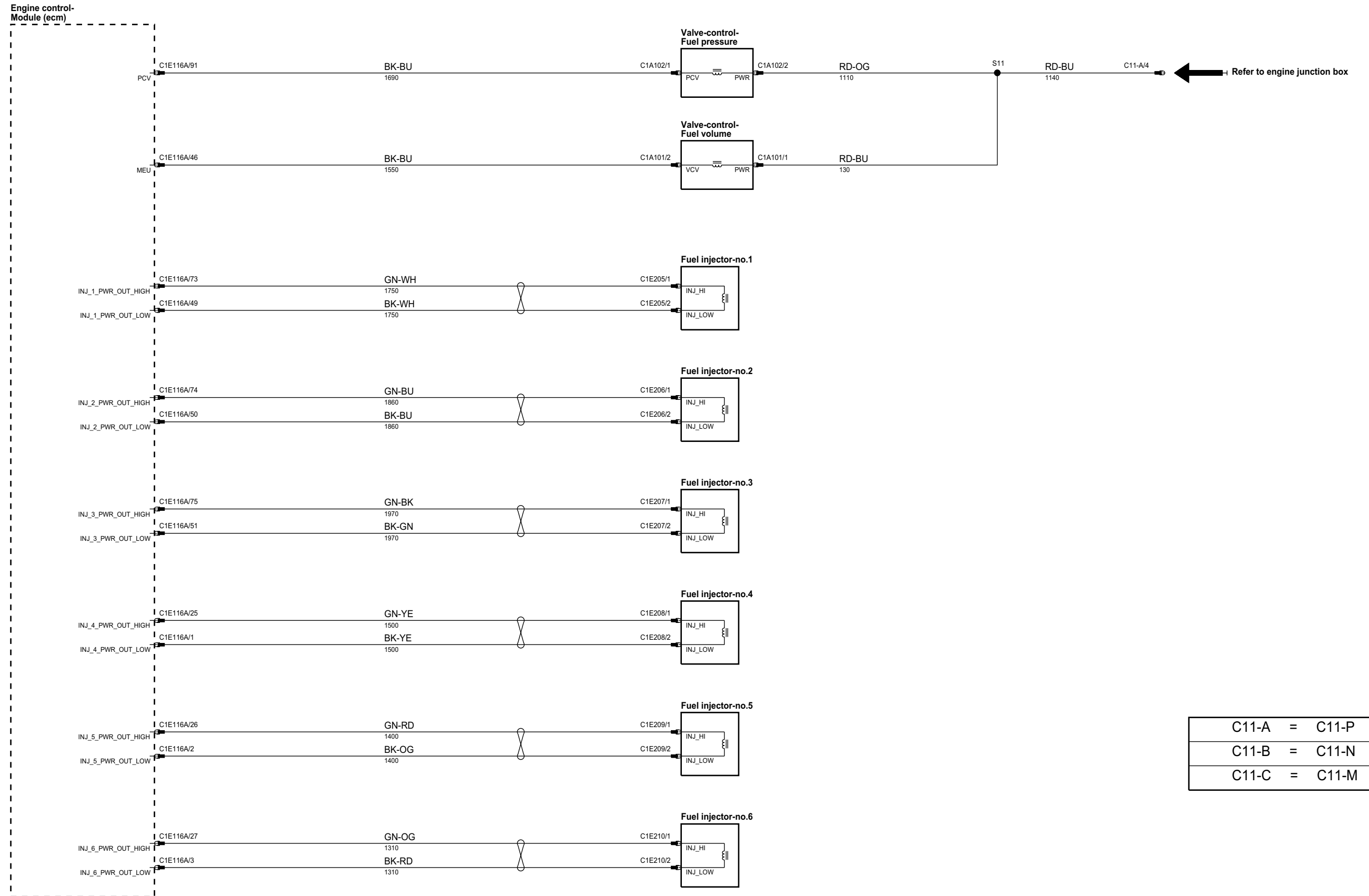

phtdv6-70038-b

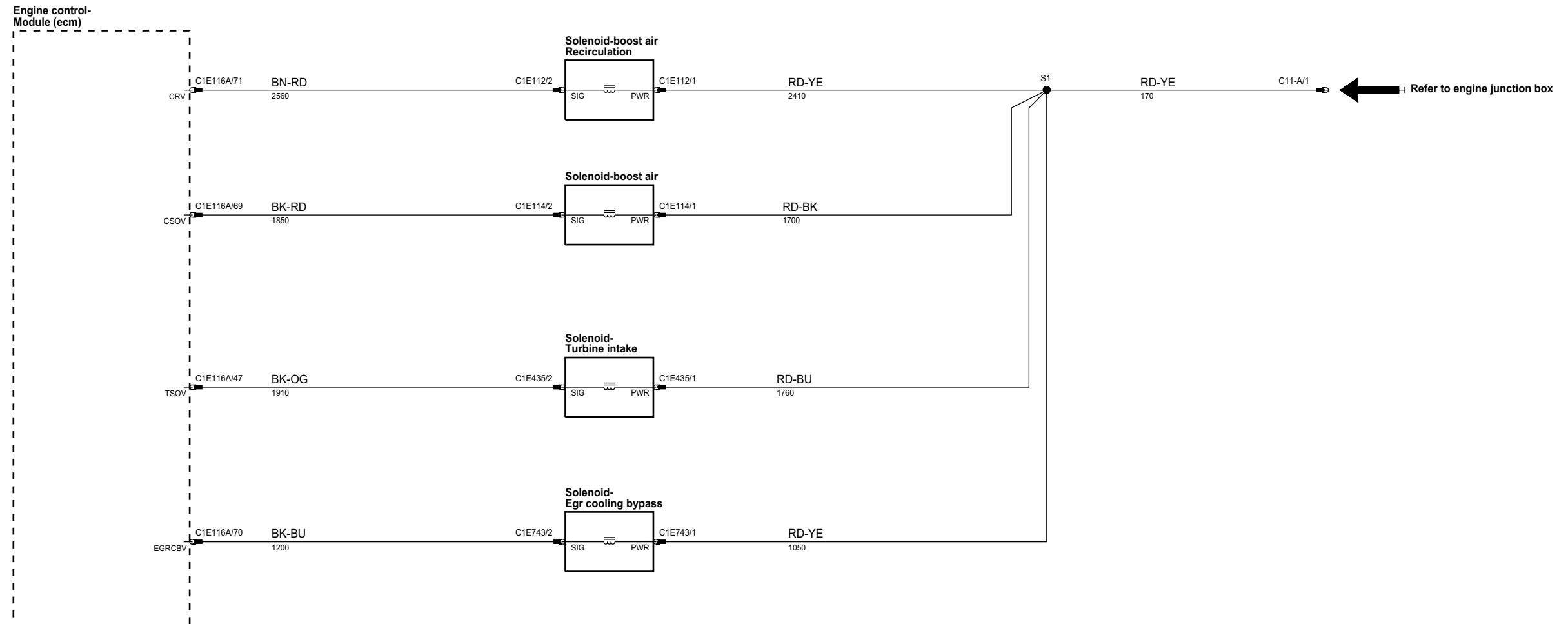

C11-A	=	C11-P
C11-B	=	C11-N
C11-C	=	C11-M

phcw93-70038-d-a3

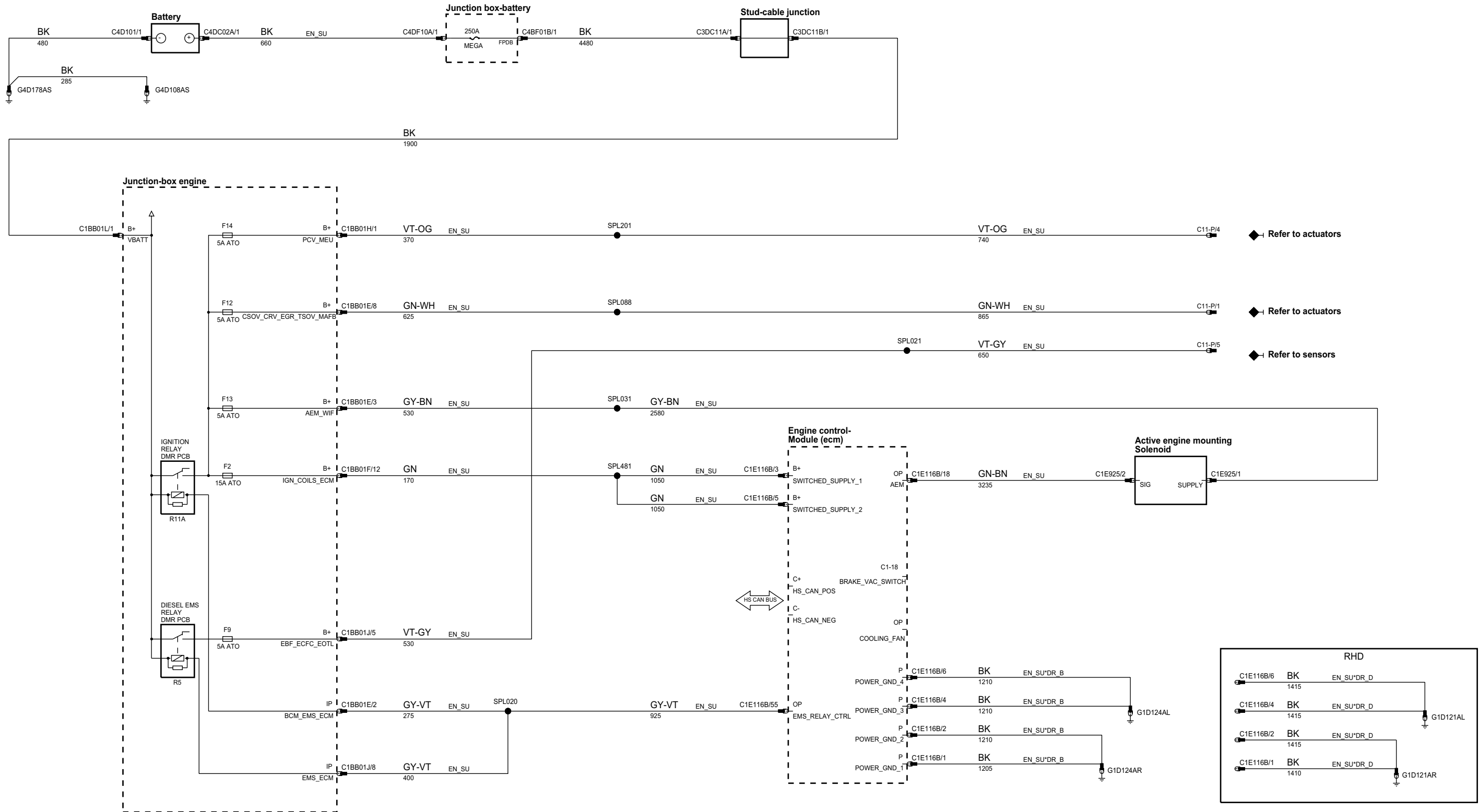

phcw93-70037-d-a3

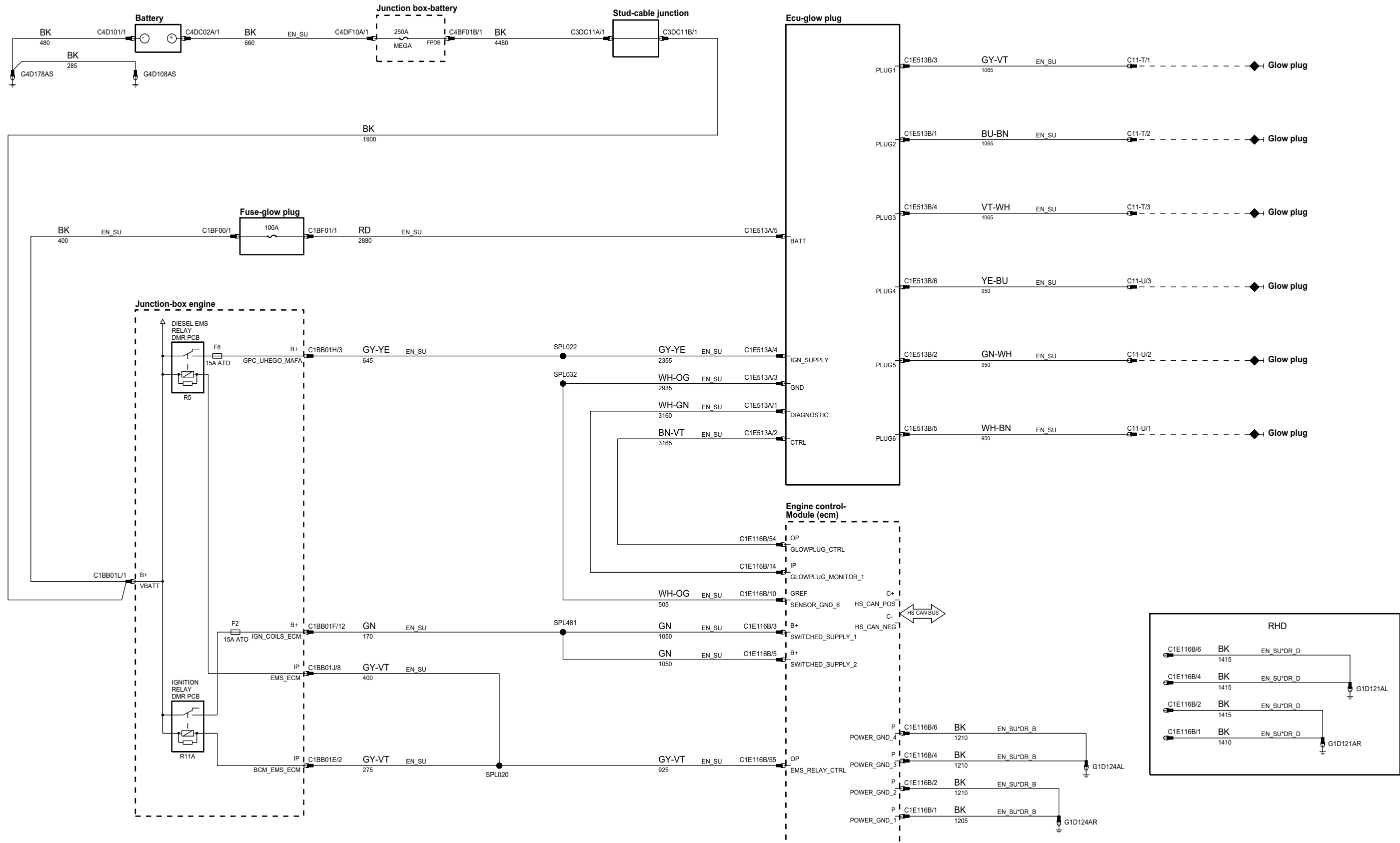

phcw93-70035-d-a3

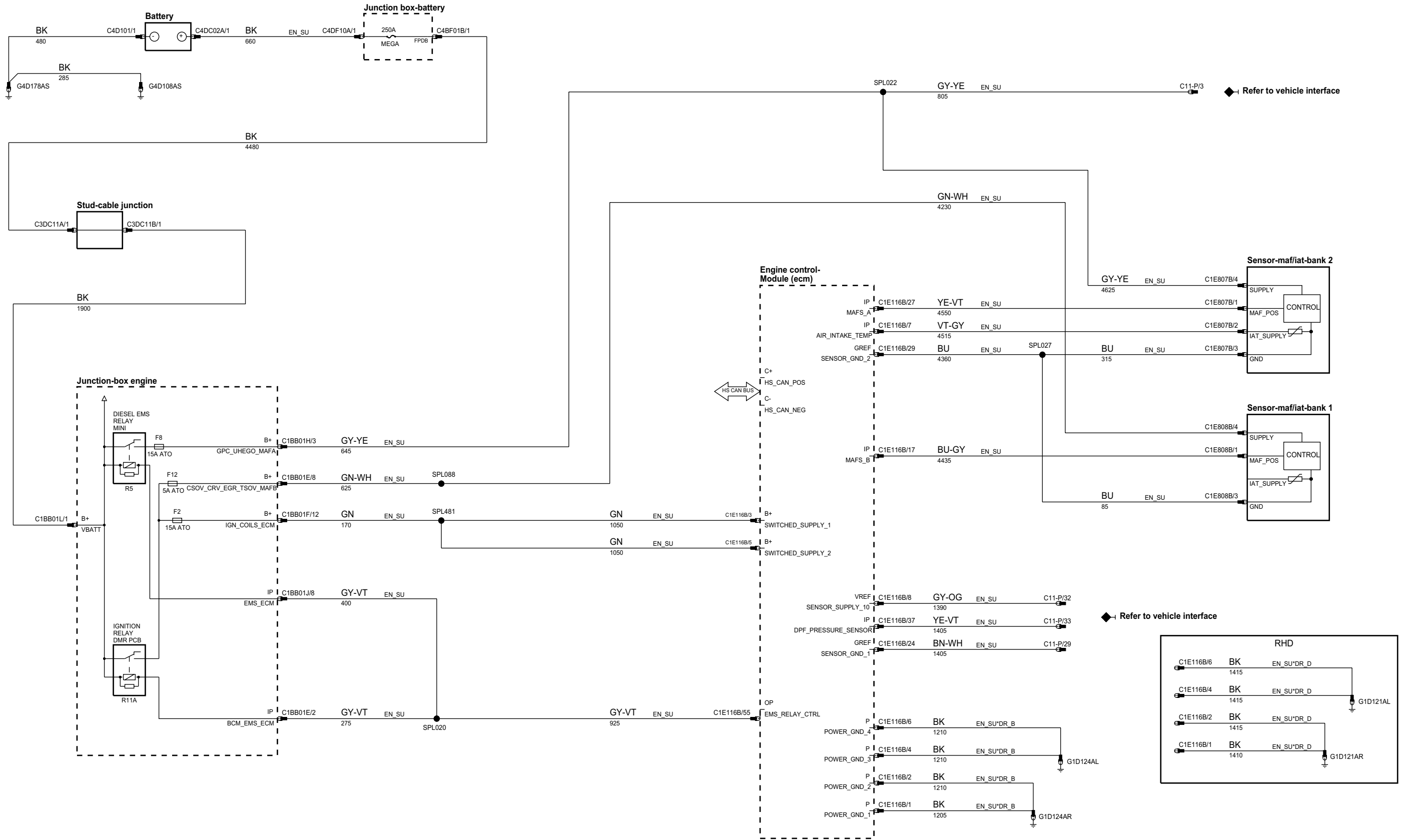

phcw93-70035-d2-a3

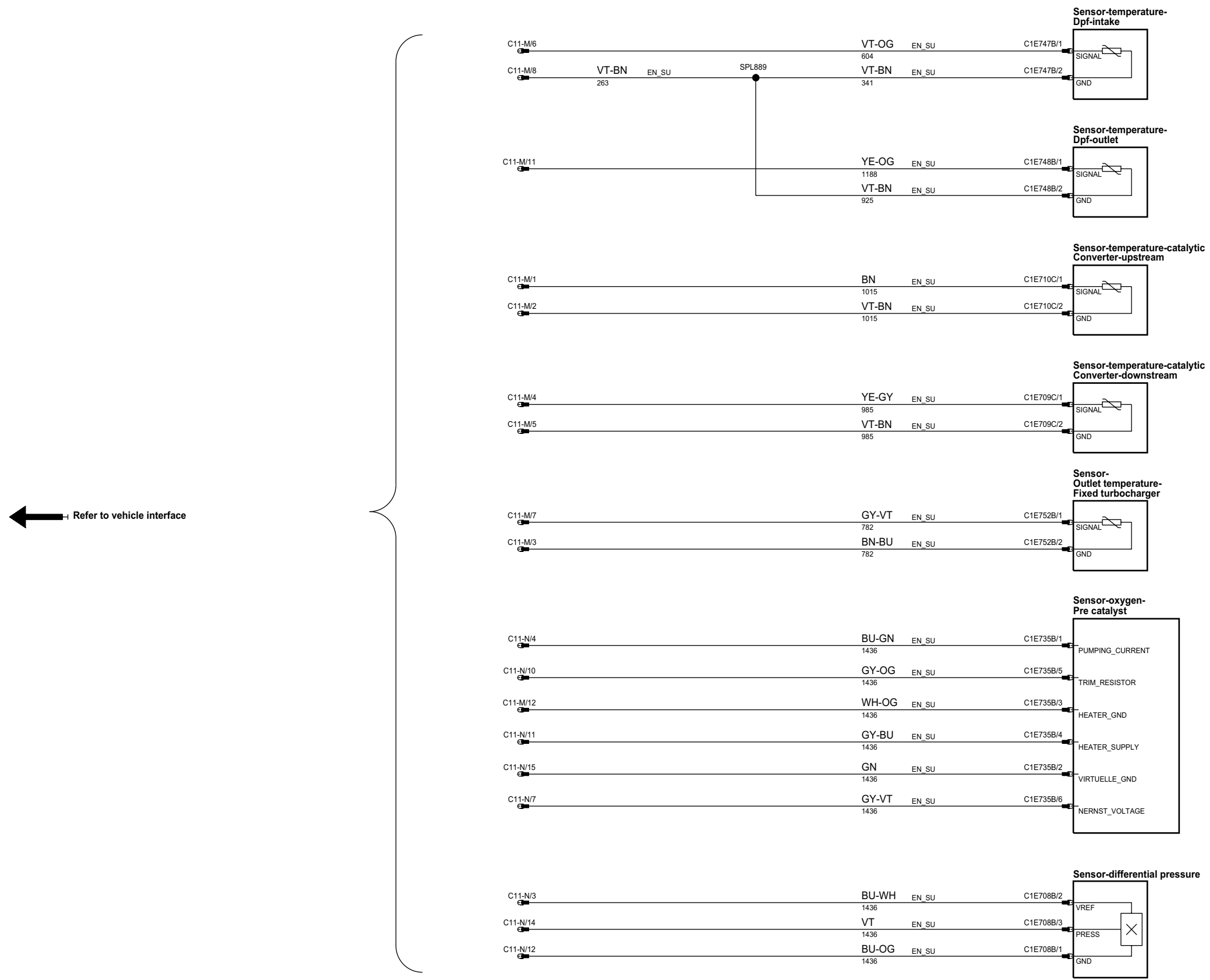

C11-P = C11-A
C11-N = C11-B
C11-M = C11-C

phcw93-70041-a-a3

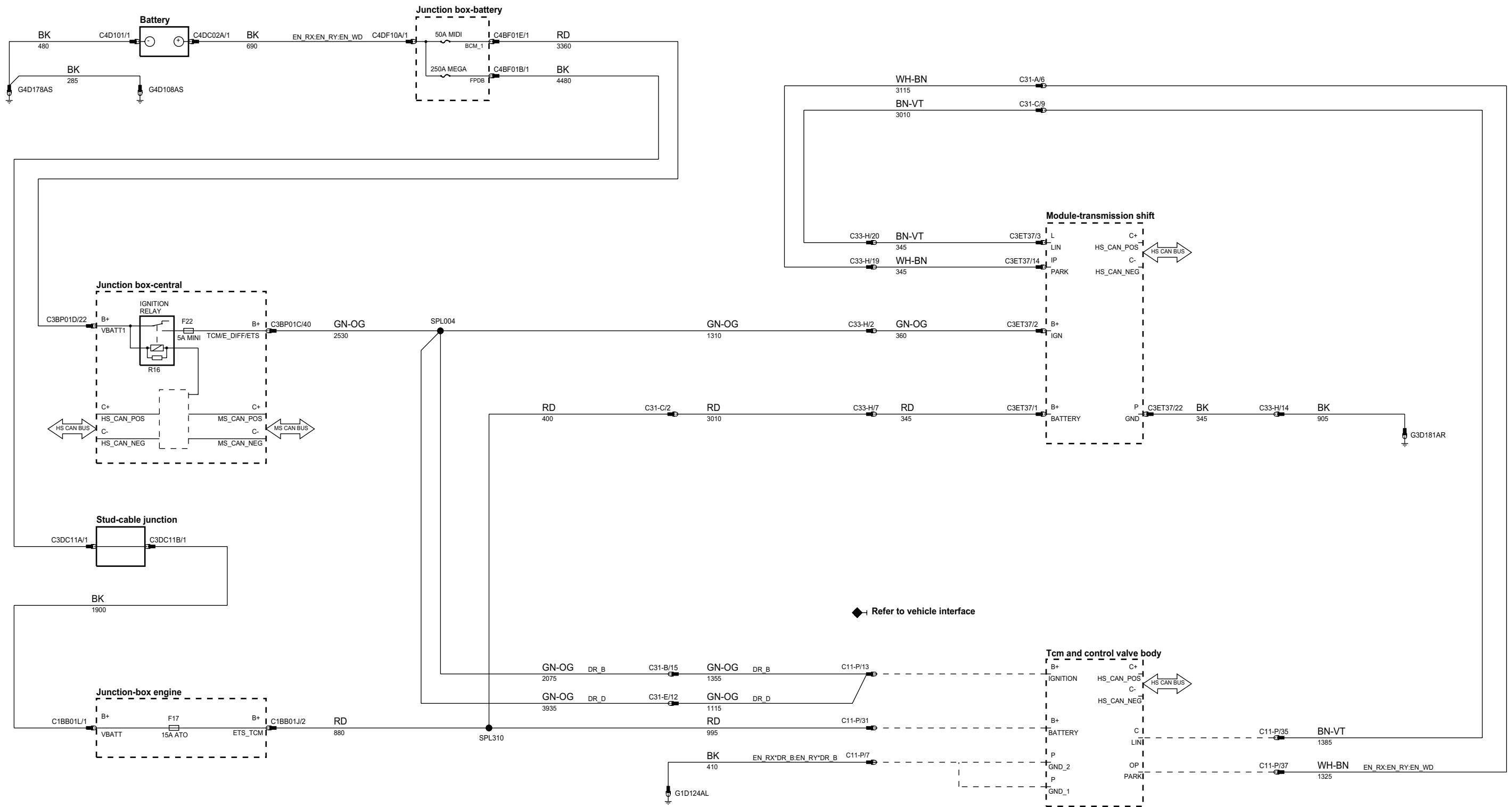

phcw93-70041-d-a3

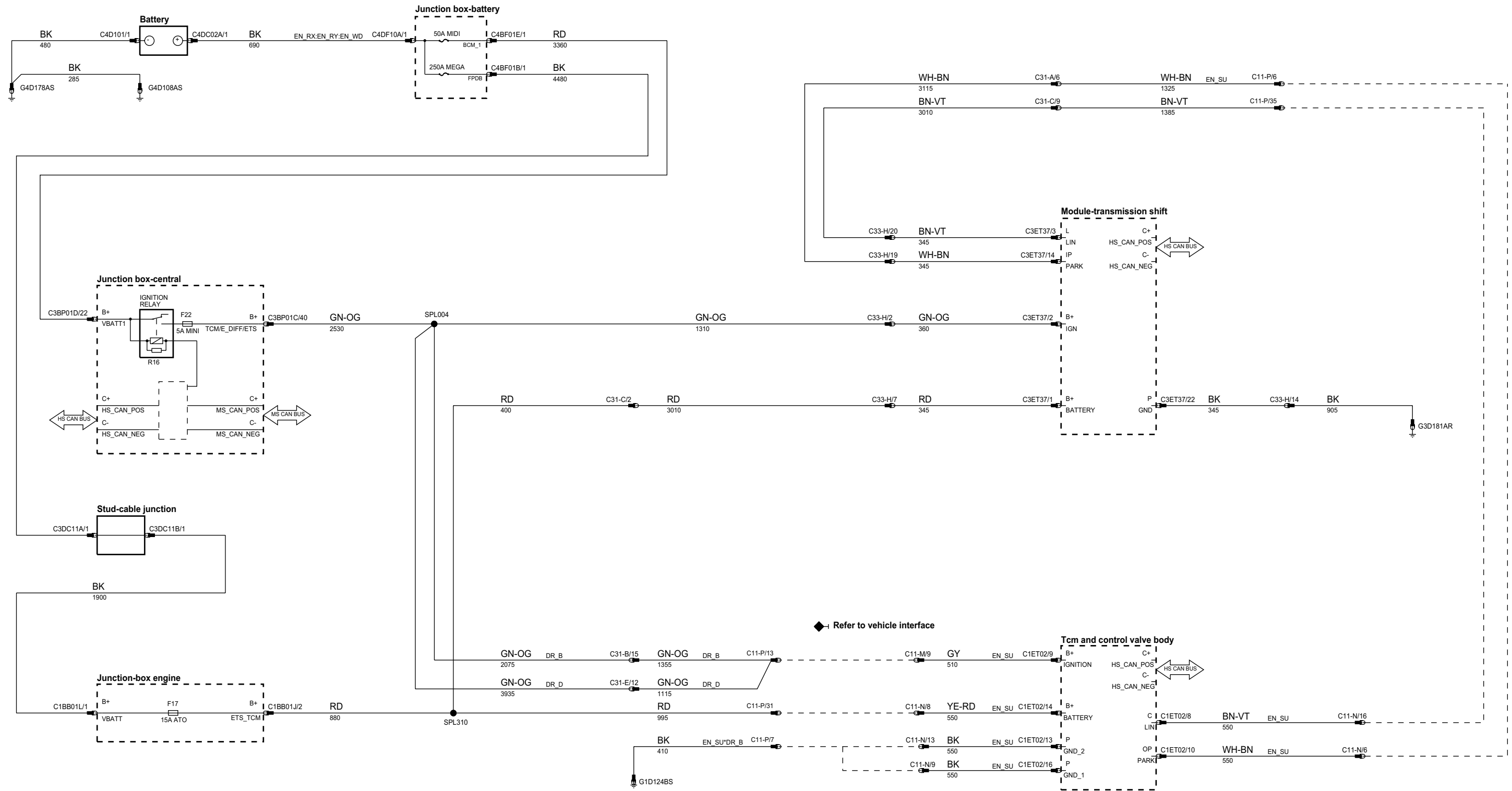

phcw93-70036-a-a3

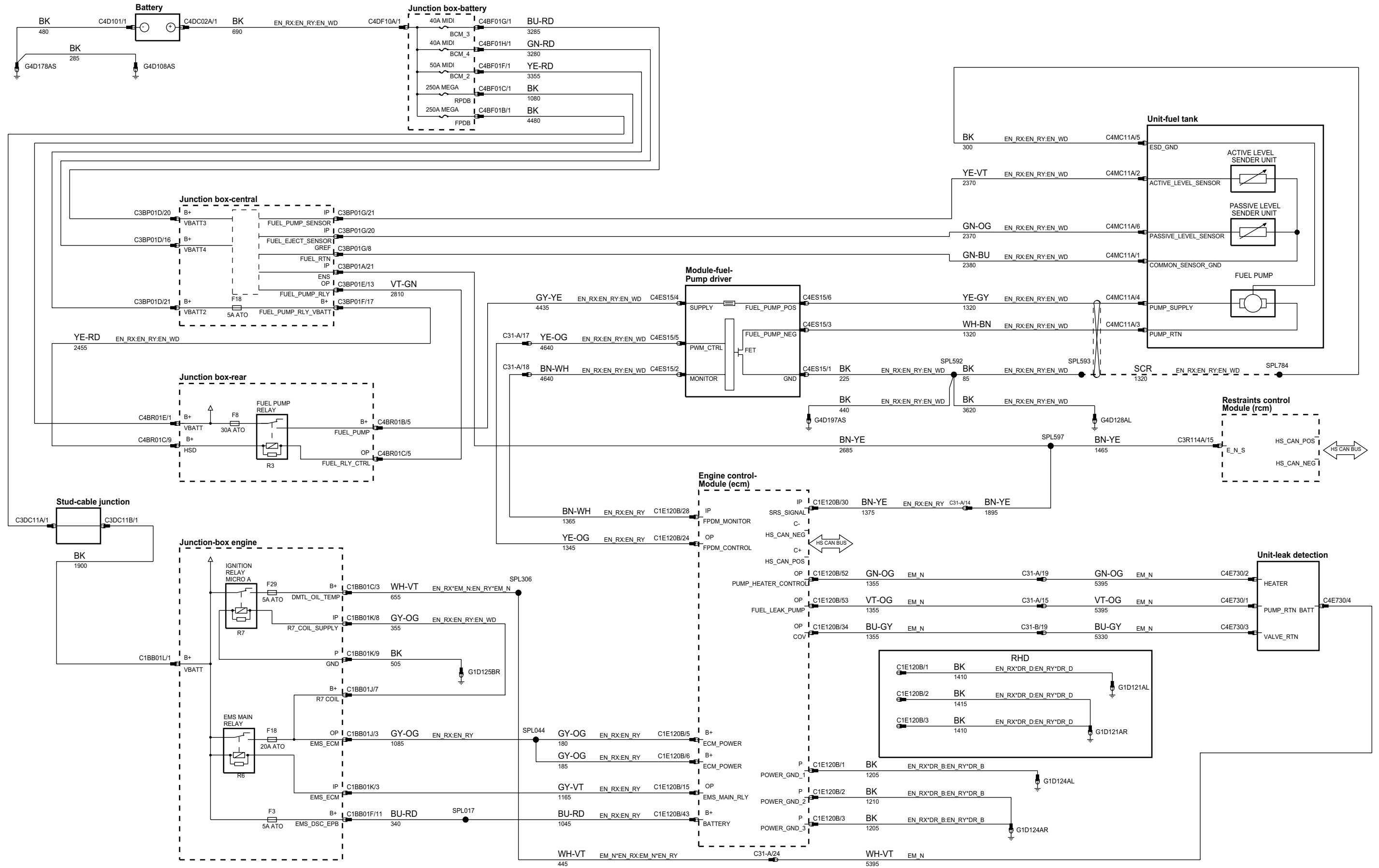

phcw93-70036-d-a3

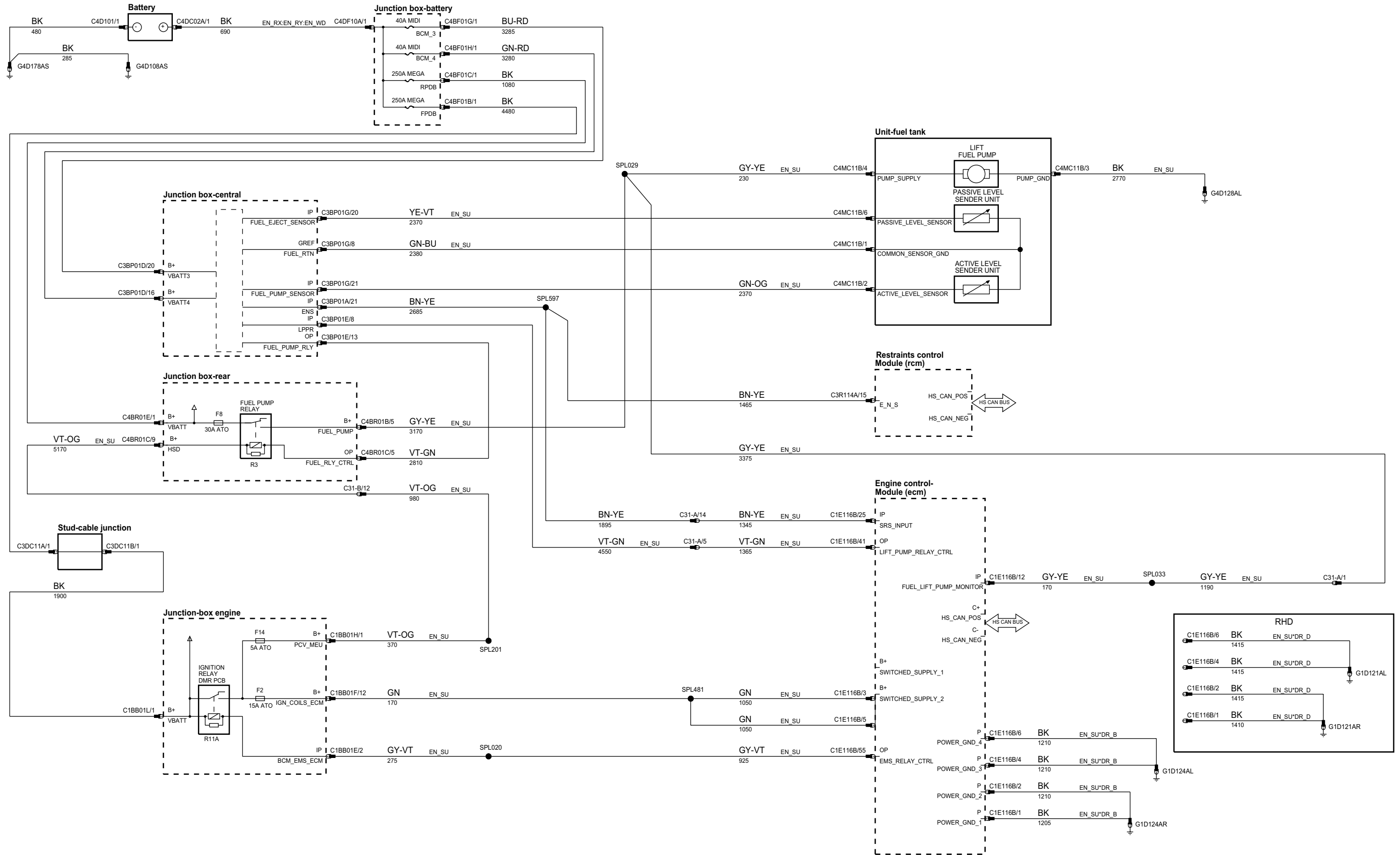

phcw93-70036-d2-a3

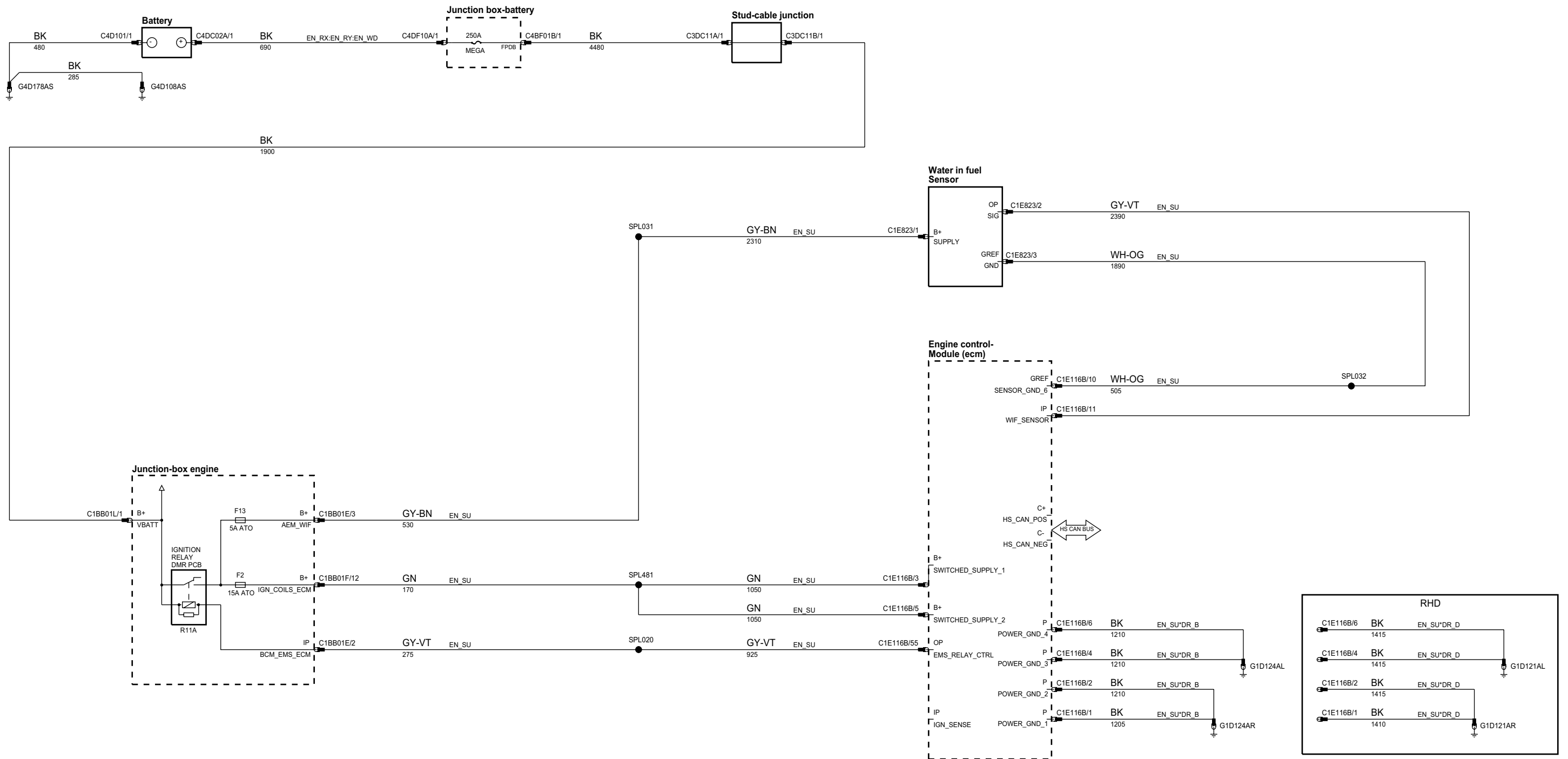

phcw93-70190-a-a3

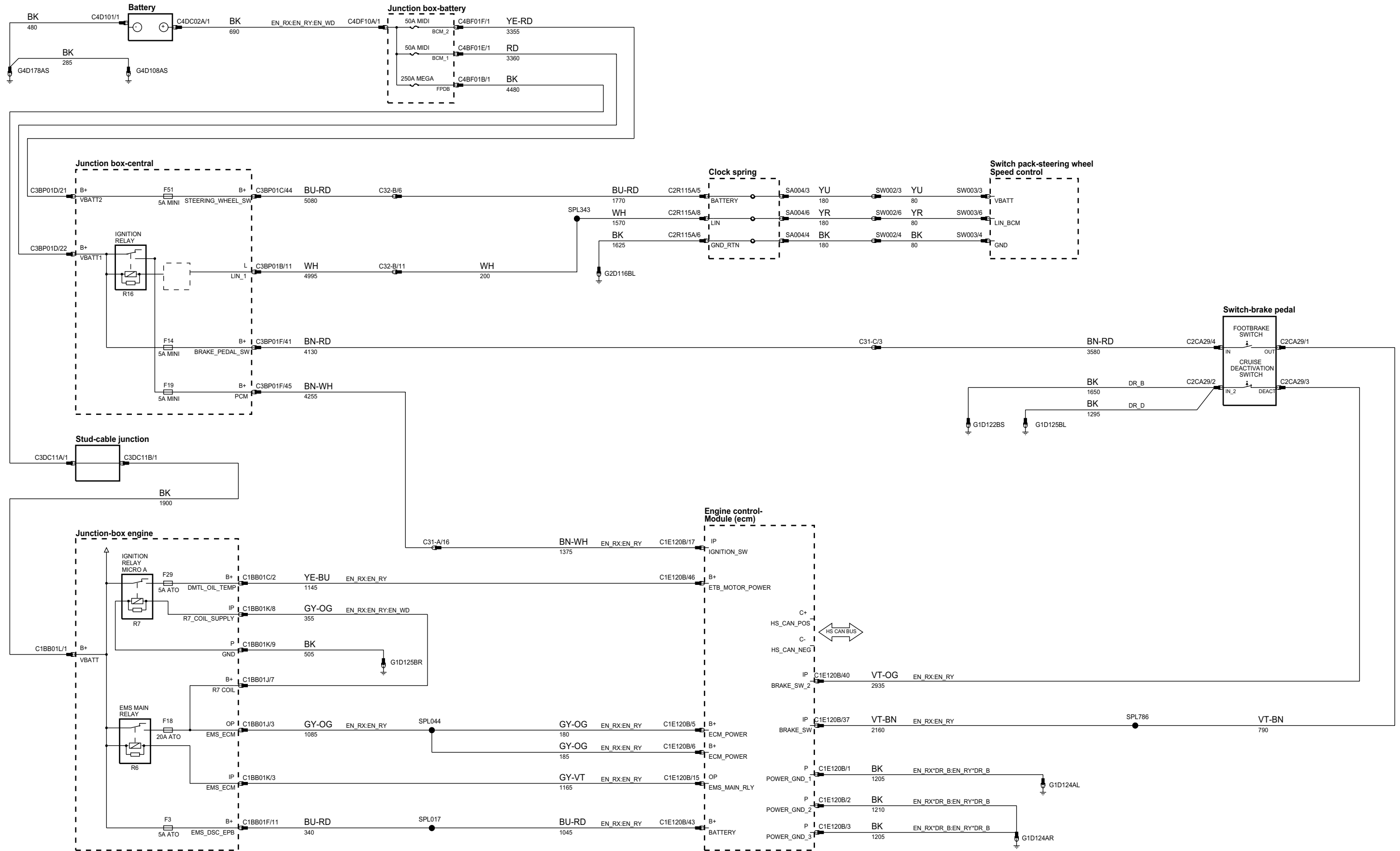

phcw93-70190-d-a3

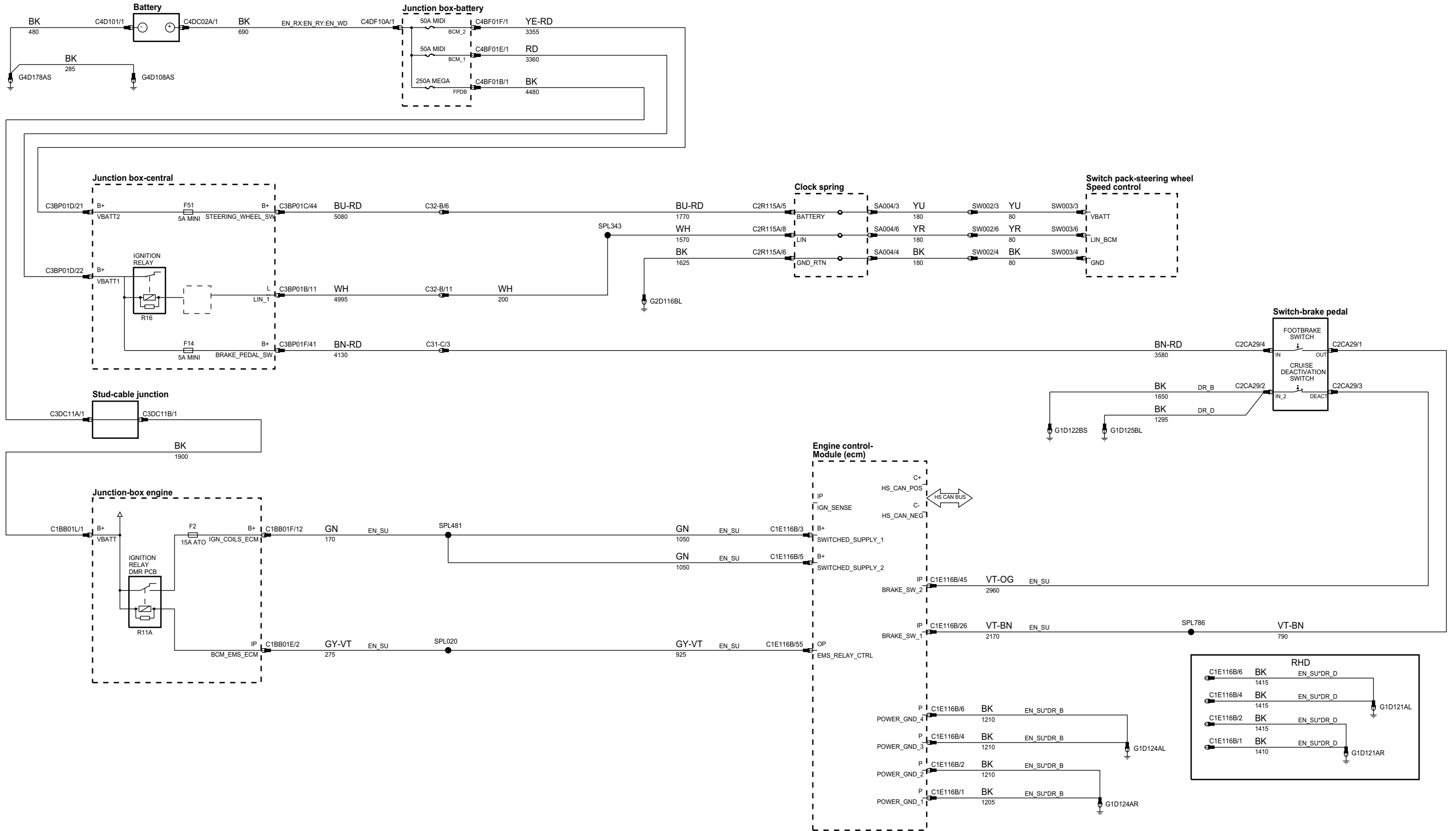

phcw93-70486-a-a3

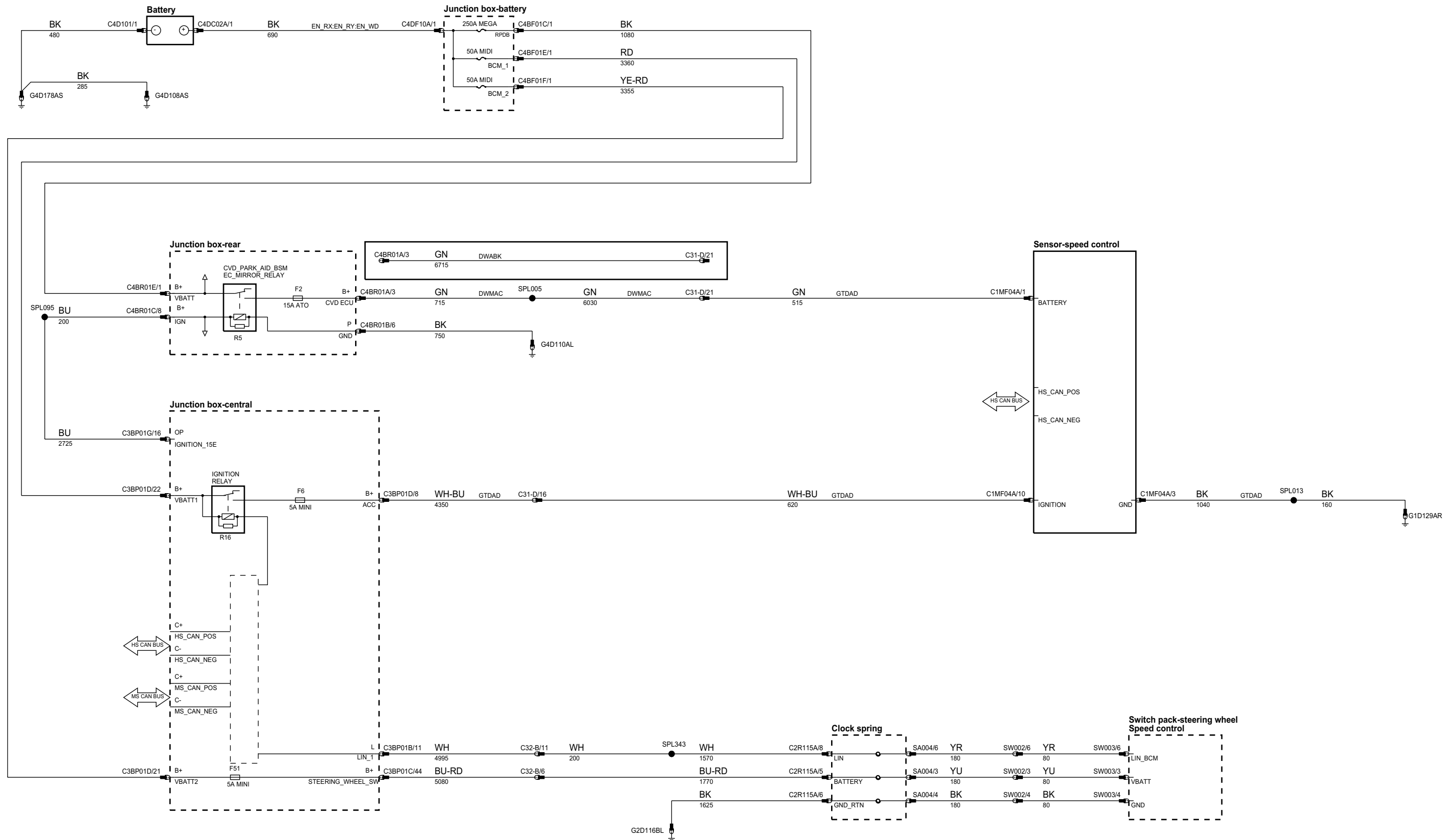

phcw93-70295-a-a3

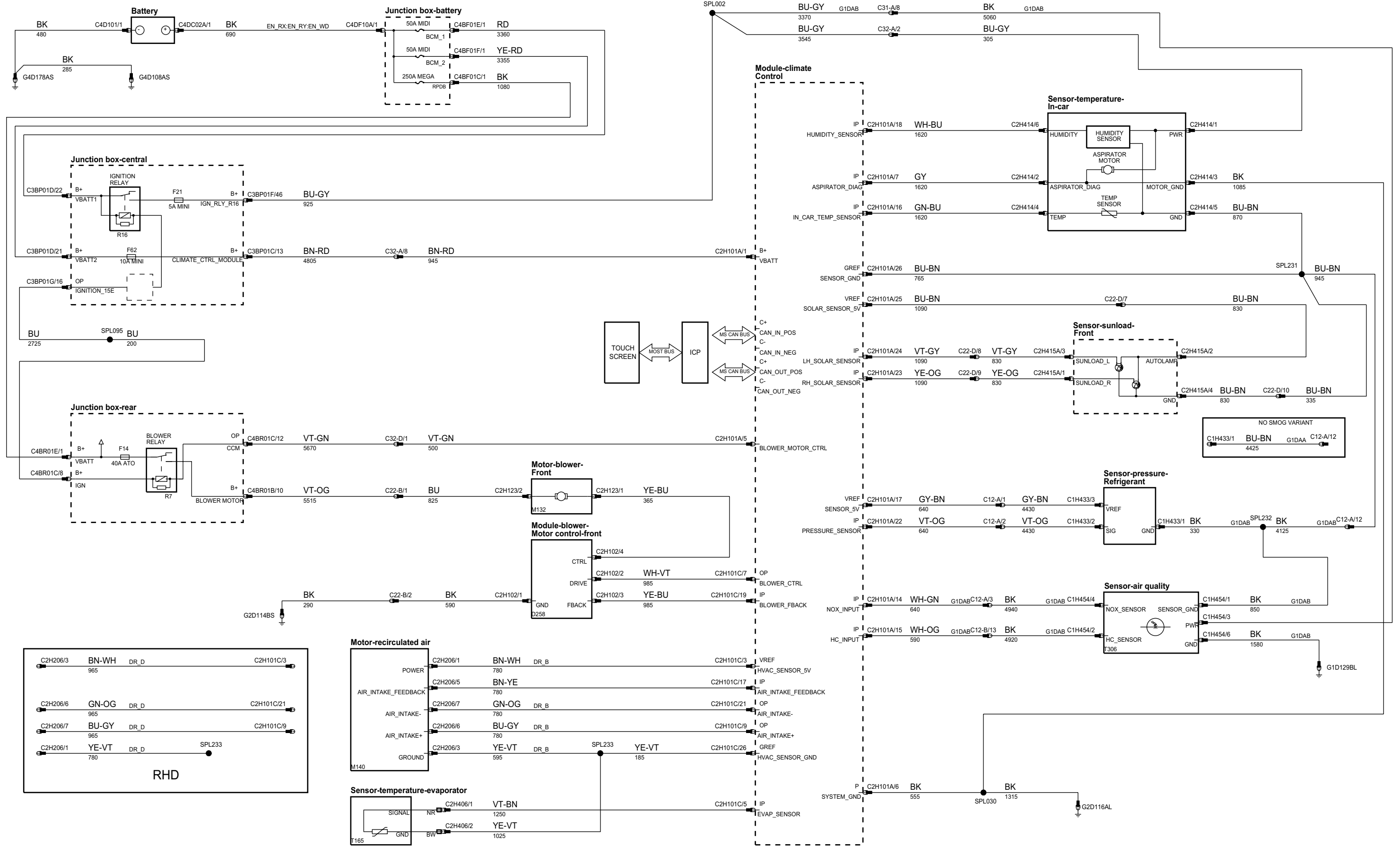

phcw93-70295-b-a3

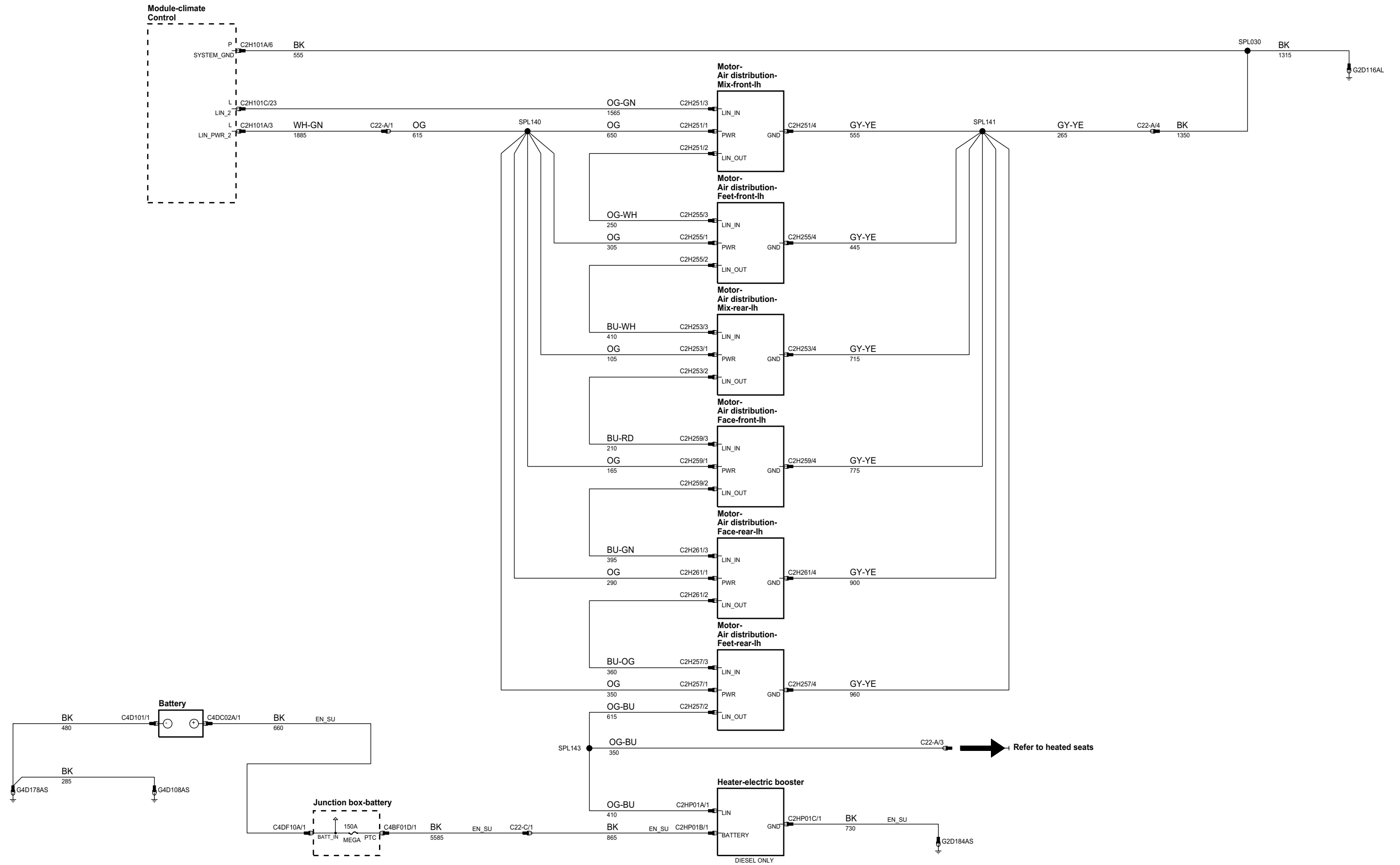

phcw93-70295-c-a3

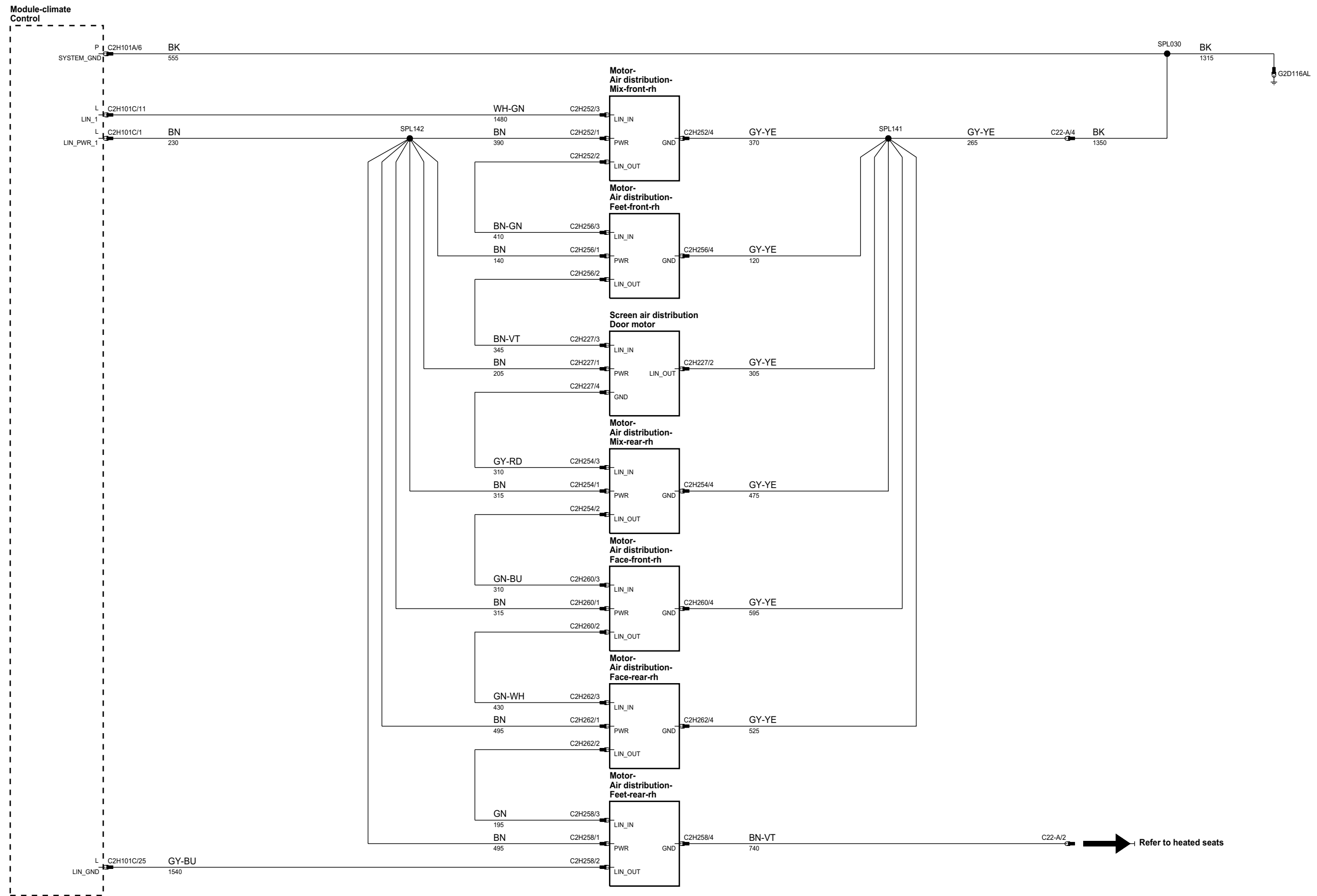

phcw93-70295-d-a3

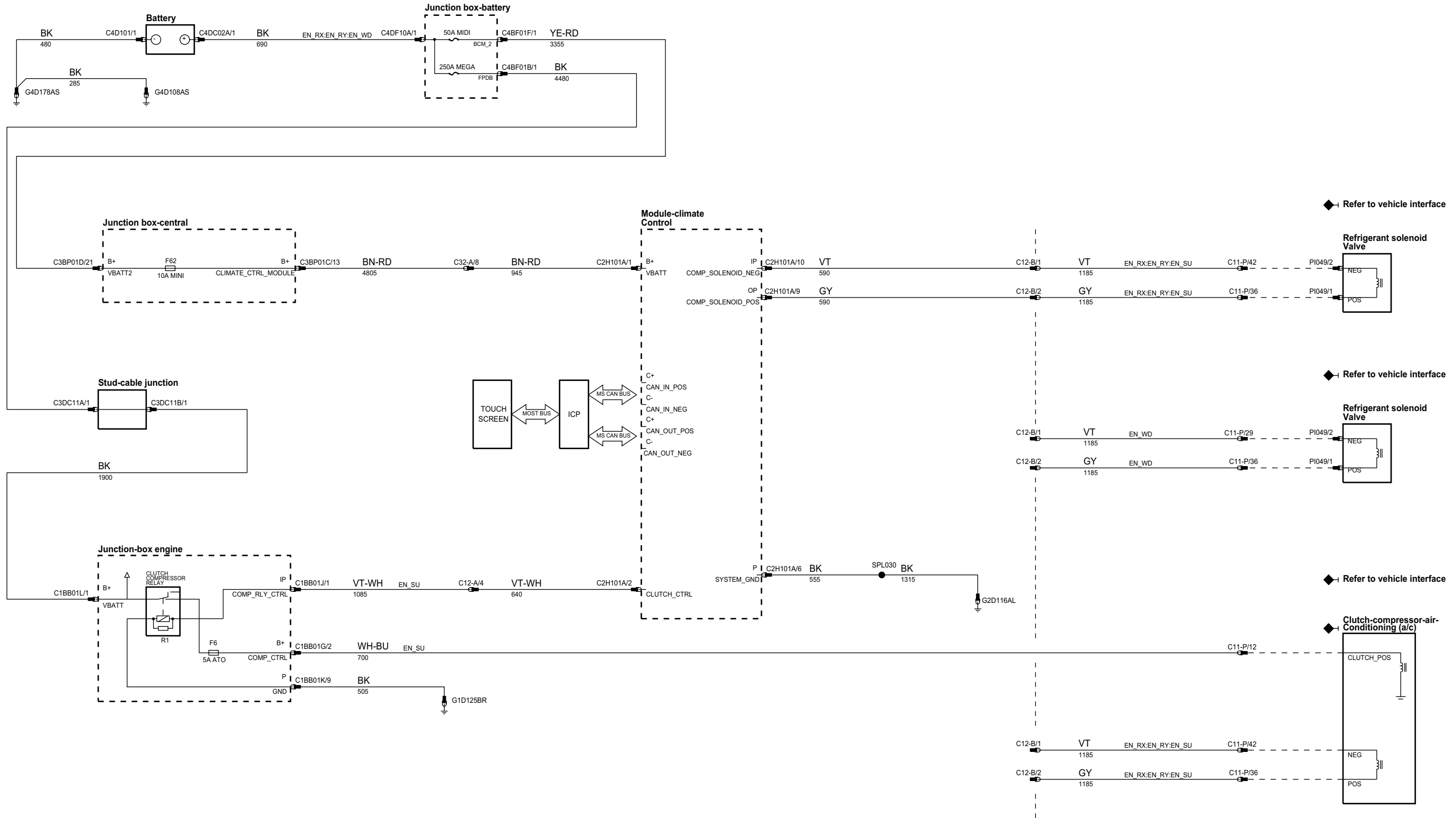

phcw93-70295-e-a3

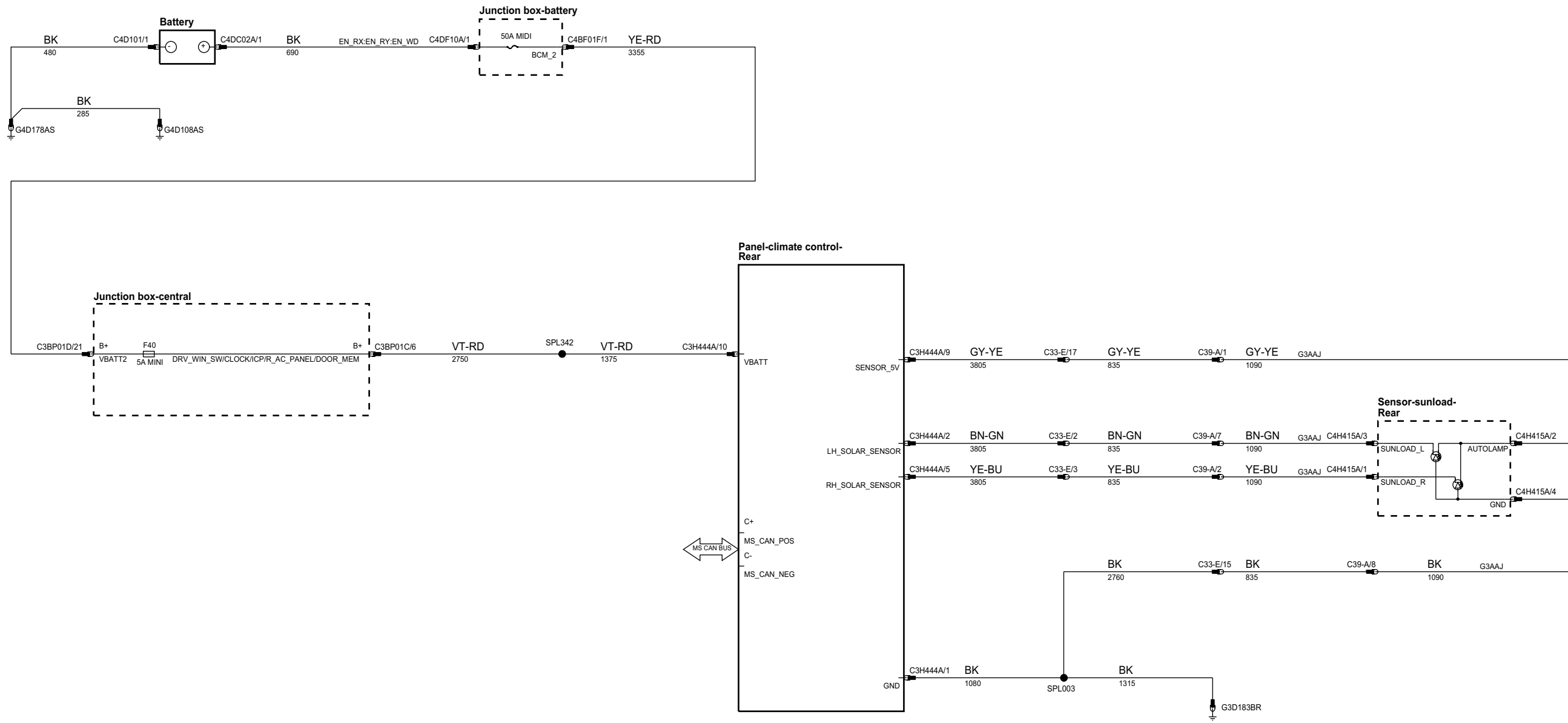

412-02 - AUXILIARY CLIMATE CONTROL

phcw93-70131-a-a3

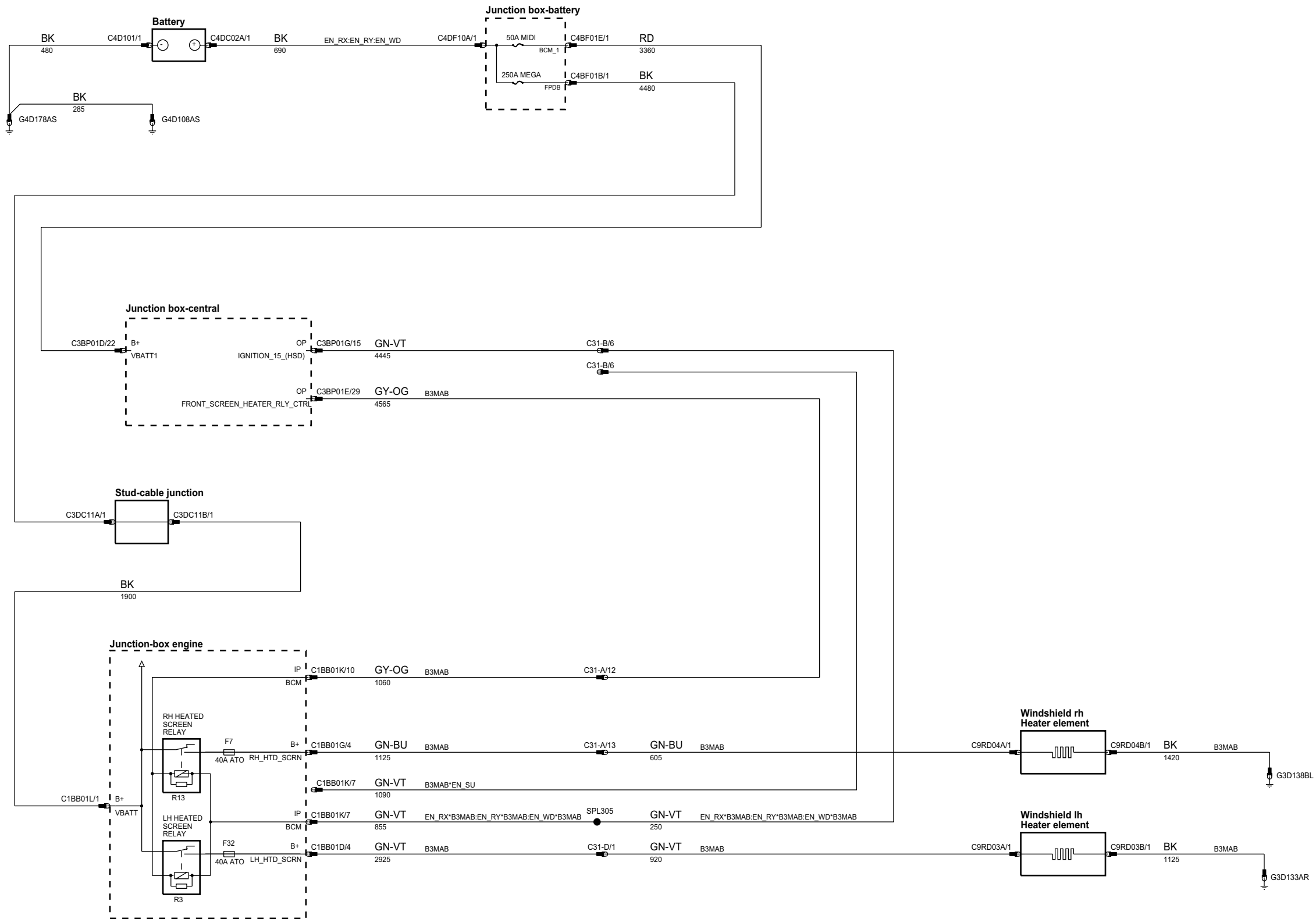

x

412-02 - AUXILIARY CLIMATE CONTROL

phcw93-70132-a-a3

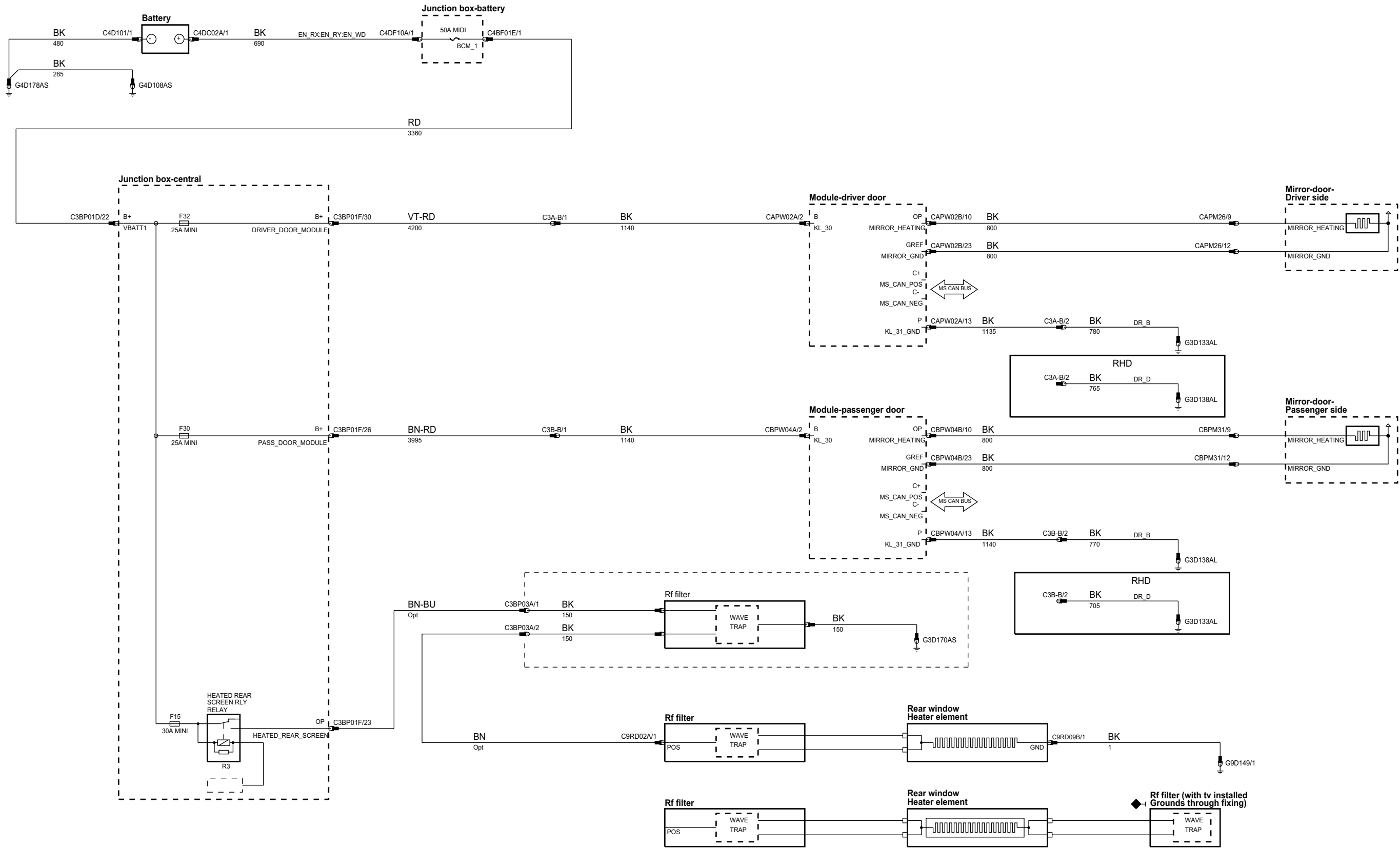

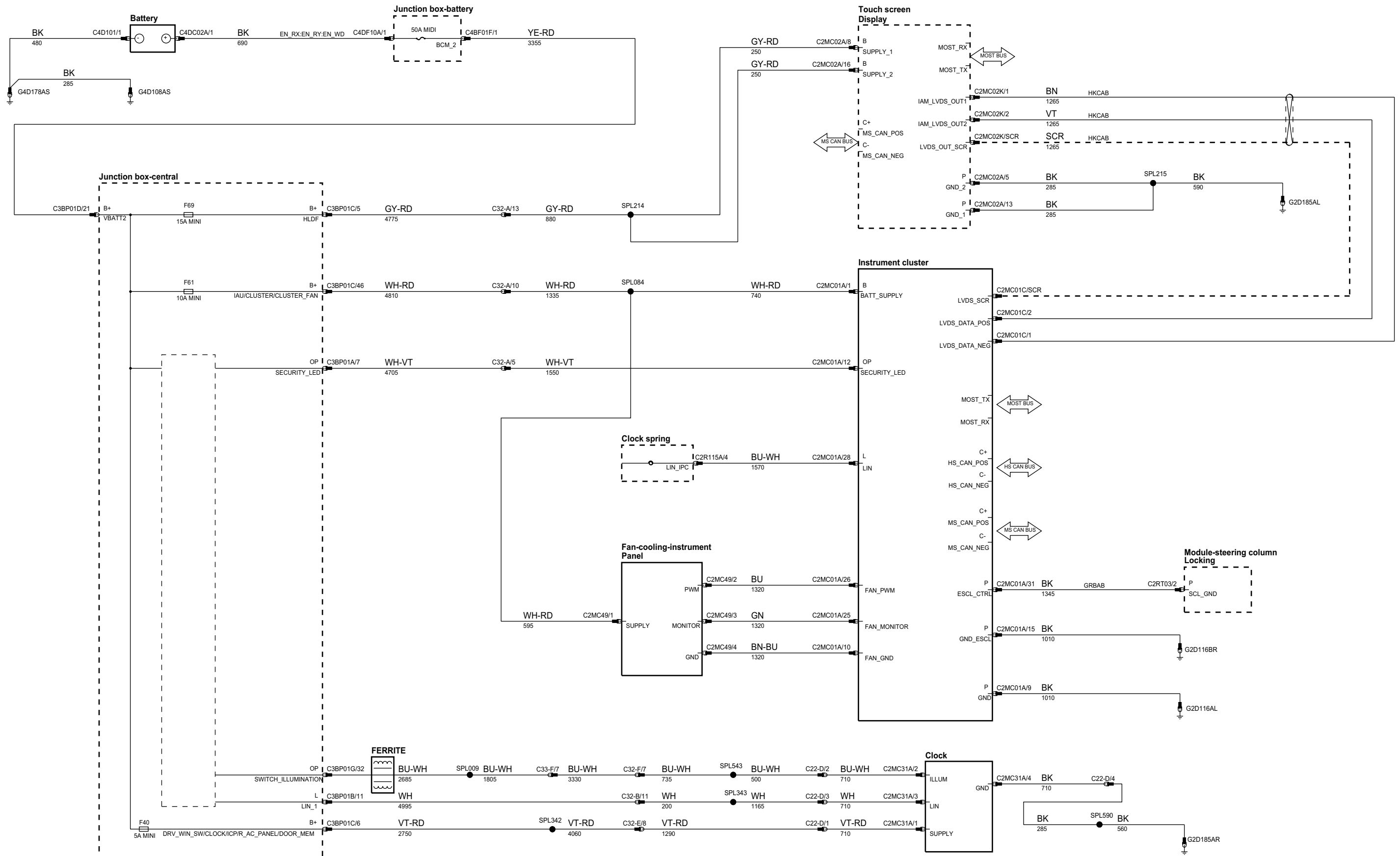

phcw93-70481-b-a3

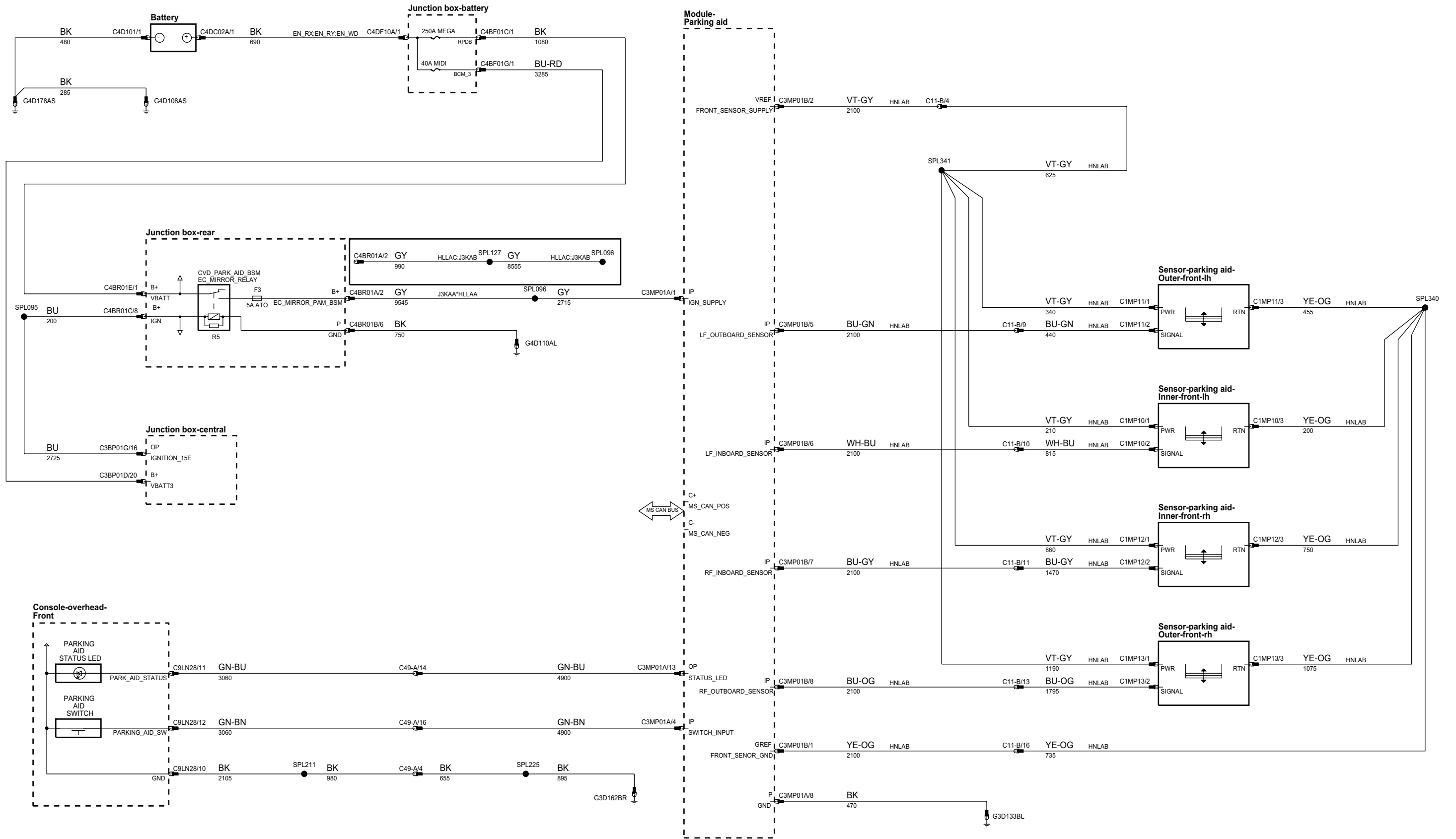

phcw93-70481-a-a3

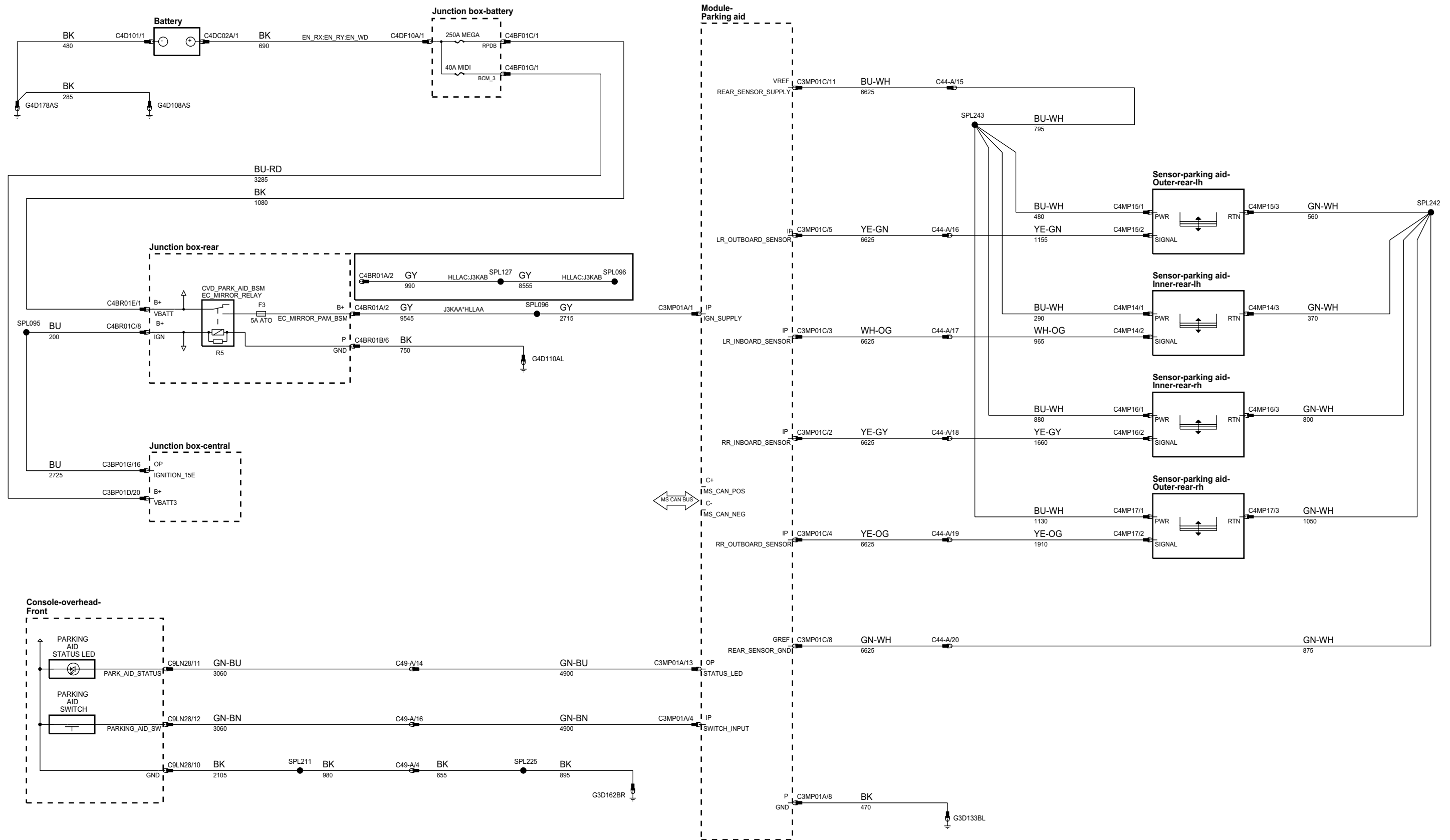

phcw93-70481-c-a3

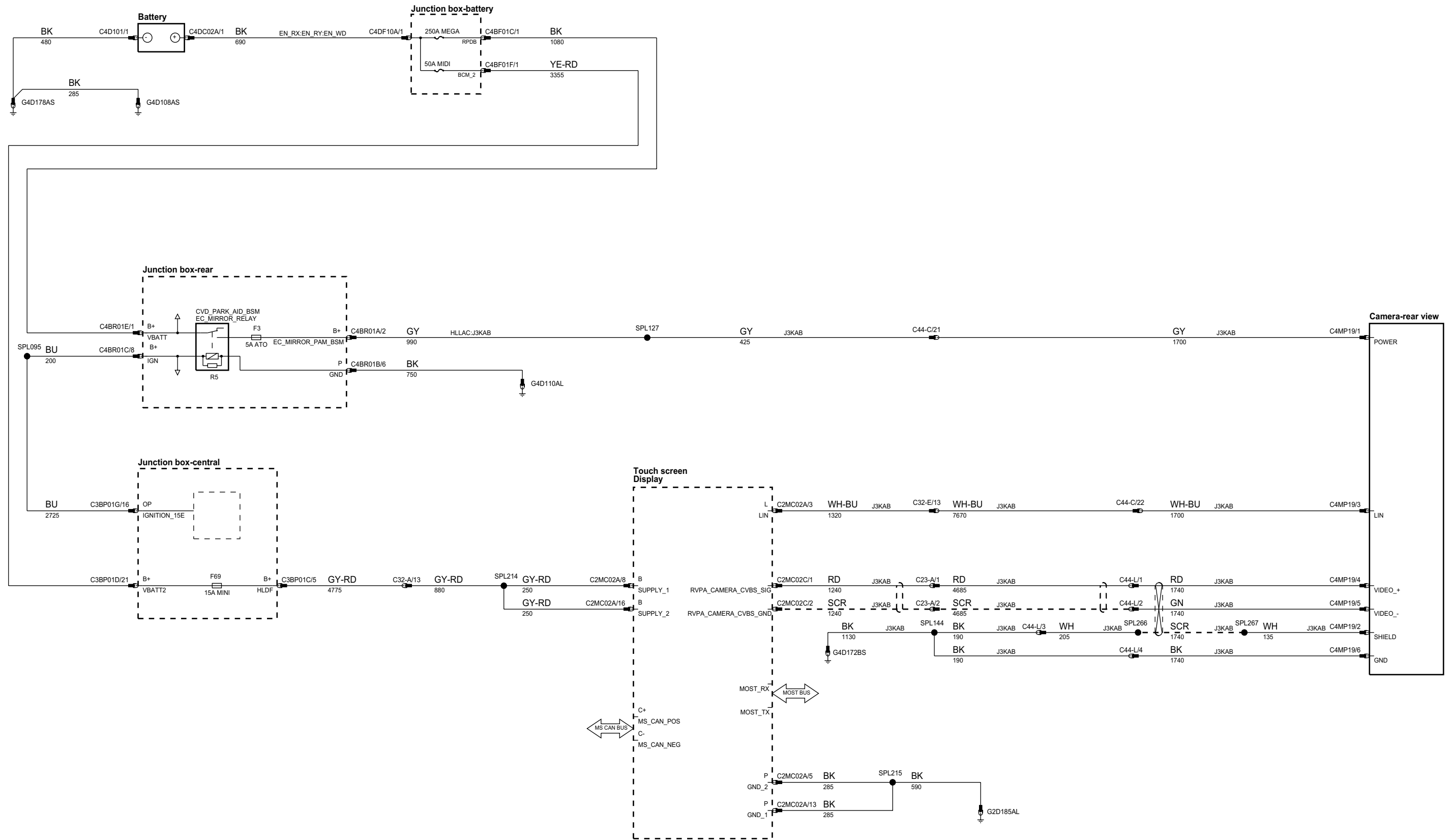

phcw93-70010-e-a3

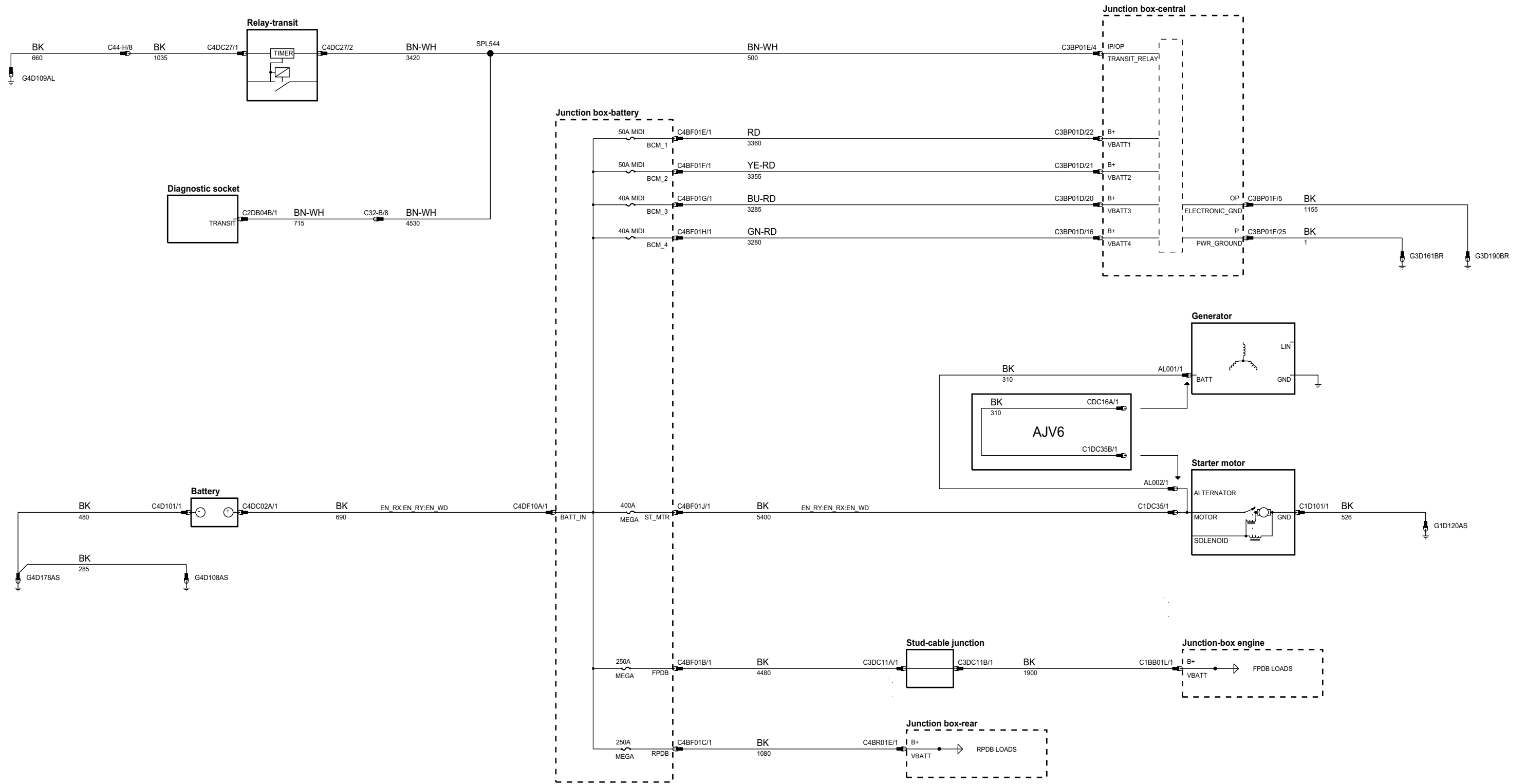

phcw93-70010-b-a3

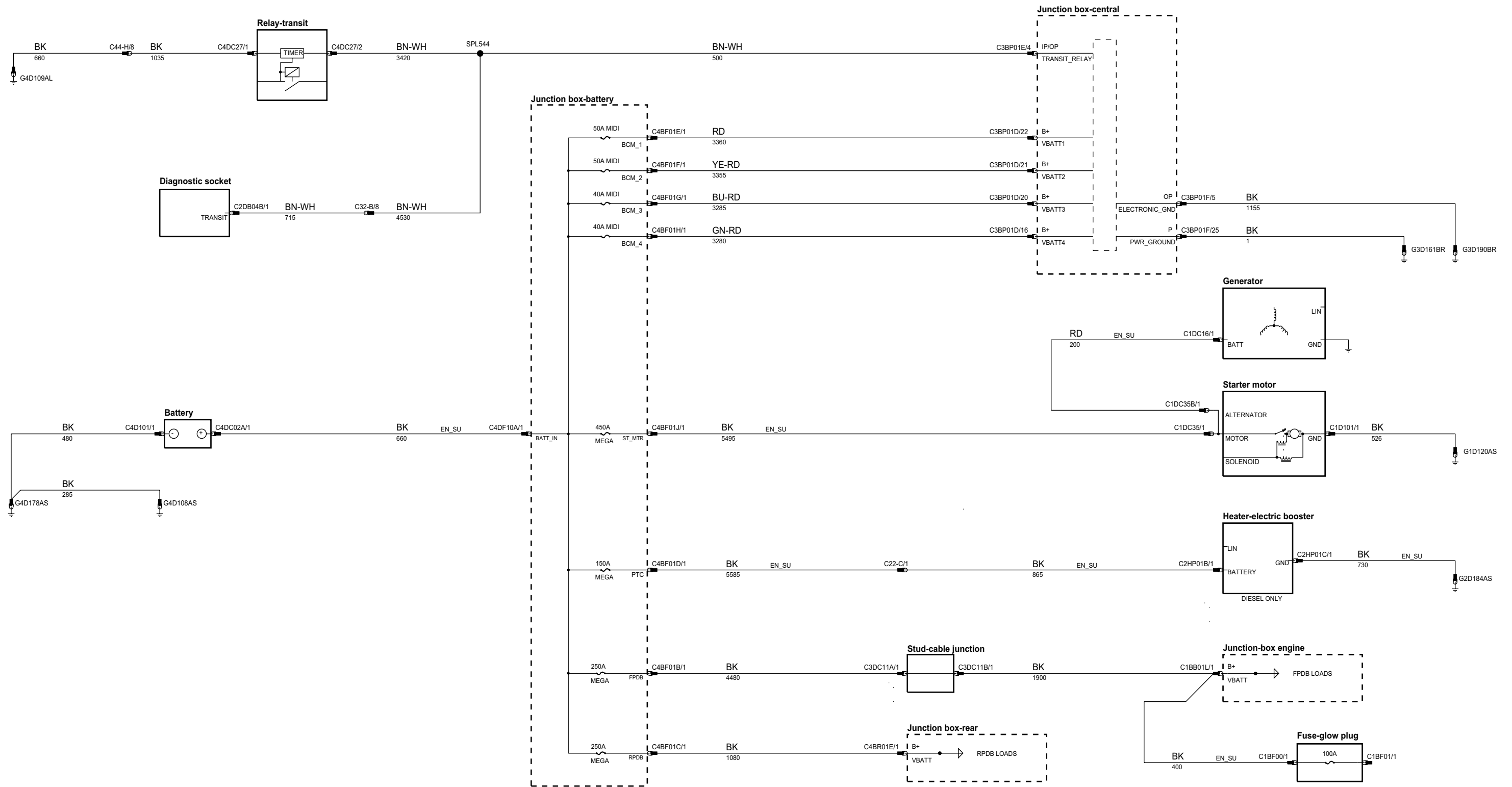

phw93-70010-c-a3

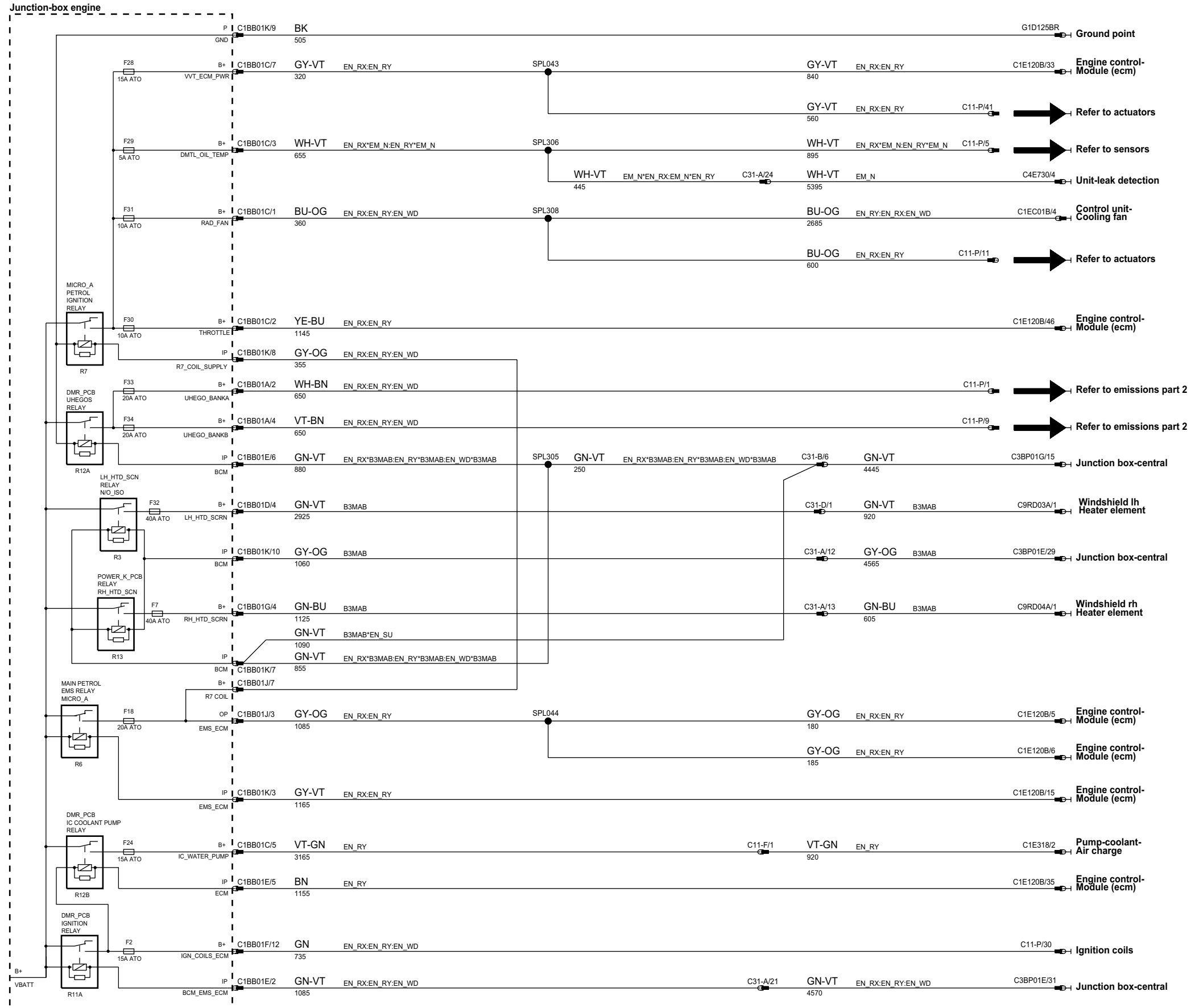

phcw93-70010-e-a3

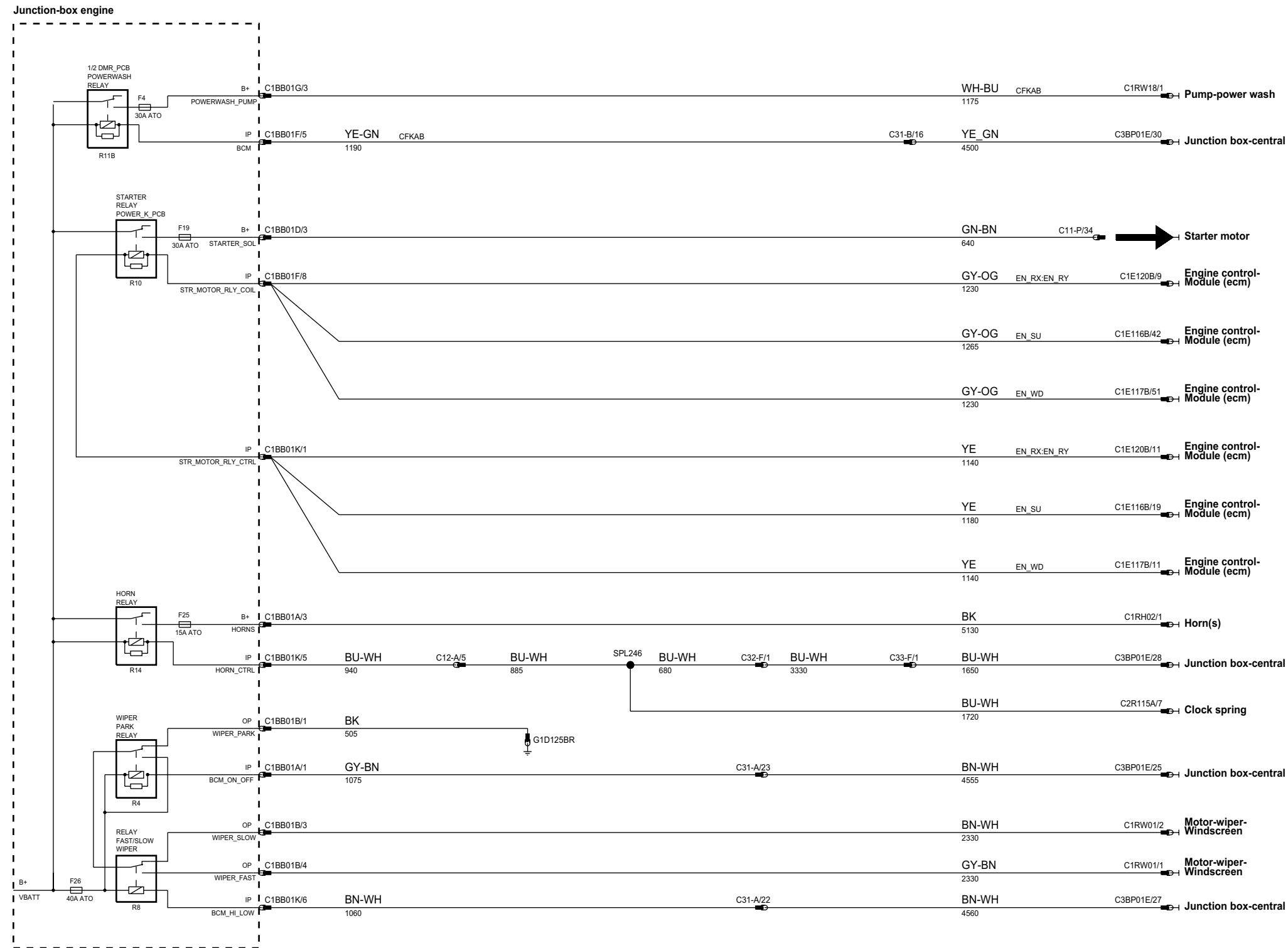

phcw93-70010-d-a3

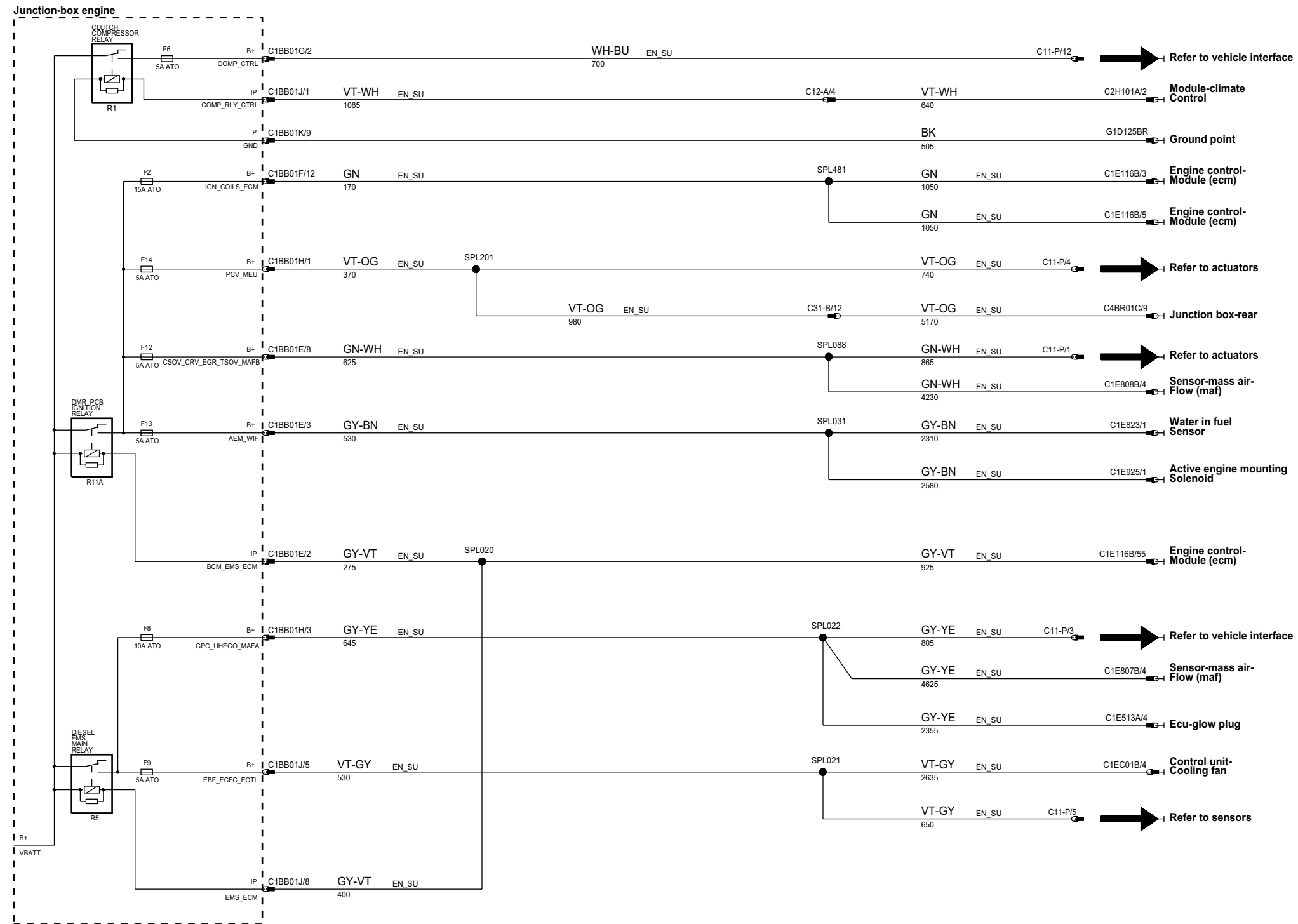

phcw93-70010-f-a3

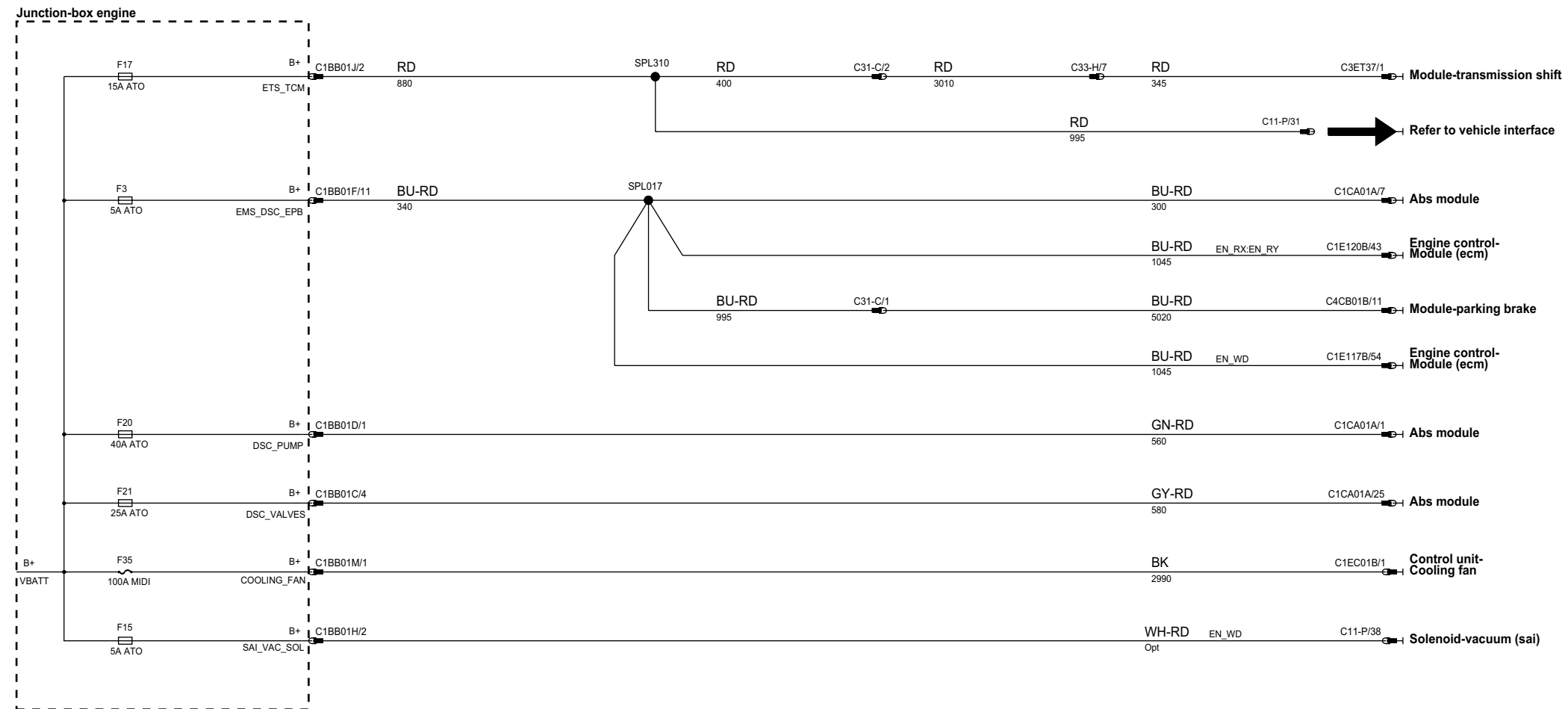

phcw93-70010-k-a3

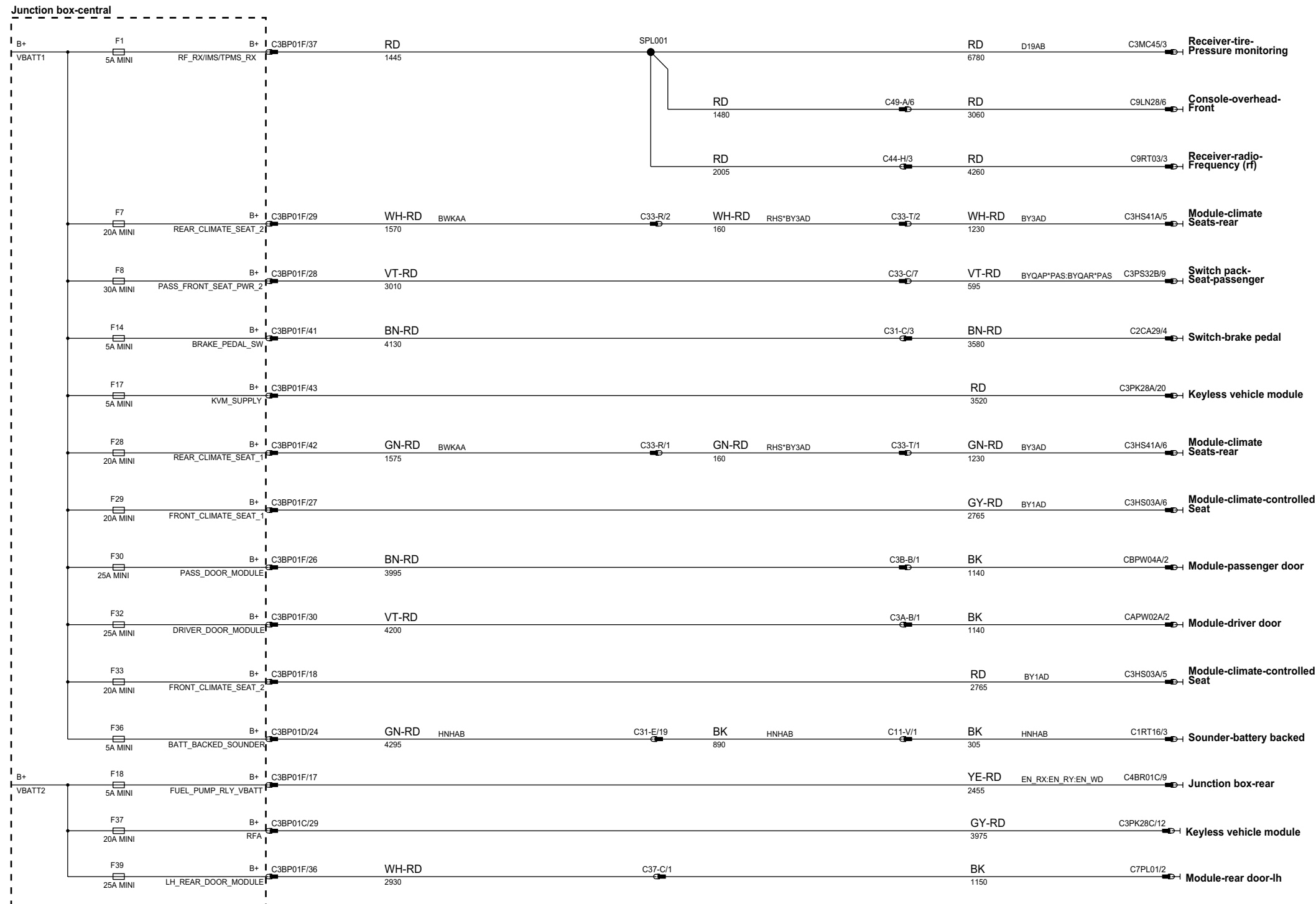

phcw93-70010-a3

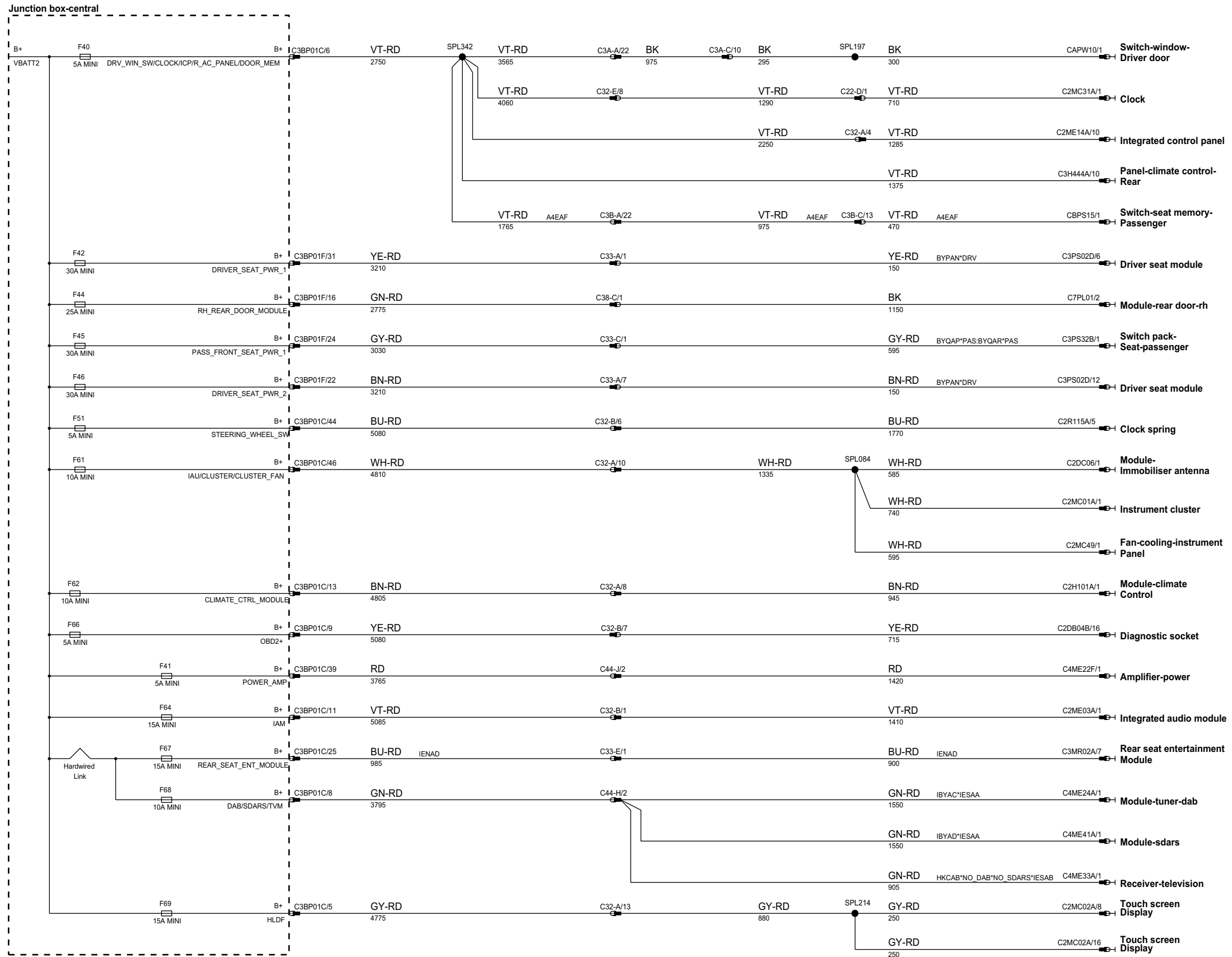

phcw93-70010-m-a3

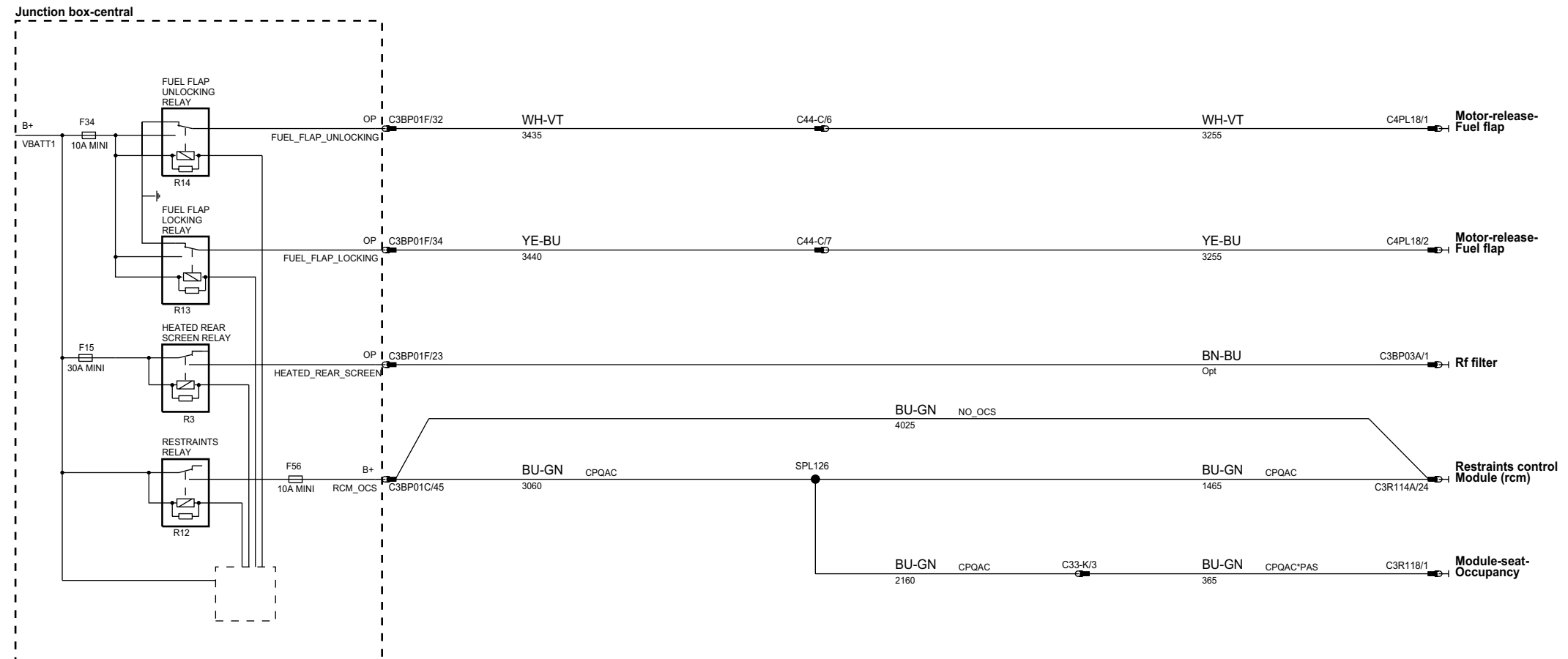

phcw93-70010-n-a3

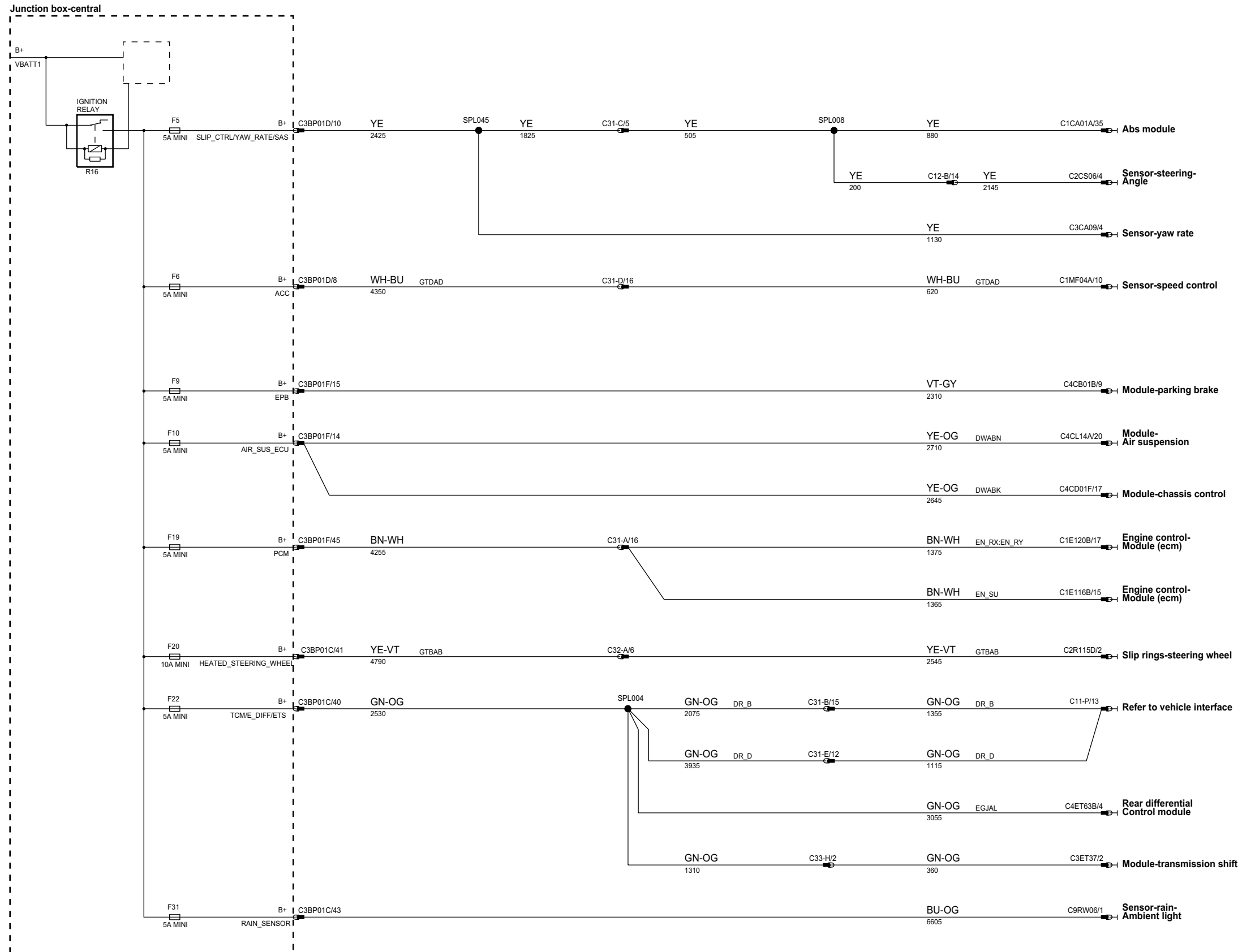

phcw93-70010-p-a3

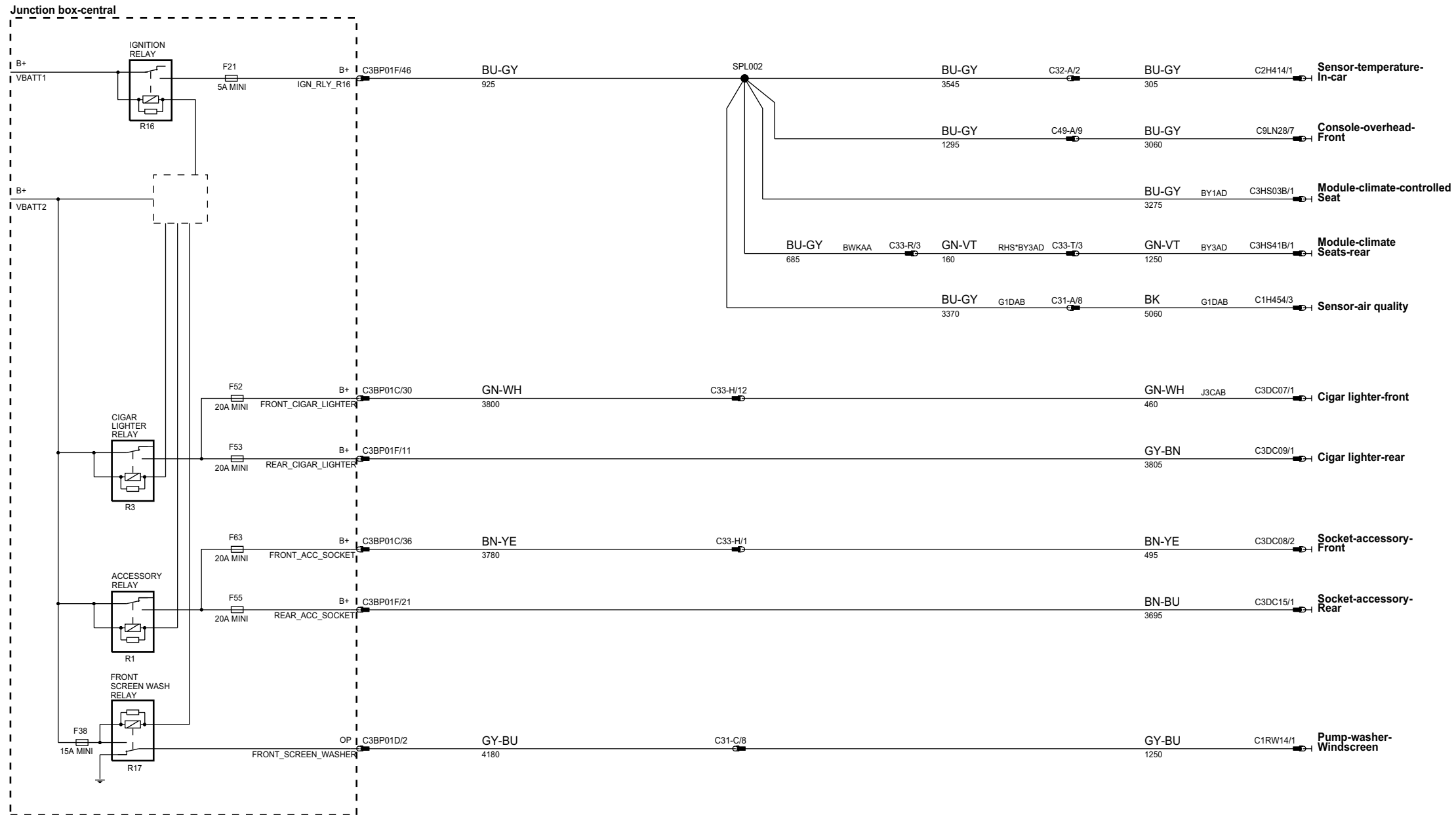

phcw93-70010-r-a3

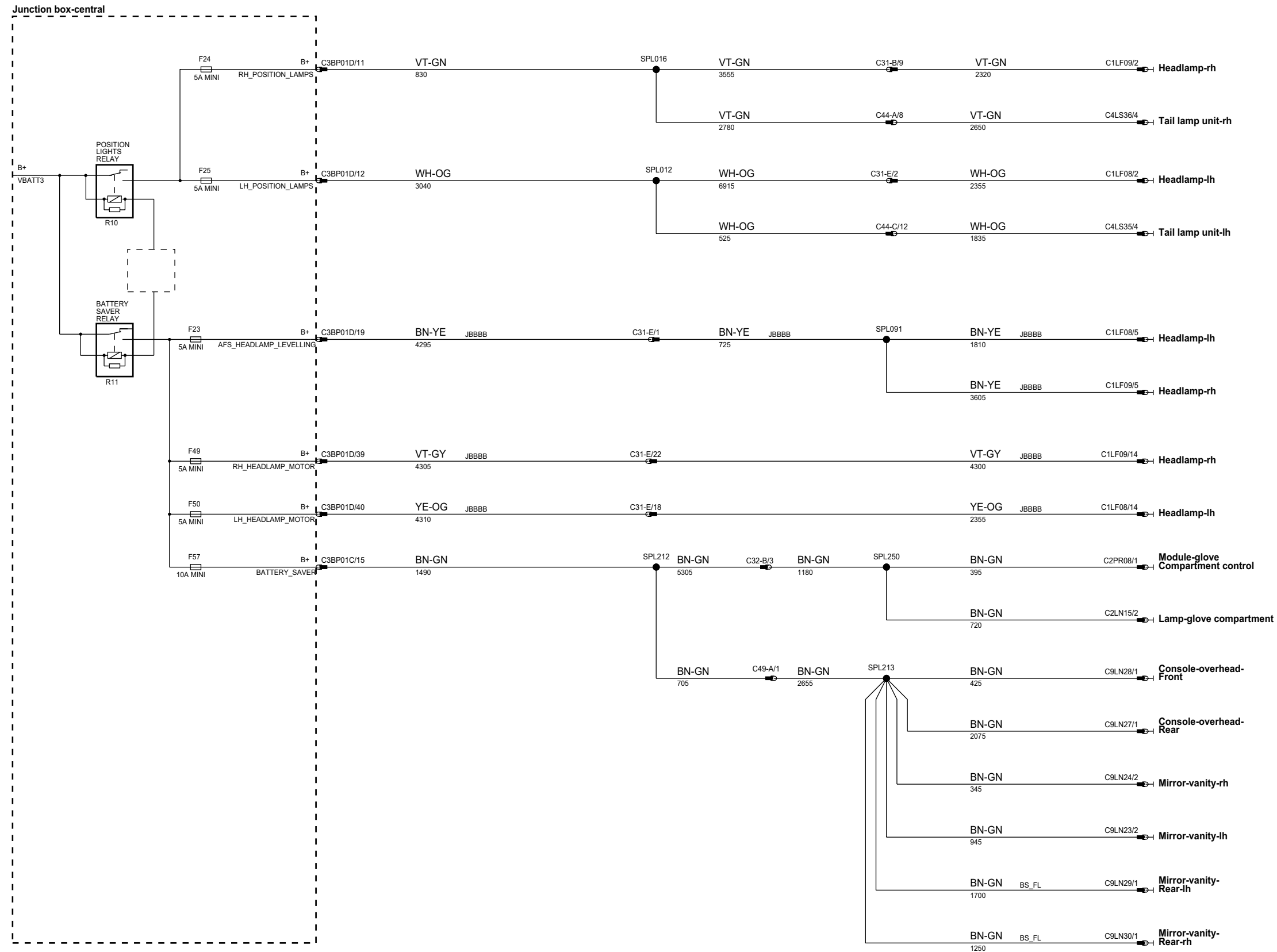

phcw93-70010-s-a3

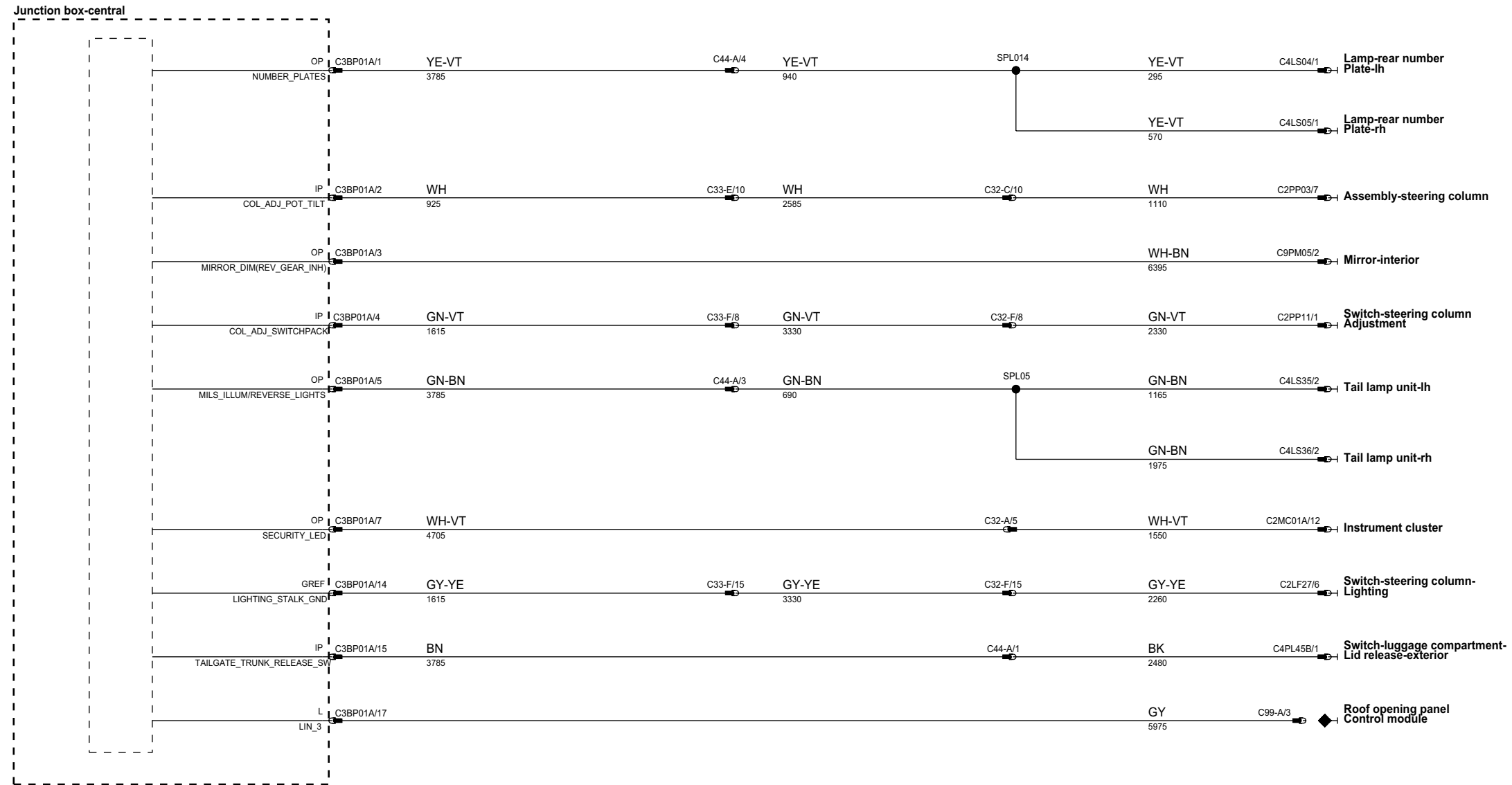

phcw93-70010-1-a3

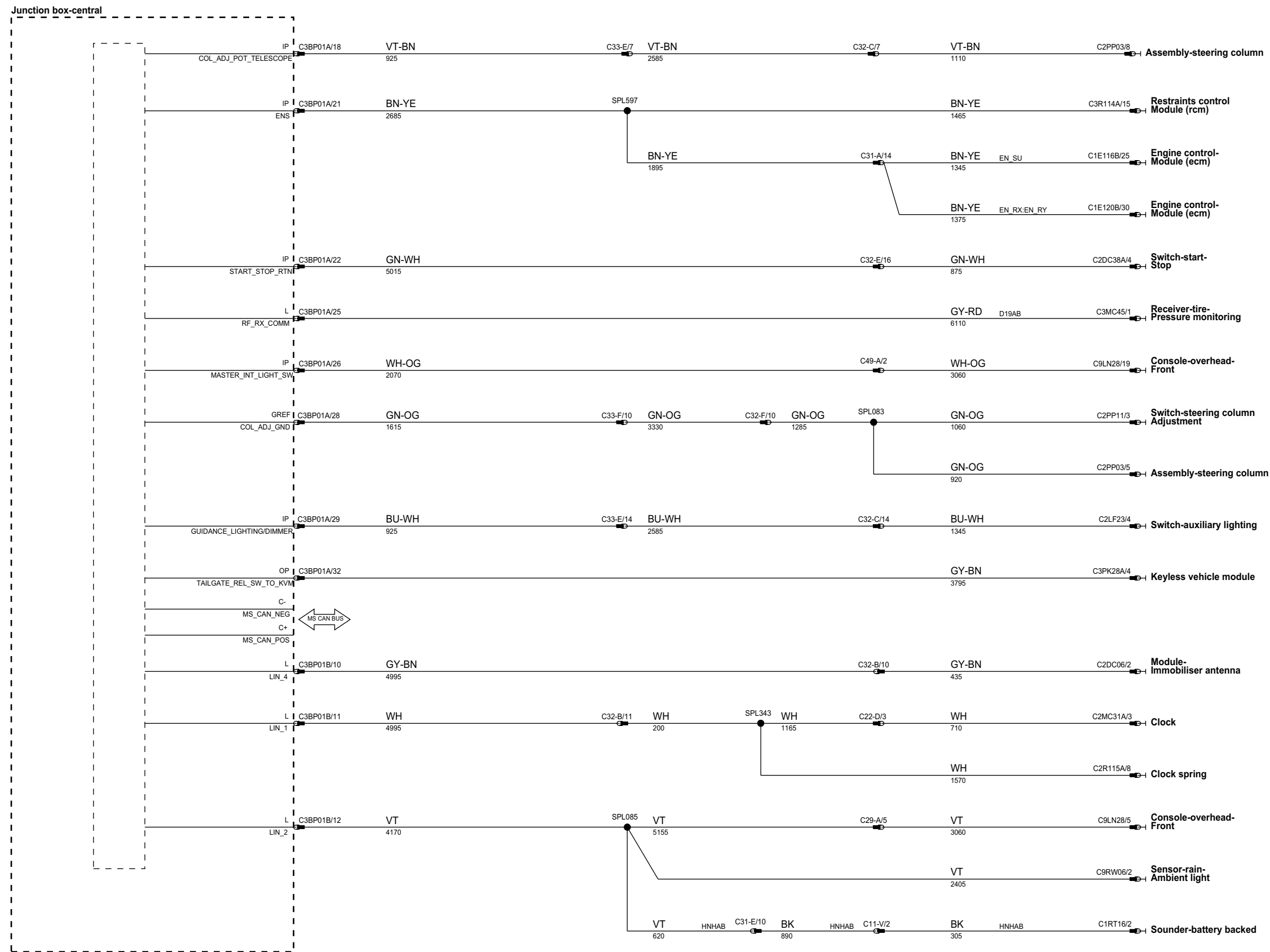

phcw93-70010-u-a3

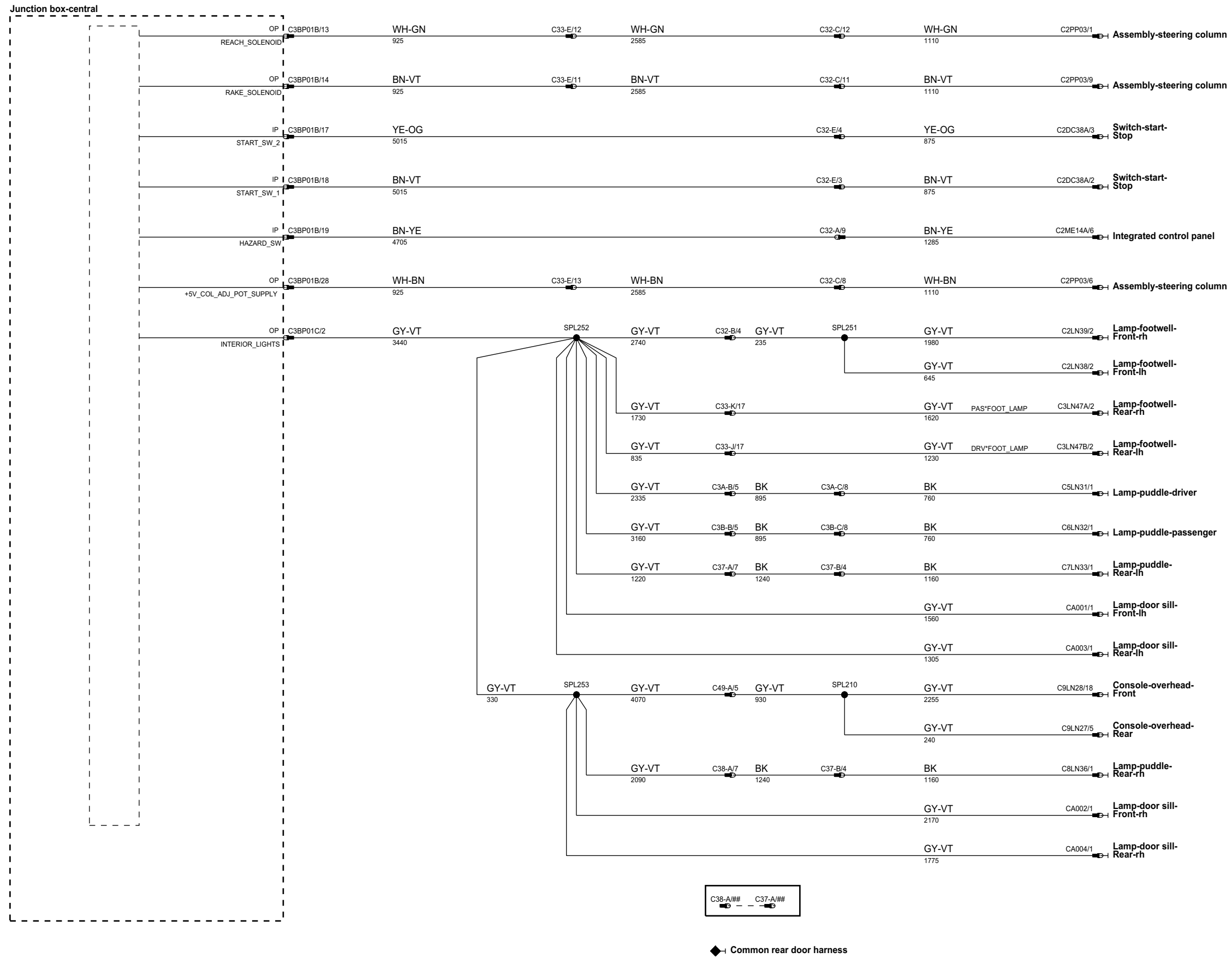

phcw93-70010-v-a3

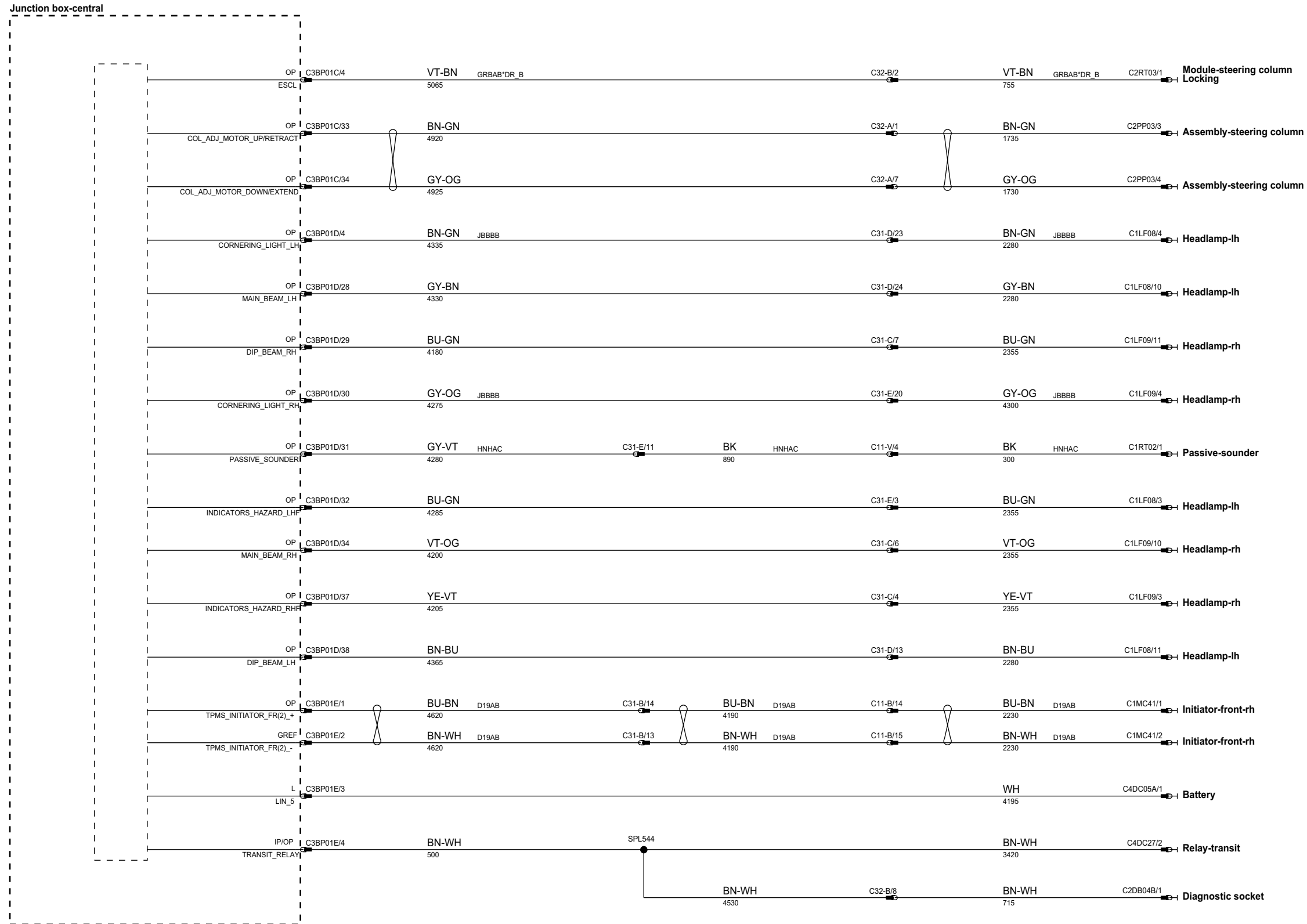

phcw93-70010-y-a3

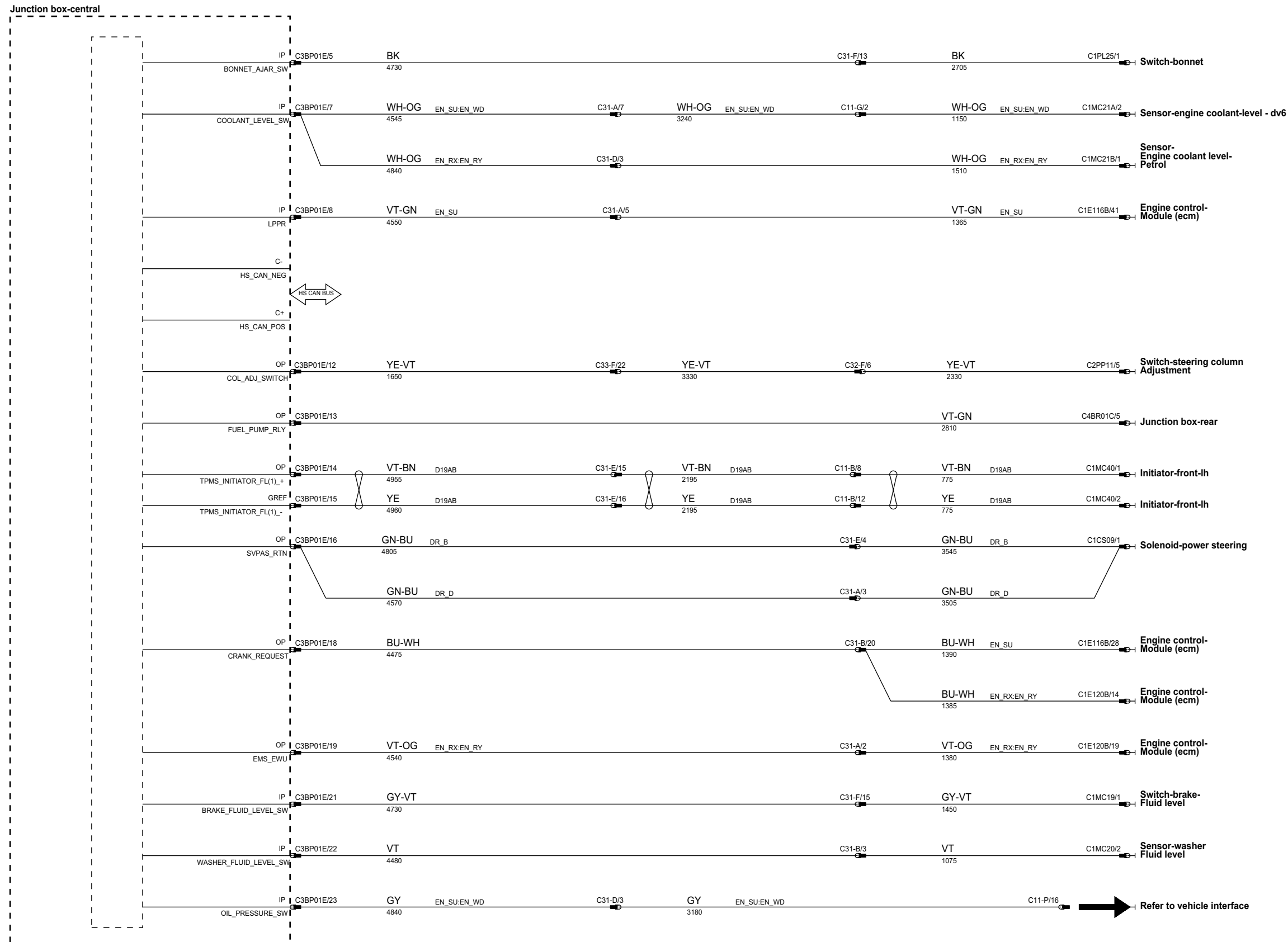

phcw93-70010-z-a3

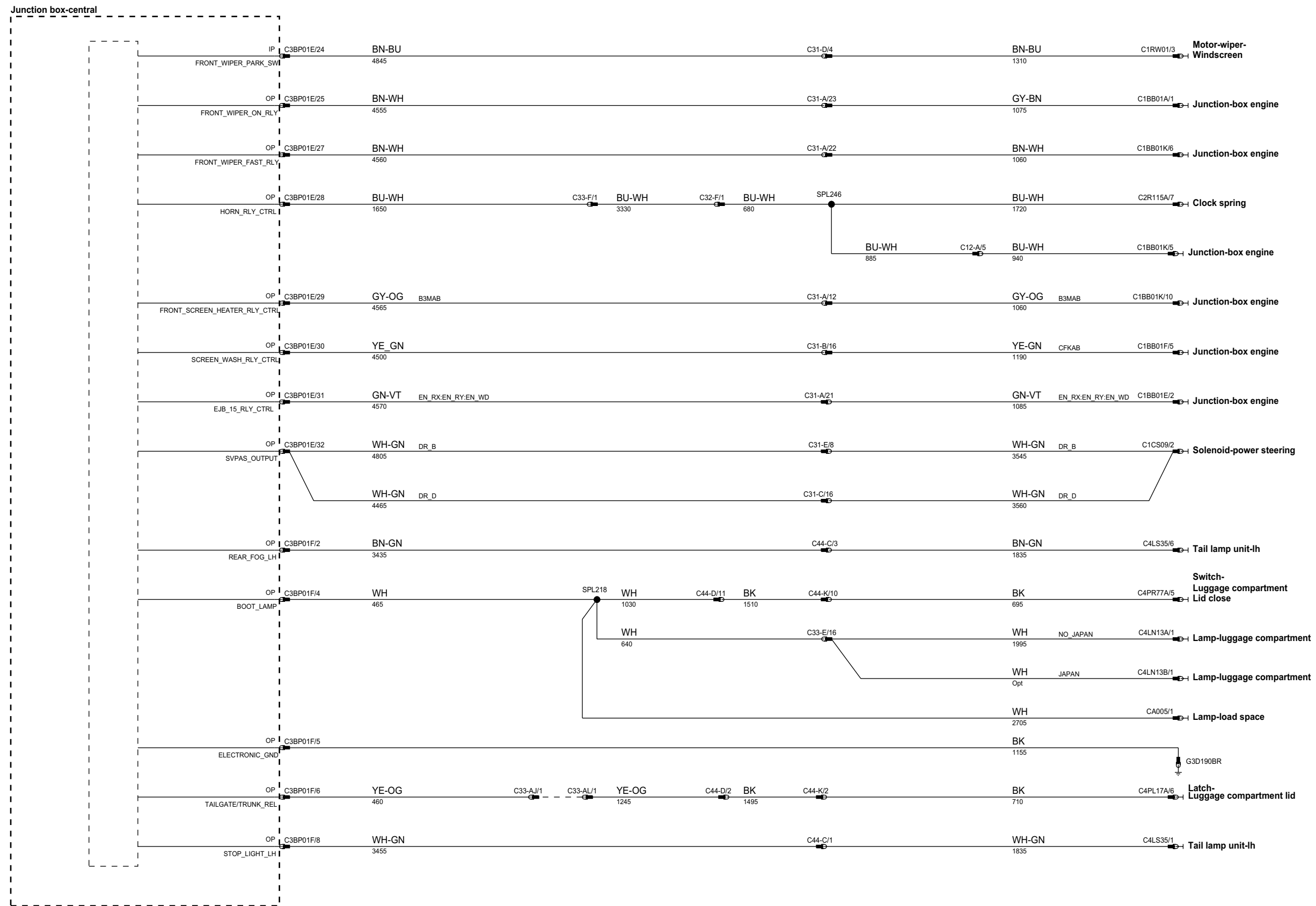

phcw93-70010-za-a3

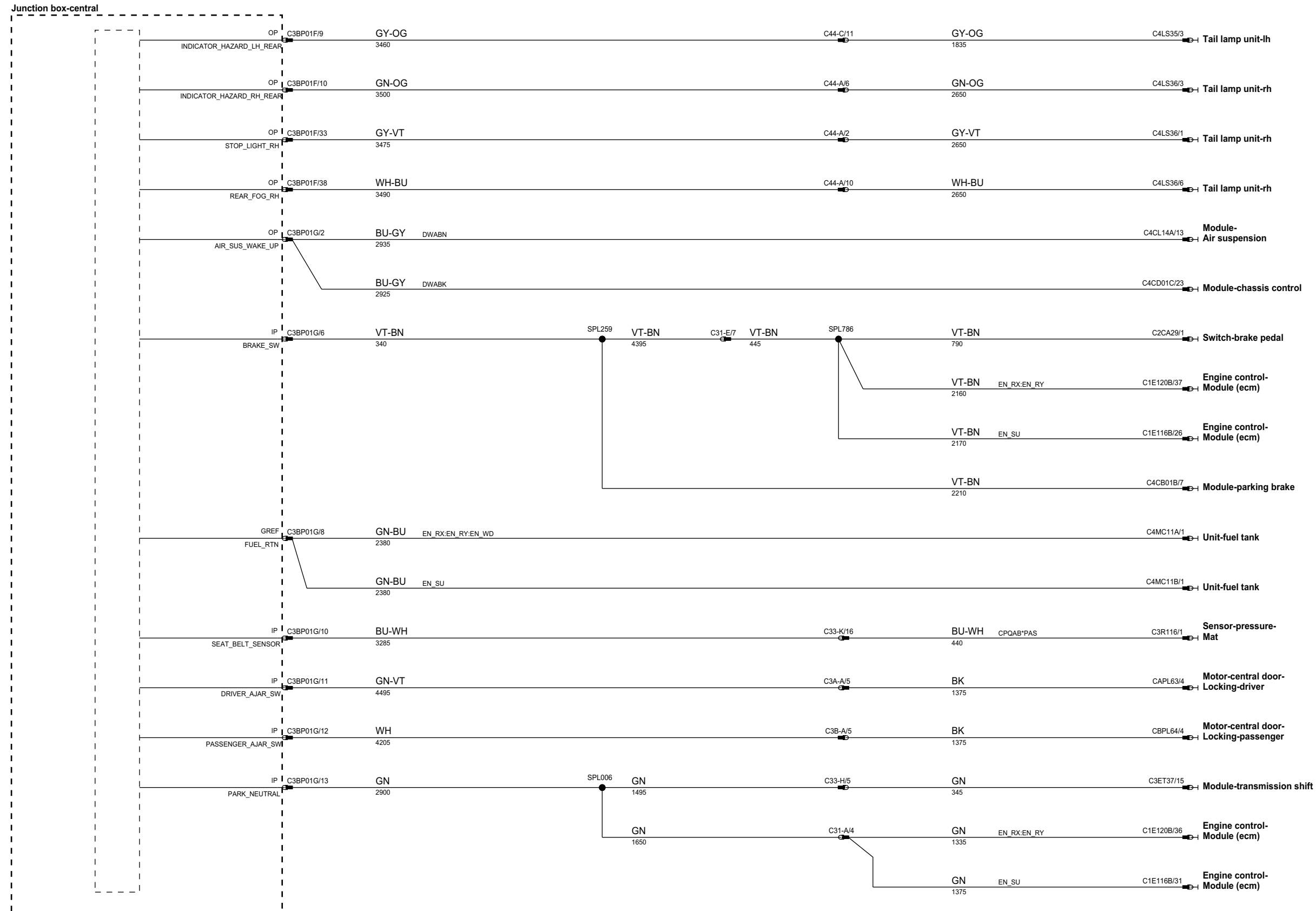

phcw93-70010-zb-a3

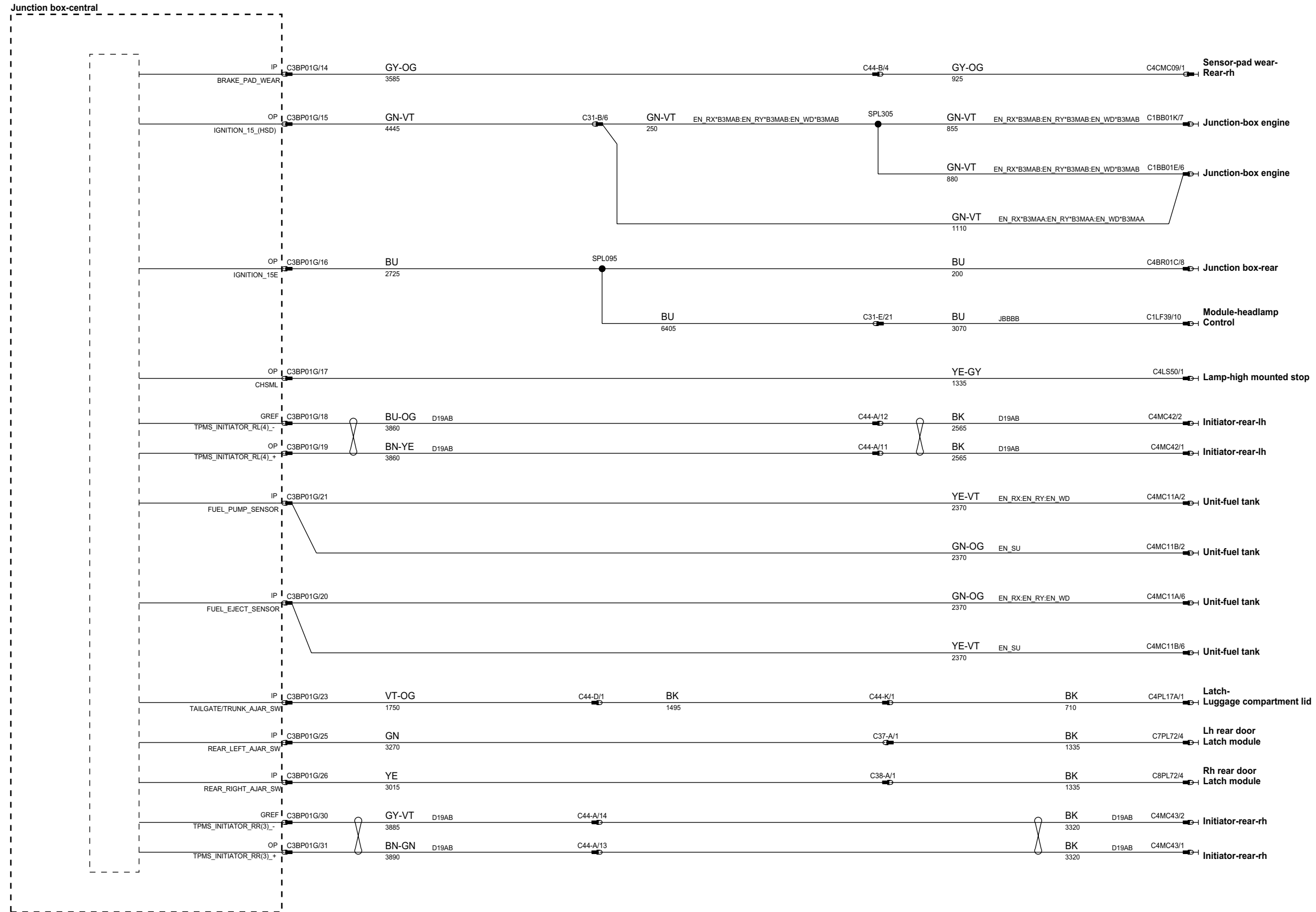

phcw93-70010-zc-a3

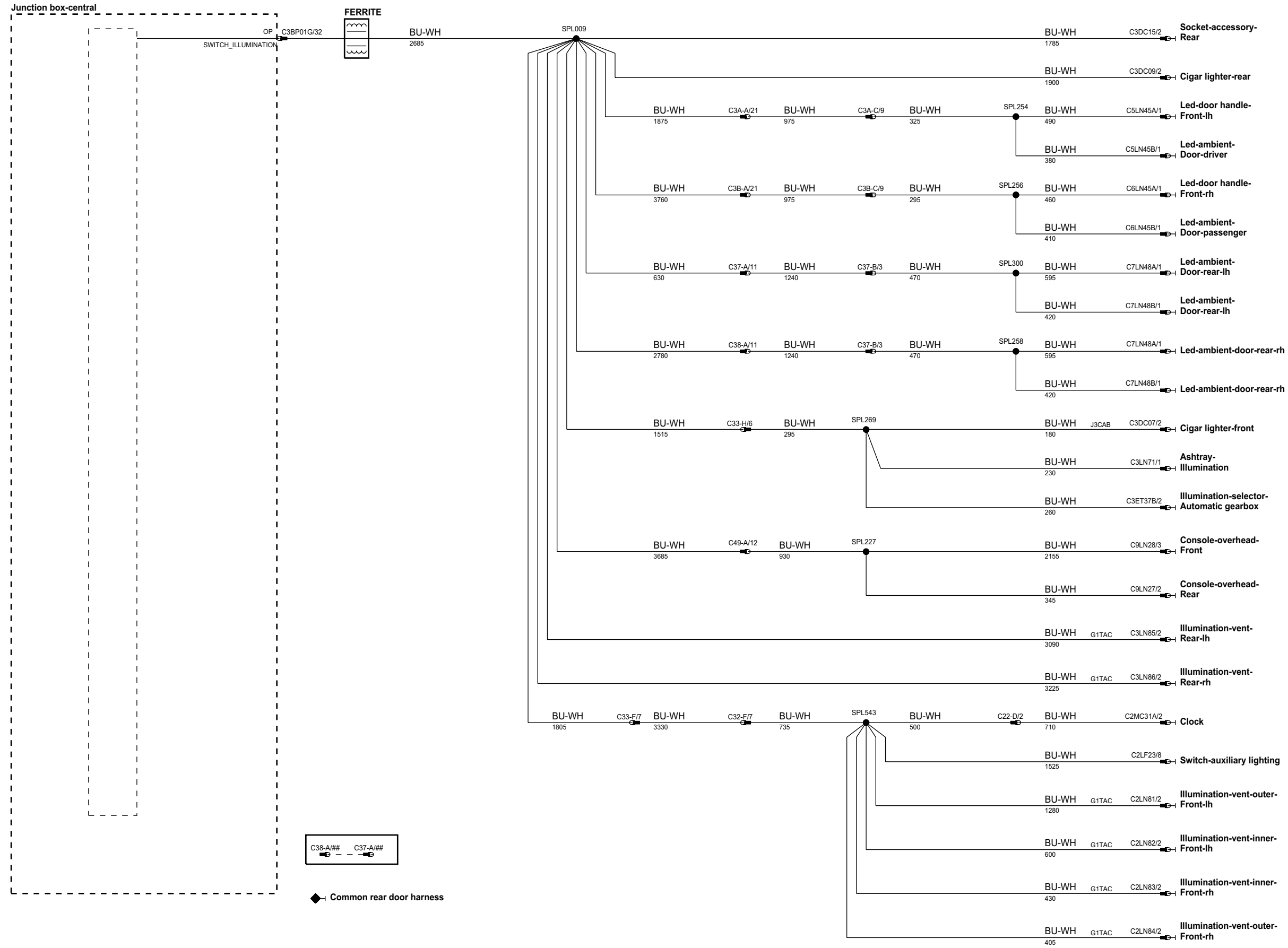

phcw93-70010-zd-a3

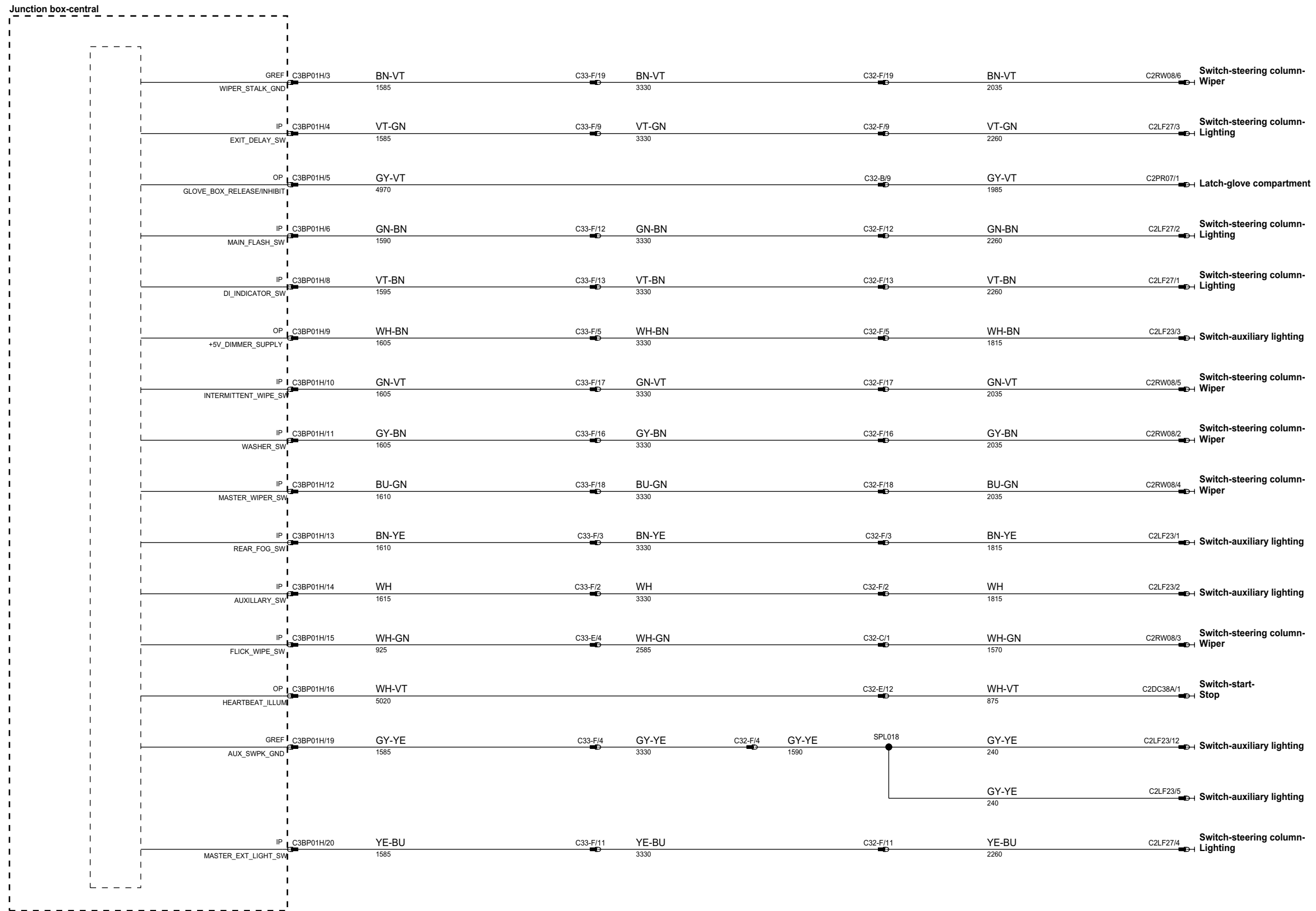

phcw93-70010-z6-a3

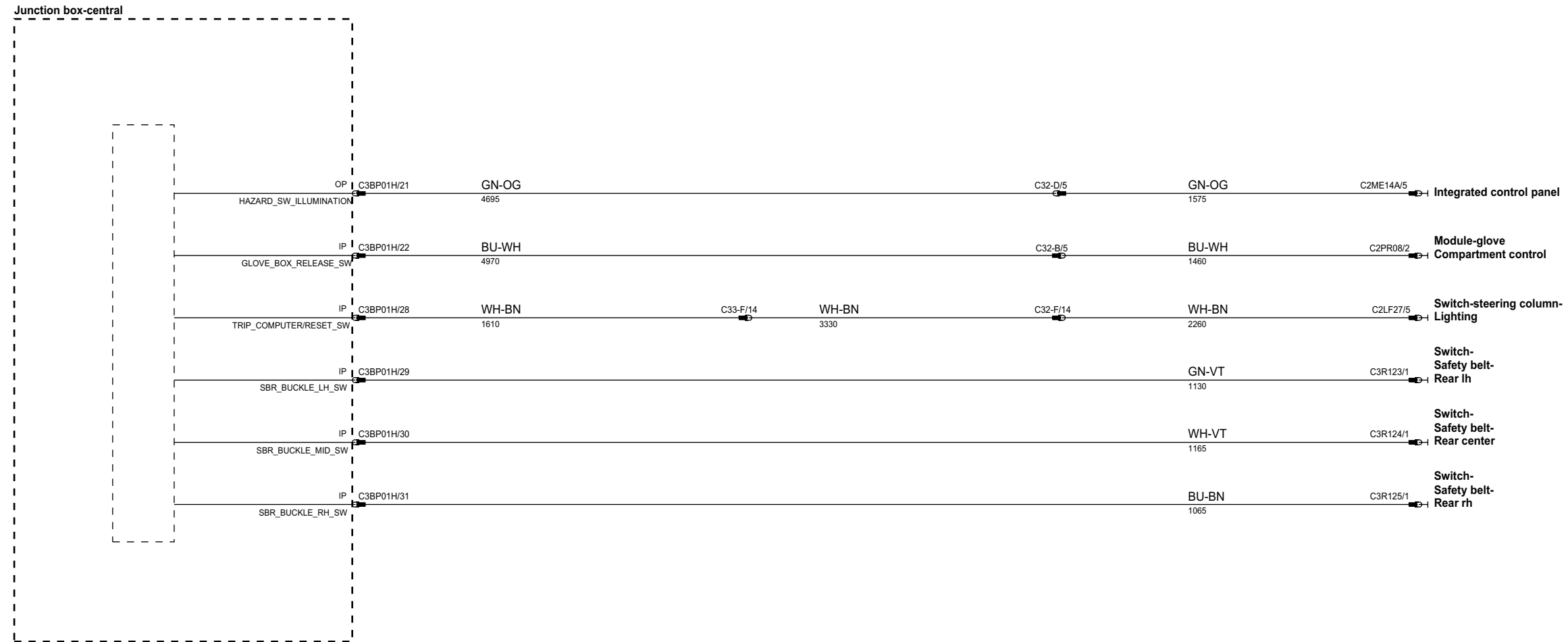

phcw93-70010-g-a3

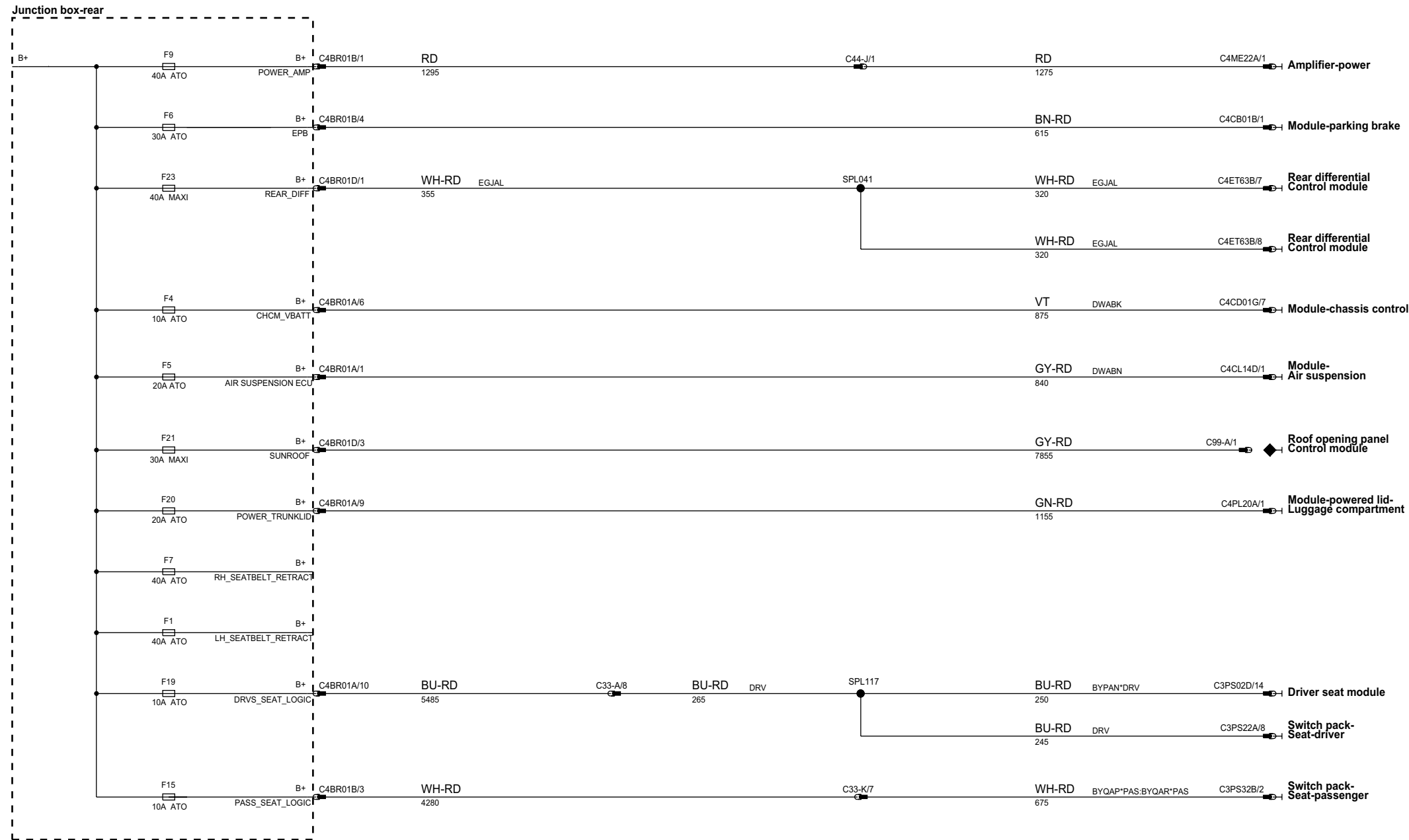

phcw93-70010-h-a3

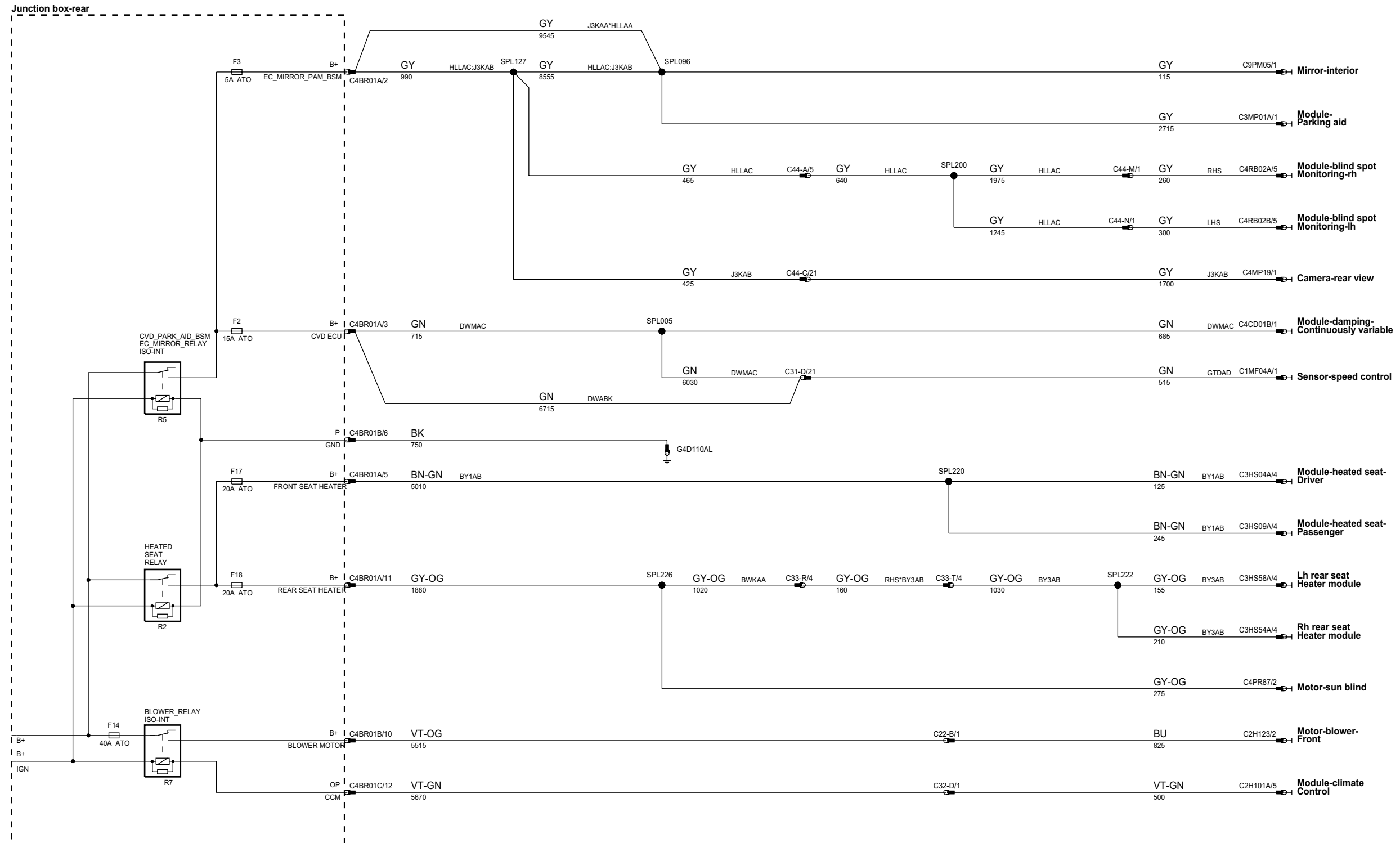

phcw93-70010-j-a3

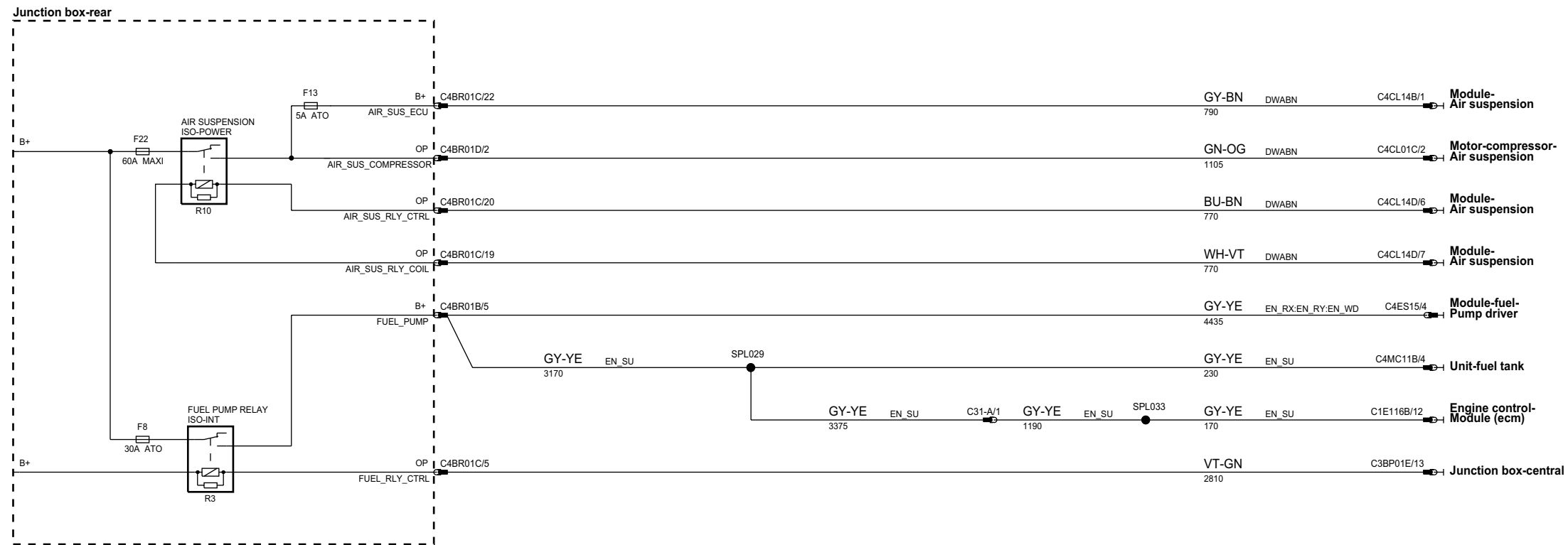

phcw93-70012-a-a3

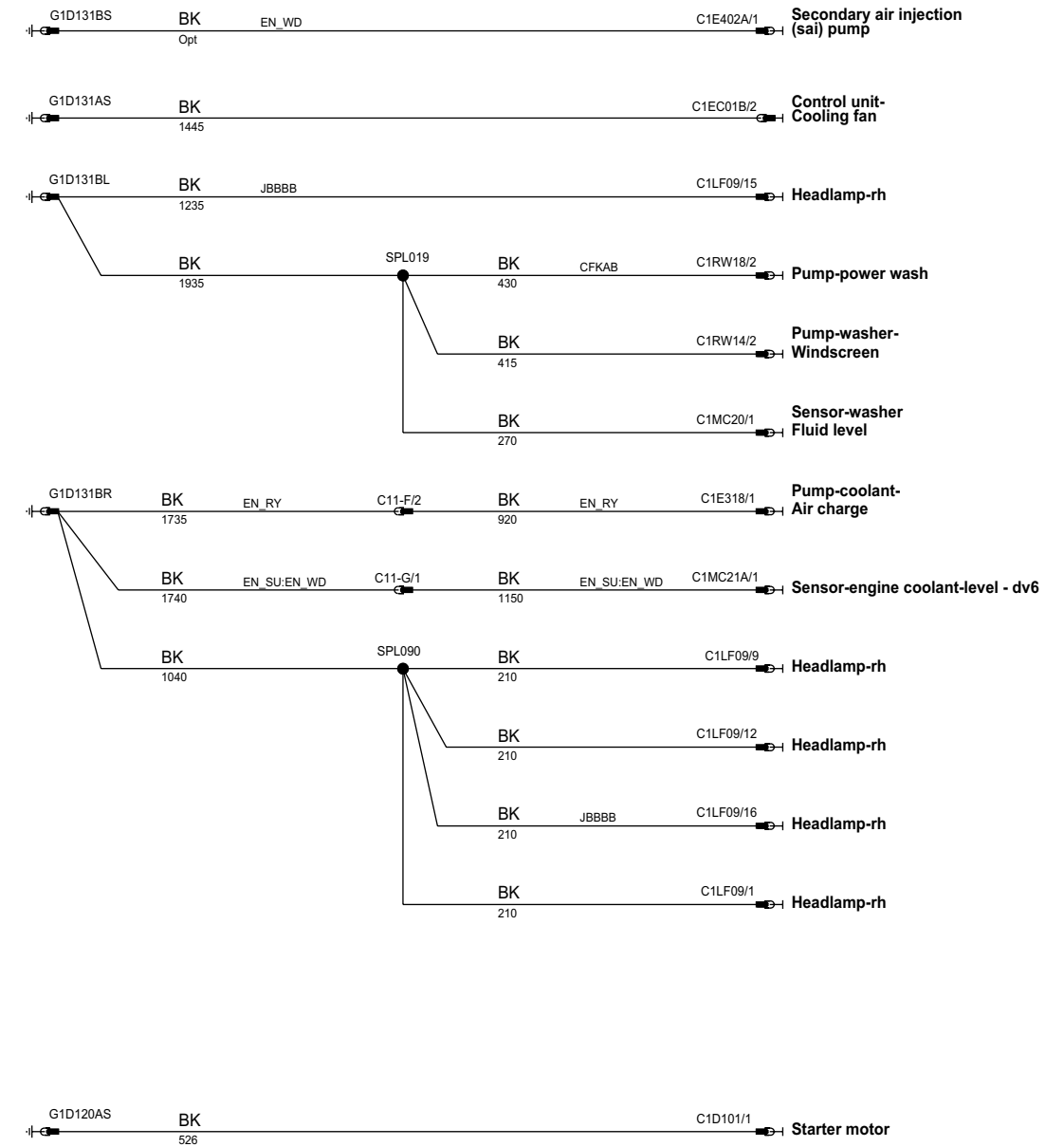
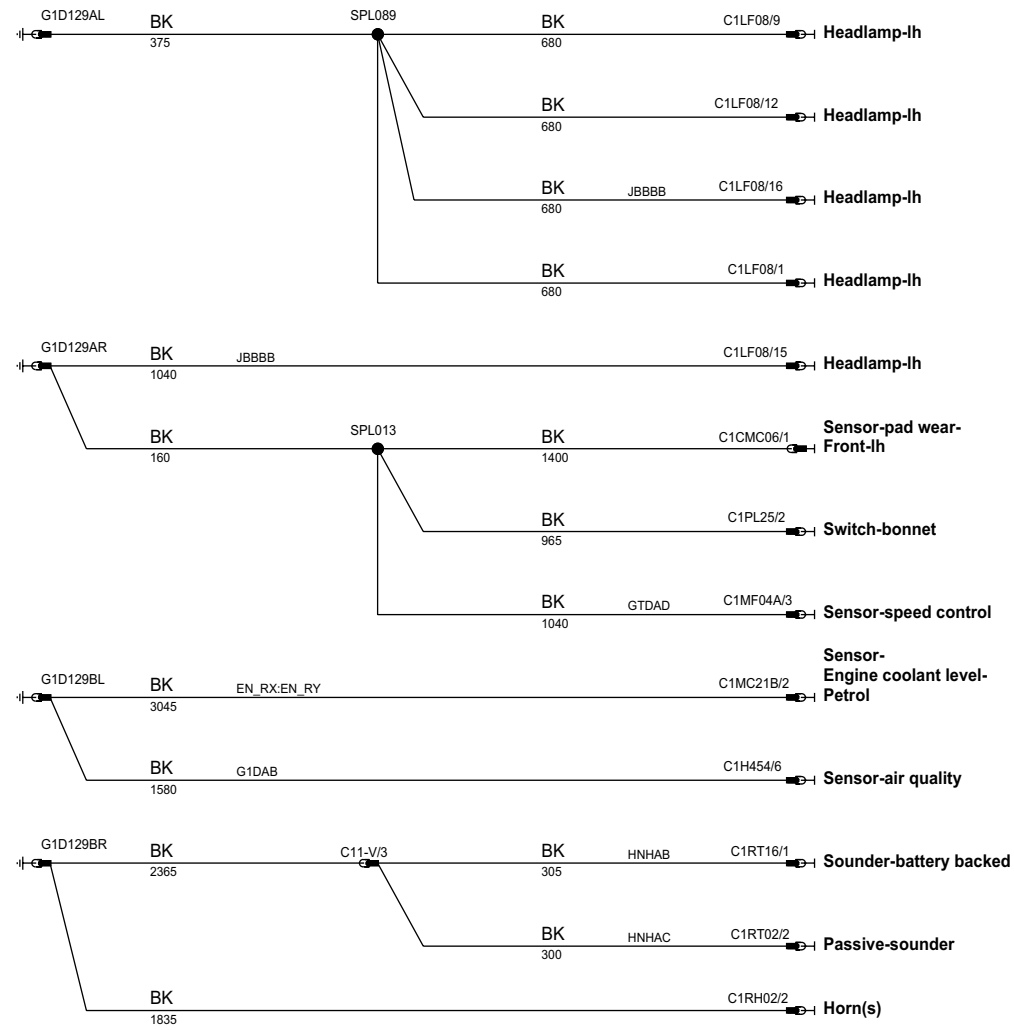

phcw93-70012-b-a3

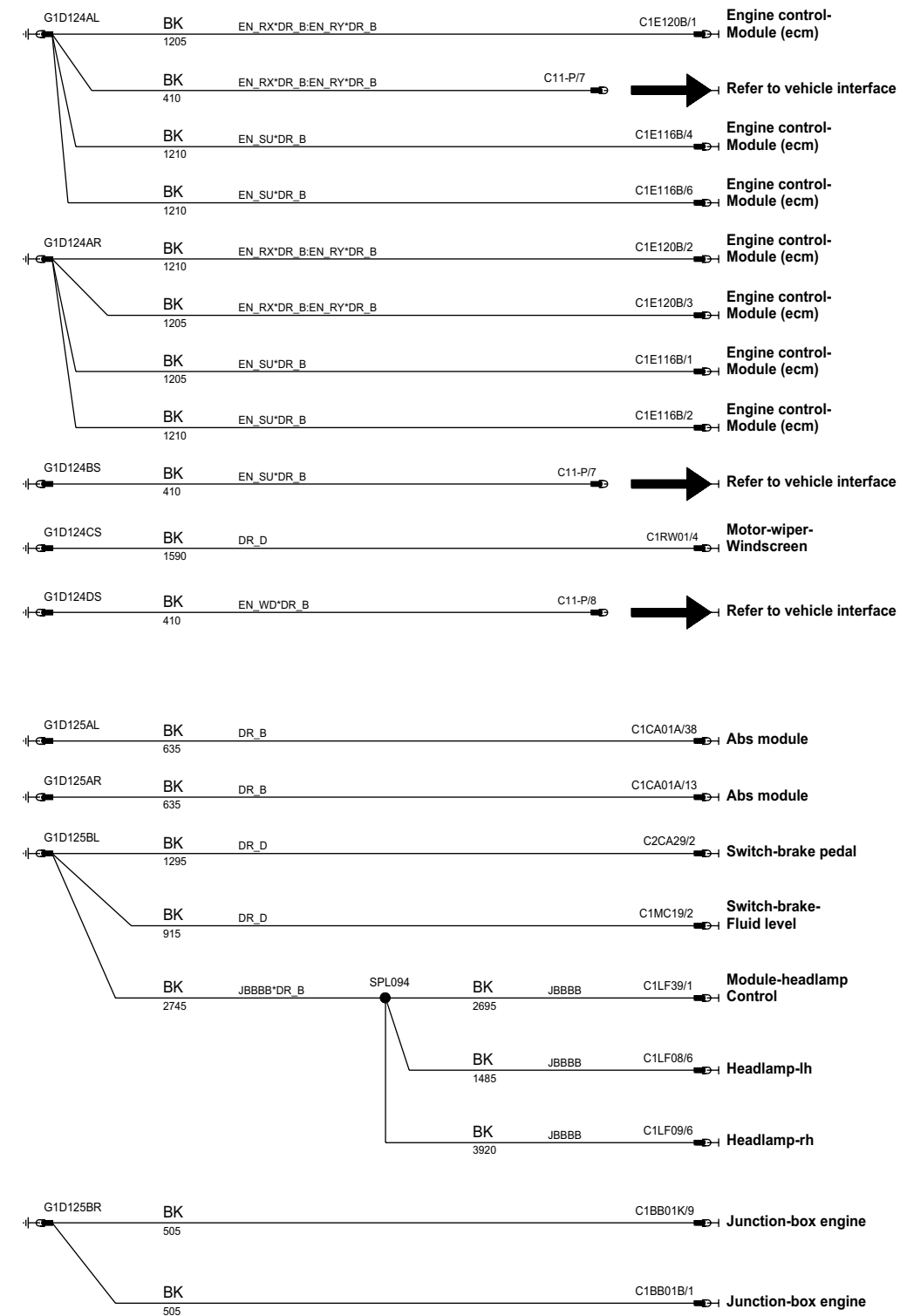
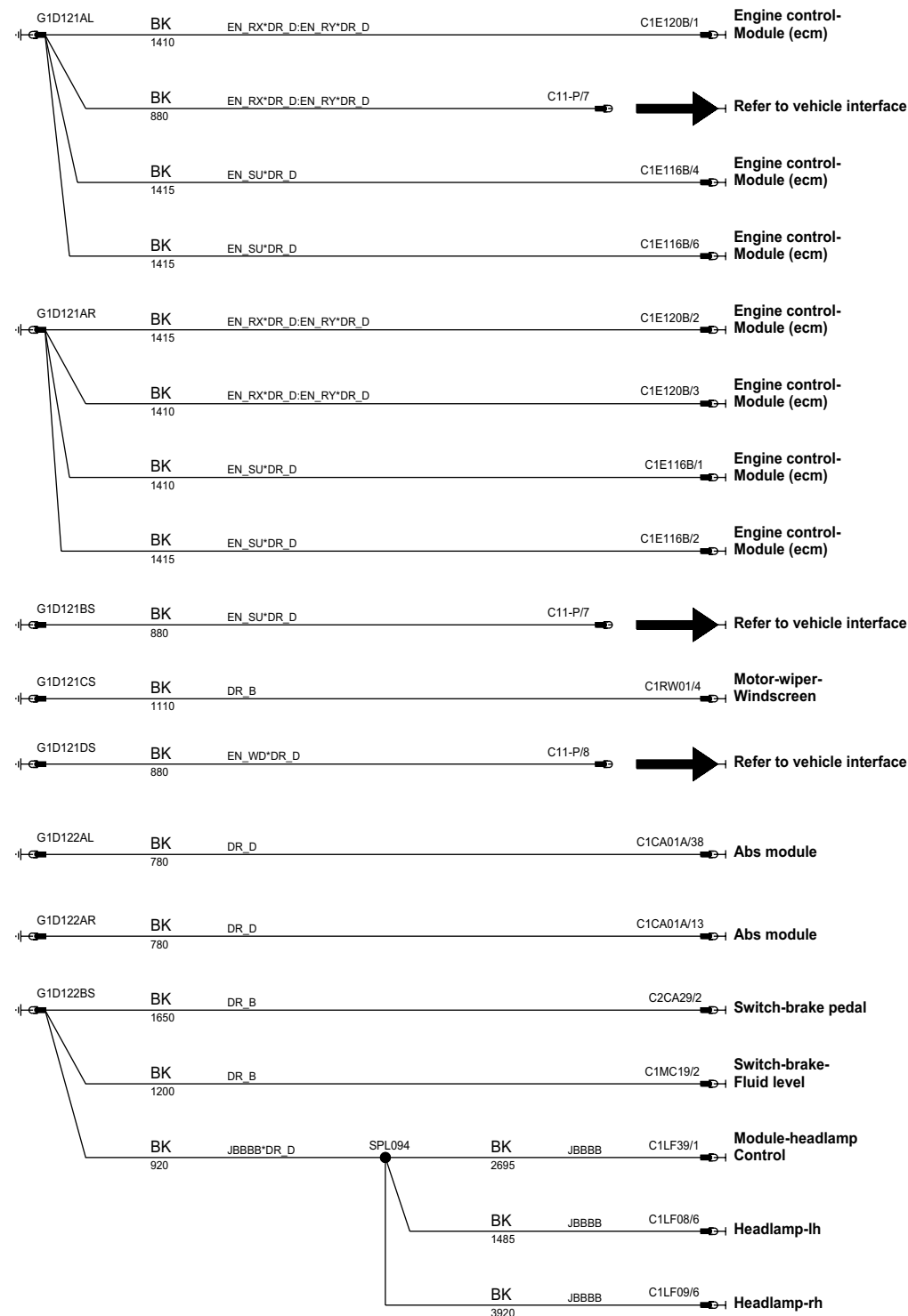

phcw93-70012-c-a3

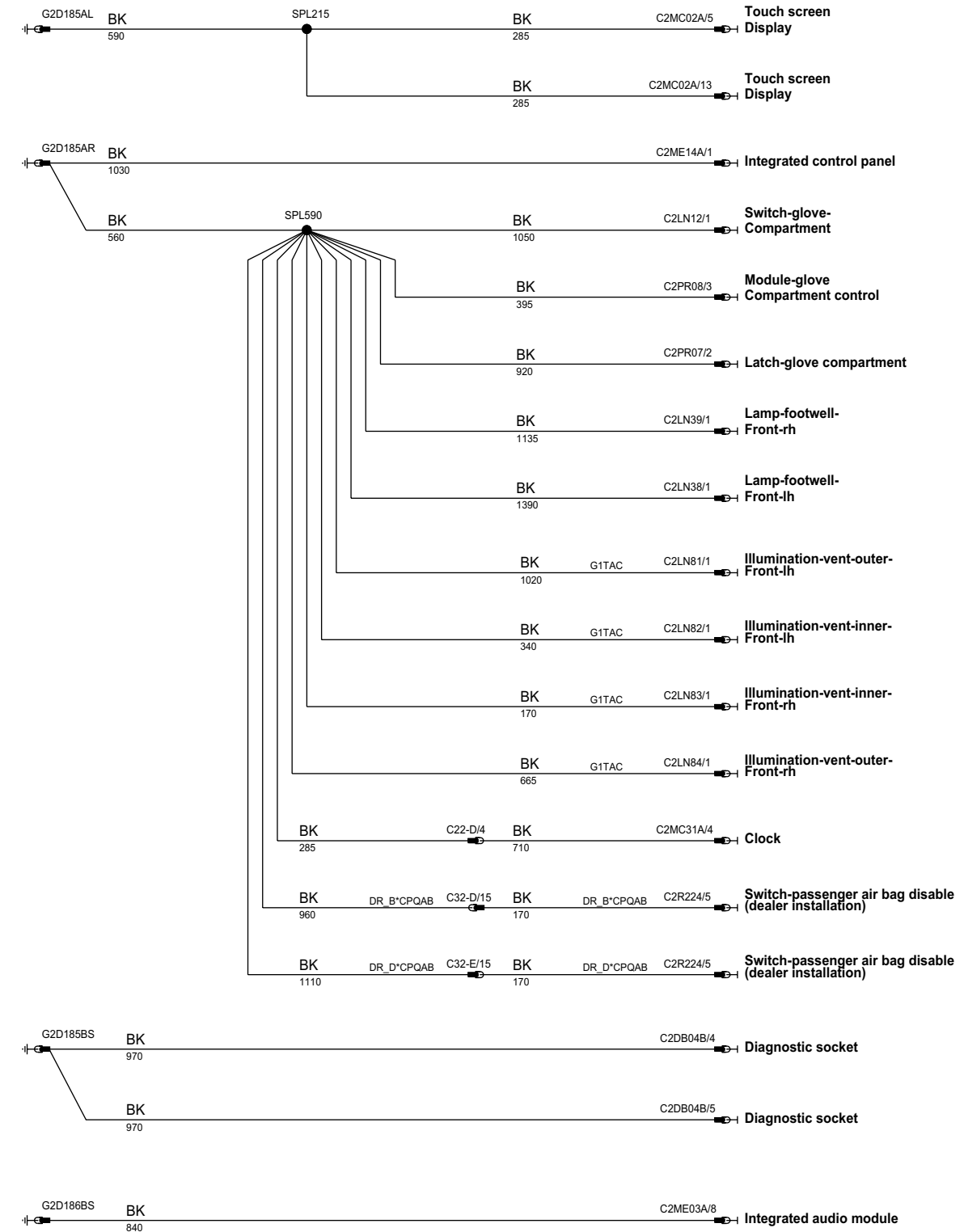
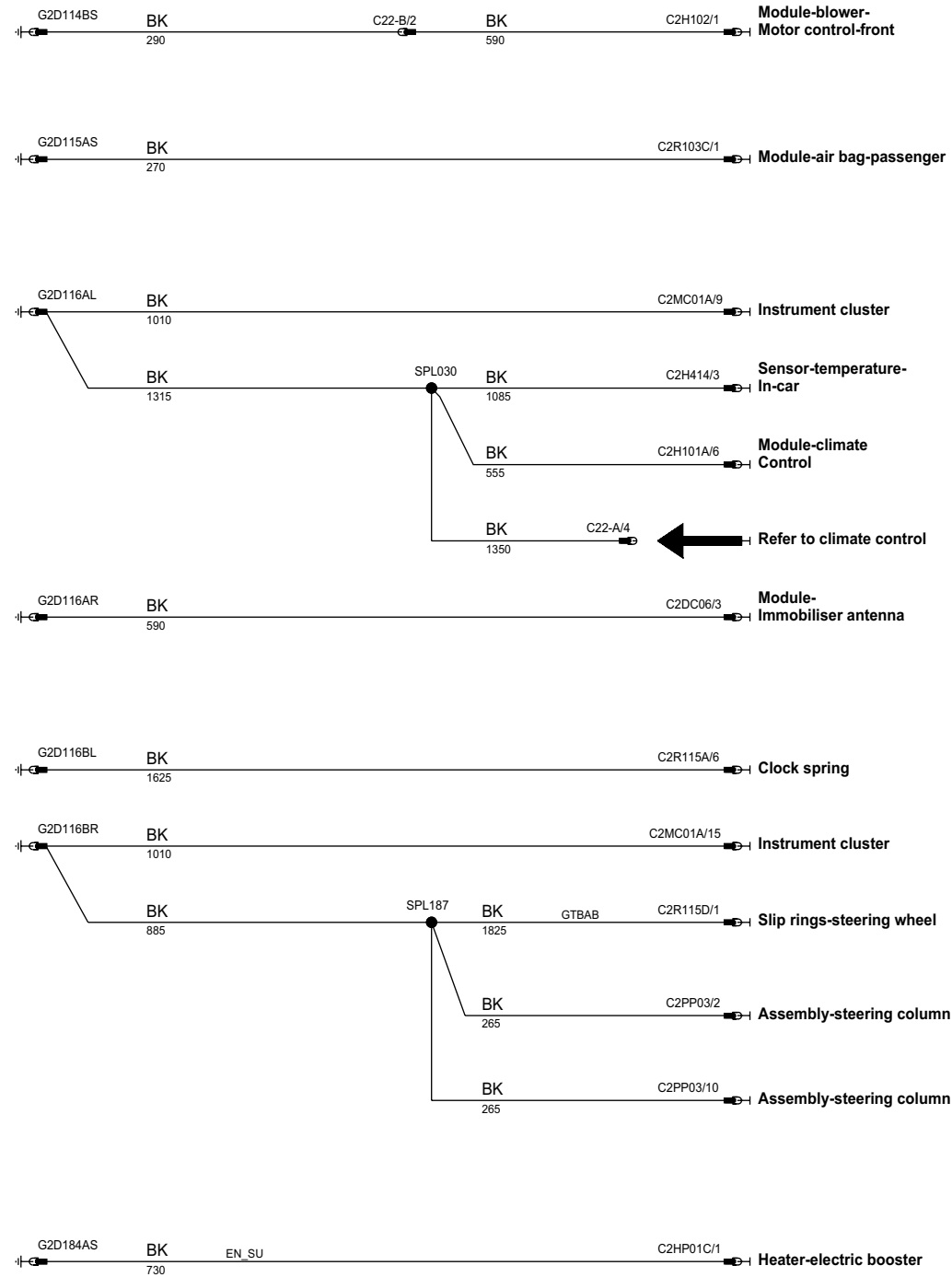

phcw93-70012-d-a3

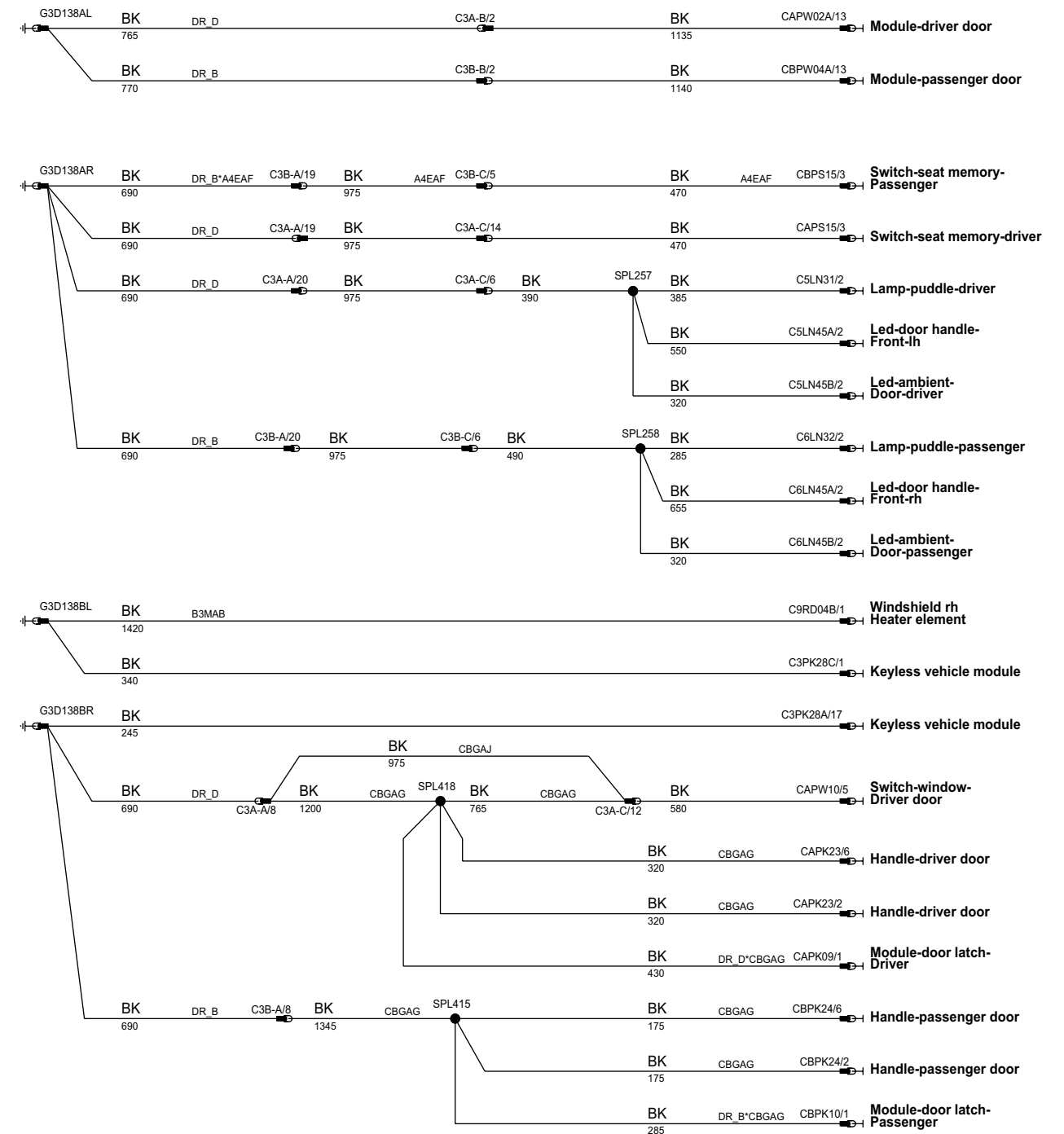
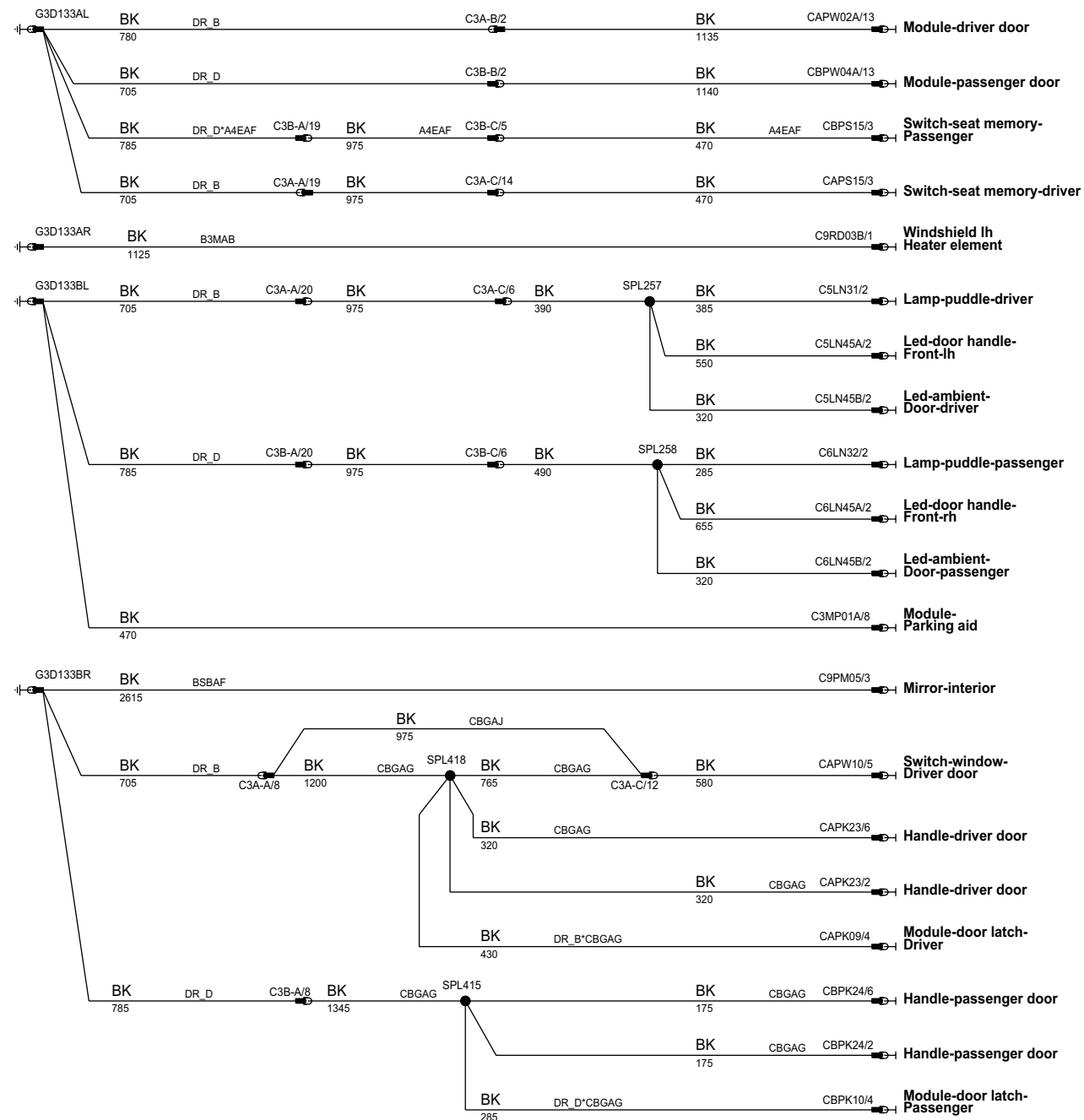

phcw93-70012-e-a3

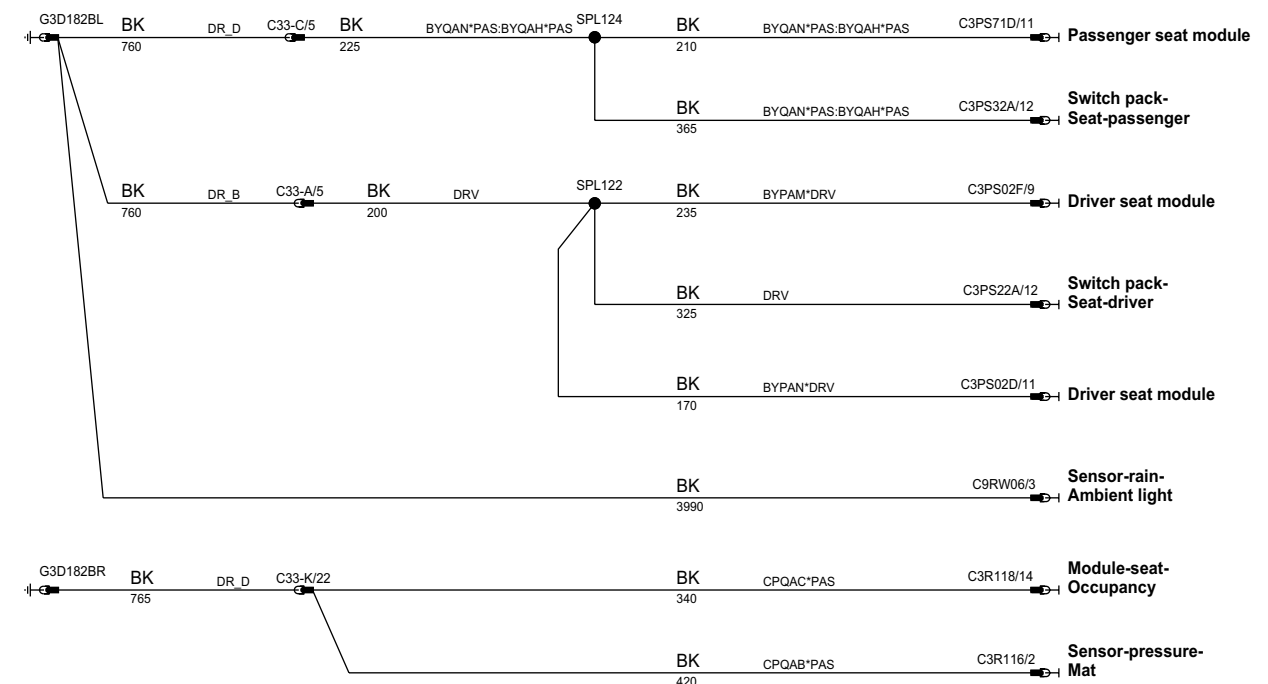
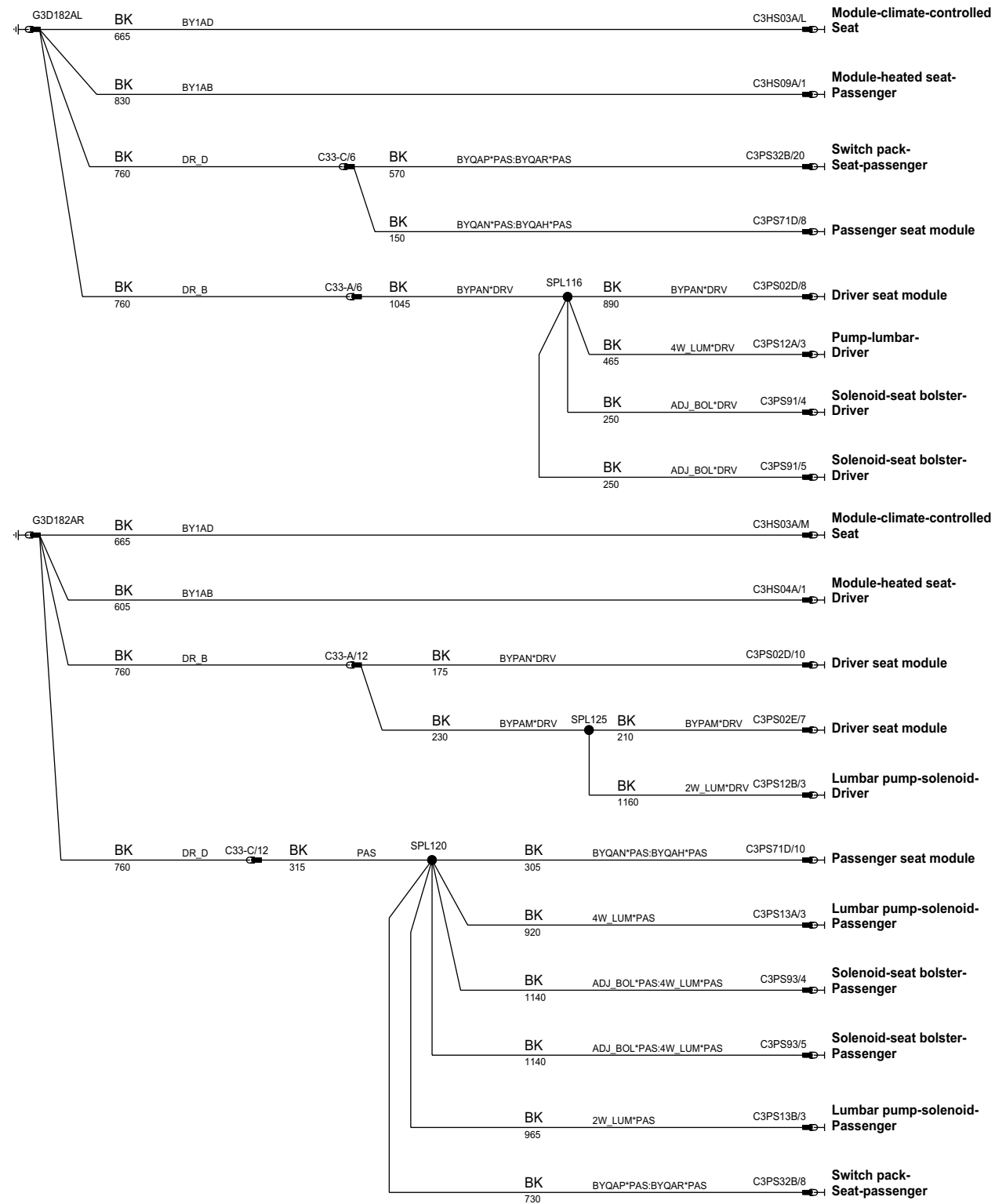

phcw93-700124-a3

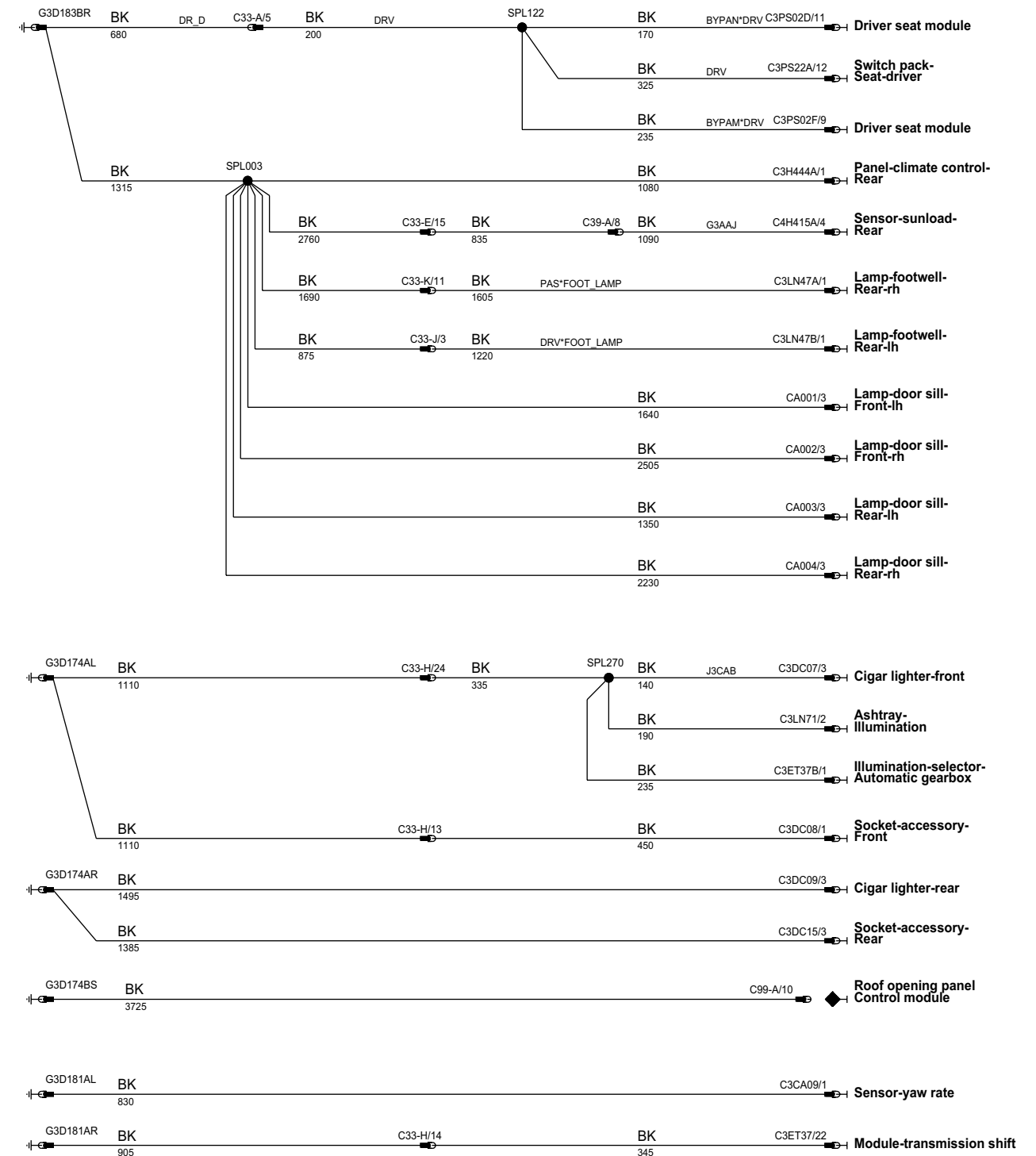
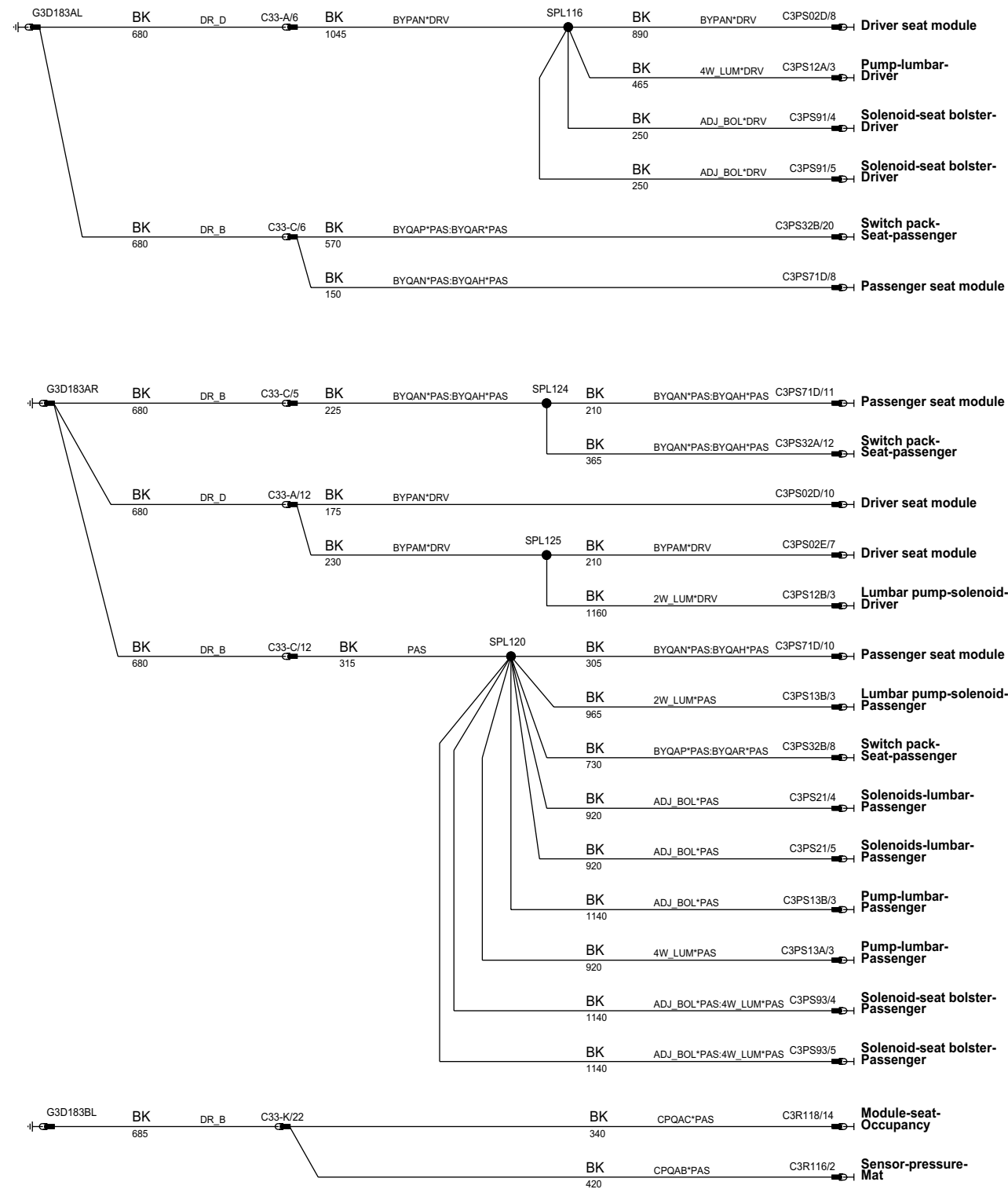

phcw93-70012-g-a3

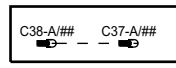
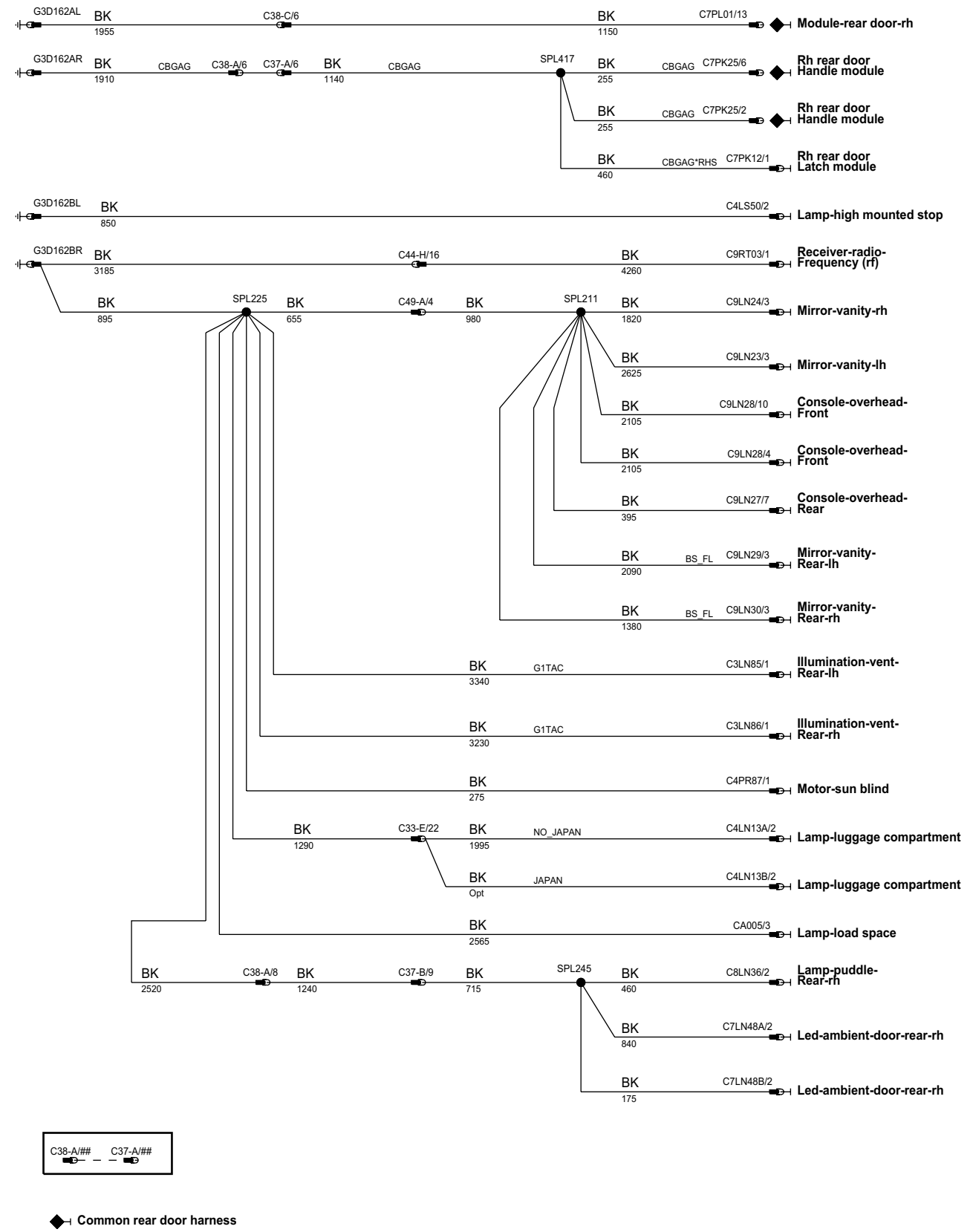
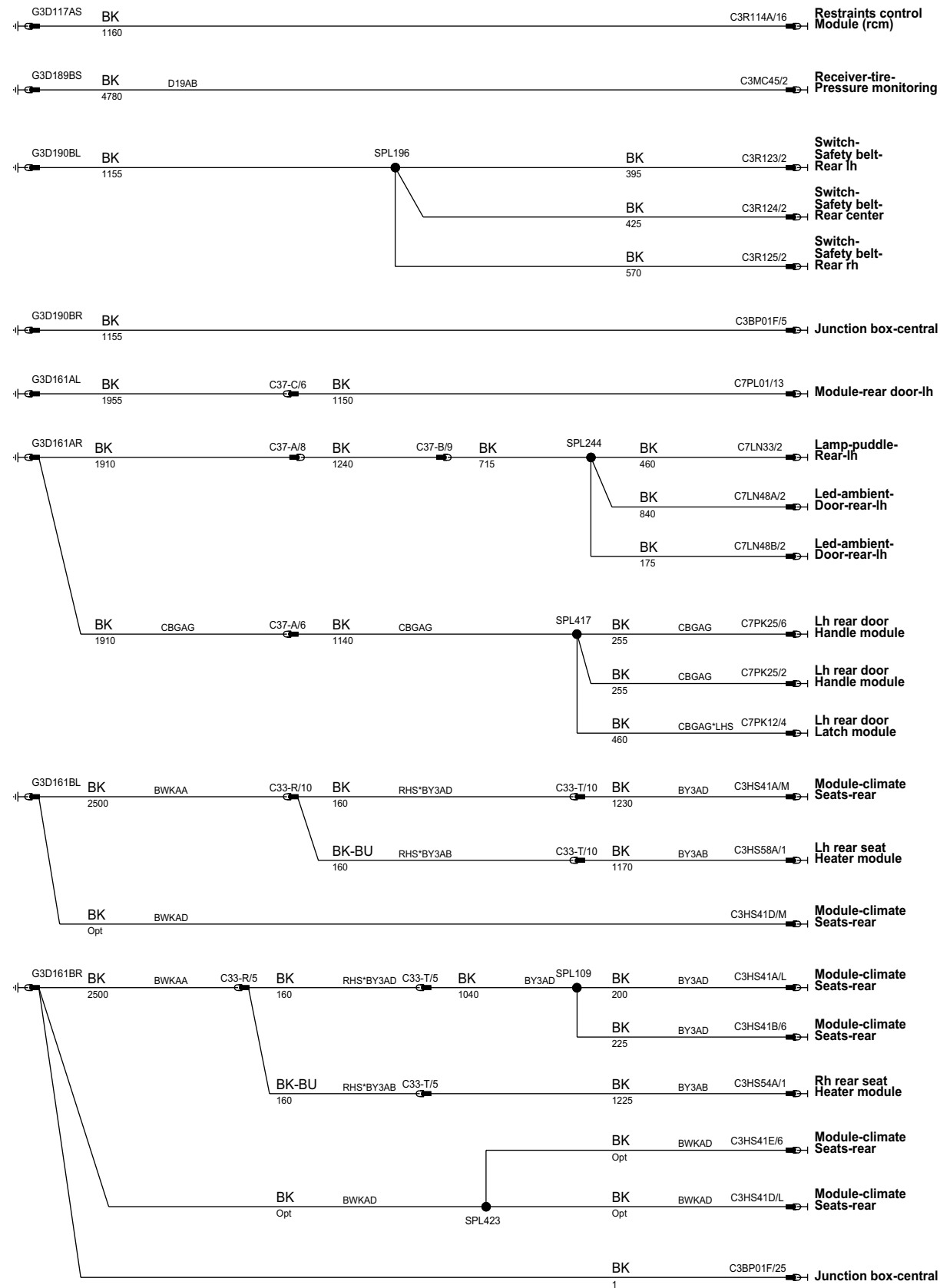

◆ Common rear door harness

phcw93-70012-h-a3

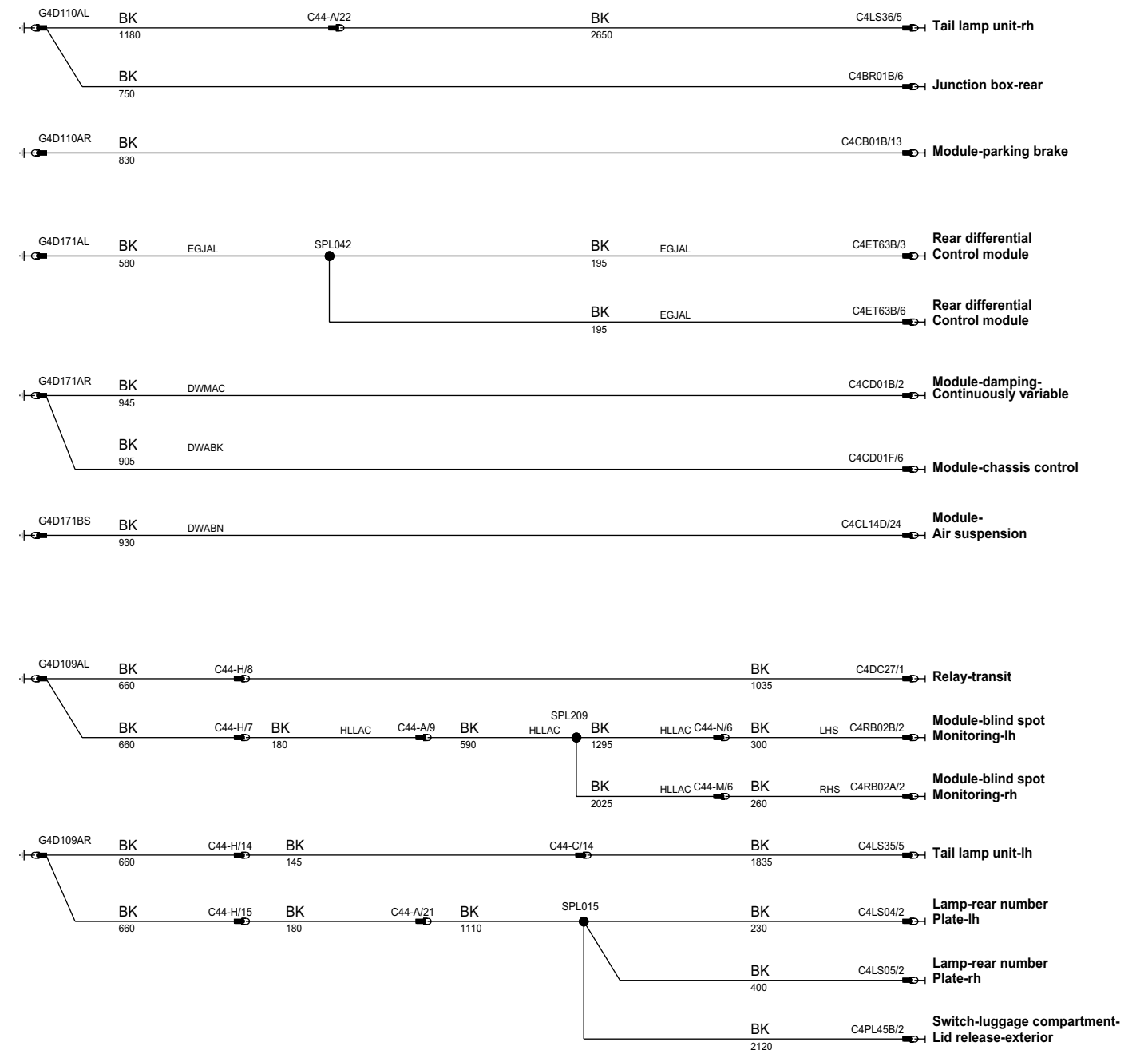
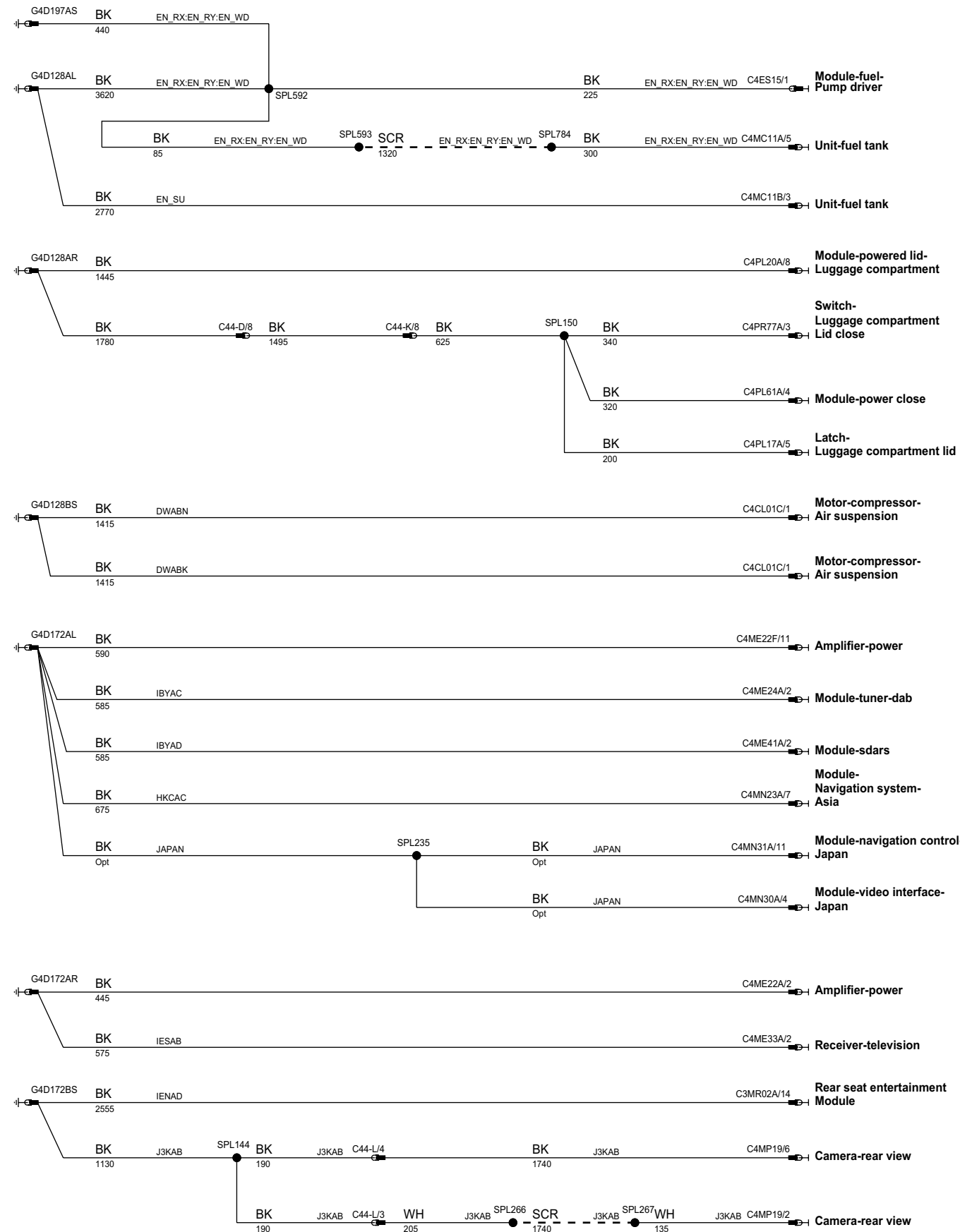

phcw93-70022-a-a3

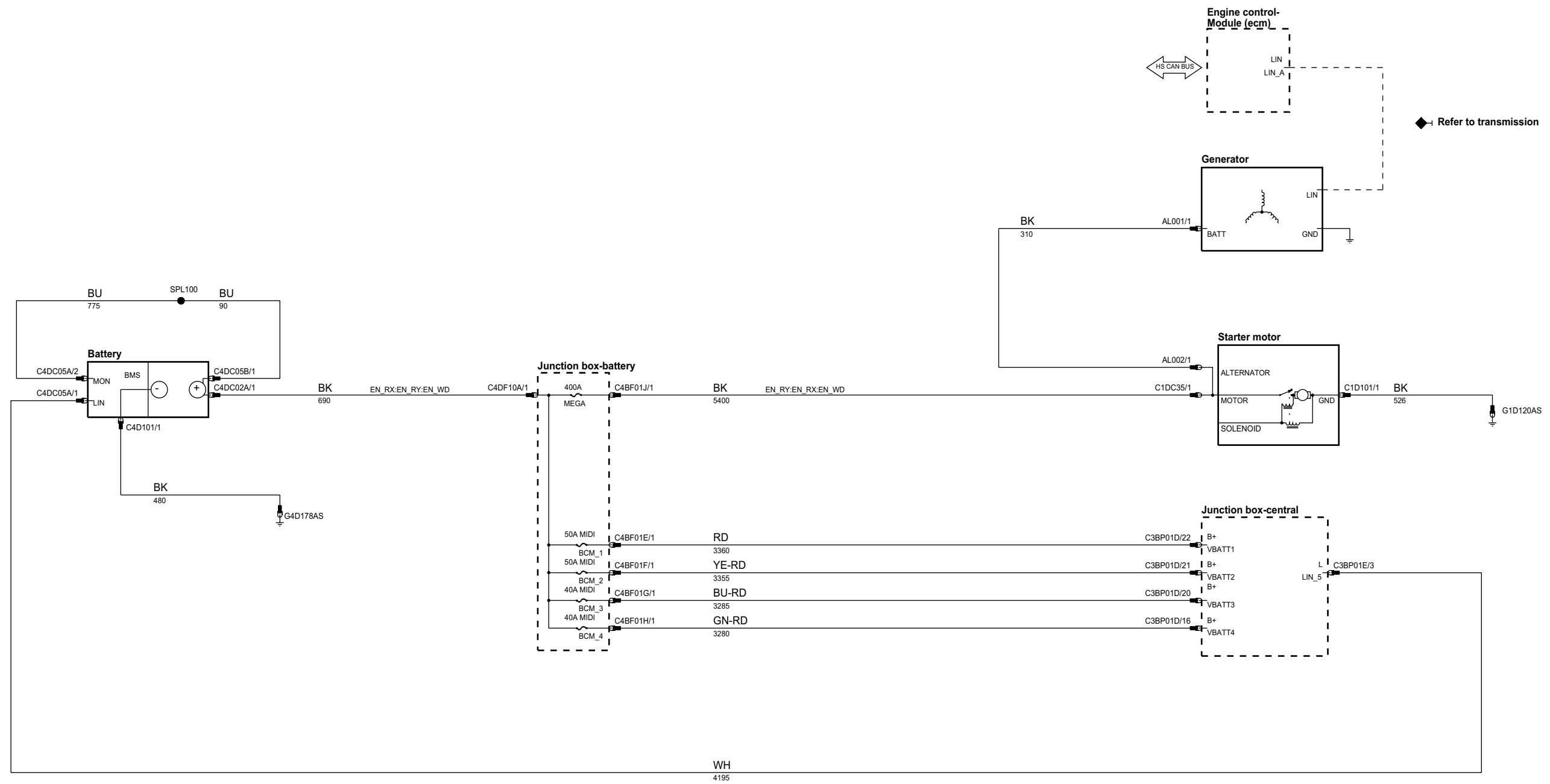

phcw93-70022-d-a3

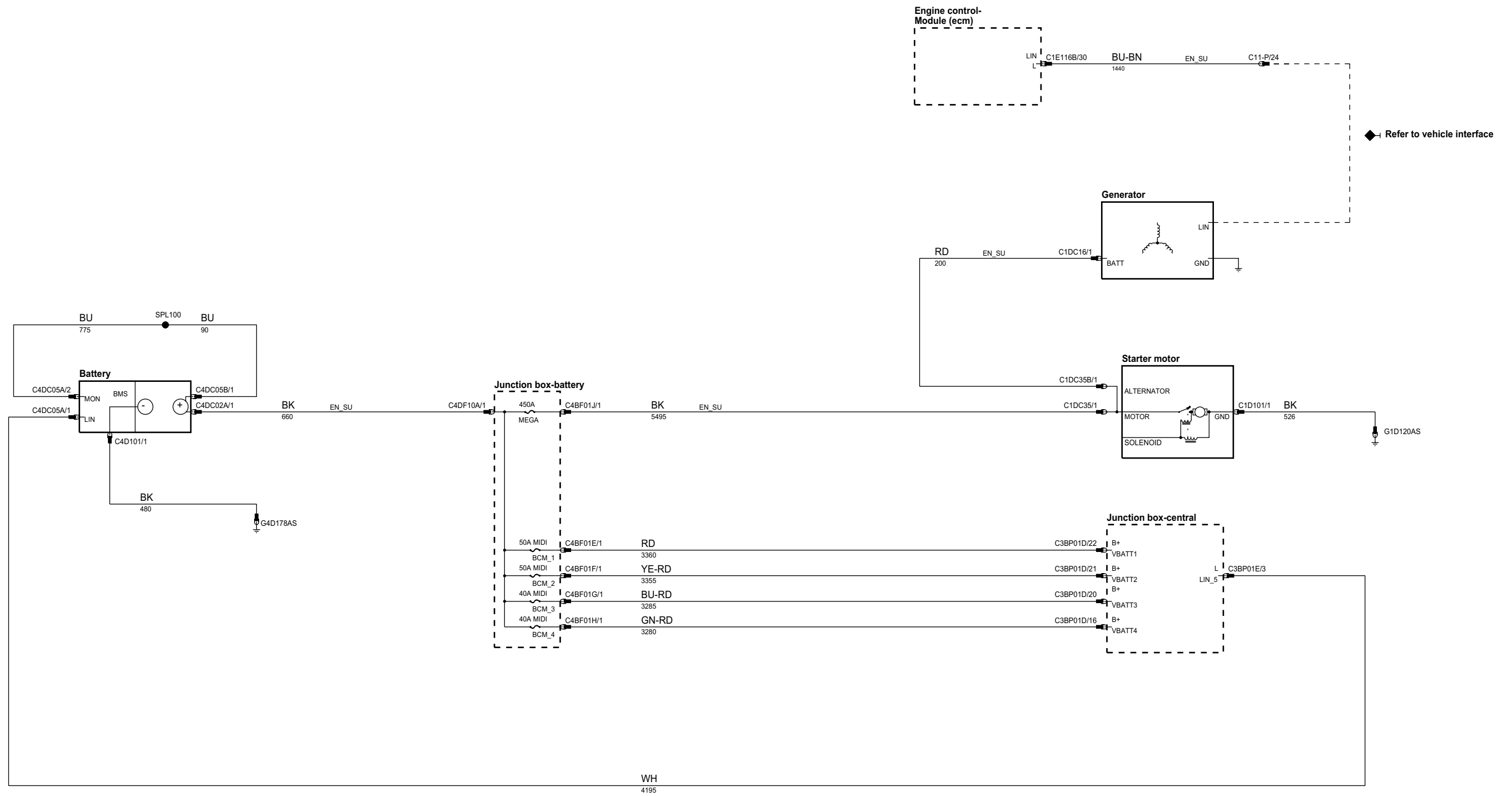

phow93-70441-a-a3

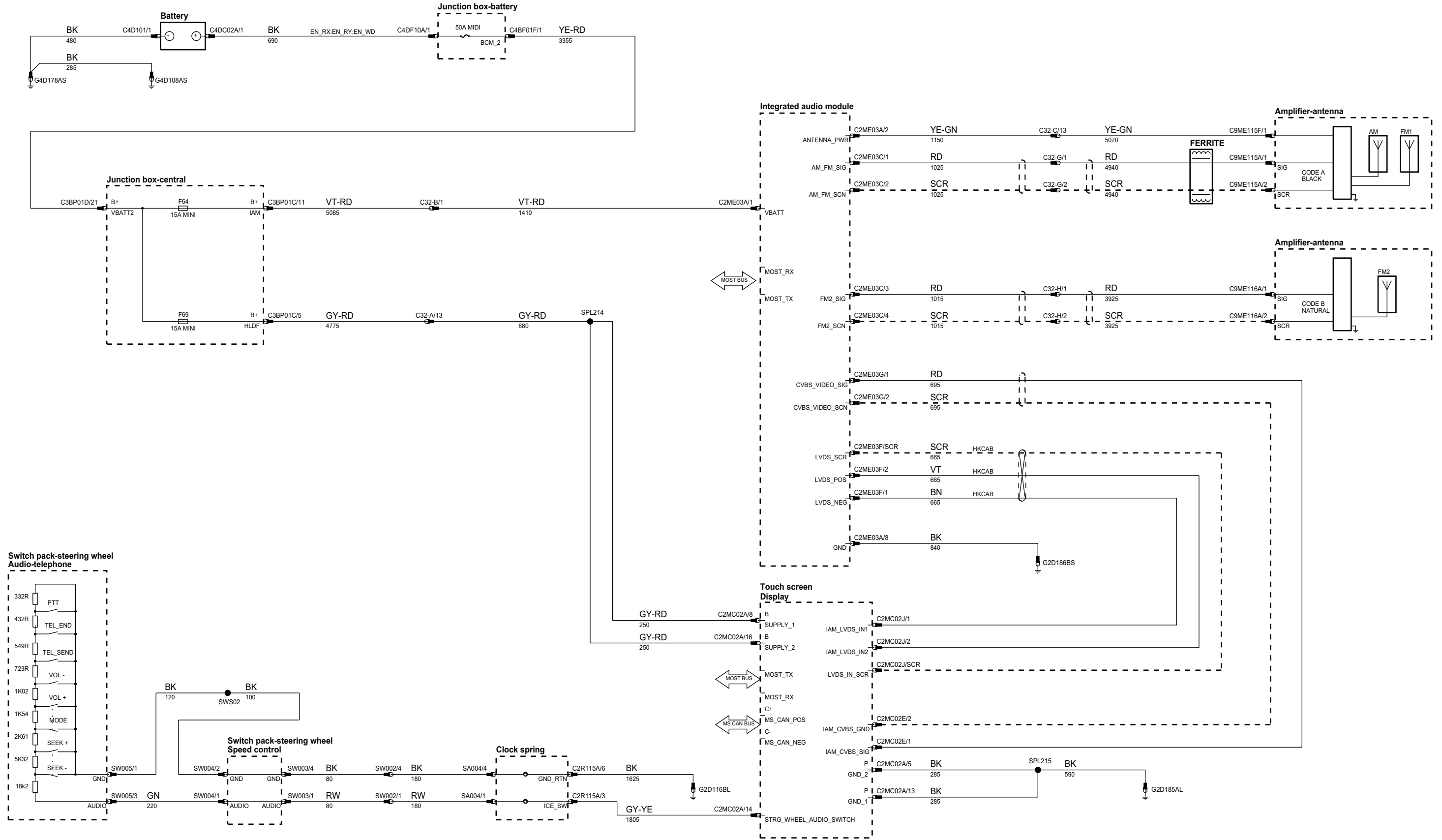

phcw93-70441-b-a3

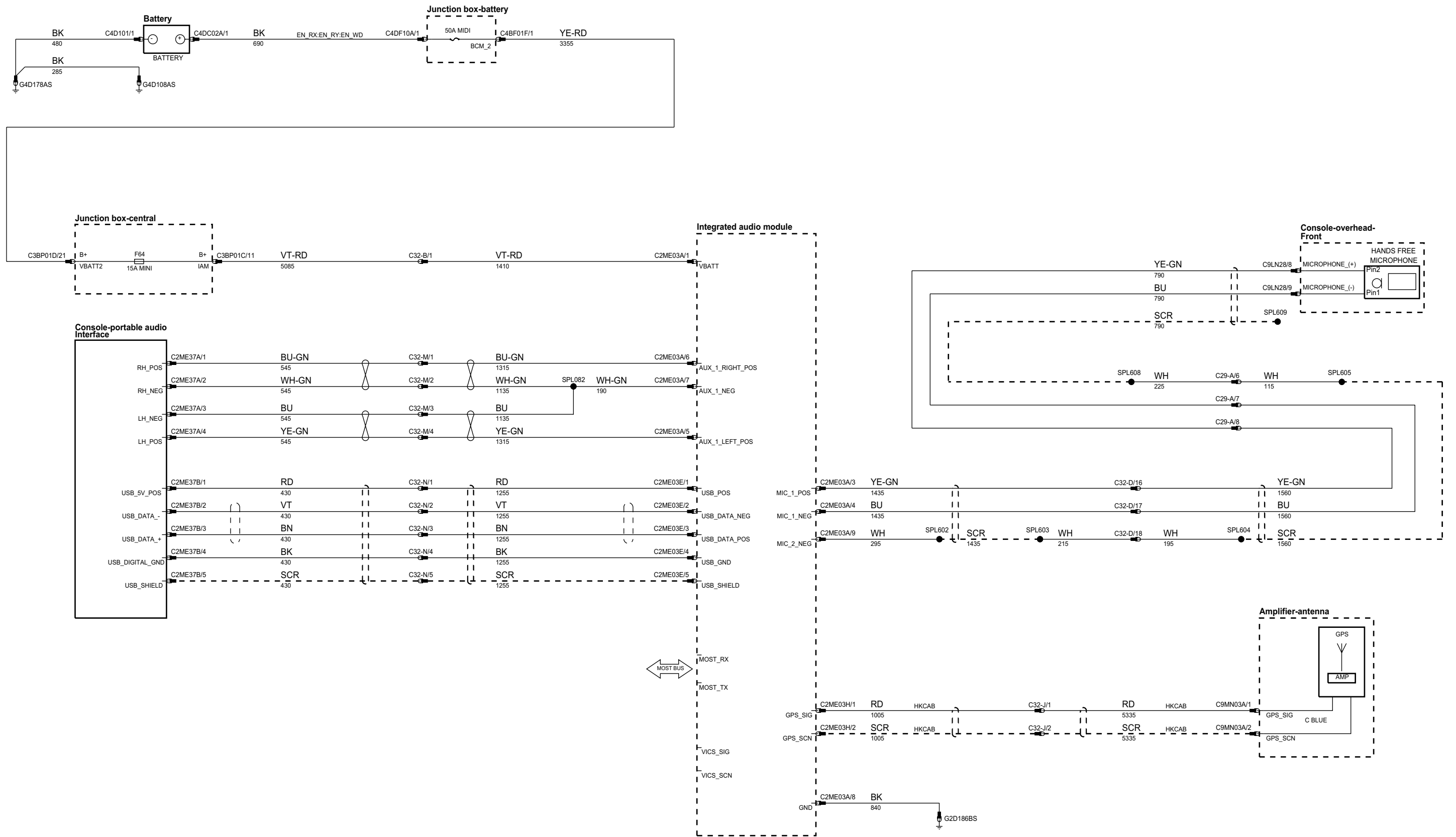

phcw93-70441-c-a3

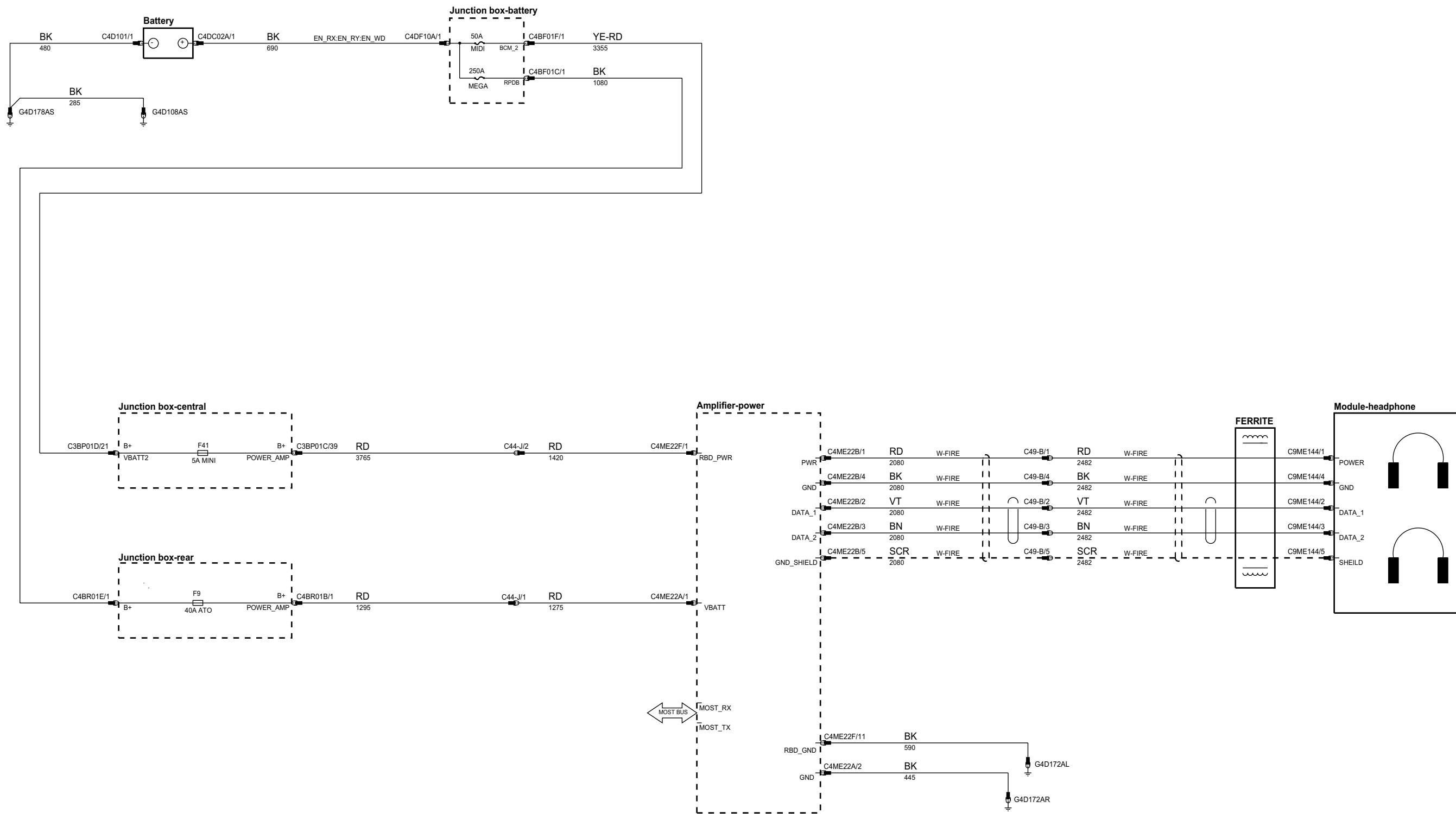

x

phcw93-70441-d-a3

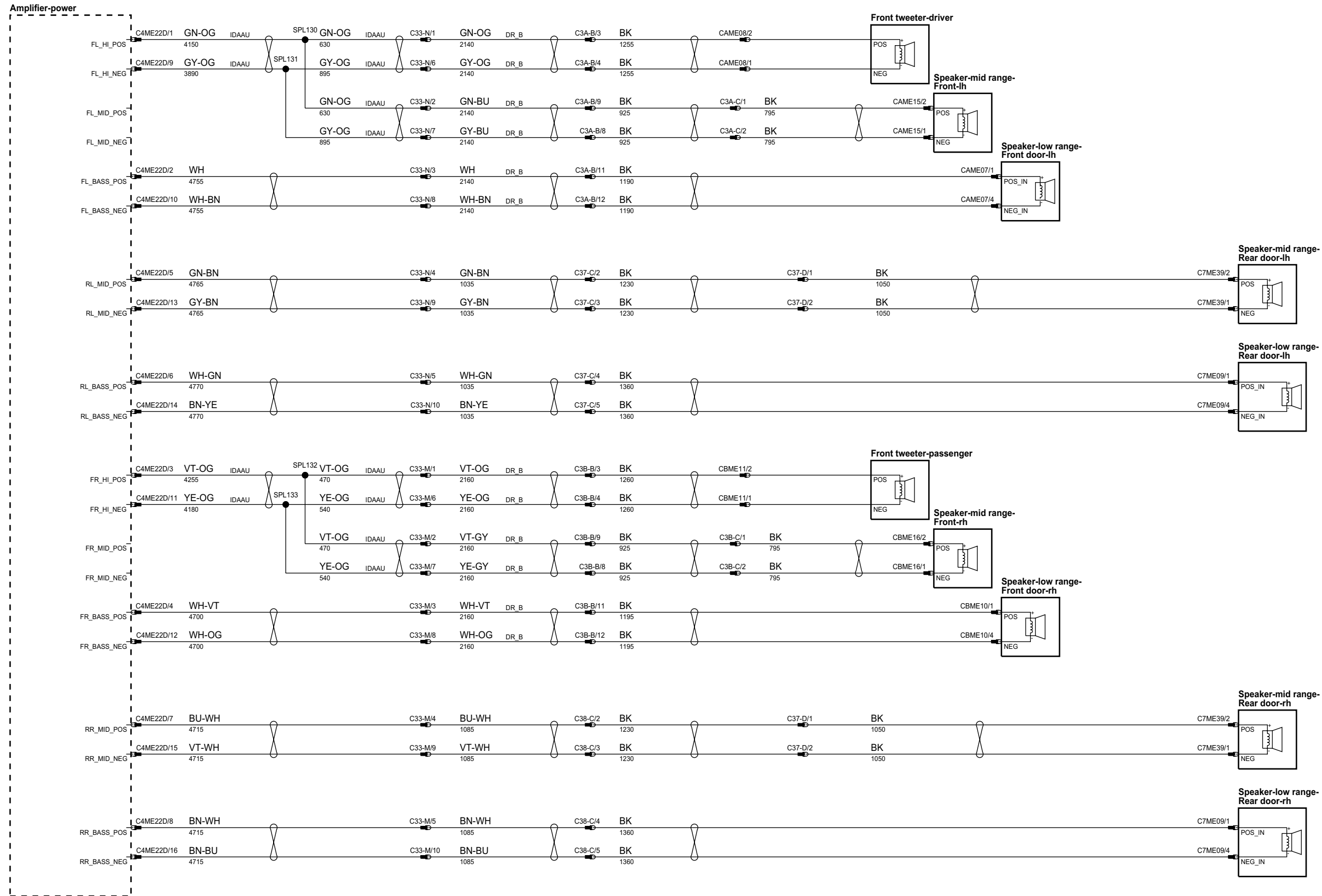

phcw93-70441-e-a3

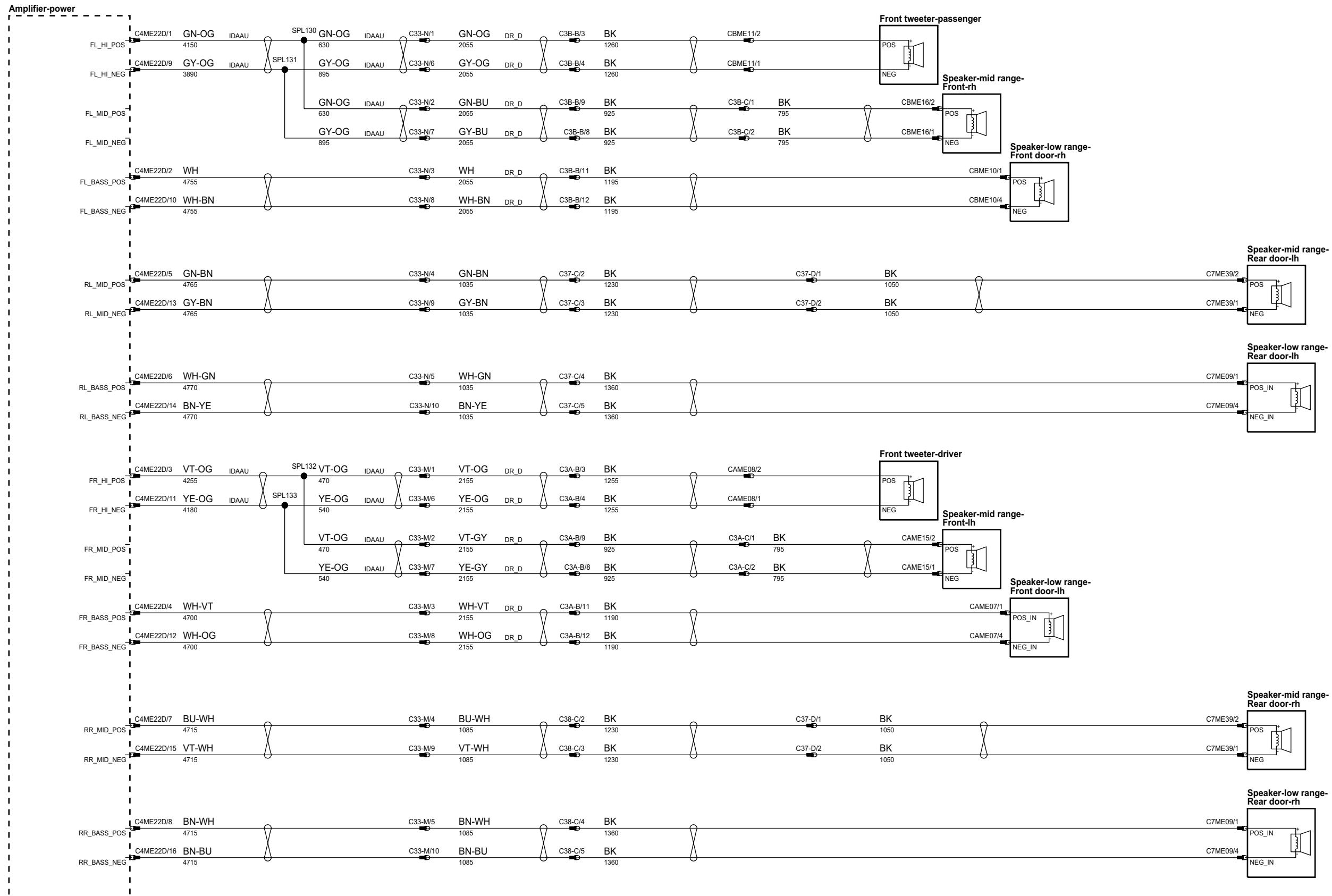

phcw93-70441-f-a3

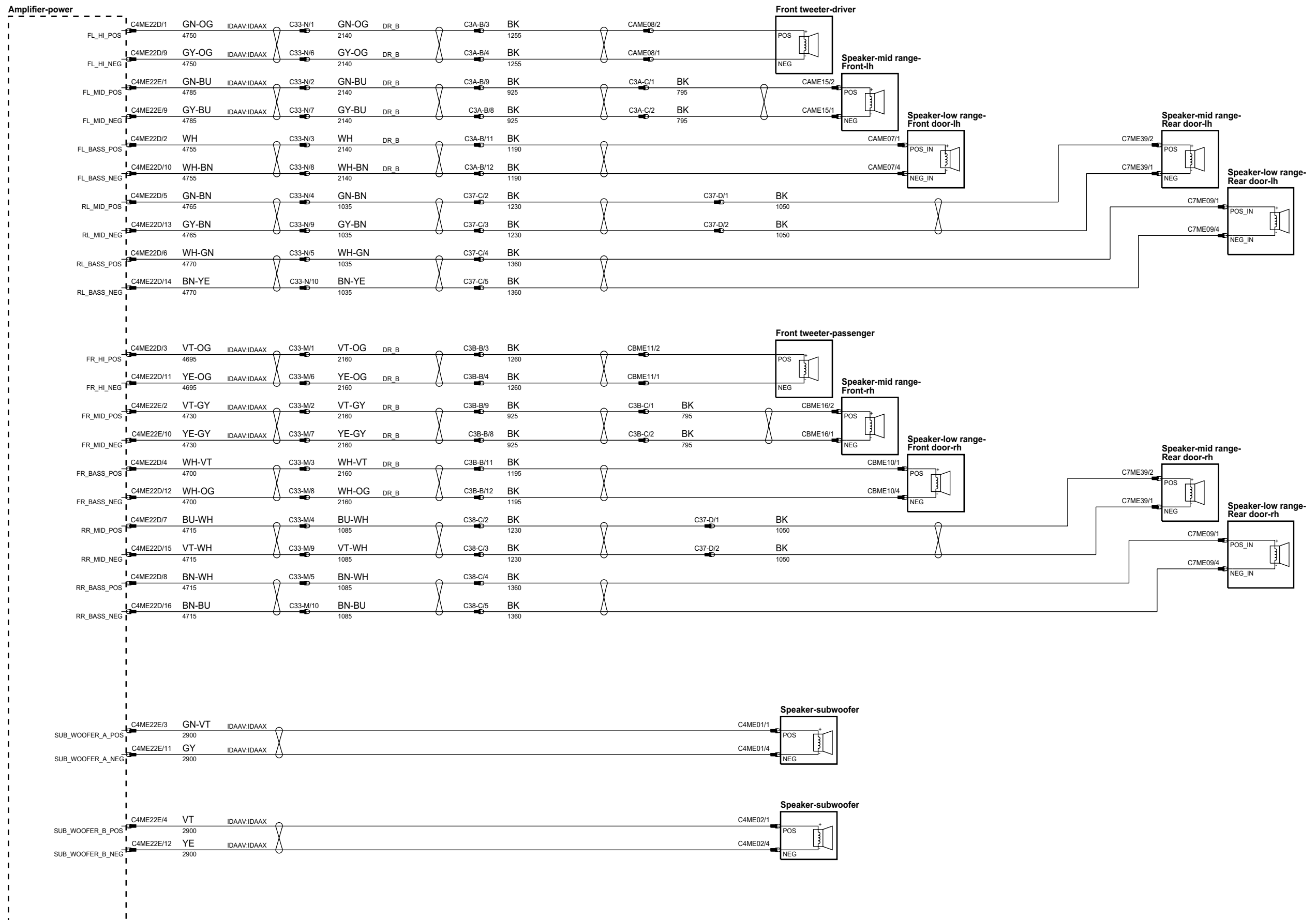

phcw93-70441-g-a3

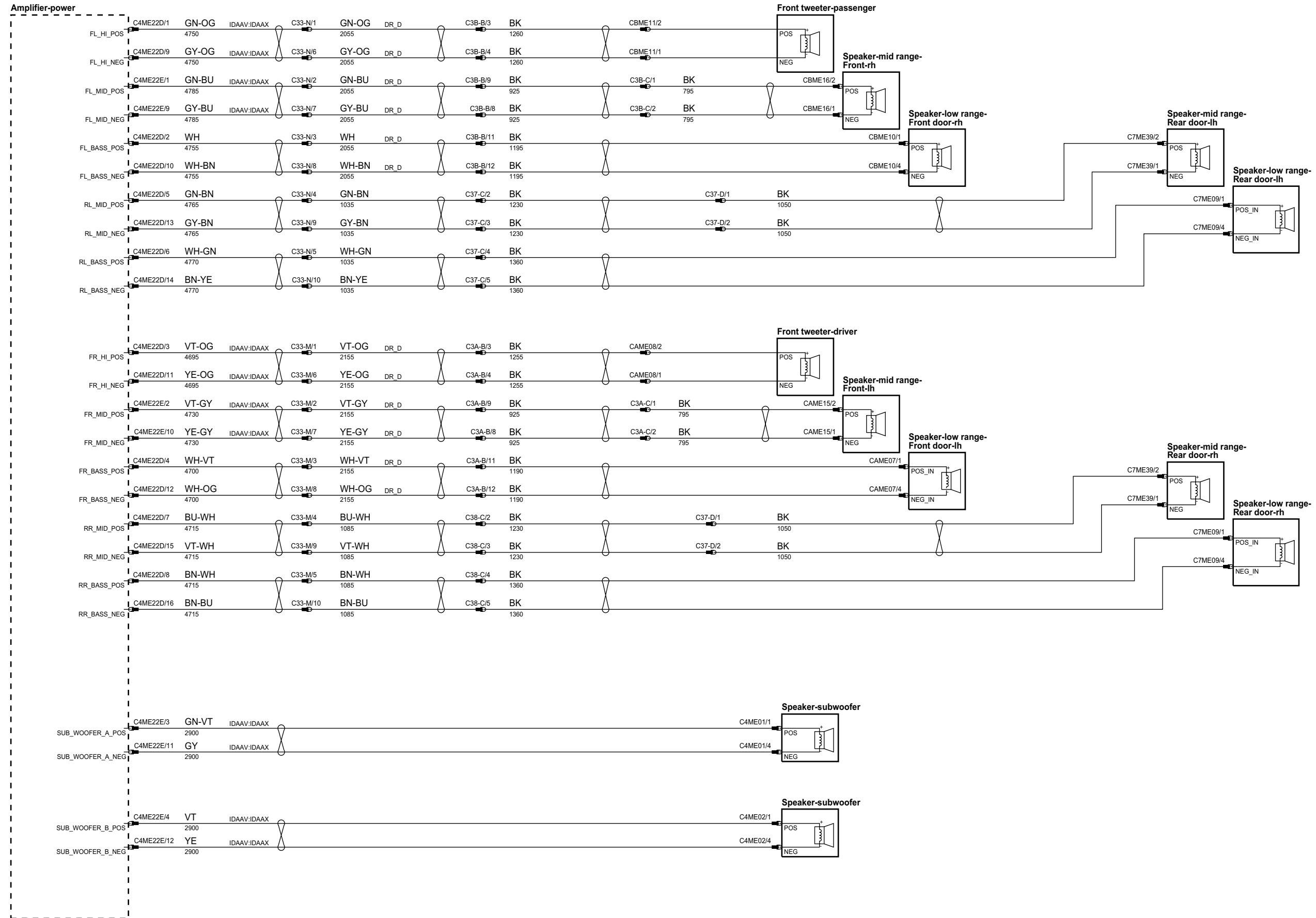

phcw93-70441-h-a3

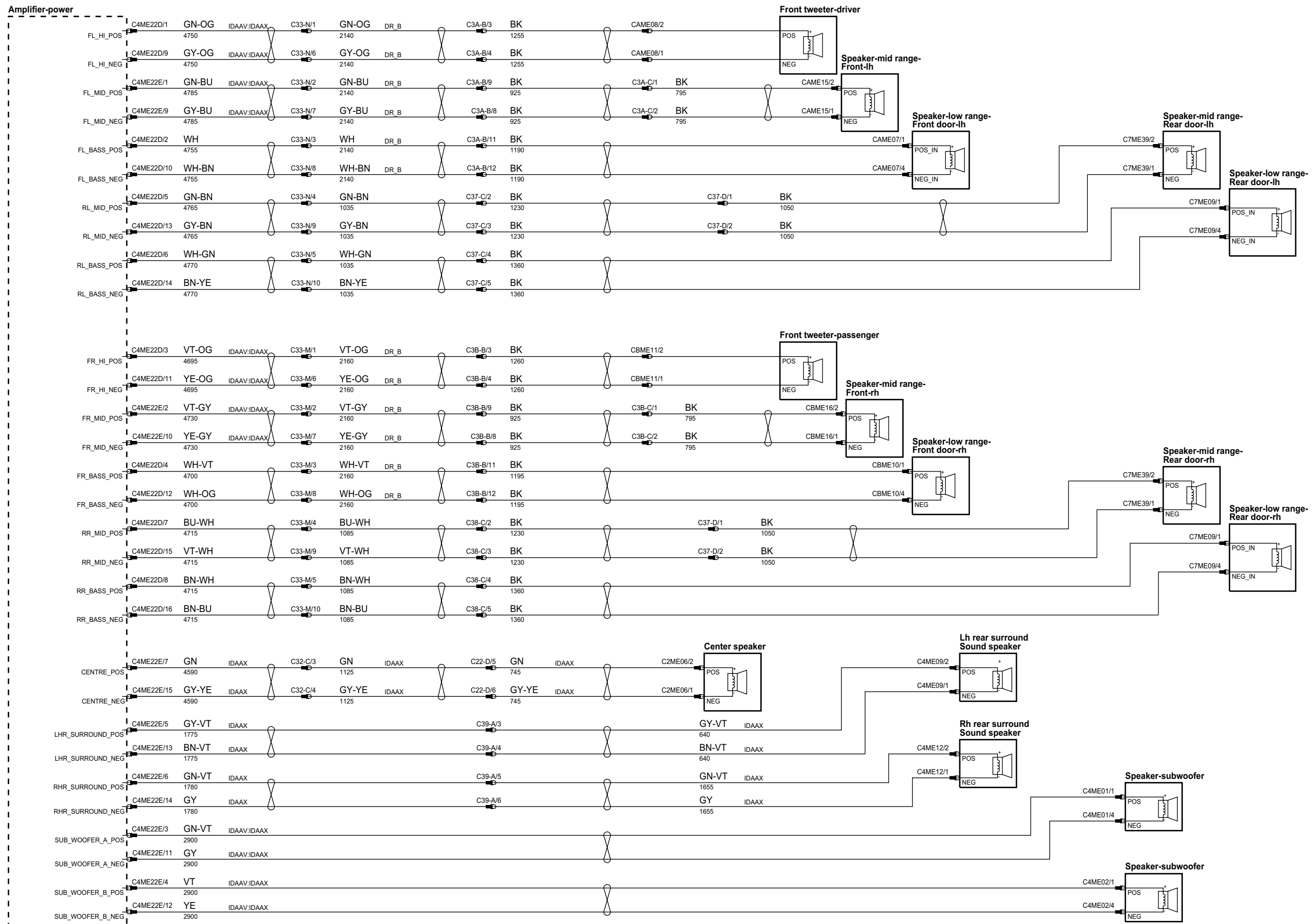

phcw93-70441-j-a3

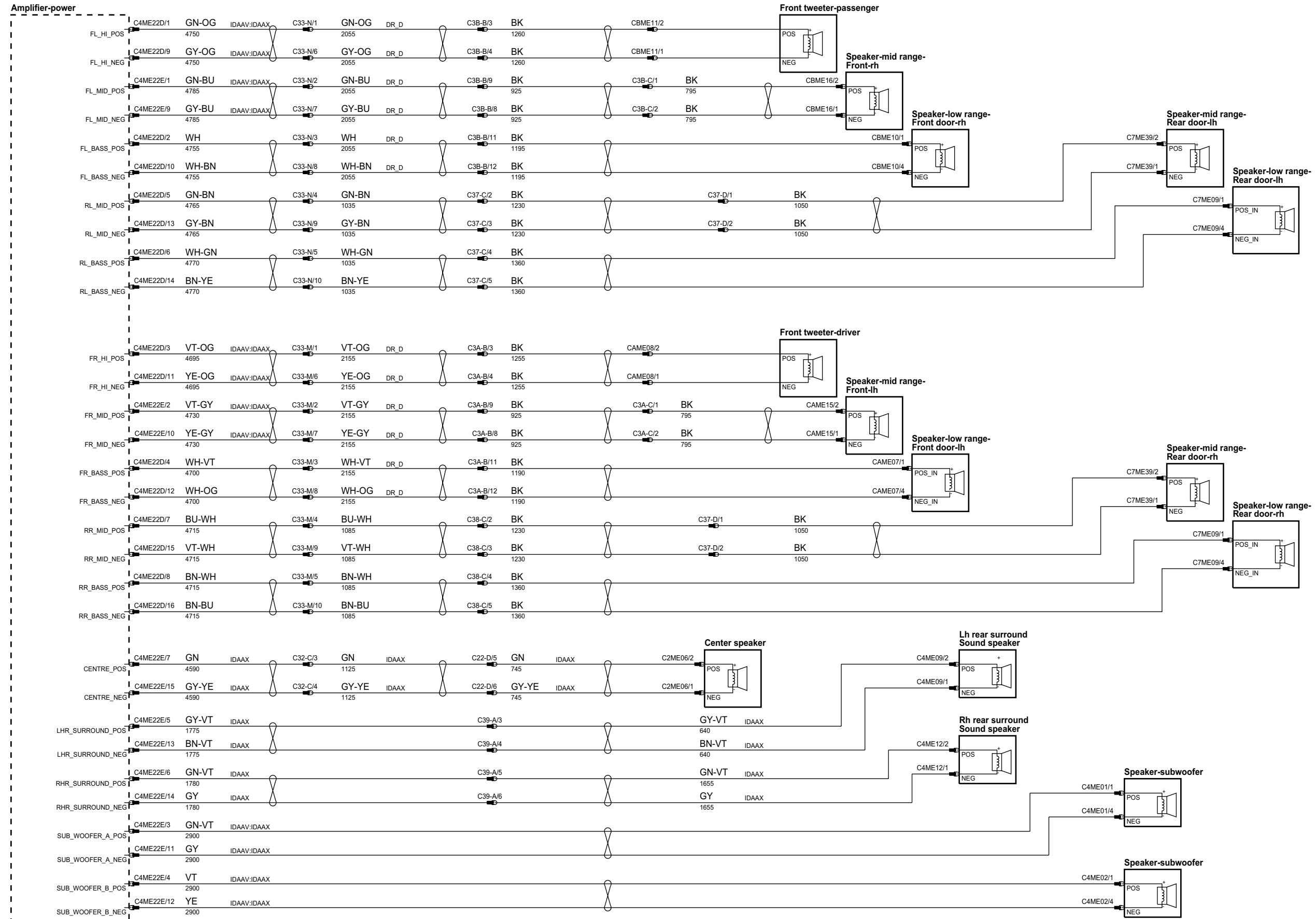

phcw93-70447-a-a3

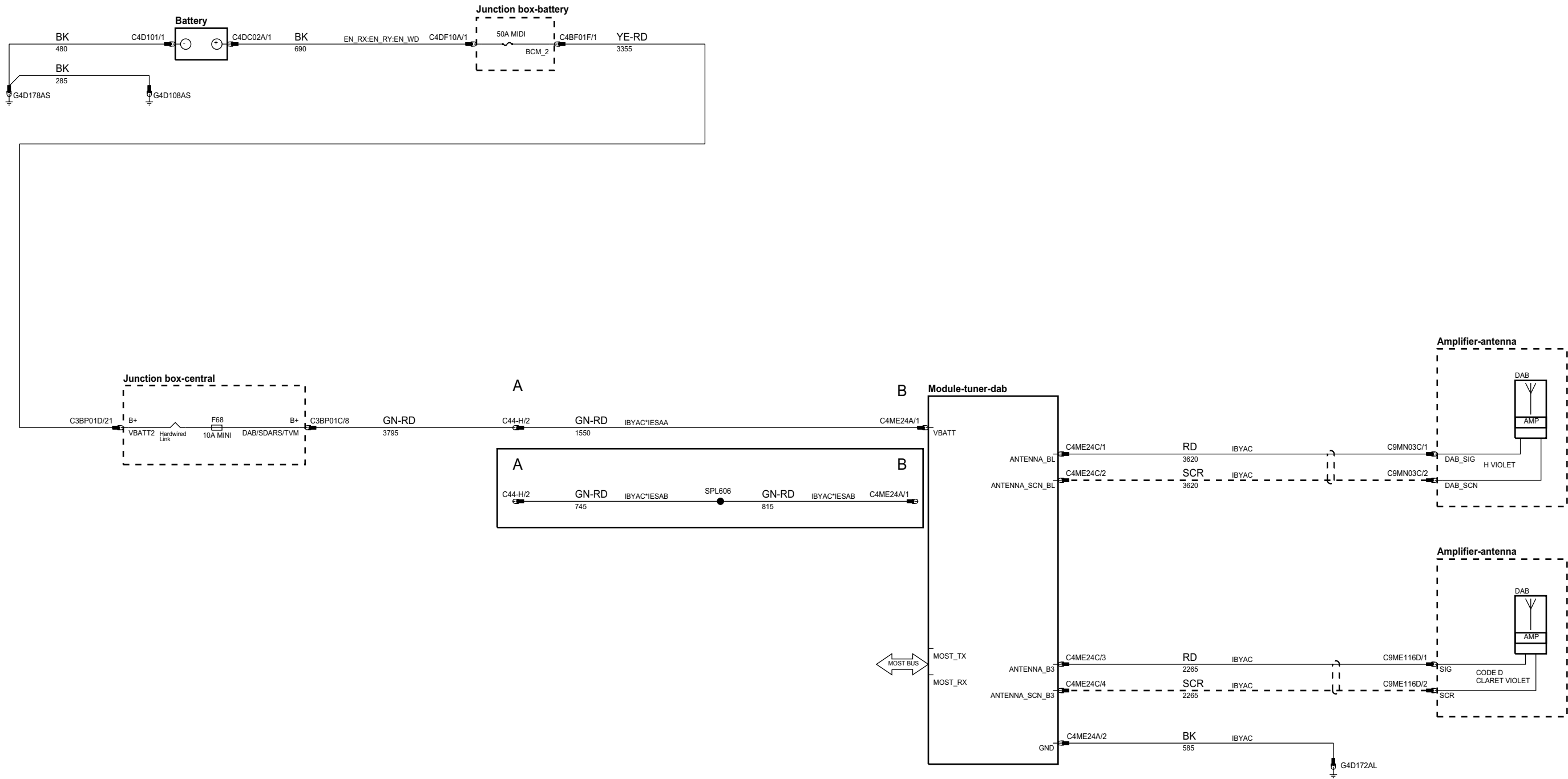

phcw93-70447-b-a3

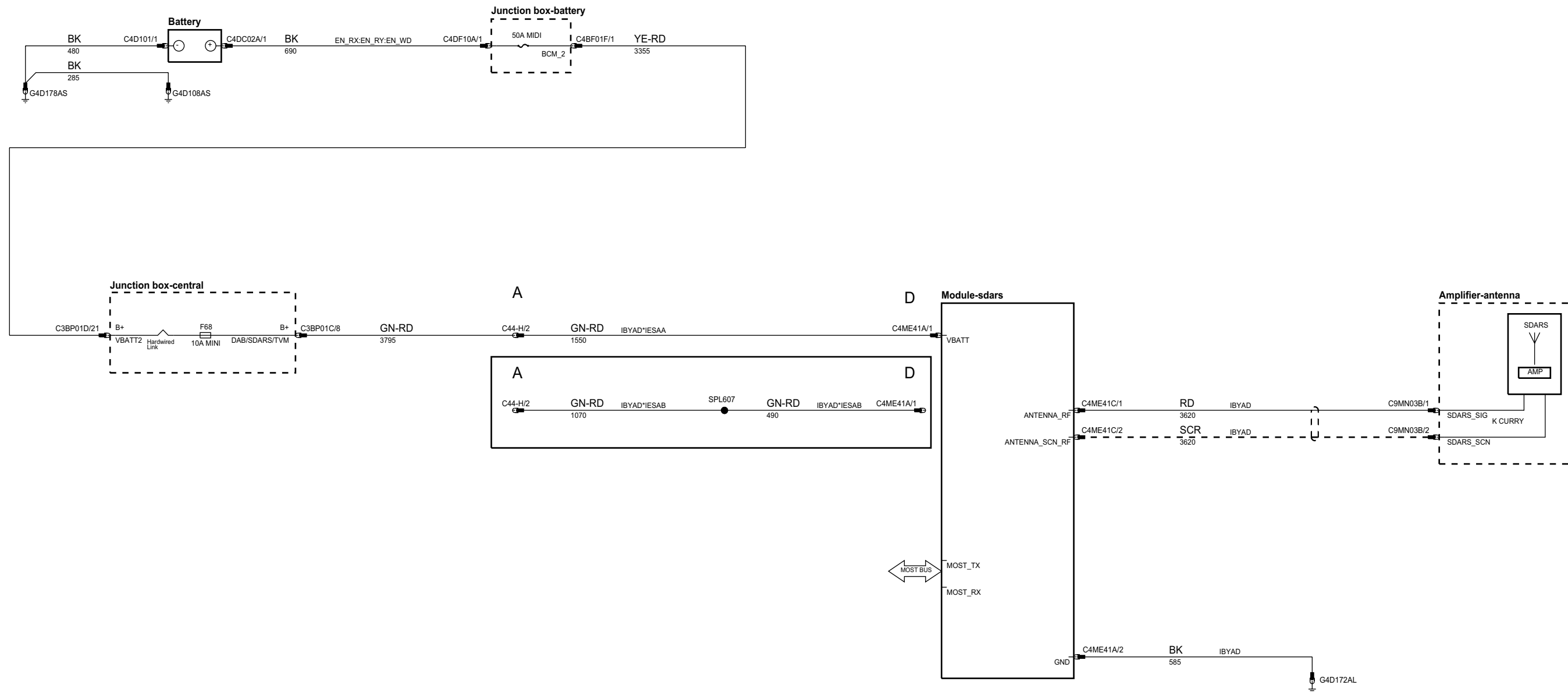

phcw93-70456-a-a3

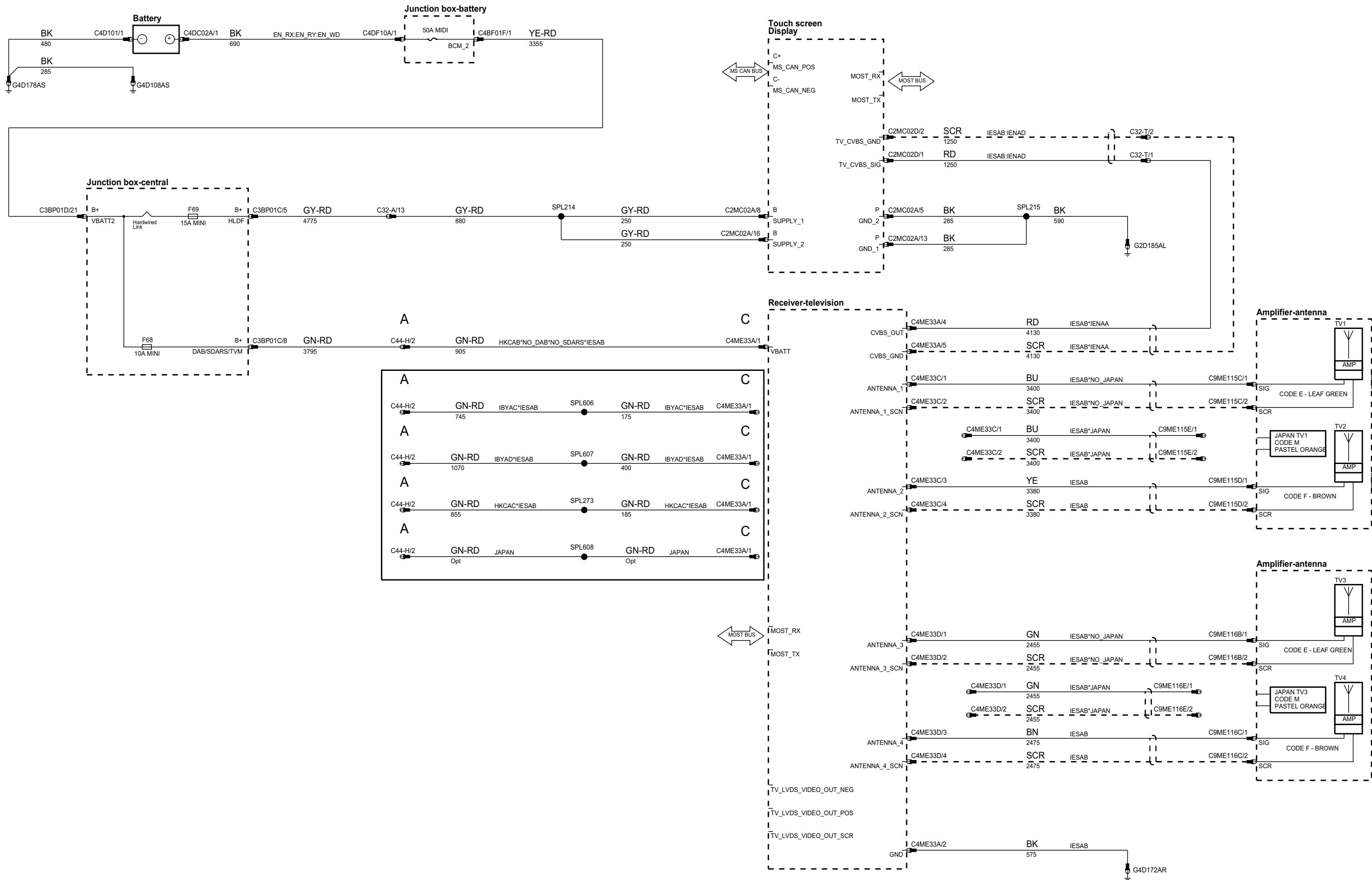

phcw93-70455-a-a3

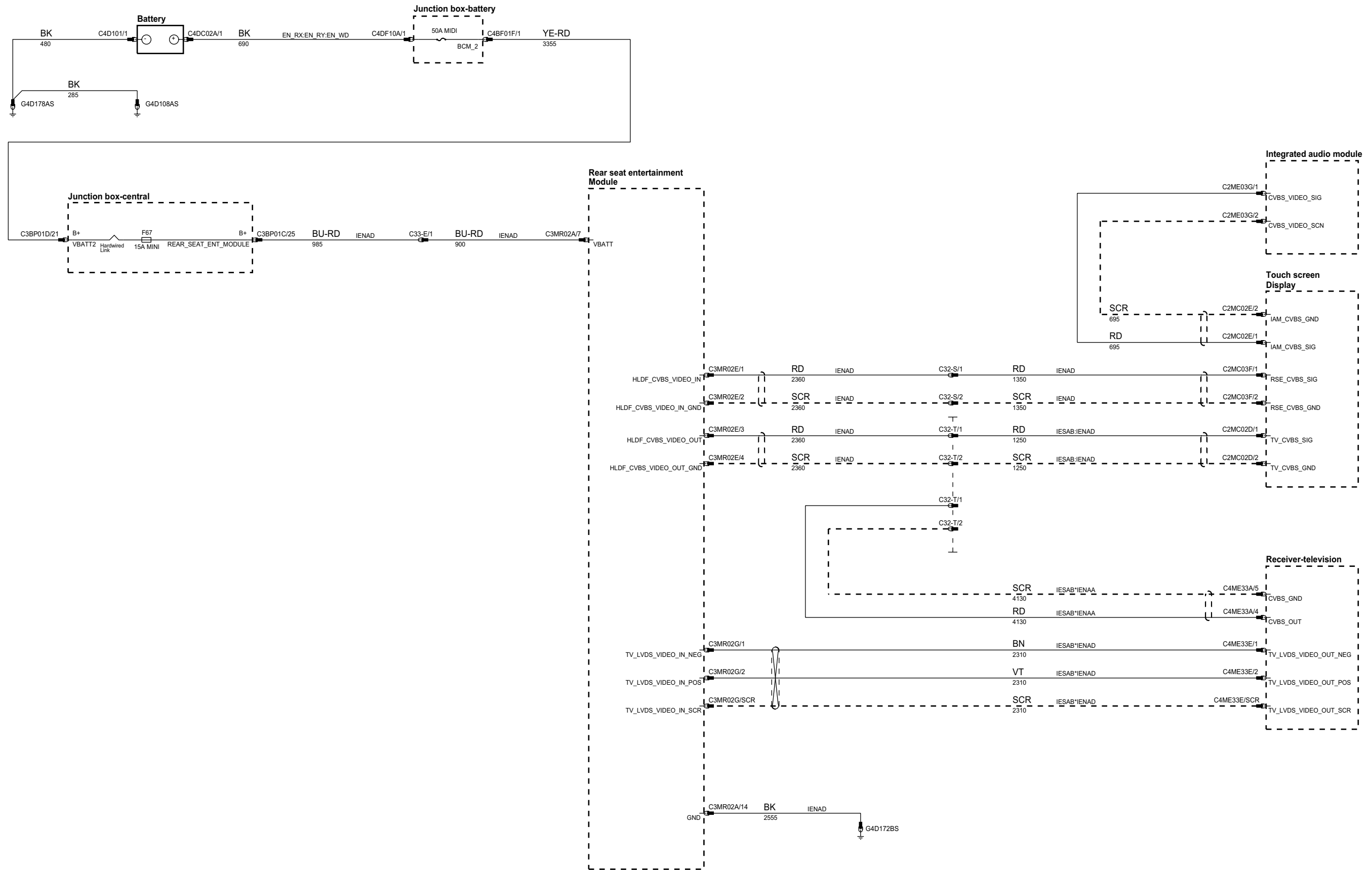

phcw93-70455-b-a3

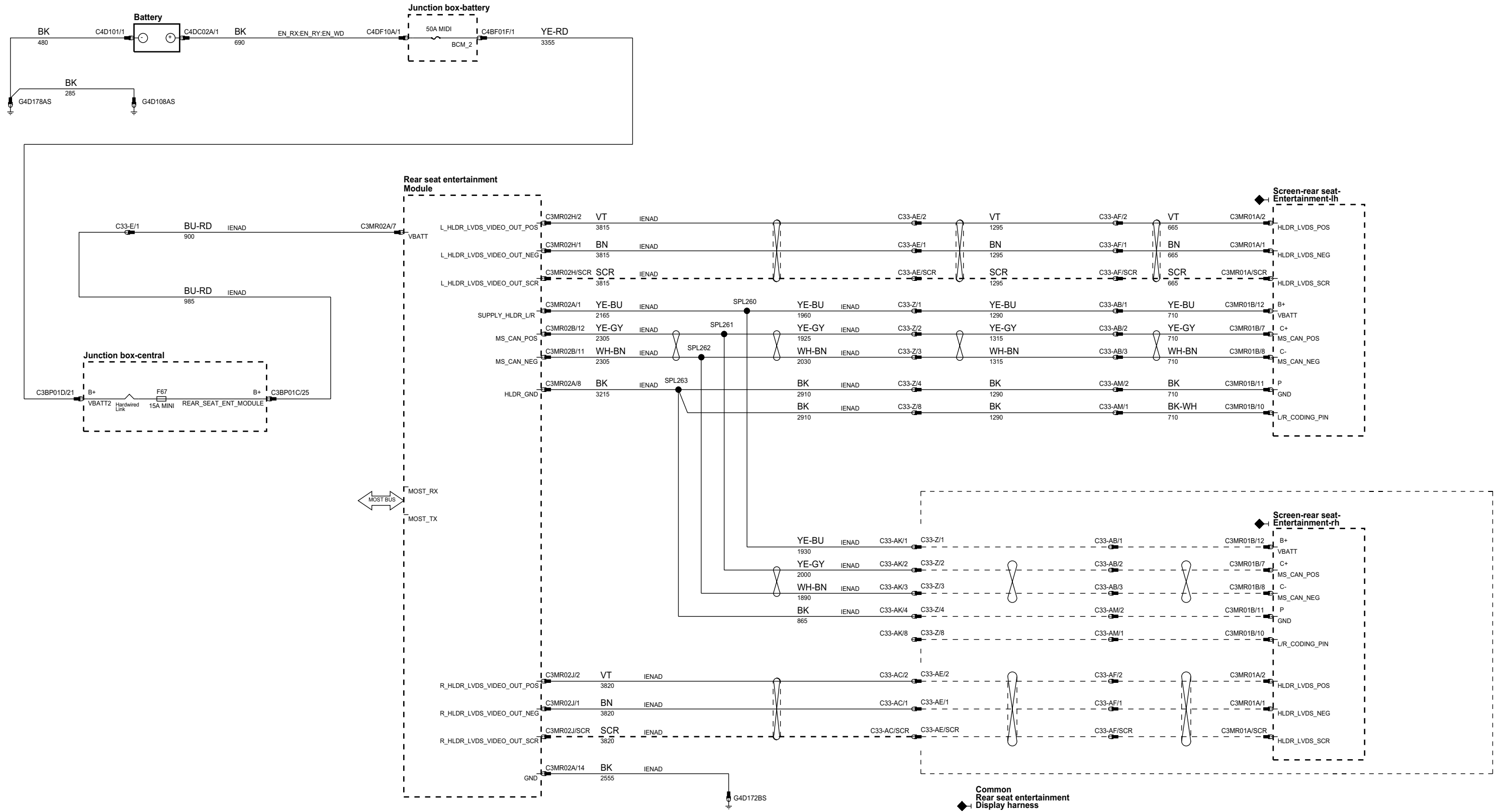

phcw93-70455-c-a3

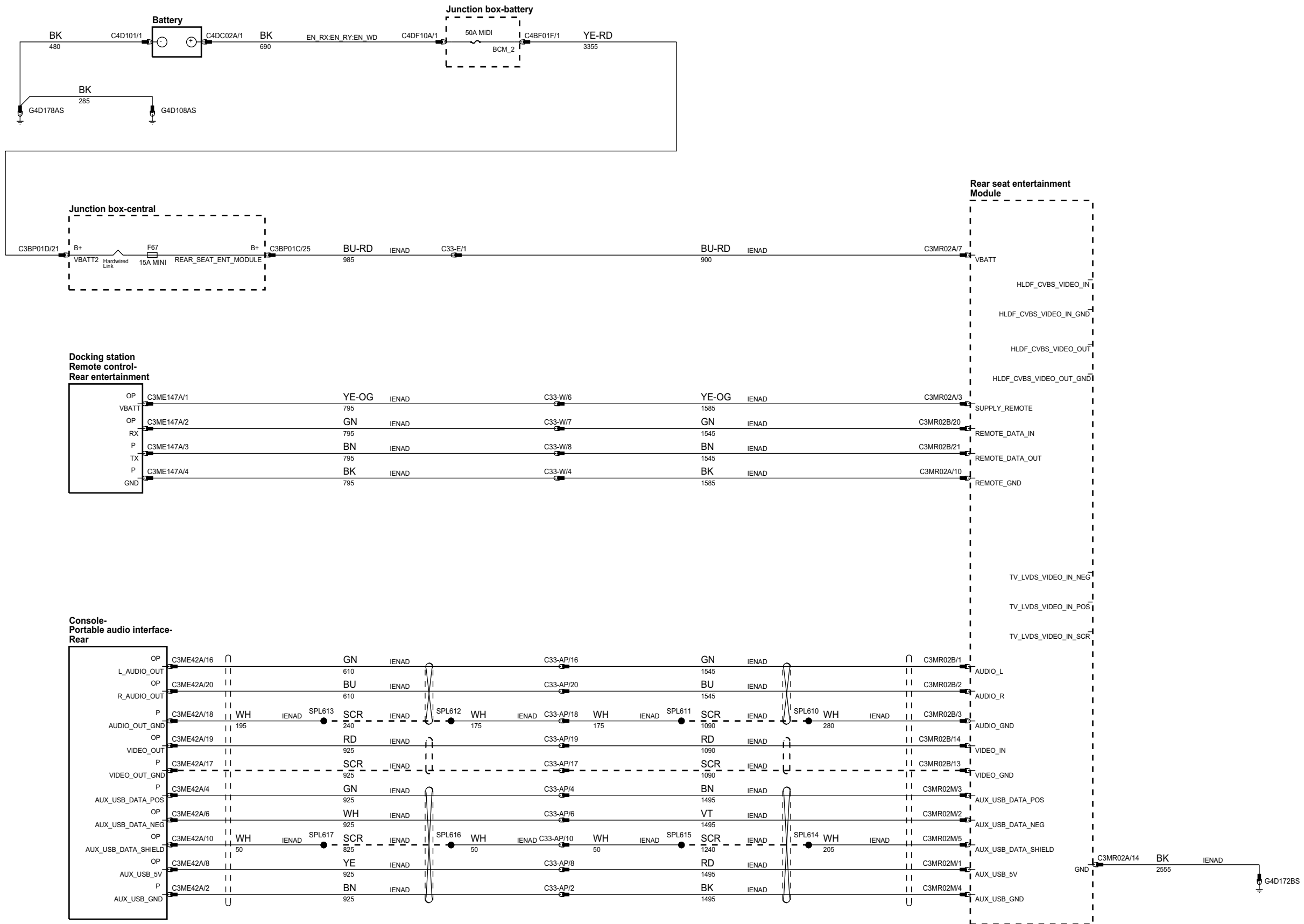

phcw93-70061-a-a3

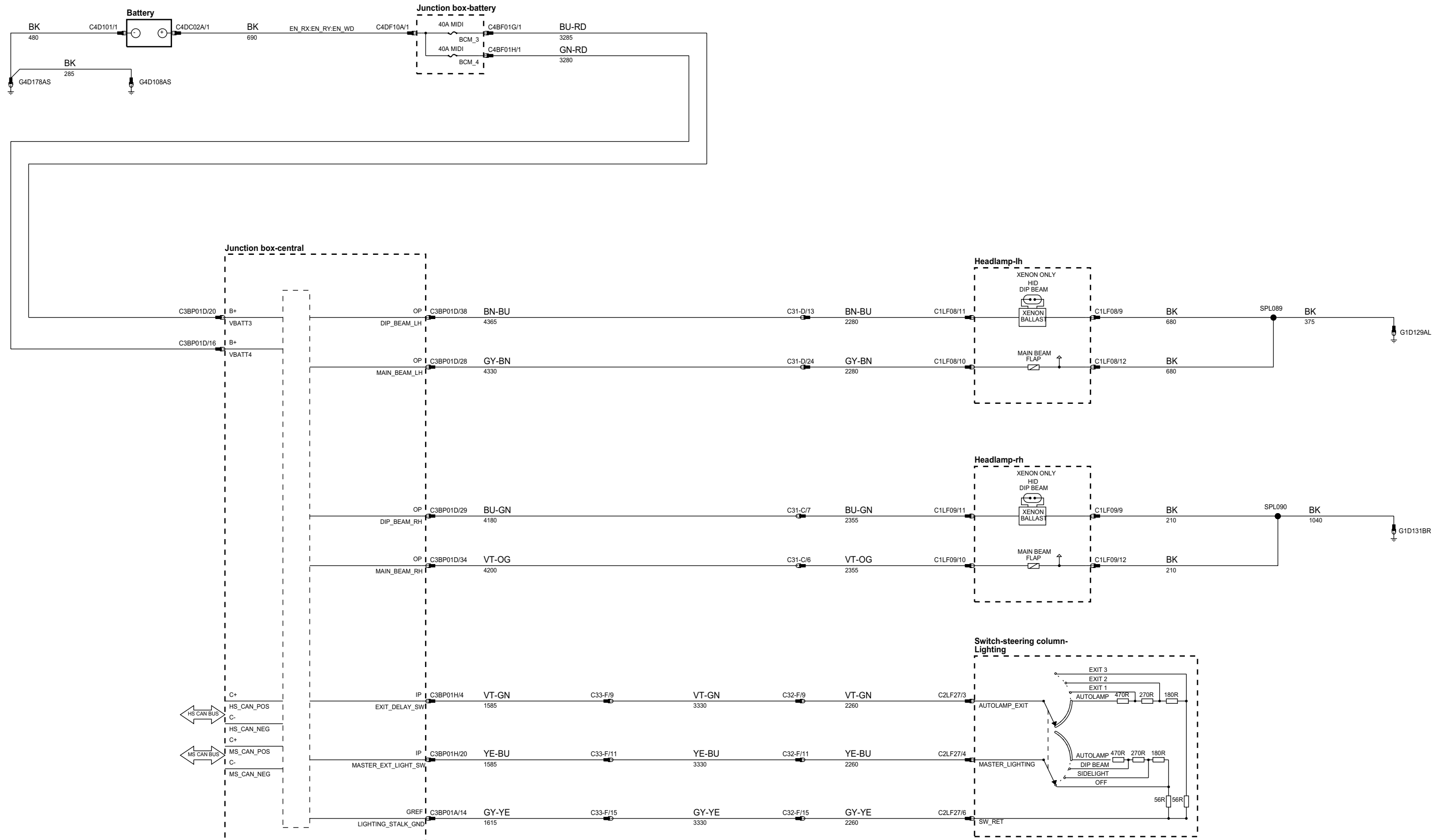

phcw93-70061-b-a3

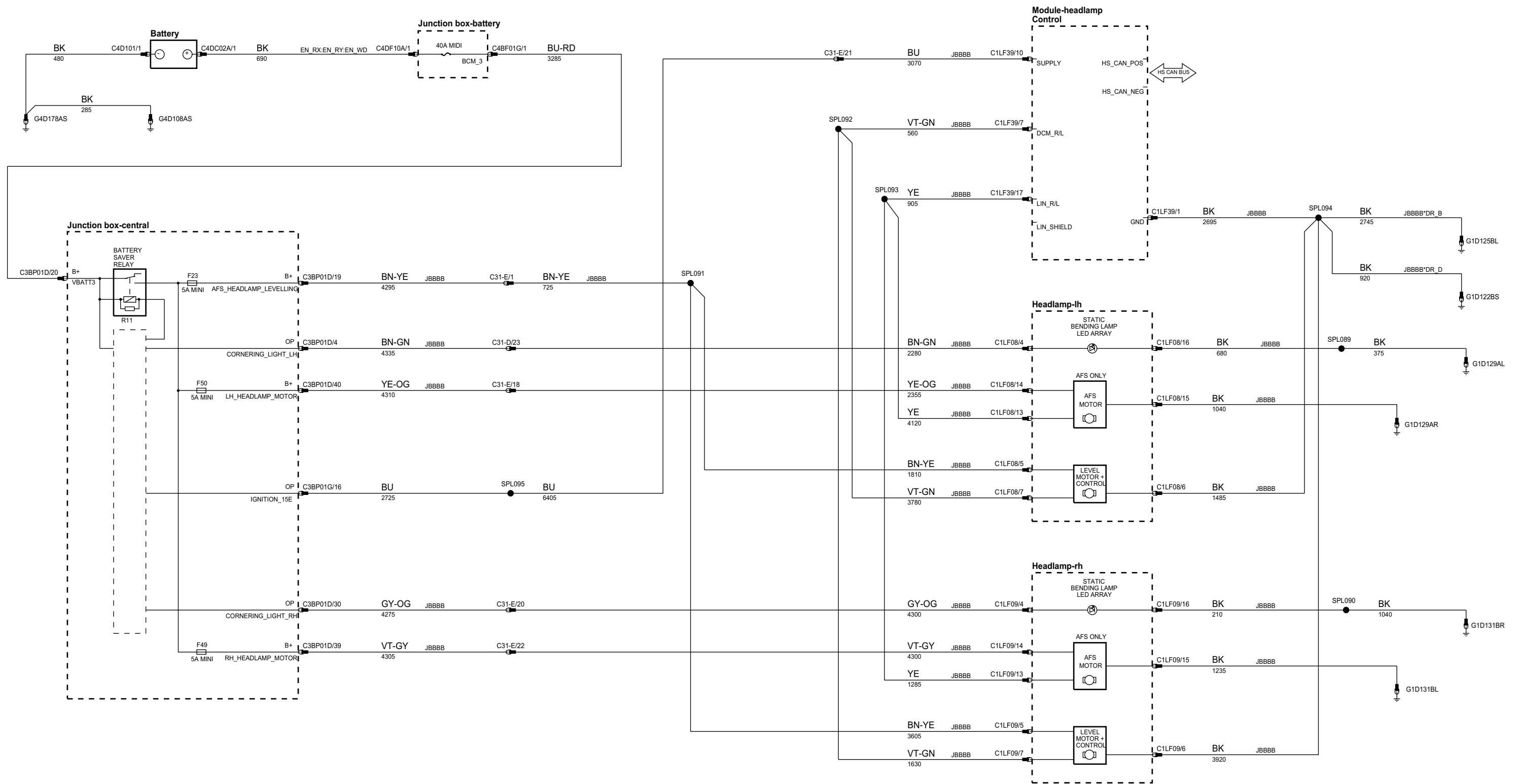

phcw93-70086-a-a3

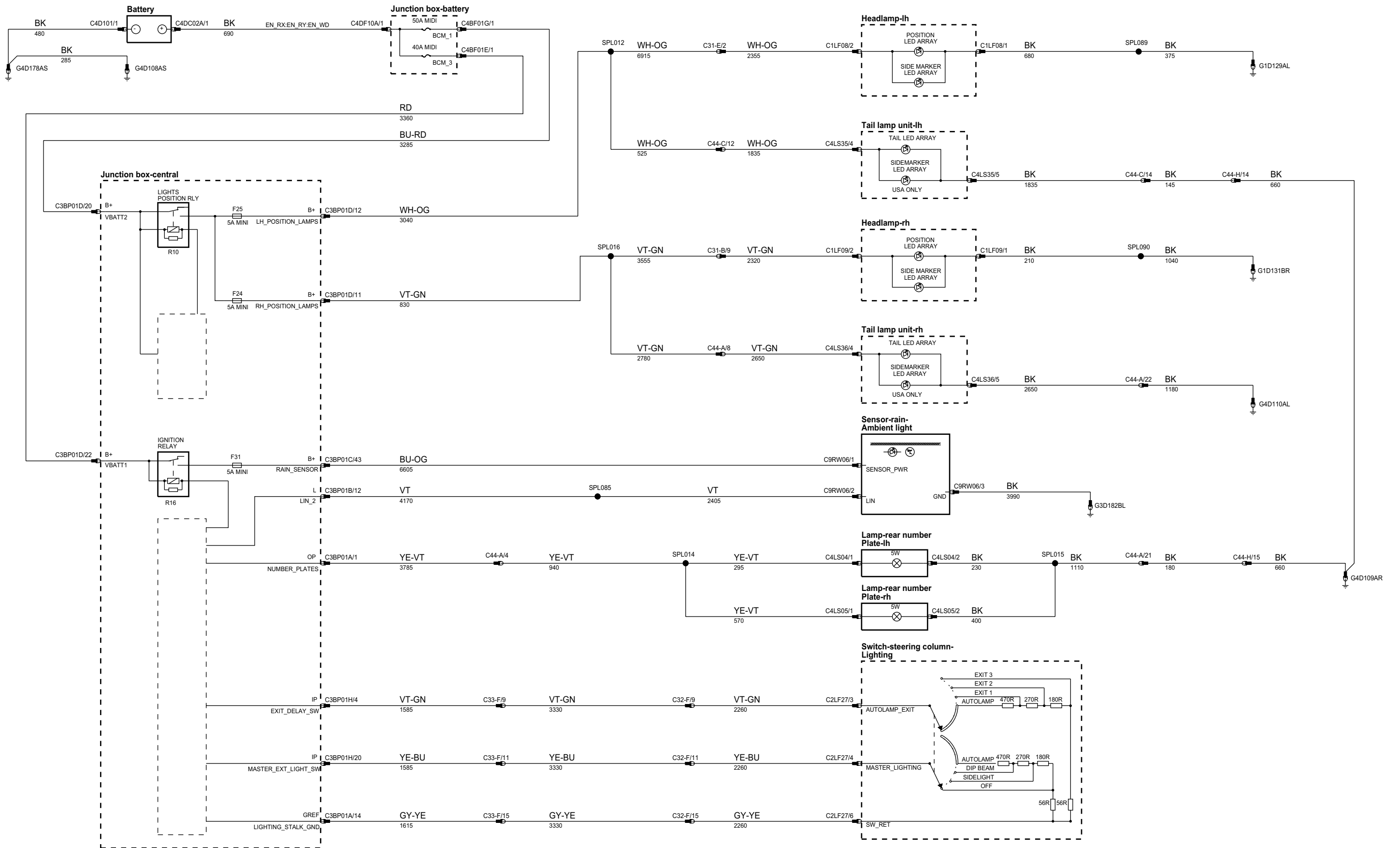

phcw93-70072-a-a3

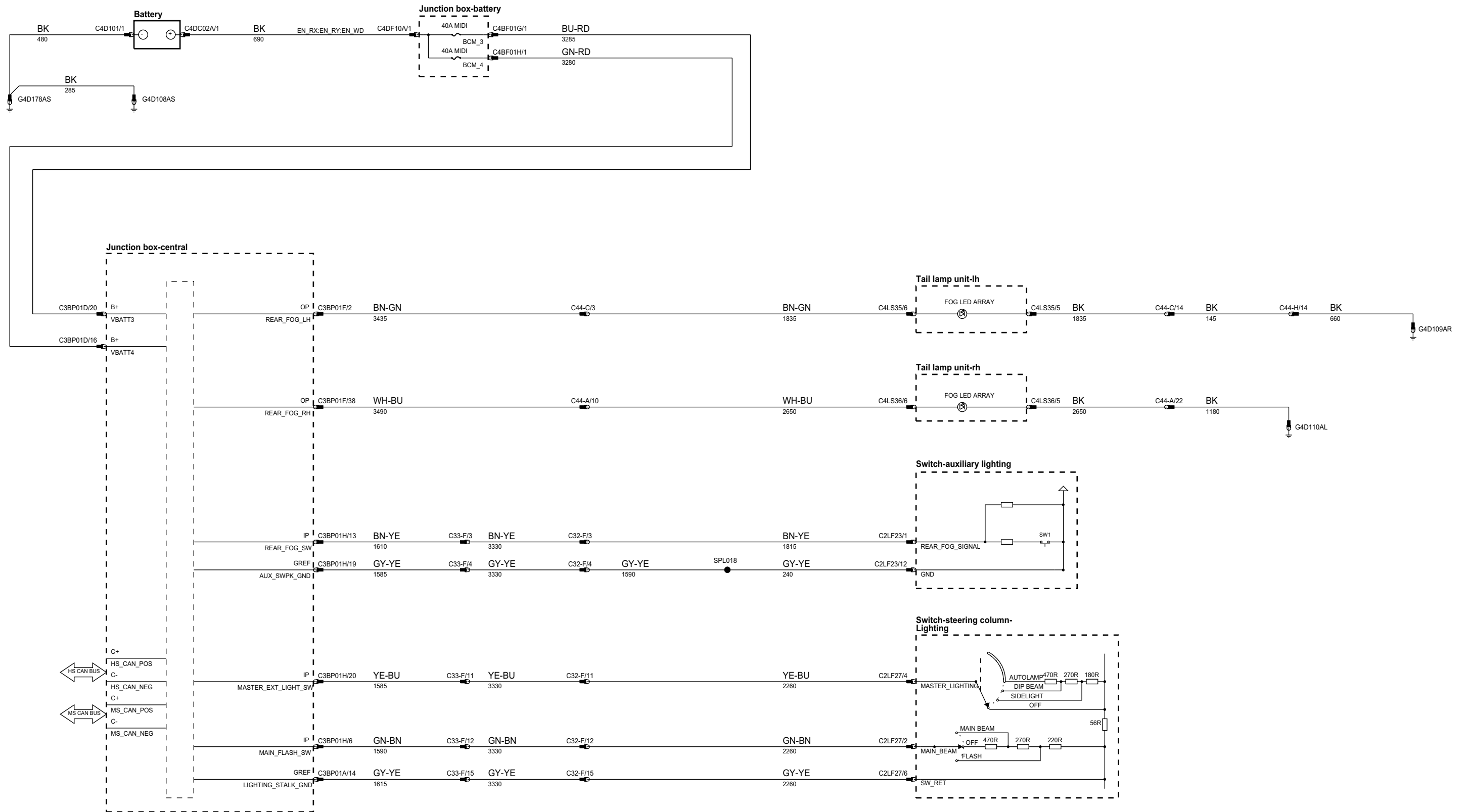

x

phcw93-70075-a-a3

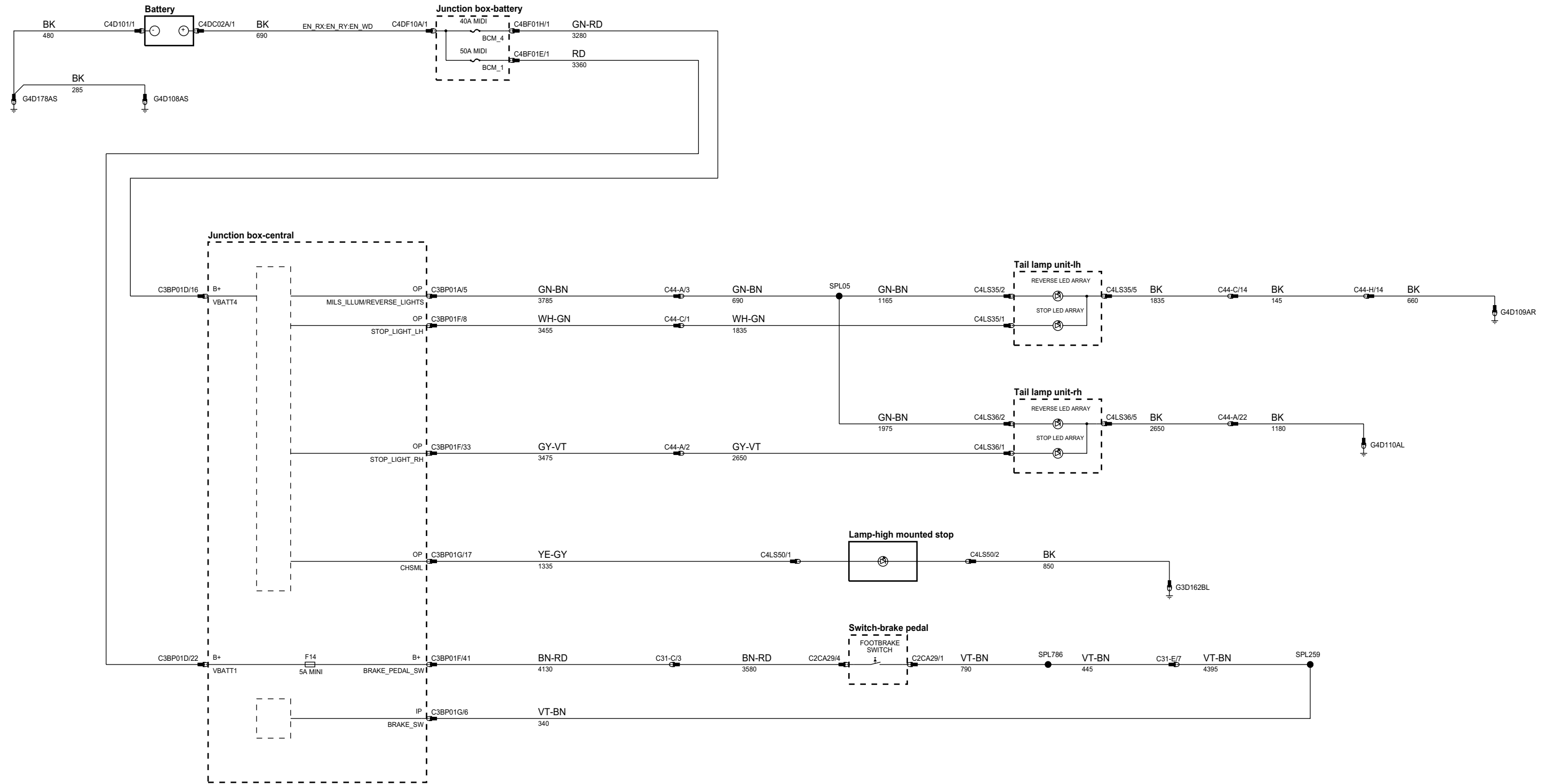

phcw93-70078-a-a3

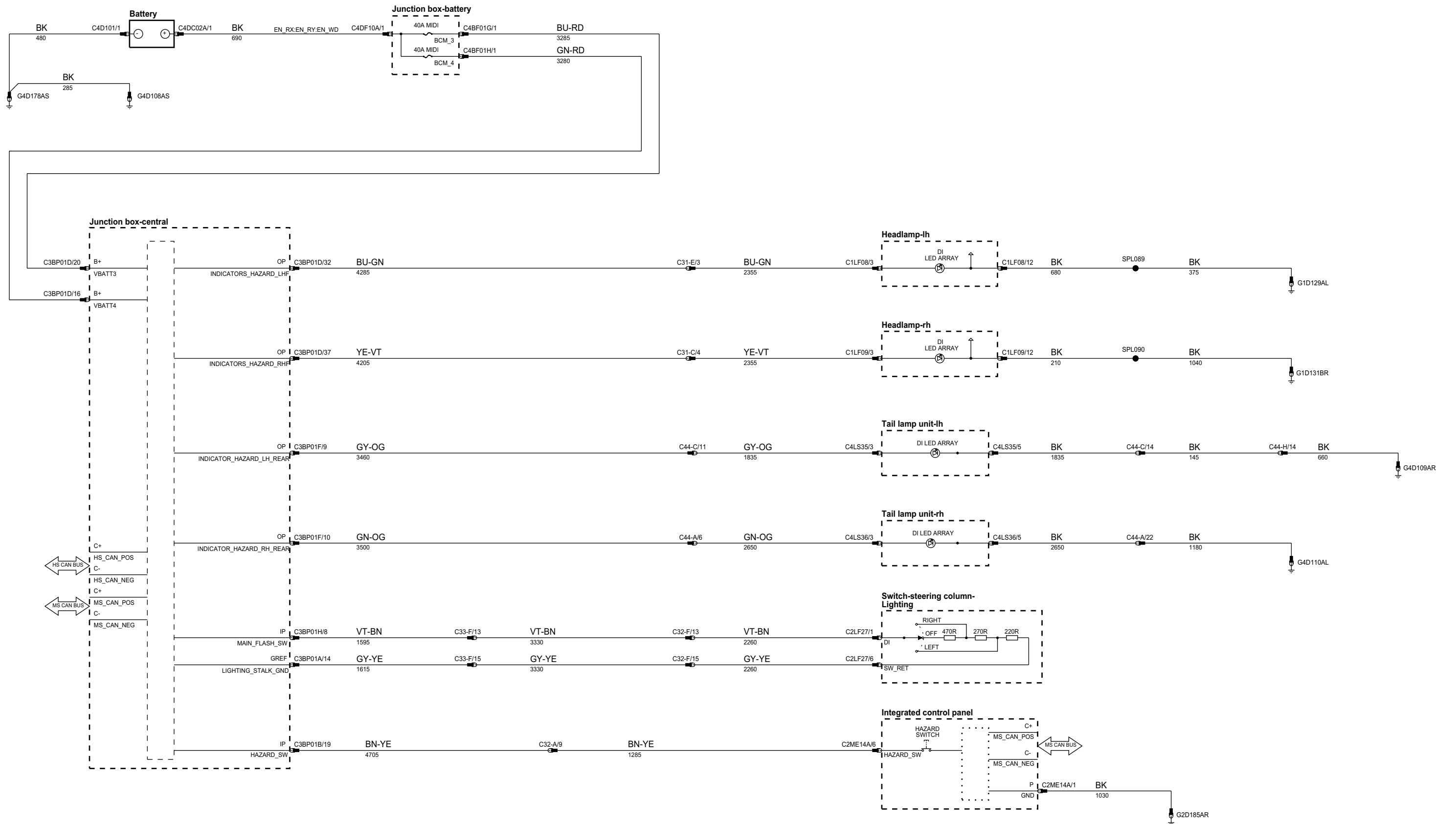

phcw93-70080-a-a3

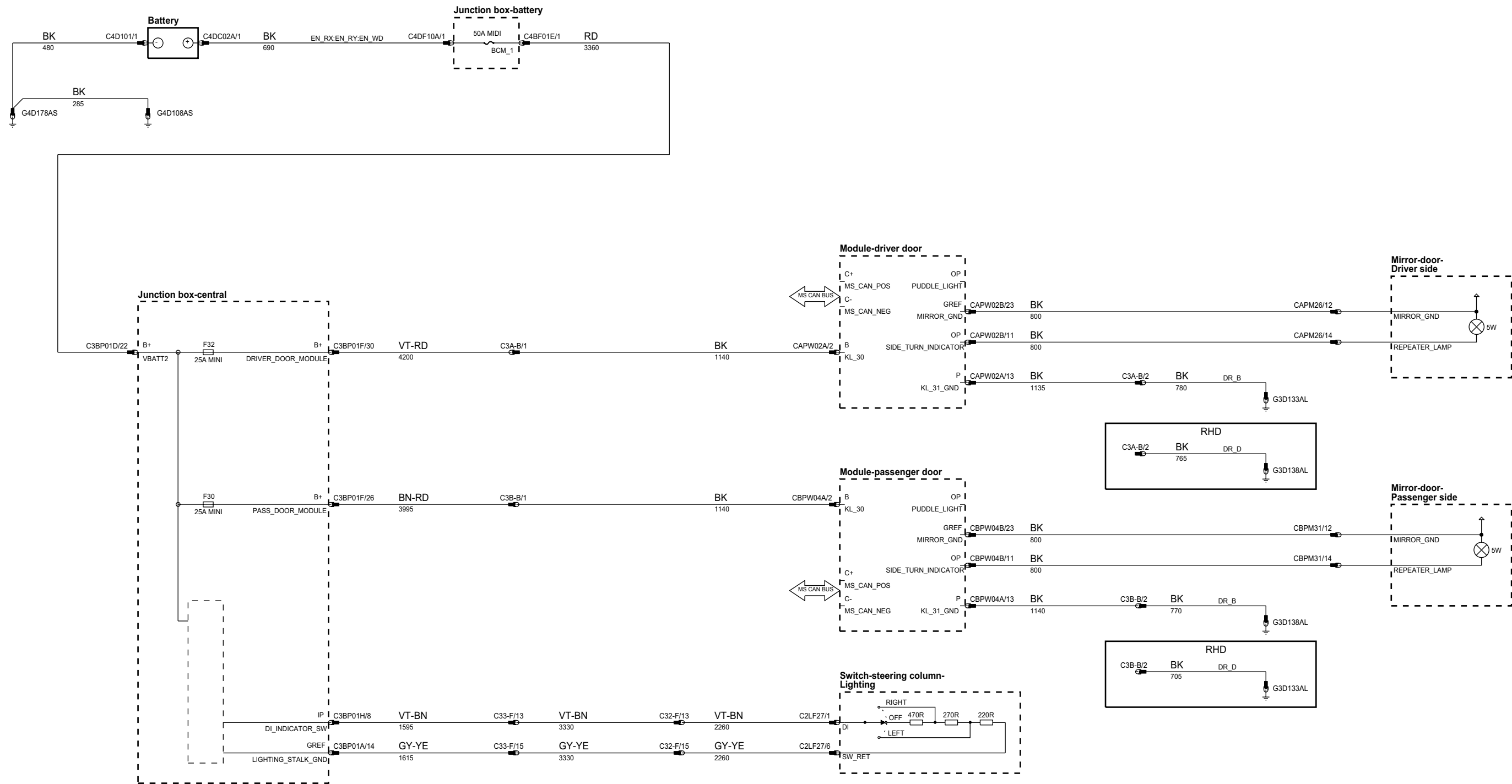

phcw93-70101-a-a3

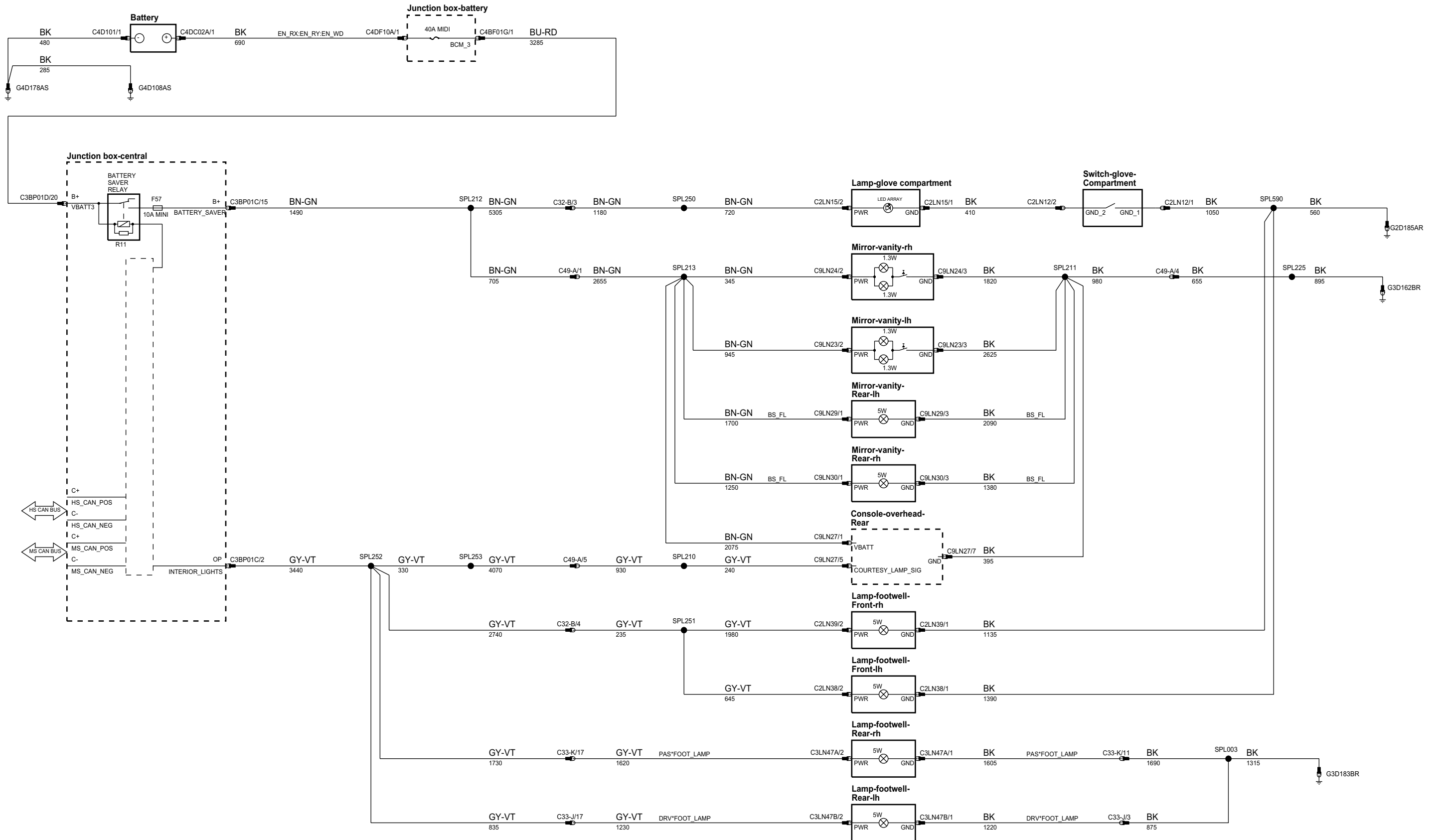

phcw93-70101-b-a3

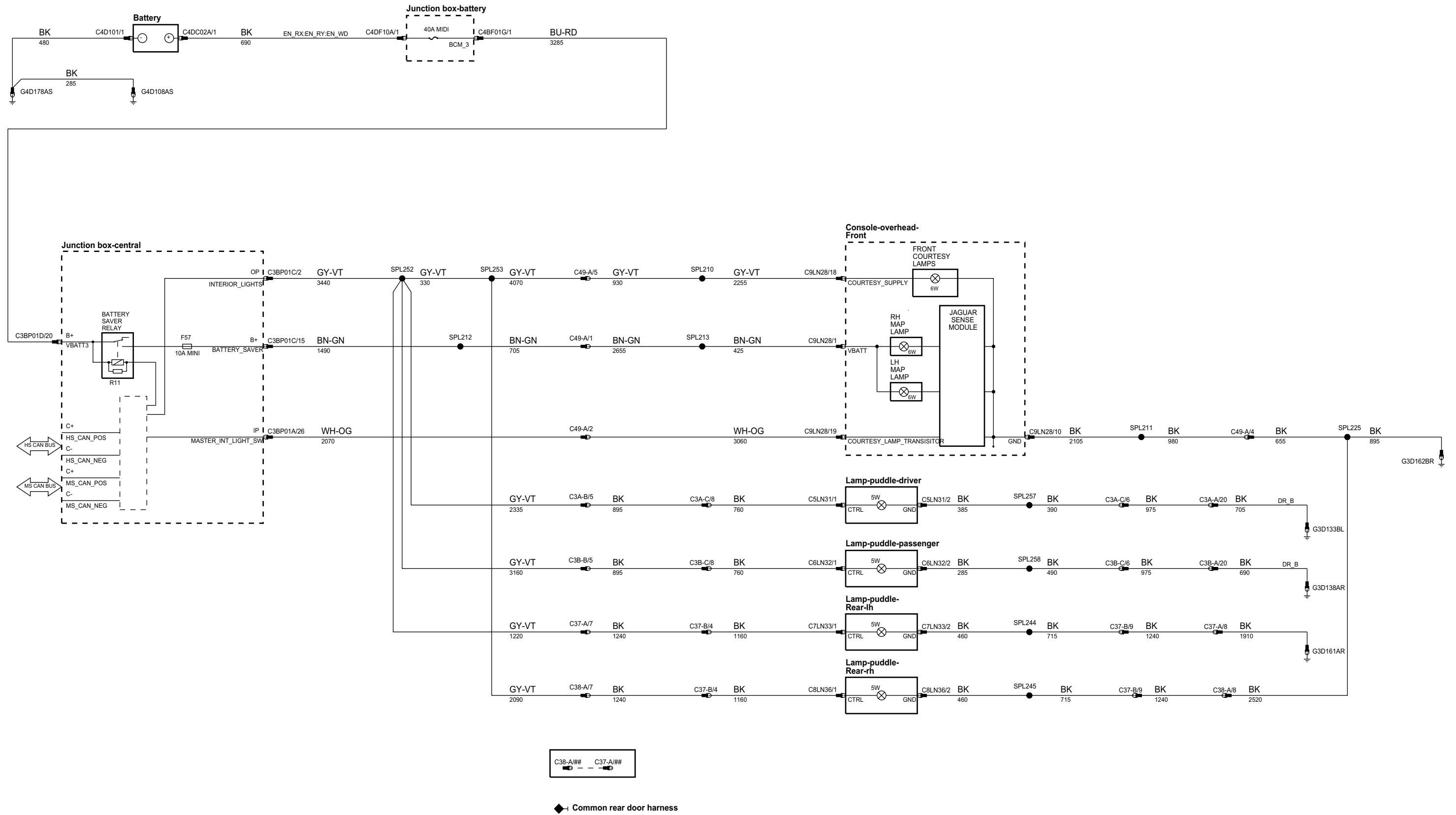

phcw93-70101-c-a3

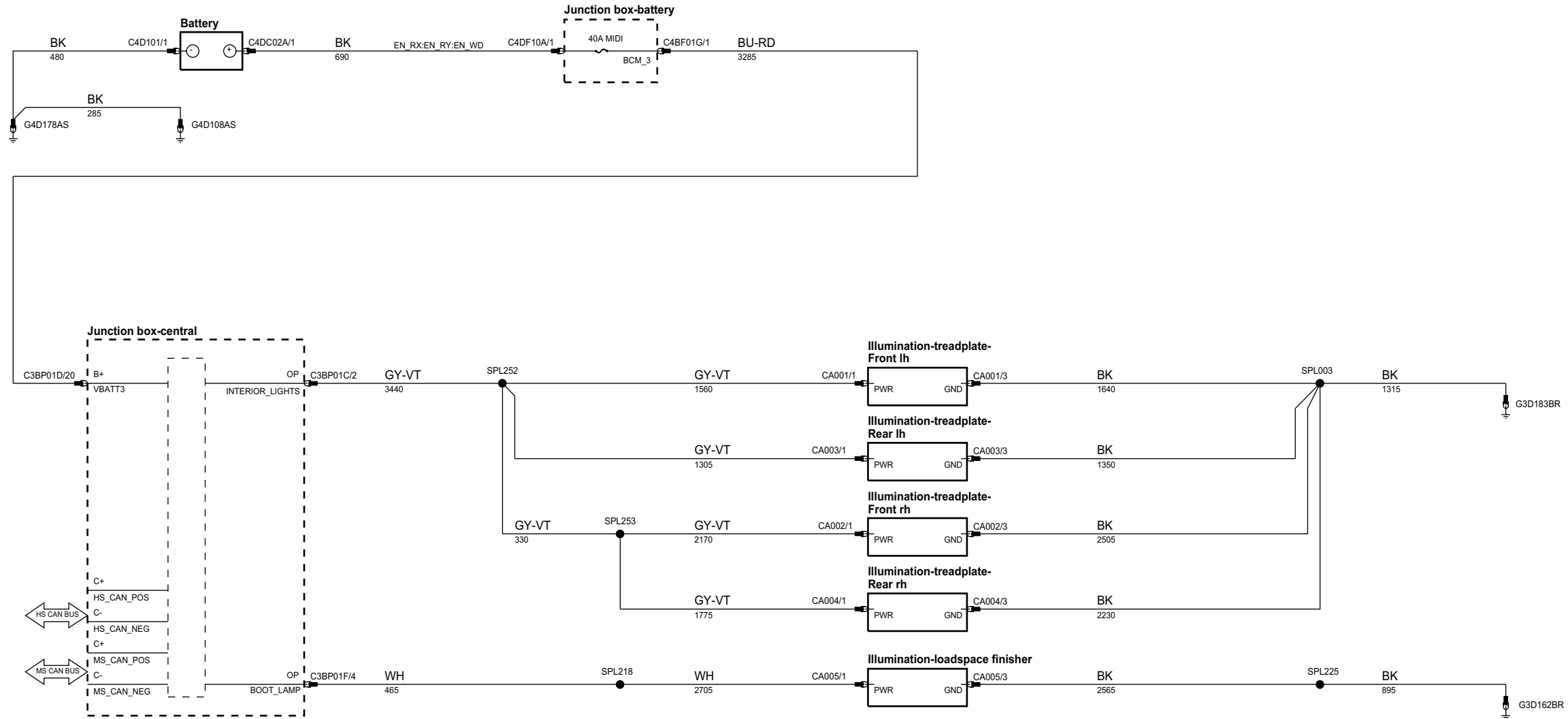

x

phcw93-70104-a-a3

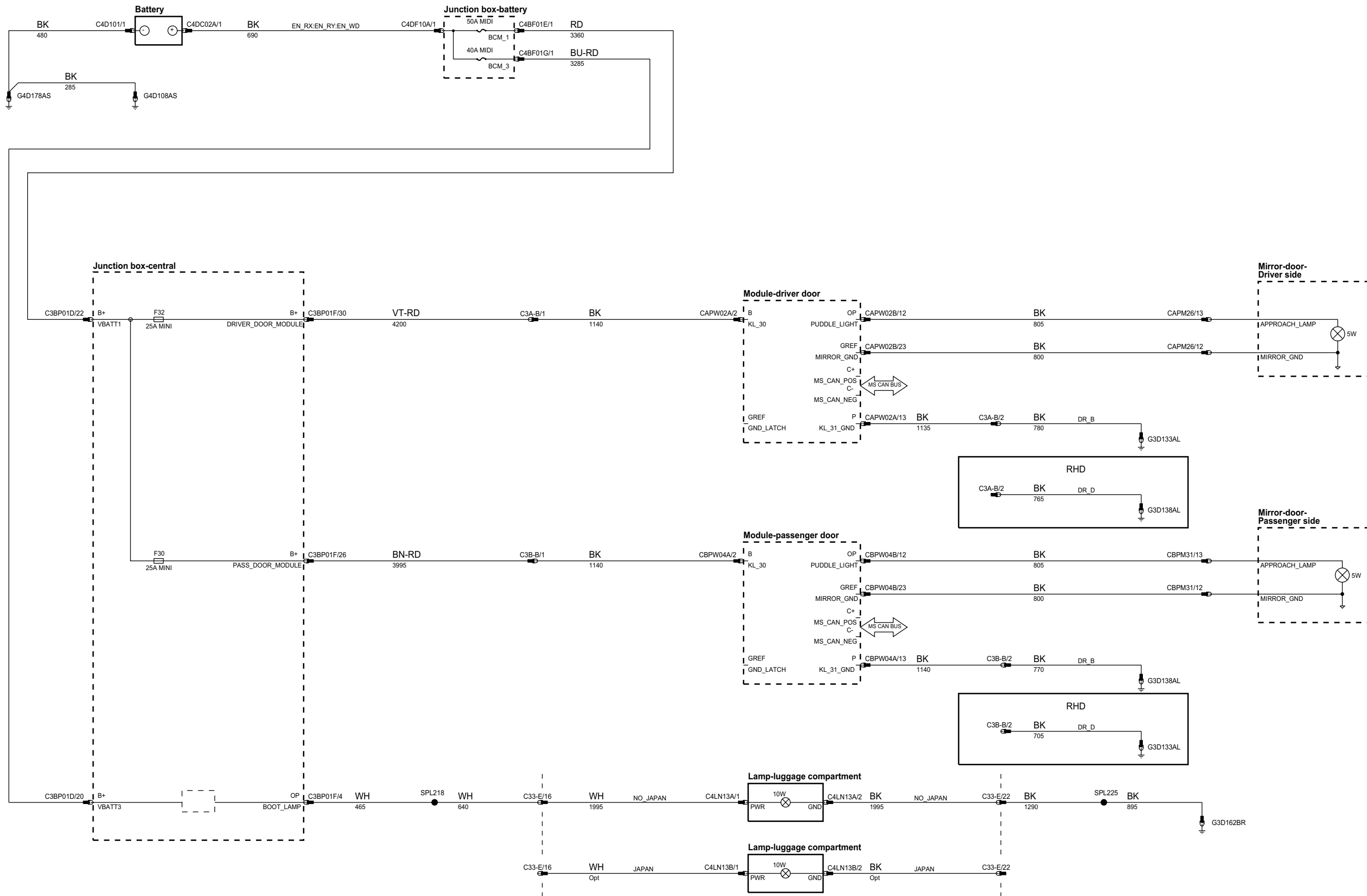

phcw93-70106-a-a3

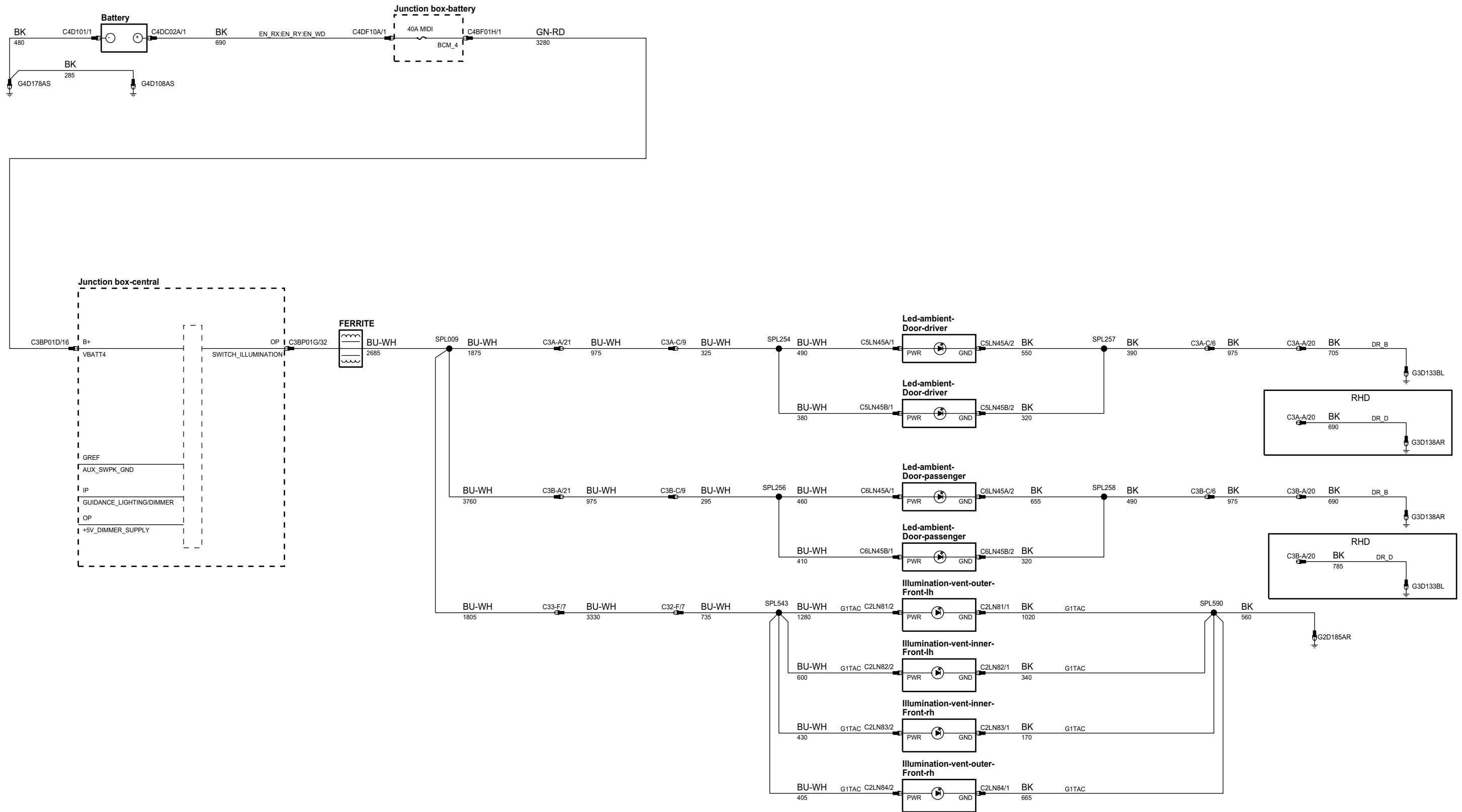

phcw93-70123-a-a3

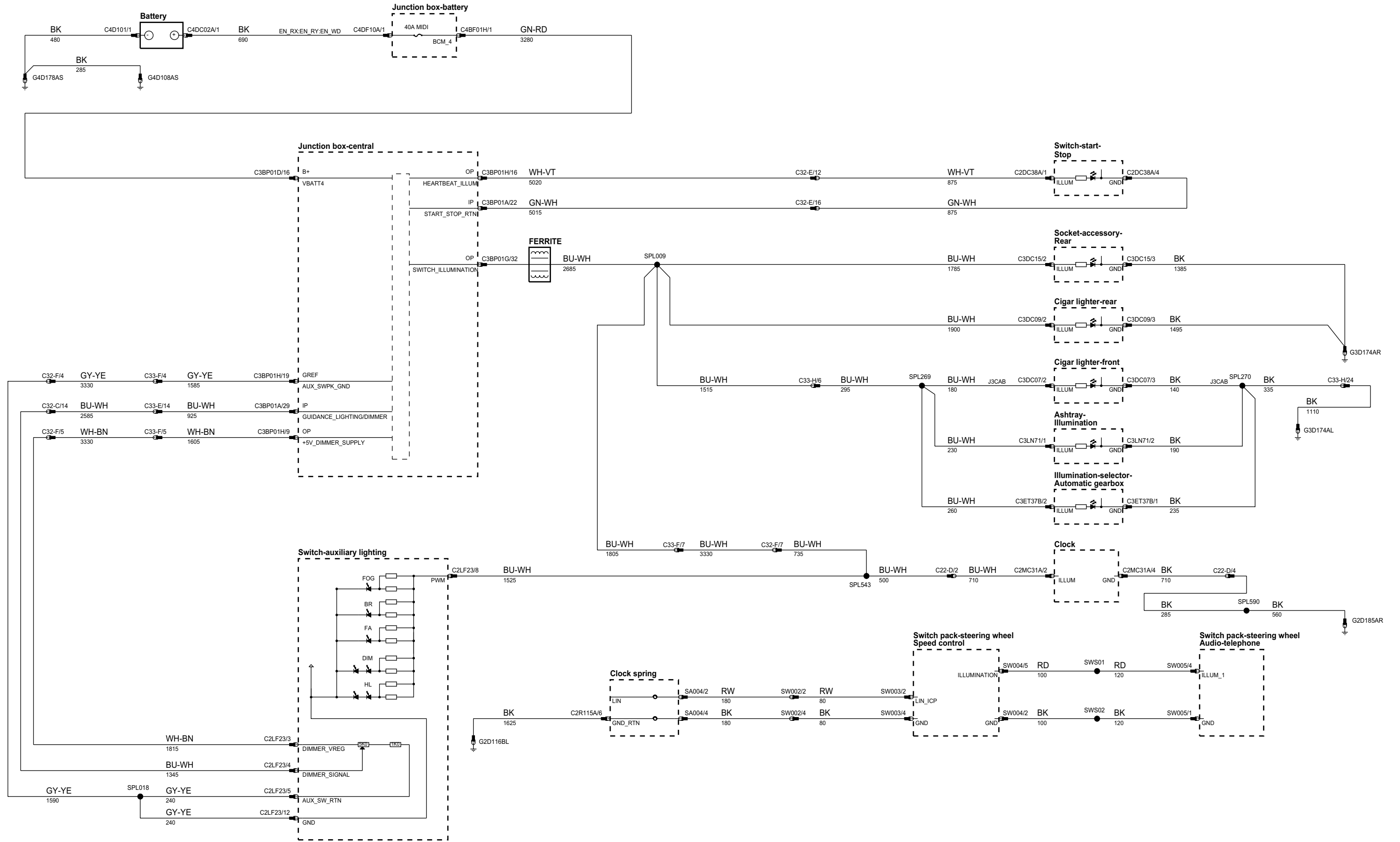

phcw93-70123-b-a3

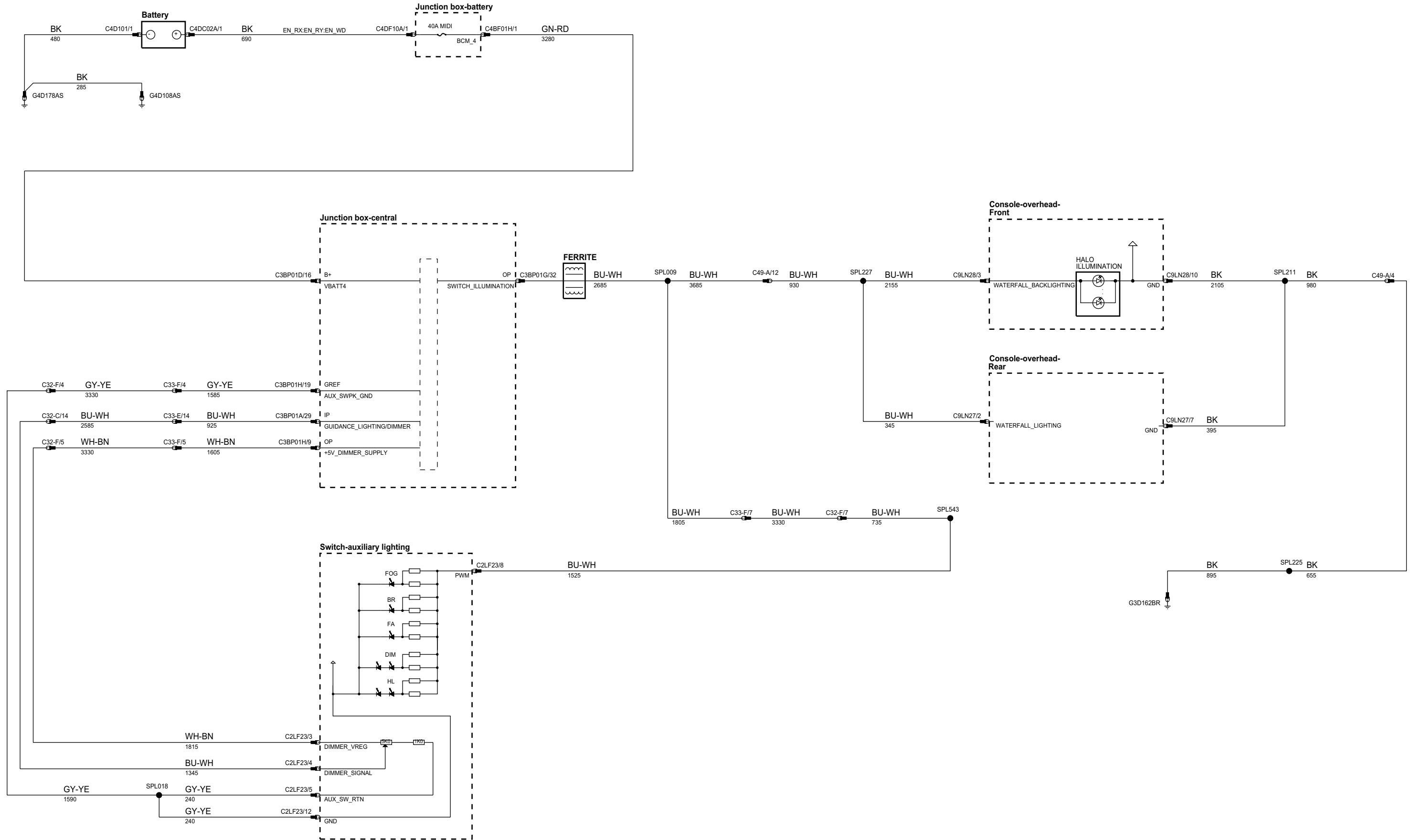

phcw93-70106-b-a3

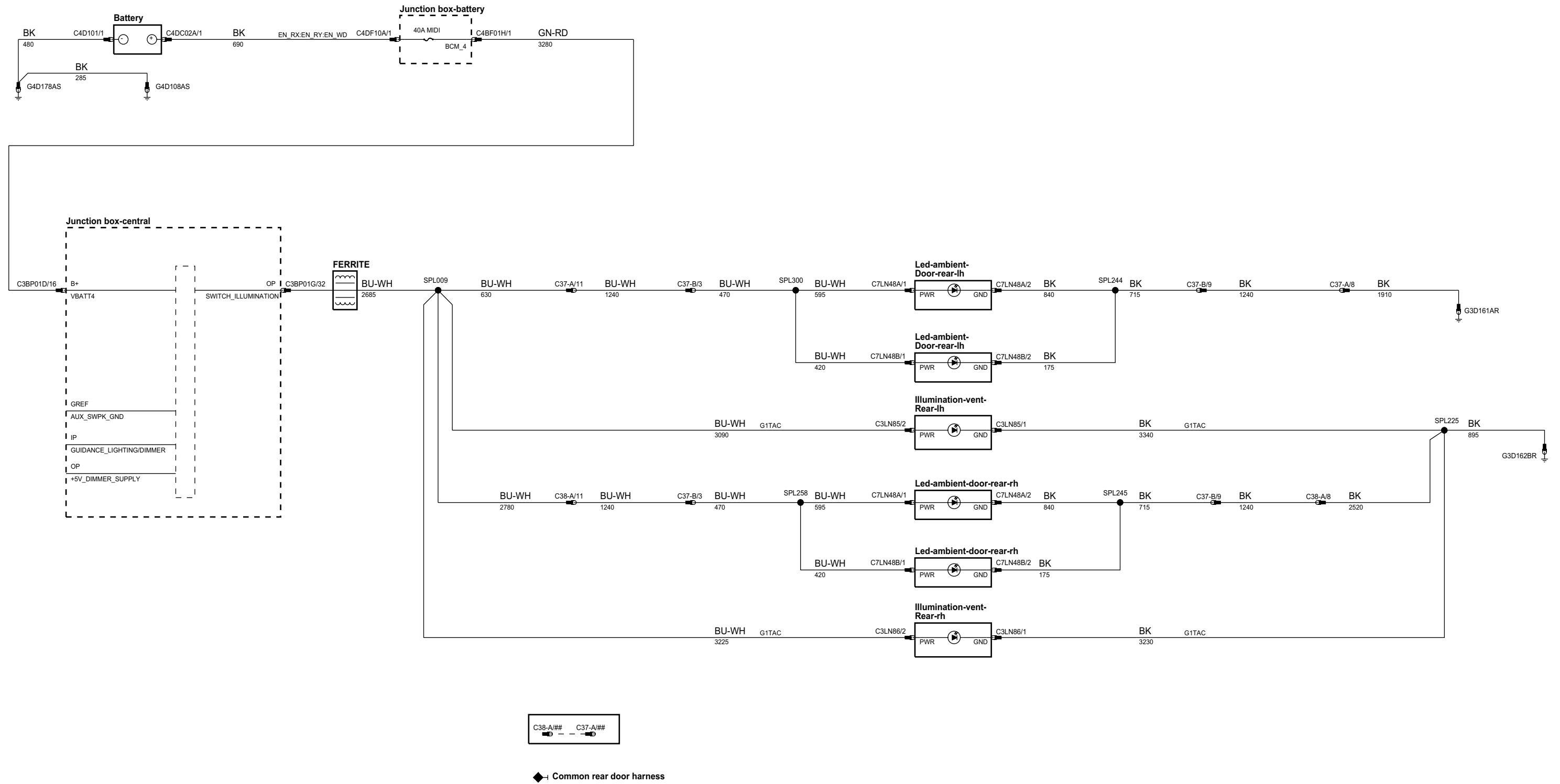

phow93-70016-a-a3

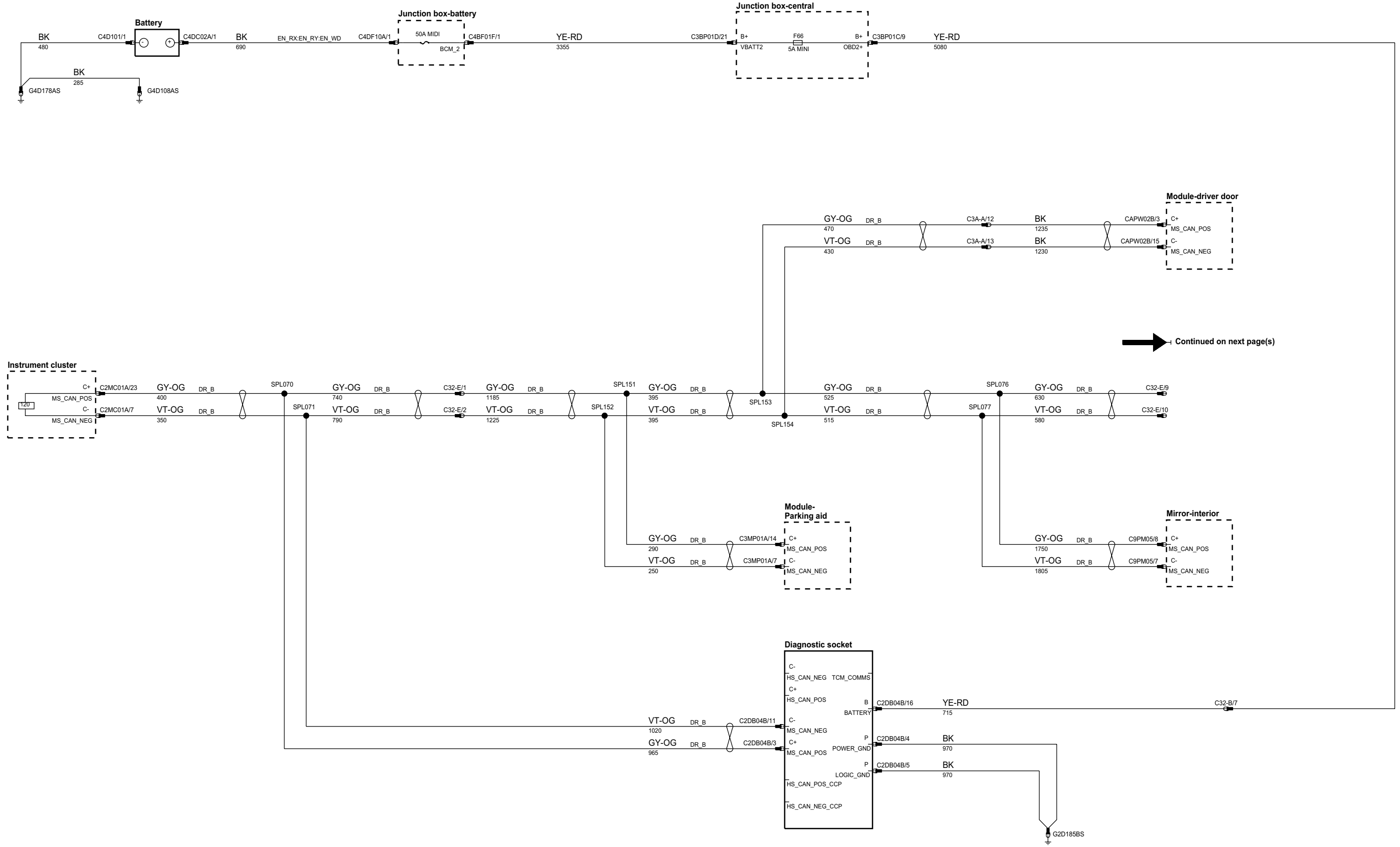

phcw93-70016-b-a3

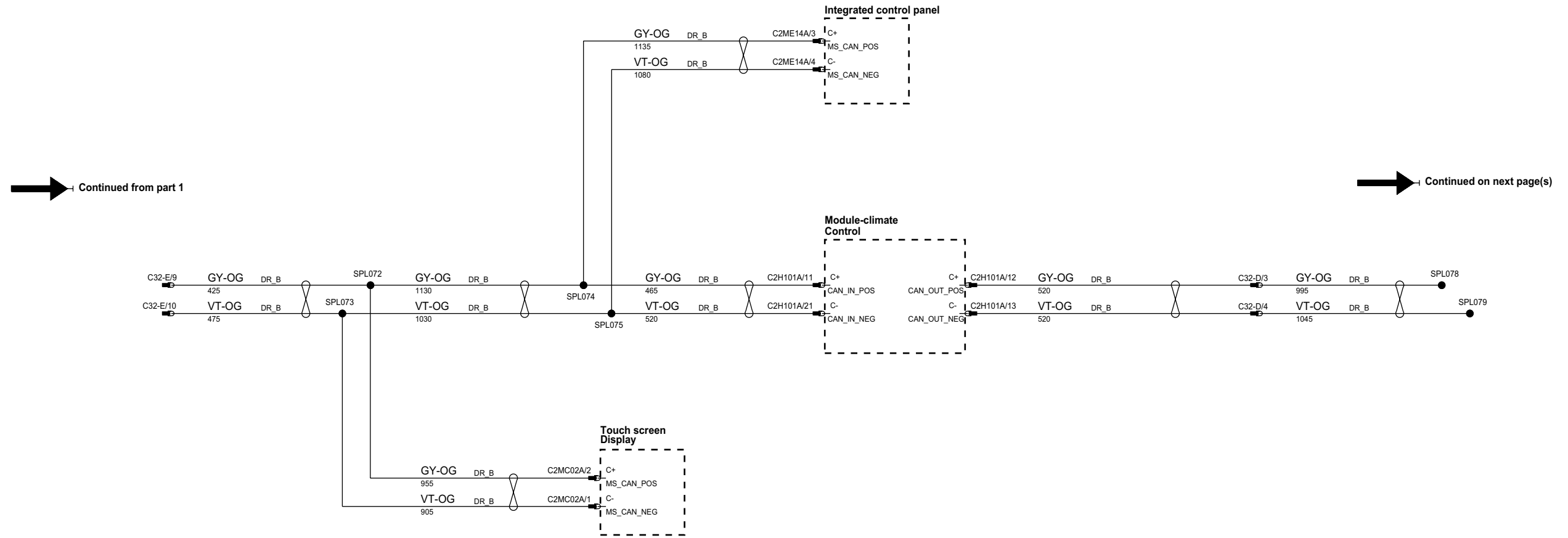

Continued from part 1

Continued on next page(s)

phcw93-70016-c-a3

Continued from previous page

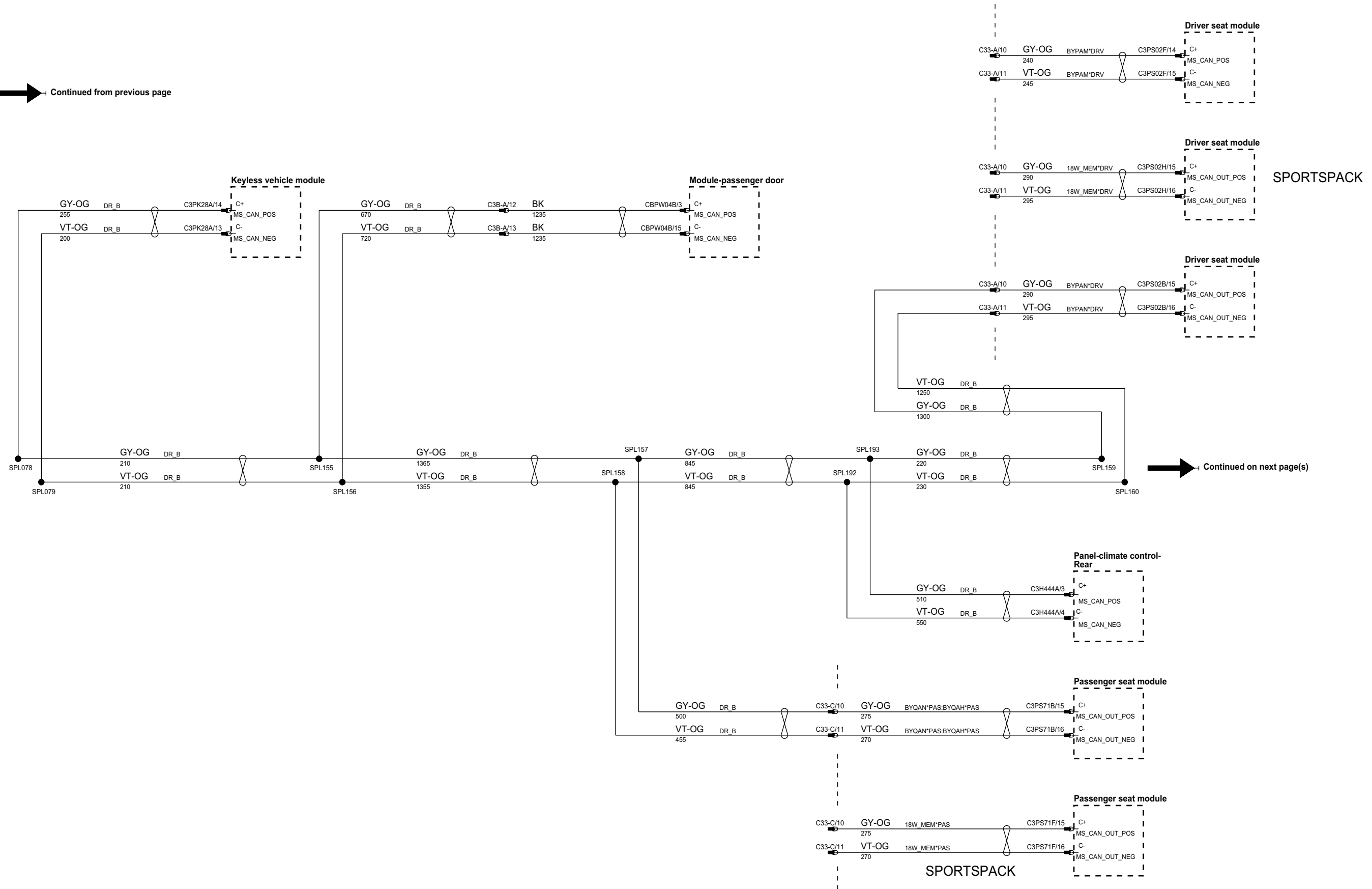

Continued on next page(s)

phcw93-70016-d-a3

Continued from previous page

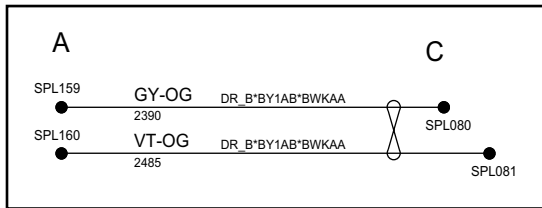
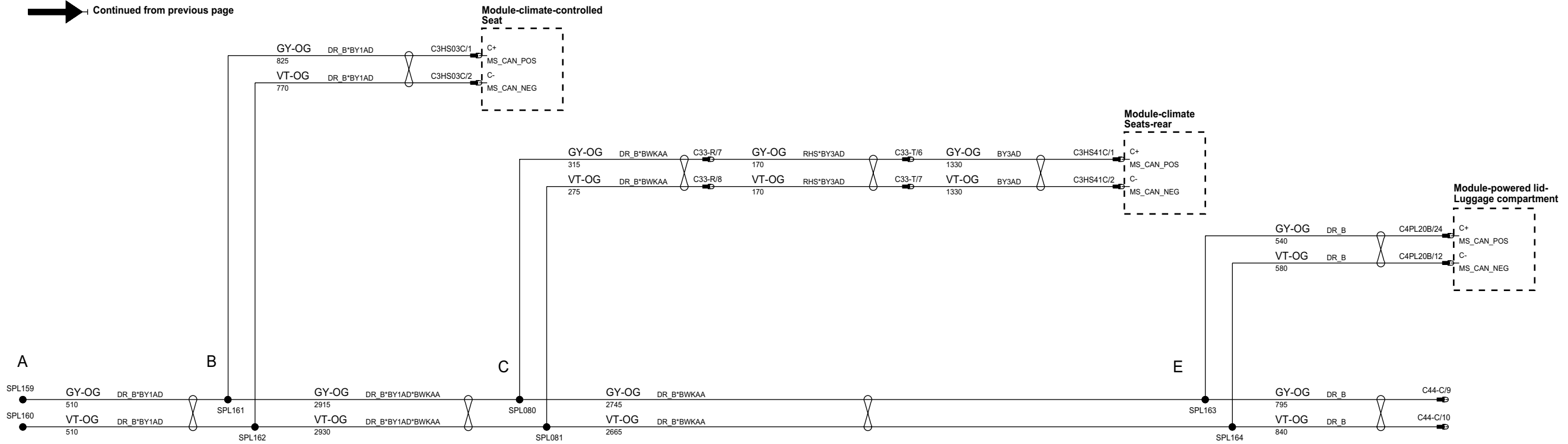

Continued on next page(s)

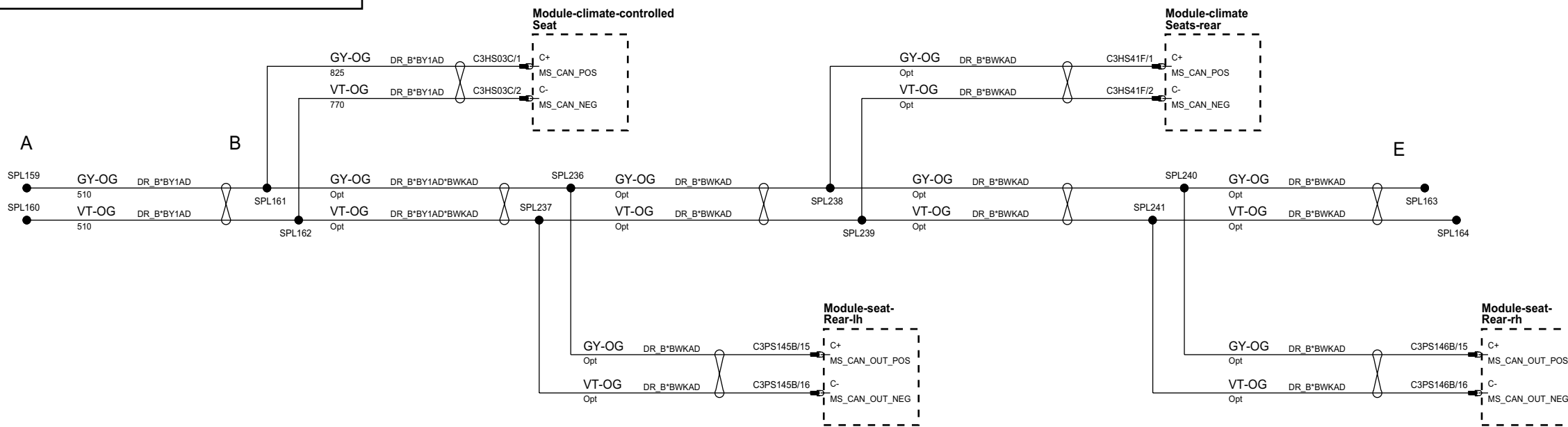

phcw93-70016-v-a3

Continued from previous page

