



ZF6HP19/26/32 (Generation 1), Ford 6R60, 6R75, 6R80, ZF6HP21/28/34 (Generation 2)

IDENTIFICATION GUIDE

Valve Body Identification

Valve components differ between **Generation 1** (ZF6HP19/26/32), **Ford 6R60, 6R75, 6R80** and **Generation 2** (ZF6HP21/28/34) valve bodies. Please use this identification guide to determine which generation you have to ensure correct valve kits and components are selected for your rebuild.

Generation 1 (ZF6HP19, 26 & 32), Ford 6R60, 6R75, 6R80

Generation 2 (ZF6HP21, 28 & 34)

1st Generation Case Side
Includes 19, 26 & 32

1. IDENTIFY!

2nd Generation Case Side
Includes 21, 28 & 34

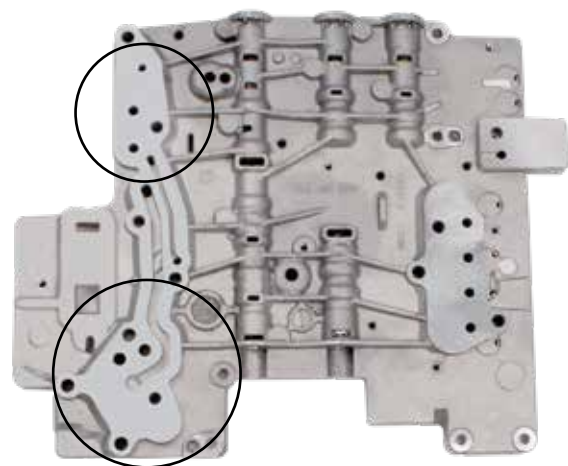
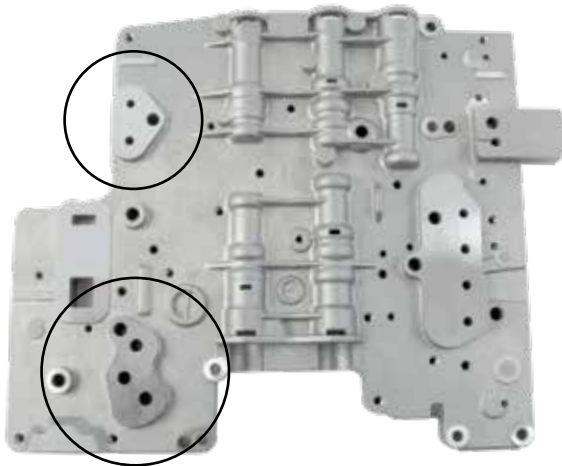

Different Sized Pressure Regulator
Valves and Sleeves

2. VERIFY!

Pressure Regulator Valves and Sleeves
Cannot Be Interchanged



Generation 1 (ZF6HP19, 26 & 32), with 053 Separator Plate



Verify OE dimensions indicated in order to select correct Sonnax parts.

NOTE: Some BMW 6 & 7 series with six accumulators have a different sized pressure regulator valve. This is most commonly seen on the A053/B053 separator plate applications.

CAUTION: Some valve sizes and locations differ from non-053 plate Generation 1 units. Reference 053 plate vacuum test guide and exploded view for details.



ZF6HP19, ZF6HP26, ZF6HP32 (Gen. 1), FORD 6R60, 6R75, 6R80 ZIP KIT

PART NUMBER ZF6-6R60-ZIP

QUICK GUIDE

Valve Body Identification

This Zip Kit **ZF6-6R60-ZIP** is designed for ZF6HP19, ZF6HP26, ZF6HP32 (Generation 1) units without an 053 separator plate, and Ford 6R60, 6R75, 6R80 applications only. A separate Zip Kit **ZF6-GEN2-ZIP** is available for ZF6HP21, ZF6HP28, ZF6HP34 (Generation 2), and **ZF6-053-ZIP** is available for ZF6HP19, ZF6HP26, ZF6HP32 (Generation 1) units with an 053 separator plate. See separate identification guide for details.

Parts are labeled here in order of installation. See other side of sheet for details on Zip Kit contents.

INSTALLATION DIAGRAM

Verify valve body is a Generation 1 model. See separate identification guide for details.

Upper Valve Body



NOTE: Some 6R60 and 6R80 units only have 2 accumulators.

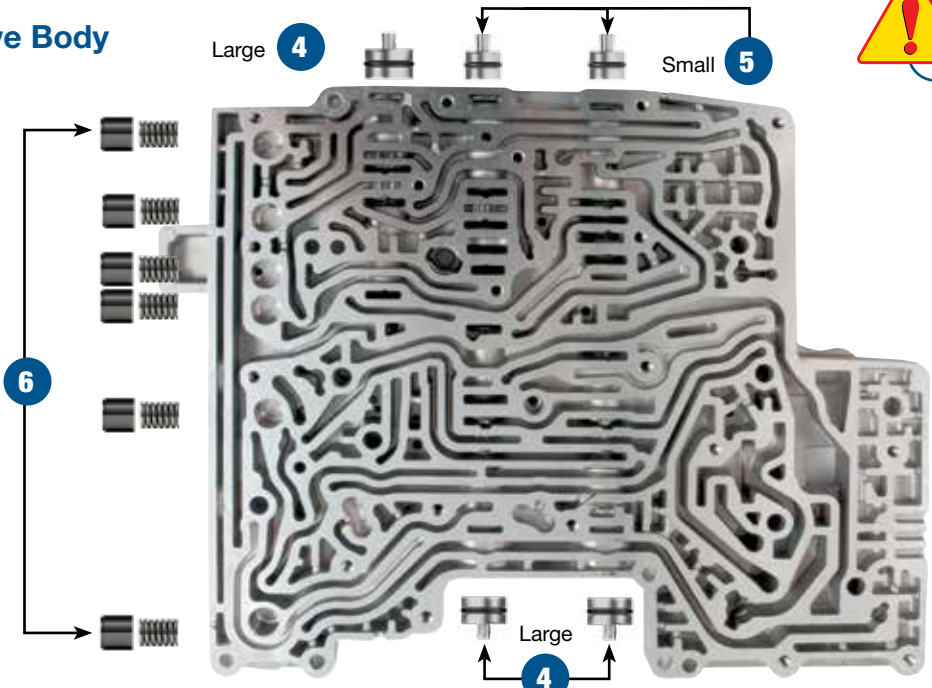

Lower Valve Body

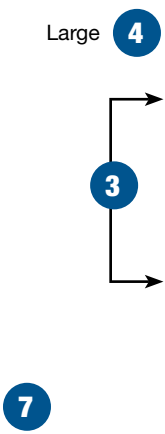

Solenoid O-Rings
Not Shown Here
See Page 3 of Booklet

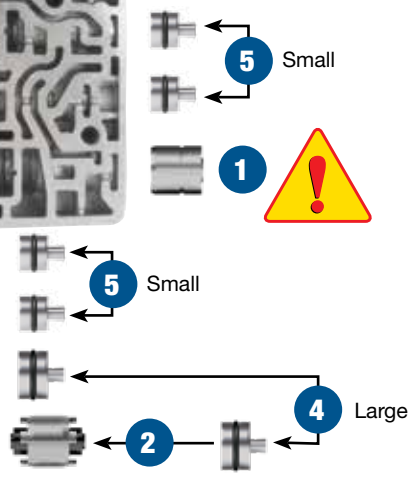

In addition to general rebuilding tips and technical information, the technical booklet included in this kit contains vacuum testing and additional repair options for higher mileage units or for repairing specific complaints which are beyond the scope of this kit.

Zip Kit Contents & Installation Steps

Step 1 Replace OE Sleeve



CAUTION: Verify OE pressure regulator valve and sleeve measurements. See separate Identification Guide for details.

Packaging Pocket 1

- Sleeve (.629" dia. x .645" length)

Step 2 Replace OE Sleeve & Valve

Packaging Pocket 2

- Valve
- Sleeve

Step 3 Replace Internal OE End Plugs

Packaging Pocket 3

- Internal End Plugs (4)
- O-Rings (11) 3 extra

Step 4 Replace Large OE End Plugs

Packaging Pocket 4

- End Plugs, Large (6)
- O-Rings, Large (9) 3 extra

Step 5 Replace Small OE End Plugs

Packaging Pocket 5

- End Plugs, Small (6)
- O-Rings, Small (9) 3 extra

Step 6 Replace OE Pistons

Packaging Pocket 6

- Accumulator Pistons (6)
- Matching Springs (6)



NOTE: Some 6R60 and 6R80 models only have 2 accumulators.

Step 7 Replace OE Solenoid O-Rings

Packaging Pocket 7

- O-Rings, Size 10.5 x 2mm thick, Smaller (8)
- O-Rings, Size 13 x 2mm thick, Larger (7)

Packaging Pocket 8

- O-Rings, Size 13.5 x 2mm thick (4)

Packaging Pocket 9

- O-Rings, Size 14.5 x 1.5mm thick (5)

Packaging Pocket 10

- O-Rings, Size 14.5 x 2mm thick (3)

Packaging Pocket 11

- O-Ring, OR-014, Smaller (2)
- O-Ring, OR-016, Larger (2)



NOTE: See page 3 in the technical booklet included with this Zip Kit for details on replacement solenoid O-ring locations.

Step 8 Vacuum Testing

Packaging Pocket 12

- Testing Spring
- Testing End Plug



NOTE: See page 4 in the technical booklet included with this Zip Kit for instructions on how to vacuum test valve body castings with these two parts.

NOTE: Solenoids should be vacuum tested to ensure internal sealing integrity that cannot be determined with resistance check.

NOTE: Solenoid test manifold kit **95430-VTK** is available separately, and requires the **VACTEST-01K** vacuum test stand kit. Visit www.sonnax.com for more details.

NOTE: The parts listed here may be protected by patent number 8,794,108.



ZF6HP19, ZF6HP26, ZF6HP32 (Gen. 1), FORD 6R60, 6R75, 6R80 ZIP KIT

PART NUMBER **ZF6-6R60-ZIP**

TECHNICAL BOOKLET

Valve Body Identification

This Zip Kit **ZF6-6R60-ZIP** is designed for ZF6HP19, ZF6HP26, ZF6HP32 (Generation 1) units without an 053 separator plate, and Ford 6R60, 6R75, 6R80 applications only.

A separate Zip Kit **ZF6-GEN2-ZIP** is available for ZF6HP21, ZF6HP28, ZF6HP34 (Generation 2), and **ZF6-053-ZIP** is available for ZF6HP19, ZF6HP26, ZF6HP32 (Generation 1) units with an 053 separator plate. See separate identification guide for details.

Torque Specifications

Mechatronic-to-Case or Valve Body Halves Bolts 8Nm/71 in-lb	Metal Oil Pan to Case 14Nm/10 ft-lb
Plastic Oil Pan to Case 10Nm/89 in-lb	Pump Bolts to Case 10Nm/89 in-lb
Output Shaft Flange Nut 60Nm/44 ft-lb	

Clearance & Endplay

Rear Unit Endplay (flanged output) 0.15-0.35mm/.006-.013"	Input Shaft Endplay 0.2-0.4mm/.008-.015"
--	--

Clutch clearance and material is critical (refer to OE clutch travel specifications). These have fluid balanced clutch pistons.

Fluid

Ford 6R60 extension housing has an allen head fill plug and/or the front corner of the case has a hex head fill plug. A dipstick lives within this plug.

Note: *The thermal element must open (88°C, 190°F) to purge the cooler before verifying the fluid level!*

Complete Fill Required 9.5 qt./9 ltr.	Service Fill Approx. 4.2 qt./4 ltr.
Ford Fluid XT-6-QSP, Mercon SP	ZF Fluid S671 090 0255- Shell M-1375.4

Drive-Cycle Relearn

Ford requires six light throttle up and coastdown shift cycles (after obtaining 80°C/175°F) for a partial relearn.

Cautions

Electronics

Do not use an ohm meter with more than .6 voltage supply. The TCM is capable of limited solenoid adaptation without reprogramming. After any service, resetting adapts/clearing KAM is suggested. In many instances, solenoids can be replaced with new OE or with qualified used. Original solenoids, if reused, should be returned to their same location due to a learned flow rate by the TCM. Make every effort to avoid mixing up the solenoids.

It is not advised to attempt circuit testing through the 16-pin connector. Check the solenoid resistance (5.0 ohms at 20°C/68°F) with the circuit board removed.

Visual Identification

The ZF6 has two generations:

- 2002–2005 ZF6HP19, ZF6HP26, ZF6HP32 = Generation 1
- 2006-later ZF6HP21, ZF6HP28, ZF6HP34 = Generation 2

The 19, 26 and 32 of Generation 1 ZF6 units refer to the sequentially larger amounts of torque capacity. In 2006, the mechatronic was upgraded to increase oil flow, which reduced the duration of the shift. These units became known as Generation 2, and were given the numbers 21, 28 and 34. The photos on the separate identification guide show how to identify and verify the valve body as a Generation 1 or Generation 2 version with the updated solenoids.

Within both vintages, there is an “M” version for the manual valve and an “E” solenoid controlled manual valve. The “E” version in both the early and late generations will have two additional solenoids, for a total of 9.

Technical Tips

2-1 Clunk (6R60 & 6R80 Only)

Ford 6R60 and 6R80 units commonly display a 2-1 down shift clunk. In mid-2010, a manufacturing change was made eliminating this clunk on models produced after mid-2010. However, in mid-2010 and earlier models, there is NO known OE or aftermarket remedy.

Reprogramming

As indicated on the photo (**Figure 1**) an engraved number identifies this mechatronic as a service unit. This exchange unit may also have a blue paint dot, (**Figure 2**) on the solenoid end of the plastic frame, next to the bar code part number. This blue dot indicates it is NOT programmed and that the unit must be flashed with vehicle application prior to installation.

A white dot in the same area indicates the unit HAS been programmed without the transmission.

A pin dot identification in the same area with a fifth, sixth or seventh digit of 128 indicates this is a NEW unit, not a serviced mechatronic.

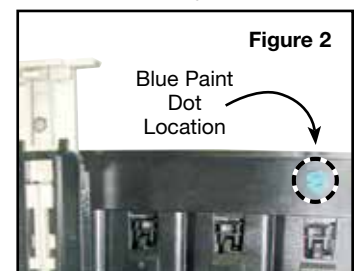
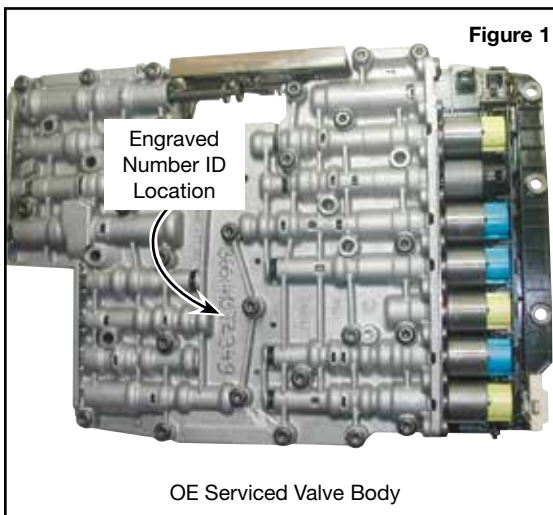

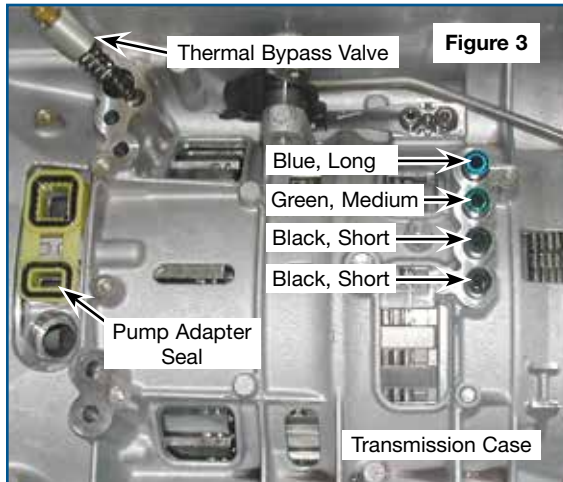

Technical Tips (continued)

Transmission Specifications & Reassembly Tips

ZF suggests the body-to-case, pump in/out adapter seal be replaced on every valve body R-R (Figure 3). The overall seal height on these vary depending on application. Make sure you have the correct size.

There are four mechatronic-to-case center support seals. The longest (blue) resides next to the manual linkage, medium (green) next to it. The two shortest ones (black) are furthest from the linkage (Figure 3).

The Ford 6R60 thermal bypass valve lives in the front corner, between case and valve body. The spring installs into the case, followed by the thermal valve – small tip end up.

Zip Kit Instructions

1. Valve Body Removal from Case

- Press release tab and lift connector retainer (Figure 4).
- Pull connector sleeve out of case.
- Remove 10 or 11 bolts to drop valve body from case (Figure 5).

2. Valve Body Disassembly

- Remove seven bolts to remove TCM from valve body (Figure 6).
- Remove TCM (Figure 7).
- Pry valve body halves from separator plate where indicated (Figure 8).

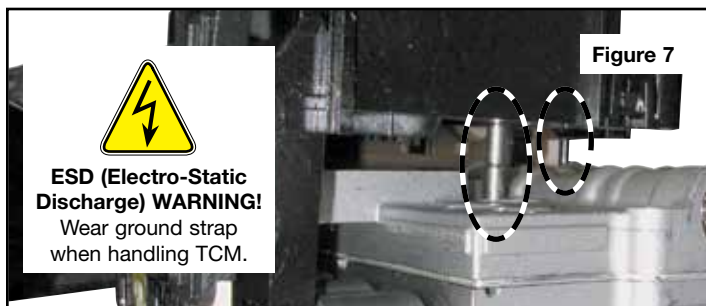
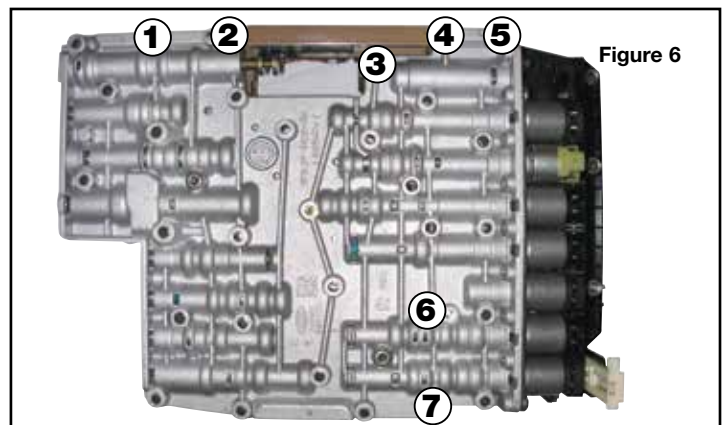
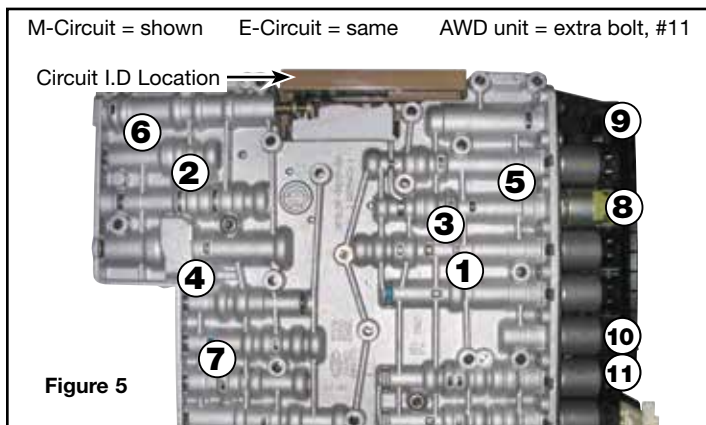
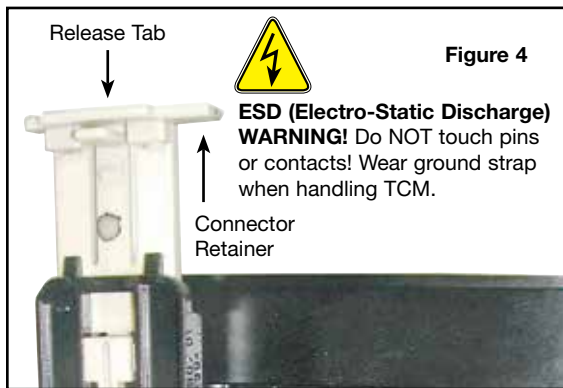

2. Valve Body Disassembly (continued)

NOTES: The separator plate has a bonded gasket which may delaminate during disassembly (**Figure 9**). If any damage or delamination to the gasket is present, a new Sonnax separator plate should be used.

These separator plates are specifically calibrated, requiring either the OE valve body code or an identification number stamped on original plate (**Figures 10 & 11**) for reorder. See Sonnax application chart for cross-reference numbers (**Figure 12**).

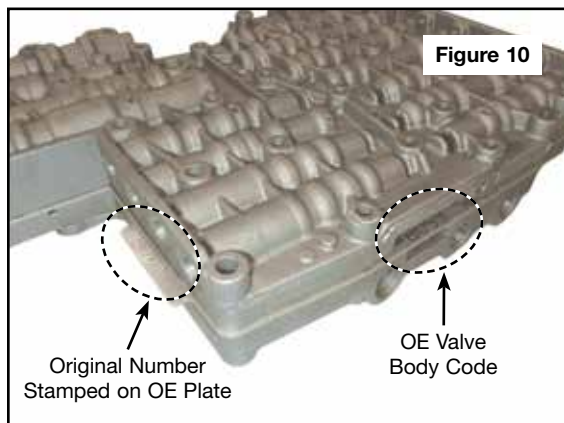
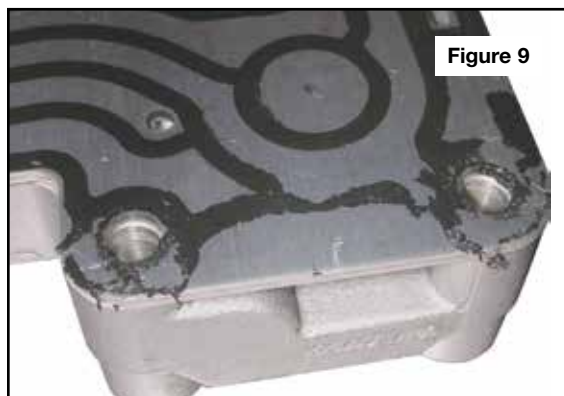
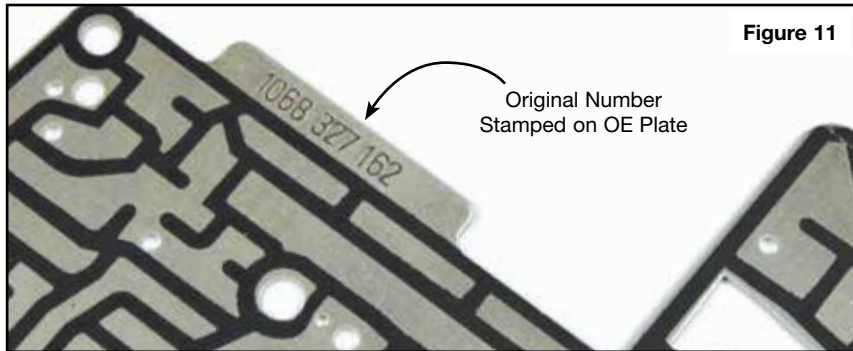

Valve Body Separator Plate Application Chart Figure 12

OE Valve Body Code	Number Stamped on Original Plate	Order Sonnax Part Number	Valve Body Generation
E510F	6L2P-7Z490-FC or 6L2P-7Z490-FB	95740-510**	Ford 6R60
A035/B035	1068-327-141	95740-035	ZF6HP19/26/32 (Generation 1)
A036/B036	1068-327-145	95740-051*	
A046/B046	1068-327-162	95740-046	
A047/B047	1068-327-163	95740-047	
A051/B051	1068-327-179	95740-051*	
A052/B052	1068-327-180	95740-052	
A053/B053	1068-327-189	95740-053	ZF6HP21/28/34 (Generation 2)
A063/B063	1068-327-210	95740-063	
A065/B065	1068-327-224	95740-065	

*Sonnax valve body plate **95740-051** is a direct replacement for both OE valve body codes A036/B036 and A051/B051, due to supersession by ZF.

Sonnax valve body plate **95740-510 is a replacement for OE plates stamped with part number 6L2P-7Z490-FB or 6L2P-7Z490-FC.

3. Installation

Install Zip Kit parts as shown on diagram of separate quick guide sheet included in this Zip Kit. The locations of the replacement solenoid O-rings are shown at left (**Figure 13**). For additional solenoid information see Solenoid O-Ring Sizes charts and Solenoid Function charts (**Figures 14–17**) on page 8 of this booklet.

Sonnax recommends vacuum testing critical wear areas not covered by this kit to determine whether additional Sonnax parts are required (see pages 4–5).

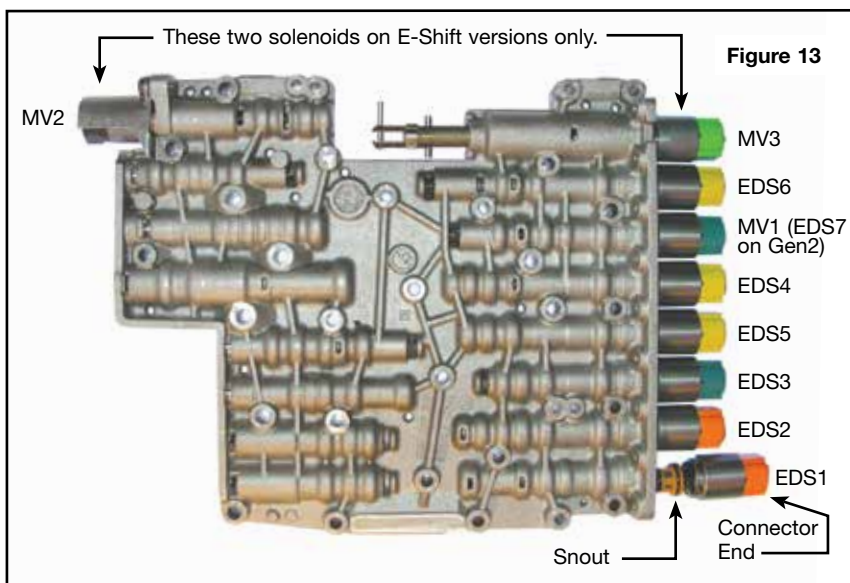

NOTE: O-ring sizes vary depending upon solenoid, location, make, model and generation version. Included in this Zip Kit are 31 standard replacement-size O-rings for the various solenoids. It is recommended to verify the size of the replacement O-ring by physically comparing it against the OE. The chart (**Figure 14**, page 8) provides some general guidance.

Critical Wear Areas & Vacuum Test Locations

NOTE: OE valves are shown in rest position and should be tested in rest position unless otherwise indicated. Test locations are pointed to with an arrow. Springs are not shown for visual clarity. Low vacuum reading indicates wear and Sonnax parts noted for replacement.

Lower Valve Body • Jaguar ZF6HP26, M-Shift Shown

Solenoid Pressure Regulator Valve

- Flare/Harsh shifts • Wrong gear starts TCC slip
- Harsh upshifts/downshifts • Delayed Forward/Reverse
- Solenoid performance codes • Gear ratio codes

Replace with **Sonnax Part No. 95740-17K**
Requires F-95740-TL17 & VB-FIX

Test 2: Test this port with valve in regulating position. Block valve inboard with enclosed testing spring.

Use Testing Spring

End Plugs

- Inconsistent shift quality
- Replace with **Sonnax Part No. 95740-25K***

Vacuum test these plugs at the retainer slot. This checks both diameters of the plug.



There are numerous OE circuit/worm-track configurations. They are make, model, generation and E- vs. M-Shift dependent. Use the illustrated port locations as a guide for identifying specific valve spools to vacuum test on alternate circuit configurations.

Clutch A Control Pressure Regulator Valve

- Downshift bind-ups • 4-5 Shift concerns
- Flare shifts • Delayed/Harsh Forward
- Excess clutch overlap & clutch distress
- Pressure control out-of-range codes

Replace with **Sonnax Part Nos.**
95740-09K Oversized Clutch A Control Valve Kit
95740-21K* Clutch A Control Boost Valve Kit
95740-09K: Requires F-95740-TL8 & VB-FIX

Test 1: In Rest

Clutch E Control Pressure Regulator Valve**

- Excess clutch overlap & clutch distress
- Pressure control out-of-range codes • 3-2 Harsh
- Downshift bind-ups • 1-2 Bind-up • Coastdown Neutral

Replace with **Sonnax Part No.**
95740-08K** Requires F-95740-TL8 & VB-FIX

Ensure that valve spool is centered in location to test.

Bypass Clutch Control Regulator Valve

- TCC codes • Excess TCC slip • Cycling RPM
- Flare/Harsh shifts • Low TCC release pressure
- Rough idle in Reverse • Overheated converter

Replace with **Sonnax Part No.**
95740-13K Requires F-95740-TL13 & VB-FIX

Main Pressure Regulator Valve**

- Poor shift quality • Flare/Harsh shifts
- Erratic line pressure • Delayed/No Reverse

Replace with **Sonnax Part Nos.**
95740-01K OR **95740-78K** Oversized PR Valve Kits
95740-03* OR **95740-79*** Pressure Regulator Sleeves
95740-01K Requires F-95740-TL & VB-FIX
95740-78K Requires F-95740-TL78 & VB-FIX

Test 1: In Rest

Test 2: Test this port with valve in inverted position. Hold valve and spring in place with enclosed testing end plug.

Use Test End Plug

**NOTE: ZF6HP19/26/32 (Gen. 1) applications with an 053 separator plate have significantly different valve lineups and locations. Reference [Vacuum Test Guide for 053 plate](#) for test locations and replacement parts.



For specific vacuum test information, refer to individual part instructions included in kits and available at www.sonnax.com.

Upper Valve Body • Jaguar ZF6HP26, M-Shift Shown

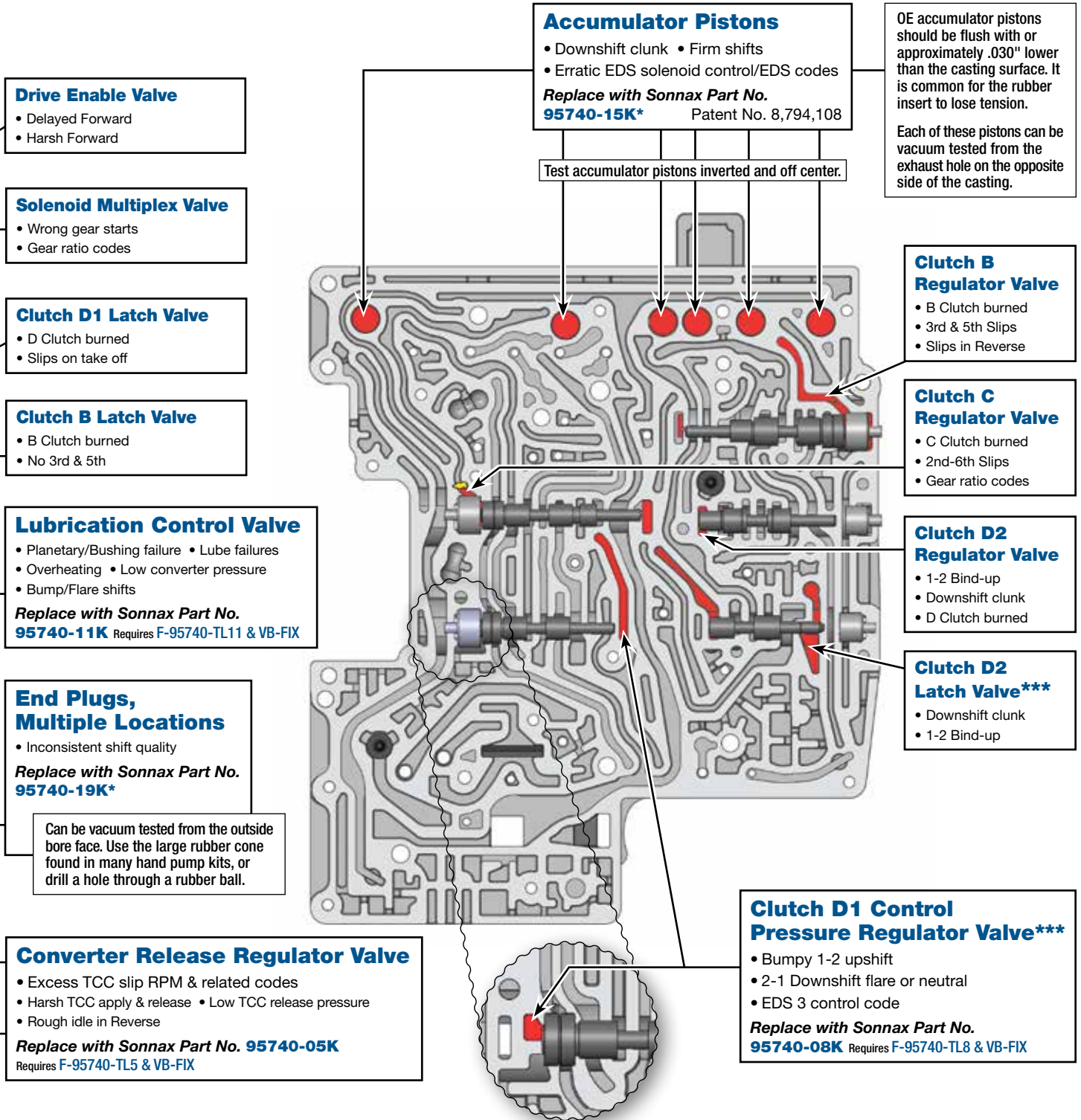

Part numbers with an asterisk () are included in this Zip Kit. Other part numbers are available separately.

***6R80 applications, 2012-later, have a different design clutch D1 pressure regulator valve. Sonnax part 95740-08K will not work in that application. A quick identification of this valve body is lack of clutch D2 latch valve.

OE Exploded View

Lower Valve Body • Jaguar ZF6HP26, M-Shift Shown Here

NOTE: Depending upon vehicle application, the OE springs shown may not be present.

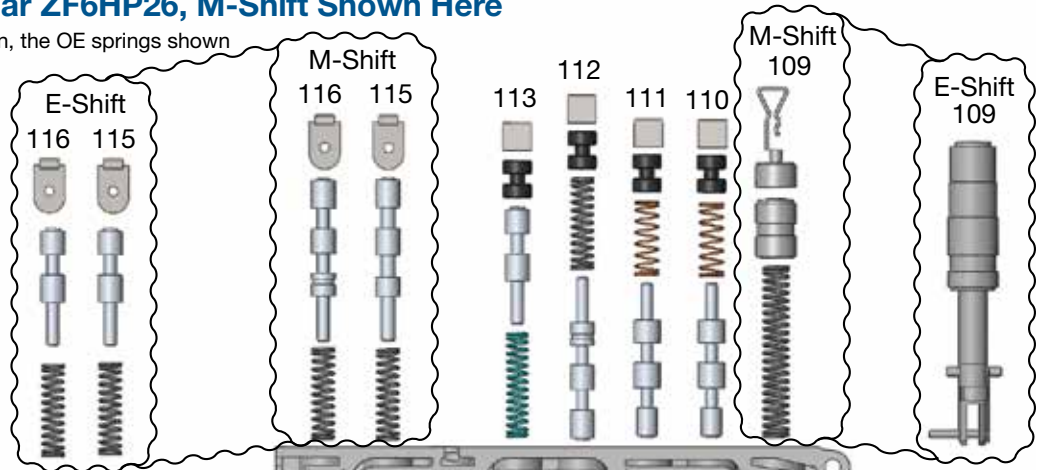

Lower Valve Body Descriptions	
I.D No.	Description
101	Manual Valve (M-Shift)
	Parking Lock Valve (E-Shift)
102	Lubrication Control Valve
103	Converter Release Regulator Valve
104	Main Pressure Regulator Valve
105	Bypass Clutch Control Regulator Valve
106	Clutch E Latch Valve
107**	Clutch E Control Pressure Regulator Valve
108	Clutch A Control Pressure Regulator Valve
109	Delay Accumulator Piston (M-Shift)
	Park Lock Cylinder (E-Shift)
110	Solenoid Multiplex Valve
111	Drive Enable Valve
112	Clutch D1 Latch Valve
113	Solenoid Pressure Regulator Valve
115	Clutch B Latch Valve (M-Shift)
	Clutch B Latch Valve (E-Shift)
116	Clutch A Latch Valve (M-Shift)
	Clutch A Latch Valve (E-Shift)

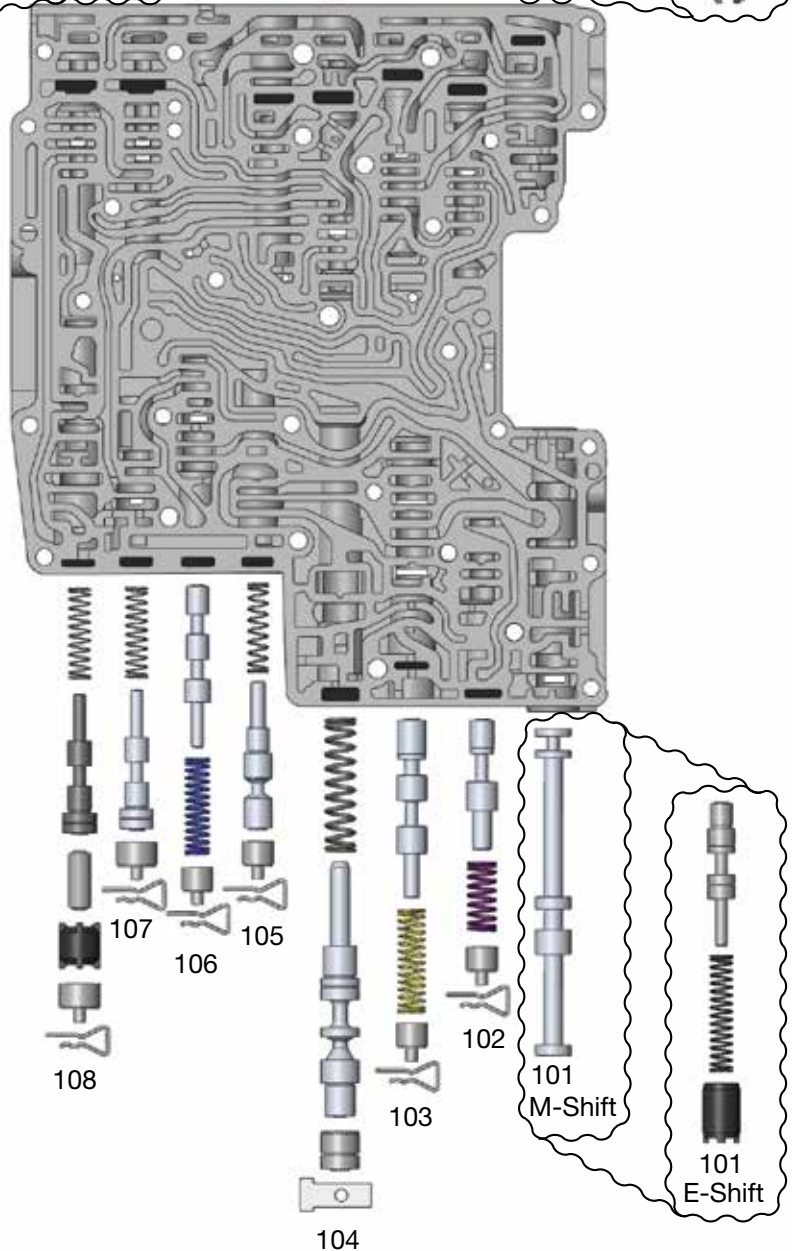

****NOTE:** ZF6HP19/26/32 (Gen. 1) applications with an 053 separator plate have significantly different valve line-ups and locations. Reference [Vacuum Test Guide for 053 plate](#) for test locations and replacement parts.

Upper Valve Body • Jaguar ZF6HP26, M-Shift Shown Here

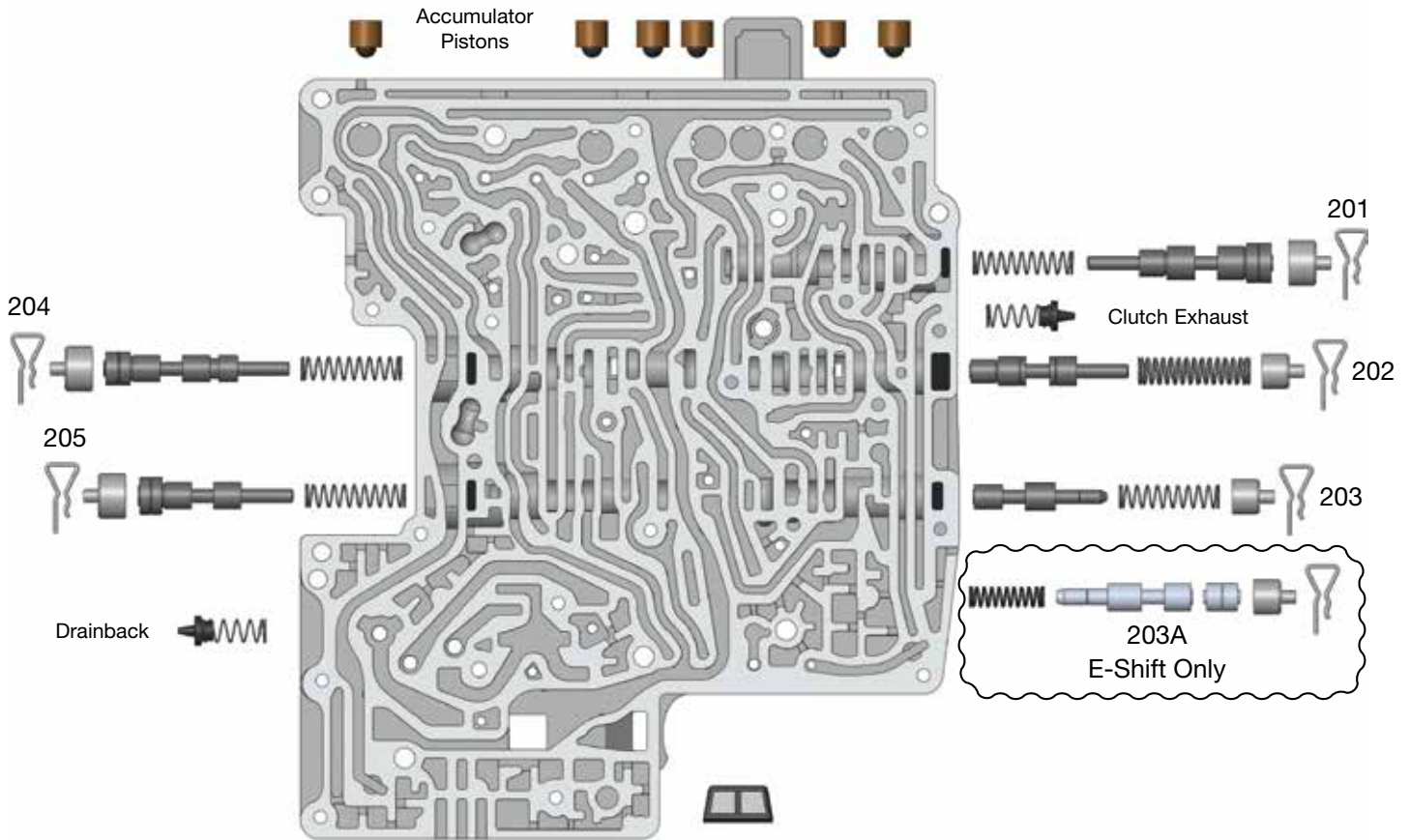

Upper Valve Body Descriptions

I.D. No.	Description
201	Clutch B Regulator Valve
202	Clutch D2 Regulator Valve
203	Clutch D2 Latch Valve
203A	Position D Valve
204	Clutch C Regulator Valve
205	Clutch D1 Control Pressure Regulator Valve

Technical Tips (continued from page 3)

ZF Solenoid O-Ring Sizes Figure 14			
Connector Color	Snout Color	Inboard O-Ring Size	Outboard O-Ring Size
Yellow / Green**	Black	10.5 x 2mm	13.5 x 2mm
Blue / Black / Gray**	Yellow	10.5 x 2mm	13 x 2mm
Orange	Orange	10.5 x 2mm	14.5 x 2mm
Black (Typical MV1 solenoid in Gen 1 & MV2 solenoid on E-Shifts)	Short Black	14.5 x 1.5mm	14.5 x 1.5mm



NOTE: Solenoid connector colors can fade with high mileage and high temperature. Example: blue can look like green and yellow can look like tan.

ZF Solenoid Function Figure 15				
Connector Color	Location	Output	Resistance at 68°F (20°C)	Function
Generation 1: ZF6HP19, ZF6HP26, ZF6HP32				
Yellow / Green**	EDS 1, 3, 6	0 psi (0 bar) at 0 mA	5.05 ohms	1 – A Clutch; 3 – C Brake; 6 – TCC
Blue / Black / Gray**	EDS 2, 4, 5	67 psi (4.6 bar) at 0 mA	5.05 ohms	2 – B Clutch; 4 – D & E Clutch; 5 – EPC
Black	MV1	Open/Closed	11.5 ohms	Selector Valve
Black	MV2	Open/Closed	11.5 ohms	Park Lock Valve
Green	MV3	Open/Closed	11.5 ohms	Park Lock Cylinder
Generation 2: ZF6HP21, ZF6HP28, ZF6HP34				
Orange	EDS 1, 2	0 psi @ 0mA	5.05 ohms	1 – A Clutch; 2 – TCC
Yellow	EDS 4, 5, 6	0 psi @ 0 mA	5.05 ohms	4 – E Clutch; 5 – C Clutch; 6 – D1 & D2 Brake
Blue	EDS 3, 7	67 psi @ 0mA	5.05 ohms	3 – B Clutch; 7 – EPC
Black	MV2	Open/Closed	11.5 ohms	Park Lock Valve
Green	MV3	Open/Closed	11.5 ohms	Park Lock Cylinder

** = Found on some Audi applications

Ford Solenoid O-Ring Sizes Figure 16			
Connector Color	Snout Color	Inboard O-Ring Size	Outboard O-Ring Size
Ford 2007–2009: 6R60			
Brown	Long Black	10.5 x 2mm	13.5 x 2mm
Black	Long Black	10.5 x 2mm	13 x 2mm
Cream	White	OR-014	OR-016
Ford 2010–Later: 6R60			
Tan	Brown	10.5 x 2mm	13.5 x 2mm
Tan	Black	10.5 x 2mm	13 x 2mm
Tan (2010–2011)	White	OR-014	OR-016
Tan (2012–Later)	Gray	OR-014	OR-016



TECH TIP: Solenoids in these units (especially the more active solenoids) commonly malfunction, leading to hydraulic control trouble, requiring solenoid replacement in many cases.

Ford Solenoid Function Figure 17				
Connector or Snout Color	Location	Output	Resistance at 68°F (20°C)	Function
Ford 2007–2009: 6R60				
Brown	SSA, SSC, TCC, VFS1, VFS3, VFS6	0 psi (0 bar) at 0 mA	5.05 ohms	1 – A Clutch; 3 – C Brake; 6 – TCC
Black	SSB, SSD, PCA, VFS2, VFS4, VFS5	67 psi (4.6 bar) at 0 mA	5.05 ohms	2 – B Clutch; 4 – D & E Clutch; 5 – EPC
Cream	SSE/SS1	Open/Closed	11.5 ohms	Solenoid Multiplex/Drive Enable Valve
Ford 2010 – Later: 6R60/6R80				
Brown	SSA, SSC, TCC, VFS1, CFS3, VFS6	0 psi @ 0 mA	5.05 ohms	1 – A Clutch; 3 – C Brake; 6 – TCC
Black	SSB, SSD, PCA, VFS2, VFS4, VFS5	67 psi (4.6 bar) at 0 mA	5.05 ohms	2 – B Clutch; 4 – D & E Clutch; 5 – EPC
Cream (2010–2011)	SSE/SS1	Open/Closed	11.5 ohms	Solenoid Multiplex/Drive Enable Valve
Gray (2012–Later)	SSE/SS1	Open/Closed	18 ohms	Solenoid Multiplex/Drive Enable Valve