

SUPERCHARGER COOLING - V8 S/C 5.0L PETROL

# SUPERCHARGER COOLING - SYSTEM OPERATION AND COMPONENT DESCRIPTION

(G1088332)

DESCRIPTION AND OPERATION

CONTROL DIAGRAM

△ NOTE:

A = Hardwired

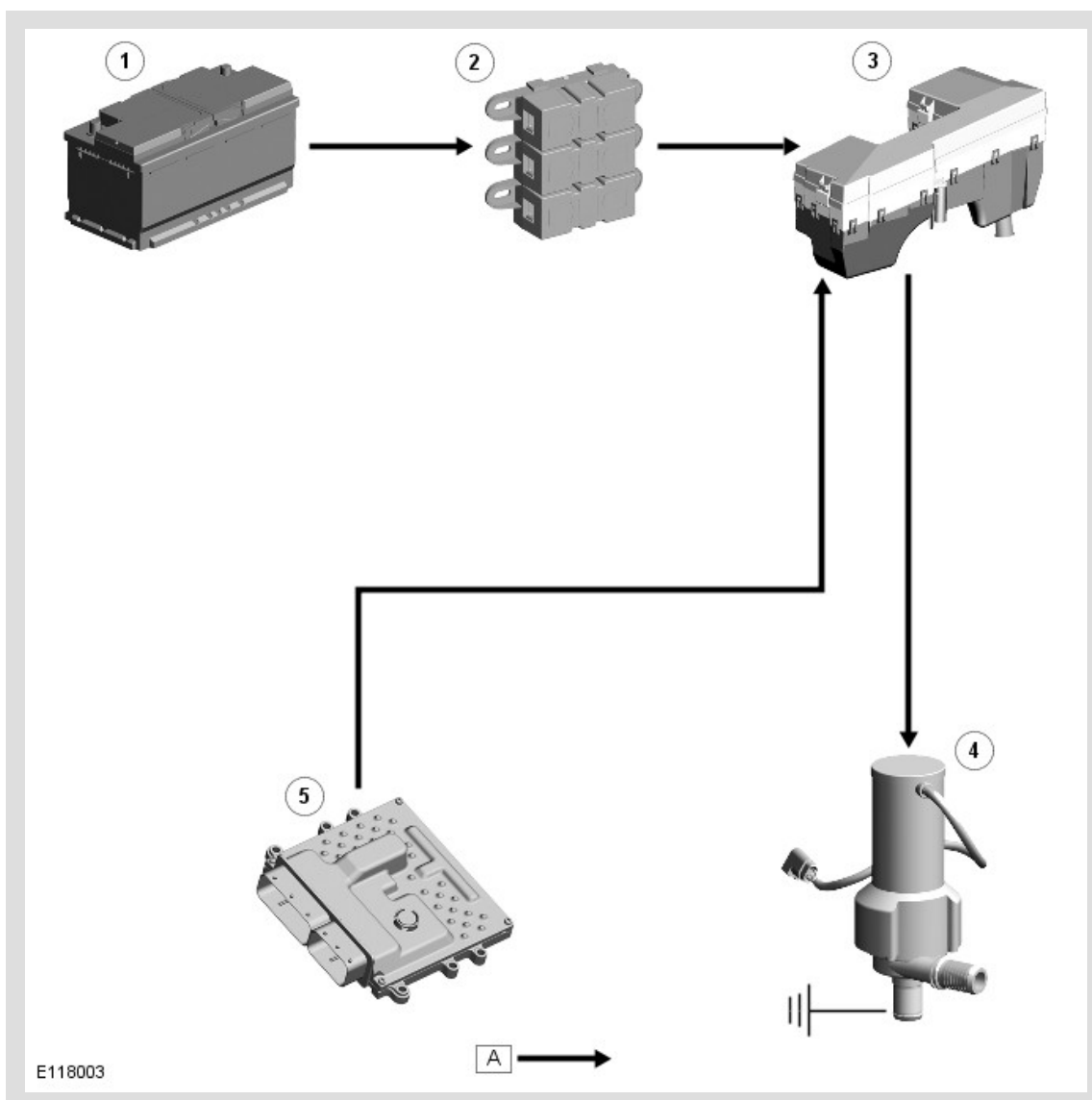

ITEM	DESCRIPTION
1	Battery
2	BJB (battery junction box) (250 A megafuse)
3	EJB (engine junction box)
4	Charge air coolant pump
5	ECM (engine control module)

## Supercharger Cooling Flow Diagram

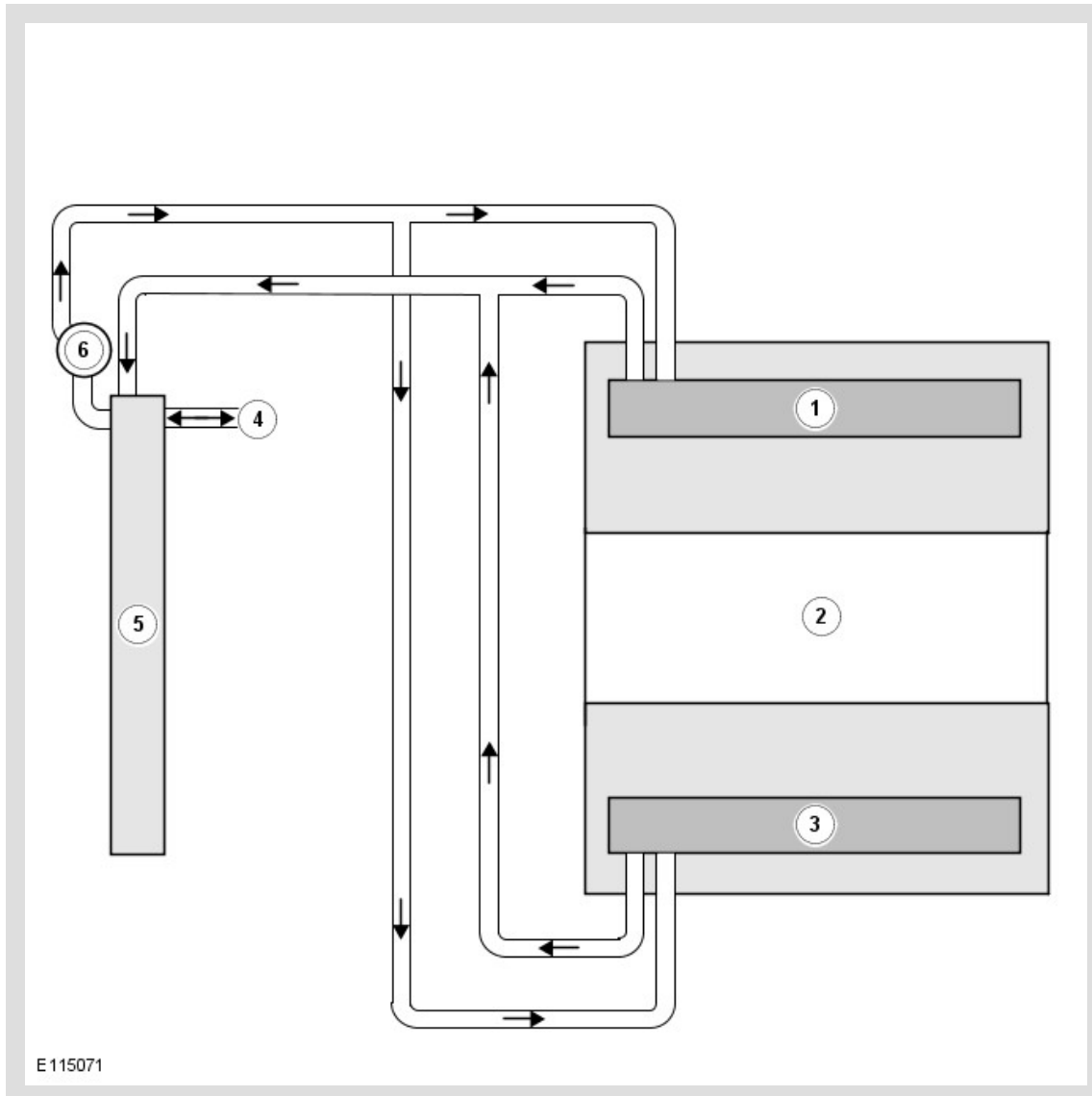

ITEM	DESCRIPTION
1	RH (right hand) charge air cooler
2	Engine
3	LH (left hand) charge air cooler
4	Expansion hose connection (with engine cooling system)
5	Charge air radiator
6	Charge air coolant pump

Electrical power for the charge air coolant pump is supplied from the intercooler water pump relay in the power distribution box. When the intercooler water pump relay is energized, it connects power from the battery, via the BJB (battery junction box) and CJB (central junction box) , to the charge air coolant pump. Operation of the intercooler water pump relay is controlled by the ECM (engine control module) . The intercooler water pump relay is energized continuously while the ignition is in power mode 6.

When the charge air coolant pump is running, coolant flows from the pump outlet through the charge air coolers, the charge air radiator and back to the pump inlet.

## COMPONENT DESCRIPTION

## CHARGE AIR COOLANT PUMP

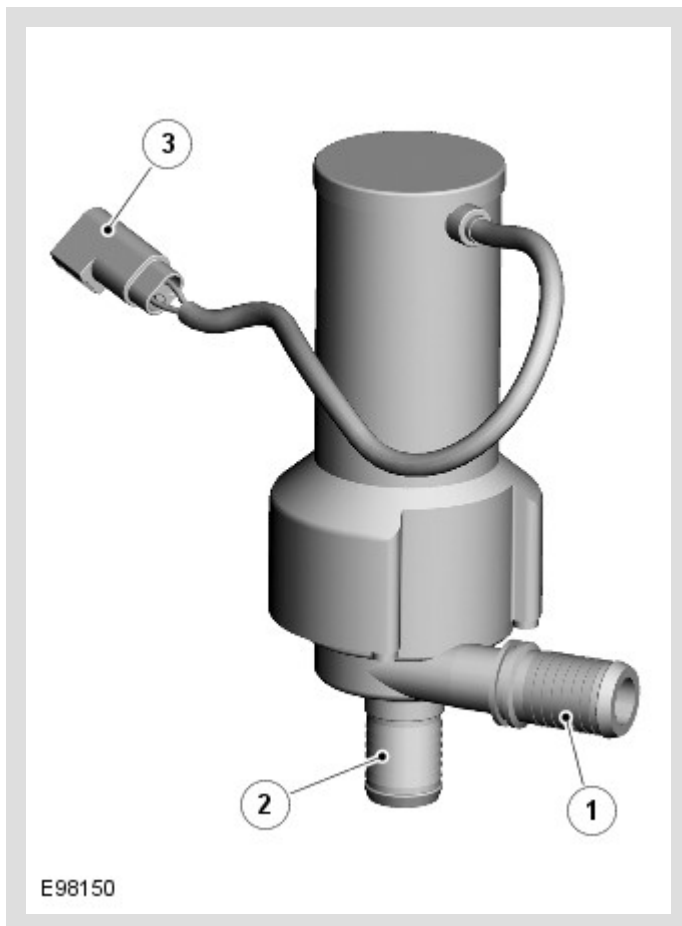

ITEM	DESCRIPTION
1	Coolant outlet connection
2	Coolant inlet connection
3	Electrical connector

The charge air coolant pump is an electric pump attached to the RH (right-hand) side of the charge air radiator. Hoses connect the inlet of the charge air coolant pump to the charge air radiator, and the

outlet to the charge air coolers. An electrical connector provides the interface between the motor of the charge air coolant pump and the vehicle wiring.

## CHARGE AIR RADIATOR

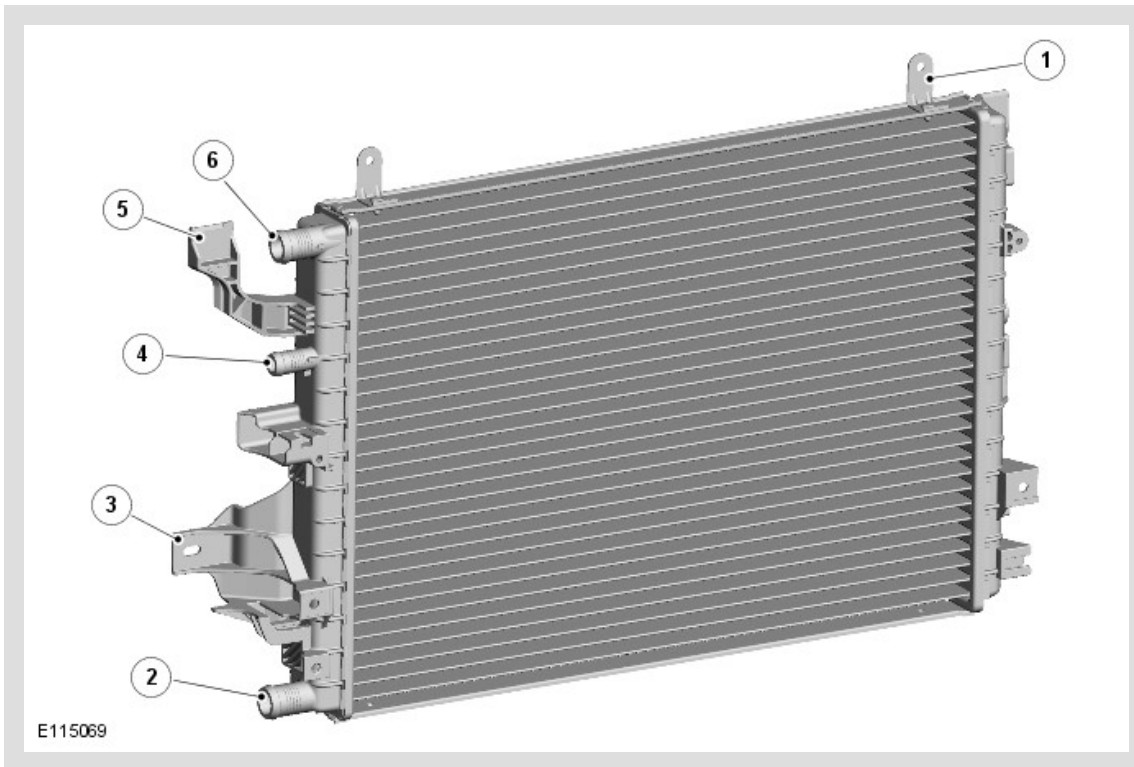

ITEM	DESCRIPTION
1	Pipe clip bracket (2 off)
2	Coolant outlet connection
3	Lower attachment bracket (2 off)
4	Coolant inlet connection
5	Upper attachment bracket (2 off)
6	Expansion hose connection (with engine cooling system)

The charge air radiator is a cross flow type with an aluminum core and plastic end tanks. The charge air radiator is installed in the cooling module, in front of the A/C (air conditioning) condenser. Brackets on the end tanks attach the charge air radiator to the front of the engine cooling system radiator.

The RH end tank incorporates the coolant inlet and outlet connections, and a connection for the hose to the engine cooling system. Hoses connect the inlet of the charge air radiator to the charge air coolers, and the outlet to the charge air coolant pump.

## CHARGE AIR COOLERS

A charge air cooler is installed in each intake manifold. Refer to: Intake Air Distribution and Filtering (303-12F, Description and Operation).

