

Instruments . . . . .	4-3	Starting/Stopping the Vehicle . . . . .	4-43
Warning Lights . . . . .	4-5	Automatic Transmission . . . . .	4-44
Audible Warnings . . . . .	4-11	Sport Mode . . . . .	4-46
Message Centre . . . . .	4-13	Dynamic Stability Control (DSC) . . . . .	4-47
Trip Computer . . . . .	4-14	Anti-lock Braking System (ABS) . . . . .	4-48
Messages . . . . .	4-17	Cruise (Speed) Control . . . . .	4-50
Exterior Lighting . . . . .	4-24	Adaptive Cruise Control (ACC) (where fitted) . . . . .	4-52
Interior Lighting . . . . .	4-28	Vehicle Suspension . . . . .	4-59
Window Operation . . . . .	4-30	General Driving Information . . . . .	4-60
Wipers and Washers . . . . .	4-32	Winter Driving . . . . .	4-62
Sunroof . . . . .	4-34	Touring . . . . .	4-62
Parkbrake . . . . .	4-35	Towing a Caravan or Trailer . . . . .	4-63
Park Distance Control . . . . .	4-36	Fuel and Refuelling . . . . .	4-65
Interior Features . . . . .	4-38		

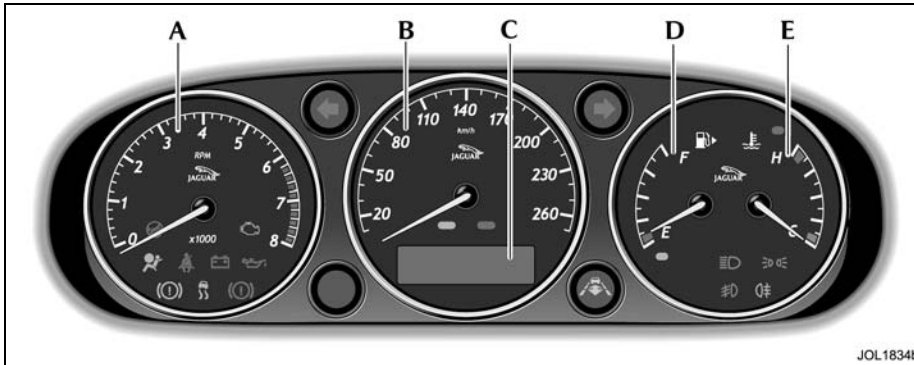



JAGUAR



## Instruments

None of the instruments will show correct indications until the ignition is switched ON (position 'II').

If the exterior light switch is ON and the ignition is ON, the display brightness can be varied using the dimmer switch (page 4-26).

## Tachometer (A)

The tachometer indicates engine speed in revolutions per minute and is calibrated in increments of 250 rev/min extending to 8000 rev/min (to 7000 rev/min for supercharged vehicles).

**Caution: Do not allow the needle to enter the red sector.**

## Speedometer (B)

Speed indication is in either:

- Kilometres per hour only, or,
- Kilometres per hour, the outer figures, and miles per hour or,
- Miles per hour, the outer figures, and kilometres per hour.

## Odometer (C)

Records the total distance covered by the vehicle.

The odometer reading is displayed below the speedometer, along with the trip distance since it was last reset.

To reset the trip distance, press the reset button on the trip computer switchpack. The trip distance will roll-over at 16,090 kilometres (or 9999.9 miles).

The odometer is displayed in the message centre unless a message has priority or a trip computer function has been selected.

## Fuel Level Gauge (D)

Indicates the amount of fuel in the tank.

A warning light is displayed in the gauge when the fuel in the tank is at a low level. The tank should be refilled at the earliest opportunity.

The small arrow, shown beside the fuel pump symbol, identifies on which side of the vehicle the filler cap is located.

## 4-4 On the Road

---

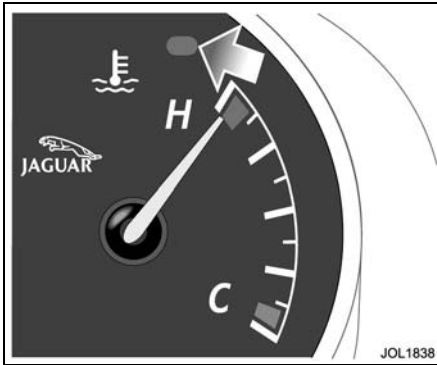

### Engine Temperature (E)

Drive at moderate road and engine speeds until normal operating temperature is reached. This is indicated when the pointer is between the blue (cold) segment and the red (hot) segment.

The engine operating temperature will vary with changes in weather and engine load. The engine temperature may rise in some circumstances, such as:

- Idling for long periods in slow moving traffic.
- Driving up a long hill in hot weather.
- Driving slowly or stopping after driving at high speed.
- Towing a trailer or caravan.

Should the pointer move into the red segment (H) of the coolant gauge, stop the vehicle as soon as it is safely possible, turn off the engine and open the bonnet to allow the engine to cool.



### WARNING:

1. The radiator cooling fans may continue to run after the ignition has been switched off but will automatically switch off when the engine has cooled sufficiently.
2. It is unsafe to run the engine in an overheated condition.
3. Do not remove the coolant reservoir filler cap while the engine is hot. If it is essential, then protect your hands against escaping steam. SLOWLY turn the cap anti-clockwise to allow the steam pressure to escape completely before removing the cap.

## Warning Lights

Warning lights are arranged within the instrument cluster.

There are two warning lights, one red, the other amber, located above the message centre for primary and secondary status of the warnings displayed by the message centre.

‘RED’ warning lights are for primary warnings. A primary warning must be investigated immediately by the driver or a Jaguar Dealer.

‘AMBER’ warning lights are for secondary warnings when the driver must take action and then report the fault to a Dealer at the earliest opportunity.

Other lights within the instrument cluster indicate system status, such as blue for main beam and green for direction indicators, when in operation.

## Lamp check

A lamp check is initiated when the ignition is switched ON and lasts for three seconds (except the airbag warning light which will remain on for 6 seconds). If any warning light remains on after this period, investigate the cause before driving.

**Note:** Not all lamps are included in the lamp check, for example main beam headlights or direction indicators.

## Low Oil Pressure (RED)



This lights up with the ignition switched ON and should go out once the engine is running.

If the light remains ON once the engine has started or comes ON whilst driving, loss of oil pressure is indicated. STOP the engine immediately and investigate the cause.

**Caution: Do not restart the engine until the cause of loss of oil pressure has been identified and rectified.**

First check the engine oil level, see page 7-7.

## 4-6 On the Road

---

### Charge Indicator (RED)



Lights up when the ignition is ON and should go out when the engine is running.

If the light stays ON when the engine is running it indicates that there is either a battery voltage fault or an alternator fault.

Turn OFF all electrical accessories, radio, climate control, rear screen heater etc. Try to use the minimum electrical load as possible such as power windows, electric sunroof etc. Report the fault to a Jaguar Dealer.

### Seat Belt (RED)



The warning lamp lights when the ignition is turned ON and:

- The driver's seat belt is not fastened.
- A passenger is sitting in the front seat and their seat belt is not fastened.

The light should go out when the driver's seat belt (and the front passenger's if the seat is occupied) is fastened.

**Note:** The vehicle must be moving above 16 km/h (10 mph) for the lamp to illuminate if the passenger seat belt is not fastened.

### Beltminder

The Beltminder feature is a supplemental warning to the seat belt warning function. This feature provides additional reminders to the driver that the driver's and/or front passenger's seat belt is unbuckled by intermittently sounding a chime and illuminating the seat belt warning light in the instrument cluster.

If the vehicle is moving above 16 km/h (10 mph) and one or both front seats are occupied and a seat belt is not fastened, a warning chime will be heard and the light will flash.

The chime sound and the light flashing will last for 10 seconds and then repeat every 30 seconds for five minutes or until the belts are fastened or the vehicle stops.

If the warning light stays ON steady with the seat belt(s) fastened, report the fault to a Jaguar Dealer. It is safe to drive the vehicle with the light ON steady, provided that the seat belt(s) is properly fastened. Ensure that all occupants seat belts are fastened before driving.

Although not advisable, it is possible to disable or reinstate the Beltminder function. Please see a Jaguar Dealer.

**Note:** If a heavy object is placed on the front passenger seat it may activate the Beltminder feature. It is recommended that the object be placed in the luggage compartment.

It is safe to drive the vehicle with the light ON steady, provided that the seat belt(s) is properly fastened. Ensure that all occupants seat belts are fastened before driving.

Although not advisable, it is possible to disable the seat belt minder function, as follows:

**Note:** This complete procedure must be completed within 60 seconds.

1. With the front passenger seat unoccupied, turn on the ignition but do not start the engine.
2. Buckle the driver's seat belt and ensure that the warning lamp is extinguished.
3. Now unbuckle the driver's seat belt and wait until the warning lamp comes on.
4. Repeat steps 2 and 3 eight more times.
5. As the seat belt is unbuckled for the ninth time, a single chime will sound acknowledging that the seat belt minder has been disabled.

**Note:** If the steps above are repeated the seat belt minder function will be reinstated.

## Brake (RED)



Lights up when:

- The ignition is ON and the parkbrake is ON.
- There is a fault with the parkbrake.
- The brake fluid is low.

If the light is ON and there are no associated messages it means that the parkbrake is applied.

If the light flashes, there is a fault with the parkbrake system and the parkbrake cannot be applied.

If the light is ON and the message 'PARKBRAKE ON' is displayed, it means that the parkbrake is applied but the vehicle is moving. Release the parkbrake or stop the vehicle when it is safe to do so.

If the light is ON and the message 'LOW BRAKE FLUID' message with a RED priority light is displayed on the message centre, low brake fluid is indicated. In this case, loss of braking in one, or both, brake circuits may be imminent.



**WARNING:**

**If the message 'LOW BRAKE FLUID' is displayed, DO NOT drive the vehicle until the fault is rectified. Consult a Jaguar Dealer immediately.**

## 4-8 On the Road

---

### Anti-lock Braking System (ABS) (AMBER)



If a fault has been detected in the anti-lock brake system (ABS) or the electric parkbrake system, this light will illuminate.

A warning message will appear with this light to indicate either ABS fault or parkbrake fault.

The brake system will continue to function normally, but without ABS braking.

Should the light come on or stay on after the bulb check cycle, stop the vehicle at the first opportunity, turn the engine OFF and then restart.

If the ABS light comes on again, the vehicle should be driven to a Jaguar Dealer at the earliest opportunity.



#### **WARNING:**

**If the ABS and brake warning lights are ON at the same time, DO NOT drive the vehicle until the fault is rectified. Consult a Jaguar Dealer immediately.**

### Dynamic Stability Control (DSC) (AMBER)



The light will flash at the rate of twice a second when DSC is operating.

The message 'DSC NOT AVAILABLE' will be displayed and the light will be ON continuously when a fault is detected in the system.

If the system is turned OFF, a message 'DSC OFF' will be displayed for 4 seconds and the warning light will remain ON.

### Engine Malfunction (AMBER)



This light comes on when the ignition is on and remains on until the engine is started.

If the light comes on when the engine is running then there is an engine malfunction.

Specialised diagnostic equipment is required to repair such faults. Report the fault to a Jaguar Dealer.

The vehicle may go to 'limp-home' mode, with the possibility of reduced engine performance. Drive the vehicle with caution.

## ACC Follow Mode (AMBER)



If adaptive cruise control is active, lights up to indicate that the vehicle is in 'follow mode' and automatically maintaining the desired gap to the vehicle immediately ahead.

Only applicable to vehicles fitted with adaptive cruise control.

## Airbag (AMBER)



If the airbag system develops a fault, the warning light will flash and then come ON and remain on until the fault has been diagnosed and cleared.

Report the fault to a Jaguar Dealer immediately.

It is safe to drive the vehicle; however, in an accident the airbags may not operate.

## Sidelights (GREEN)



Illuminates when the sidelights or headlights are switched ON either manually or by the autolamp system, if fitted.

## Main Beam (BLUE)



Illuminates when the main beam headlights are switched ON or flashed ON.

## Front Fog Lights (GREEN)



Illuminates when the front fog lights are switched ON.

## Rear Fog Lights (AMBER)



Illuminates when the rear fog lights are switched ON.

## Direction Indicators (GREEN)



The appropriate indicator tell-tale will flash when the column switch is moved up or down to signal a right or left-hand turn.

If a direction indicator fails, the tell-tale will flash at twice the normal rate when that indicator is selected. A message will be shown that a bulb has failed. Fit a new bulb immediately.

### Note:

1. If a bulb has failed, the audible ticking will sound at twice the normal rate.
2. If a trailer or caravan is fitted and a direction indicator bulb fails then the tell-tale will flash at twice the normal rate and a message will be displayed that a rear indicator lamp has failed.

## Hazard Warning Lights

When the hazard warning is selected, both direction indicator tell-tales flash simultaneously.

## 4-10 On the Road

---

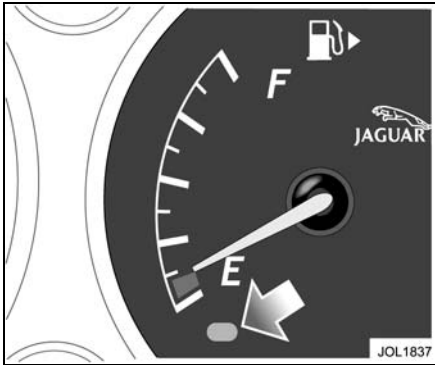

### Low Fuel Level

An amber warning light is displayed in the gauge when the fuel in the tank is at a low level. The tank should be refilled at the earliest opportunity.

### Overspeed Warning (Gulf Co-operation Council only) (AMBER)



Illuminates if the vehicle speed exceeds 120 km/h (75 mph).

## Audible Warnings

Various sounds are produced for warning and notification purposes as follows:

Hazard or Condition	Remedy/chime or tone
Airbag system failure.	A tone sequence is repeated five times. Report the fault to a Jaguar Dealer as soon as possible.
External lamps remain ON when the driver's door is opened.	A chime will sound for 10 seconds as a warning that the lights are on when the ignition is off and the driver's door is opened. <b>Note:</b> The chime will not sound if the switch is in autolamp position.
Hazard warning indicators ON.	A ticking will sound until the hazard indicators are switched OFF.
Vehicle armed.	This warns that the alarm will sound shortly unless the system is disarmed by either pressing the unlock button on the key transmitter or placing the key in the ignition switch.
Left or right direction indicators ON.	If the switch has not turned itself OFF, switch the turn indicator OFF when the manoeuvre is completed. A ticking will sound until the indicators are switched OFF.
Memory 1, 2 or 3 configuration saved.	A short tone as the memory selection is saved.
Valet mode.	This indicates that the valet mode has not been set or that access to a restricted area has been prevented because valet mode has been set.

## 4-12 On the Road

---

Hazard or Condition	Remedy/chime or tone
Seat belt reminder (not all countries).	A chime will sound for 6 seconds after the ignition is switched on or until the front seat belts, when occupied, are fastened or the ignition switch turned to '0'. The chime will also sound at regular intervals for five minutes if the vehicle is moving above 16 km/h (10 mph) and the driver's and/or front passenger's (if occupied) seat belts are not fastened or are unfastened.
Electric parkbrake.	If the message 'PARKBRAKE ON' is displayed, it means that the parkbrake is applied but the vehicle is moving. Release the parkbrake or stop the vehicle when it is safe to do so.
Parkbrake cannot be applied.	This sounds a warning that the parkbrake cannot be applied.
Adaptive cruise control driver intervene.	Action is required by the driver to apply the brakes.
Gear selector not in Park.	This warns that the gear selector is not in Park when the ignition is turned off.

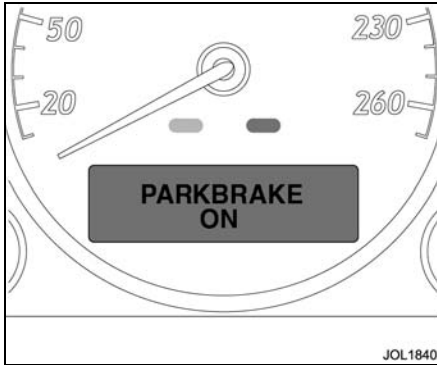

## Message Centre

Driver information, messages and data are displayed on the message centre display panel situated within the instrument cluster.

For the message centre to operate the ignition must be switched ON (position 'II').

The primary function of the message centre is to inform the driver of the following:

- Warning messages.
- Temporary alert messages.
- Information messages.

The message centre displays:

- The total distance covered by the vehicle.
- Trip computer information.
- Warning messages if system faults are detected.
- Status messages to indicate changes in state of certain vehicle functions.

## Messages



### WARNING:

**If a red warning light is displayed, investigate immediately and, if necessary, stop the vehicle as soon as possible but only when it is safe to do so.**

Most messages, when displayed, have an associated warning light, red or amber, above the display which will come on to indicate the message priority.

If more than one message is active, each is displayed in turn for two seconds in order of priority.

Messages take priority over the odometer reading or trip computer data and, if active, will be displayed when the ignition is switched ON.

## Message centre illumination

The message centre is lit at all times when the ignition is ON, and message brightness is controlled by the dimmer switch.

All information displayed will be brightly lit if the exterior light switch is OFF.

**Note:** Warning lights are always brightly lit and are not affected by the dimmer switch.

## Language Selection

The displayed language can be changed to another language, if required.

Press the ML/km button on the trip computer switchpack and whilst pressing, turn on the ignition to position 'II'. Now press the ML/km button, each press will display a different language. When the desired language is shown, press the A/B button. After three seconds the new language will be displayed for every message.

**Note:** If you wish to exit the language changing procedure and keep the original language, do not press the A/B button but wait 10 seconds or turn the ignition off.

## 4-14 On the Road

---

### Trip Computer

The computer memory stores data for a journey or series of journeys until it is reset to zero.

The displayed information is for guidance only, as it can be affected by traffic, road and weather conditions.

Two independent memories are available (A and B) to allow two separate journeys to be recorded concurrently, for example, work usage and evening/weekend usage.

Trip distance, average fuel economy and average speed will be prefixed A or B depending on the current memory selected.

Press the TRIP button on the end of the left column stalk switch repeatedly to display the data in the following order:

- Odometer.
- Trip distance.
- Range.
- Current fuel consumption.
- Average fuel economy.
- Average speed.
- Messages.

### Odometer

The odometer shows the total vehicle distance travelled since the vehicle was new.

When the ignition is switched ON (position 'II') the display shows the odometer reading unless another trip computer function was previously selected or a warning message is displayed, for example, 'PASSENGER DOOR OPEN'.

The odometer reading is displayed in either miles or kilometres, depending on the units selected with the trip computer.

### Trip Distance (A/B)

Distance travelled since the last memory reset. The maximum trip reading is 16,090 kilometres (9999.9 miles).

The computer, either A or B, will automatically reset to zero if this distance is exceeded.

### Range

Predicted distance, kilometres or miles, that the vehicle should travel on the remaining fuel, assuming average fuel economy and fuel consumption stay constant.

### Current Fuel Consumption

Instantaneous or 'at the moment' fuel consumption, which is continuously updated.

### Average Fuel Economy (A/B)

The average fuel consumption, litres per 100 kilometres or miles per gallon, based on the accumulated distance travelled and the accumulated fuel used.

### Average Speed (A/B)

The average speed since the last press of the reset button.



## Trip Computer Switchpack

### ML/km

Pressing the 'ML/km' button alternately displays data in metric or imperial units.

### A/B

Selects either A or B trip memory. Select the required data using the column stalk TRIP button and then pressing A/B will show the A or B information for that data.

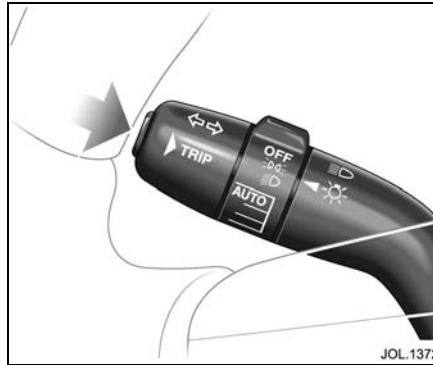

## RESET

- One short press clears (hides) the displayed message. Continue to give brief presses to clear one message after another until all messages are cleared.
- Press and hold for three seconds to reset or clear the selected trip, A or B, to zero.

**Note:** If warning messages are hidden, the warning/fault still exists and requires investigation.

Warning and Information messages have priority over trip data and, if active, will be displayed when the ignition is at position 'II'.

## Setting the Trip Computer

At the start of the journey, or series of journeys, to be recorded, reset the computer memory to zero as follows:

1. Press the TRIP button on the end of the left column stalk switch to select a trip function. The computer will display either TRIP A: or TRIP B: data.
2. Press the A/B button to select the trip (A or B) to be reset.
3. Press the RESET button and hold for 3 seconds.

The display will read:  
RESETTING  
TRIP A (or B).

Then it will reset and display:  
A: 0 (or B: 0) or the new value.

**Note:** All trip functions, for A or B depending on which was selected, will be reset.

## 4-16 On the Road

---

### Clearing Messages

Messages can be hidden by pressing RESET on the trip computer switchpack.

One press will hide one message.

Once all messages have been hidden, the display will show trip data, a further press will display the odometer reading.

If RESET is pressed again, all active messages will be 're-displayed'.

Repeatedly pressing the RESET button will cycle through the trip, odometer and message modes.

If a fault occurs when in trip computer or odometer mode, the relevant message will be displayed immediately.

If a trip computer function is selected by pressing the TRIP button while messages are displayed, the trip data will be displayed for 10 seconds, then the message will reappear.

**Note:** Hidden messages reappear after an ignition OFF/ON cycle, if the fault remains.

## Messages

The table on this and the following pages lists all messages and warning lights and explains their meaning.

Message	Warning Light	Priority Indicator	Meaning
LOW BRAKE FLUID	Brake	Red	<p>Displayed when the brake fluid level is low. Complete loss of braking may occur.</p> <p> <b>WARNING:</b>  <b>DO NOT drive the vehicle until the fault is rectified. Consult a Jaguar Dealer immediately.</b></p>
ENGINE COOLANT LOW	None	Red	<p>Displayed when the coolant level in the reservoir is too low or is empty. Check temperature gauge often. The coolant reservoir should be topped up at the earliest opportunity and any leaks repaired.</p>
CATS SYSTEM FAULT	None	Amber	<p>Displayed when a fault is detected in the adaptive damping (CATS) system (only those vehicles fitted with adaptive damping suspension). Report the fault to a Jaguar Dealer at the earliest opportunity.</p>
RESTRICTED PERFORMANCE	None	Red	<p>This will be displayed when the vehicle has possible loss of power or driveability. Report the fault to a Jaguar Dealer.</p>
ENGINE SYSTEMS FAULT	Malfunction Indicator light	Red	<p>Displayed when the engine has defaulted to 'limp-home' mode. Report the fault to a Jaguar Dealer at the earliest opportunity.</p>

## 4-18 On the Road

---

Message	Warning Light	Priority Indicator	Meaning
AIR SUSPENSION FAULT	None	Amber	Drive the vehicle with caution and inform your nearest Jaguar Dealer to have the fault rectified.
VEHICLE TOO LOW	None	Red	The air suspension system is too low. Start the engine and wait for the message to clear before driving the vehicle. If the message is displayed while you are driving, restrict your speed until the message is cleared. If the message is persistently shown, inform your Dealer.
DRIVERS (or PASSENGERS) DOOR OPEN	None	Red	The driver's and/or one or more passenger doors are open. Check that all doors are closed before driving.
BOOT OPEN	None	Red	Check that the luggage compartment lid is closed before driving.
BONNET OPEN	None	Red	Check that the bonnet is closed before driving.
ABS FAULT	ABS	Amber	ABS will not be available. The braking system will work but care must be used if braking heavily.
STEERING COLUMN LOCKED	None	Amber	The steering lock system has failed to unlock the steering column. The engine cannot be started. Remove the key and re-insert it into the ignition switch, then try again to unlock the column by turning the steering wheel gently to the left and right (only small movements will be possible).

Message	Warning Light	Priority Indicator	Meaning
GEARBOX FAULT	None	Amber	It is likely that the driver will experience a degradation of transmission operation and possibly reduced acceleration capability.
DSC NOT AVAILABLE	Stability Control	Amber	Displayed when a fault occurs in the stability control system.
DSC ON (or OFF)	Stability Control	Amber (OFF only)	Displayed when the stability control system is switched ON or OFF. The warning light will FLASH when the stability control system is switched ON and operating. When the system is switched OFF, the warning light in the instrument cluster will be illuminated until the system is switched back ON.
WASHER FLUID LOW	Low washer fluid level	Amber	Indicates that the windscreen wash fluid level is low. If wash/wipe is selected when this message is displayed (even if it has been cleared from the message centre), the programmed wipe after washing will not operate. This is to avoid smearing the windscreen if the reservoir is empty. Top up the washer fluid at the earliest opportunity.
VALET MODE	None	None	Indicates that the valet switch is selected on. It also indicates that an attempt has been made to open the luggage compartment using the interior release whilst valet mode is selected.
CHECK FUEL FILLER CAP	None	Amber	The fuel filler cap may be loose or leaking excessively.

## 4-20 On the Road

---

Message	Warning Light	Priority Indicator	Meaning
<p><b>Note:</b> In most countries it is illegal to use a vehicle with a defective exterior lamp bulb. Bulb replacement information starts on page 6-14.</p>			
FAILED FRONT LH (or RH) INDICATOR	None	Amber	Check for any failed front direction indicator lamps and replace.
FAILED REAR LH (or RH) INDICATOR	None	Amber	Check for any failed rear direction indicator lamps and replace. <b>Note:</b> This also applies to any trailer/caravan lamps.
FAILED LEFT (or RIGHT) SIDE REPEATER	None	Amber	Check for failed side direction indicator repeater lamps and replace.
LIGHTS ARE OFF	None	Amber	This is displayed with the ignition on, the headlights in the OFF position and it is dark or ambient light level is low. This message is displayed only when the lights would be on if the switch were in AUTO position. It is a reminder to drivers who normally leave autolamp selected on and may not be aware that it has been turned off.
APPLY PARKBRAKE	None	Amber	If the battery has been disconnected then the parkbrake must be applied to reset the system.
PARKBRAKE FAULT	None	Red	Displayed when there is a fault in the parkbrake system. If the red brake warning light is flashing the parkbrake cannot be applied.

Message	Warning Light	Priority Indicator	Meaning
PARKBRAKE ON	Brake	None	Displayed if the parkbrake is applied whilst the vehicle is moving above 3 km/h (2 mph). Release the parkbrake.
LISTENING	None	None	When Voice Activation has been selected and the system is waiting for a voice command/input.
COLUMN ADJUST	None	None	The column adjust switch has been moved to this position.
COLUMN ADJUST AUTO	None	None	The column adjust switch has been moved to this position.
PEDAL ADJUST	None	None	The column adjust switch has been moved to this position.
PEDAL ADJUST INHIBITED	None	None	The pedals cannot be adjusted when the vehicle is in cruise control operation.
AUTOLAMP DELAY OFF	None	None	Autolamp delay function has been turned off.
AUTOLAMP DELAY X:XX	None	None	Changing the time delay will display the newly set time that the headlights will remain ON after exiting the vehicle.
CRUISE ENGAGED	None	None	Displayed when cruise control system is operating.

## 4-22 On the Road

---

Message	Warning Light	Priority Indicator	Meaning
CRUISE CANCELLED	None	None	Driver has cancelled cruise control or is braking.
CRUISE OVERRIDE	None	None	Driver is pressing the accelerator pedal.

The following messages only apply to vehicles fitted with adaptive cruise control.

DRIVER INTERVENE		Red	Action by the driver to apply the brakes is required.
SETSPEED XXX KM/H		None	Speed set for adaptive cruise control.
GAP ← - →		None	Set the distance (time gap).
ACC SENSOR BLOCKED		Amber	Clean the front of the vehicle in the area of the sensor unit (the sensor is mounted behind the left-hand cover in the lower cooling air inlet).
CRUISE NOT AVAILABLE		Amber	Adaptive cruise malfunction.

Message	Warning Light	Priority Indicator	Meaning
FORWARD ALERT ON (or OFF)		None	Forward alert feature has been switched ON or OFF. A warning will not be given for objects detected in the vehicle path of travel if forward alert is switched OFF.
FORWARD ALERT ← — →		None	Forward alert feature has been switched ON or the setting changed. A warning will be given for objects detected in the vehicle path of travel. A longer gap indicates that the system will warn when detected objects are further away than the previous setting.

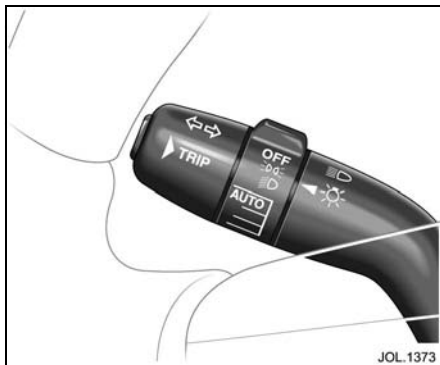

### Exterior Lighting

#### Master Lighting Rotary Switch Positions

- OFF.
- Side (parking) lights.
- Headlights.
- Autolamps/exit delay.



#### WARNING:

It is an offence in certain countries to obscure front and rear lights, direction indicators and reflectors.

The exterior lights are controlled by the left-hand column stalk switch.

The rotary collar on the stalk has three positions for turning the exterior lights on or off and positions for autolamps/exit delay. These are:

**OFF** – All exterior lights OFF (except vehicles provided with daylight running lights).

**Sidelights** – Switches on front sidelights, tail, number plate and any other marker lights required by local legislation.

When the external lights are ON the instruments will also be lit.

**Headlights** – With the ignition in position 'II', this position switches on dipped headlights in addition to the lights switched on in sidelight position.

The left-hand column stalk switch has two positions for controlling the main beam.

Pulling the switch towards the steering wheel and releasing causes the main beam to flash on and off. The main beam can be flashed at any time when the switch is pulled and will remain ON for as long as the switch is held.

The second position is to switch main beam headlights ON. With the ignition in position 'II', first select dipped beam lights, and then push the column light switch away from the steering wheel.

The blue warning light on the instrument cluster and the main beam headlights will come ON.

To turn main beam OFF, pull the column switch towards the steering wheel to return to dipped beam.

**Note:** If dipped beam is switched OFF, with main beam still activated both dipped and main beam will be extinguished. Both dipped and main beam will illuminate if dipped is turned on again.

**Autolamps** – A light sensor control, mounted on the front of the fascia, monitors exterior light levels and automatically switches the sidelights and dipped headlights ON or OFF.

The ignition switch must be in position 'II' and AUTO selected on the stalk for full automatic light operation.

When light fades towards dusk, the sidelights and headlights will switch ON automatically and the sidelight warning light in the instrument cluster will illuminate.

At dawn, as light increases, the sidelights and headlights switch OFF automatically. Do not cover the sensor and keep the windscreen clean. Obstructing the light in this area of the sensor may lead to unwanted operation of the sidelights and headlights.

**Note:** If the windscreen wipers are switched on in auto, slow or fast modes for more than 20 seconds then the exterior lights will be switched on, if selected to autolamps mode. The lights will switch off 2 minutes after the wipers are switched off or will go off straight away if autolamps is deselected or the ignition is turned off.

### Exit delay

When parking the car at night, if the headlights were switched on then they will remain on for a short period after the key has been removed from the ignition switch. This is to give a clearly lit area for occupants leaving the vehicle.

If the light switch rotary collar is in the AUTO position there will be no exit delay and the headlights will turn off when the light switch is turned off.

Three settings on the rotary collar set the time that the lights will remain on after the key is removed from the ignition switch;

- 10 seconds.
- 30 seconds.
- 2 minutes.

**Note:** The key must not be in the ignition switch for this feature to operate.

The message centre shows the delay setting or when this feature is turned off.

### Headlight convenience

When approaching the vehicle, the sidelights and headlights can be switched on by pressing the headlight button on the remote transmitter.

The lights will come on for 25 seconds or can be switched off by pressing the remote transmitter headlight button again.

### Daylight running lights

In certain countries it is a legal requirement for the lights to be on during the hours of daylight.

With the rotary collar in the OFF position, dipped headlights, sidelights, tail lights, number plate lights and, where fitted, side marker lights will switch on automatically with the following conditions:

- The ignition is turned to position 'II'.
- The vehicle gear selector out of park.
- The parkbrake is not applied (released).

### Headlight levelling

No manual control of headlight levelling is required on this vehicle. The air suspension will keep the vehicle level.

## 4-26 On the Road

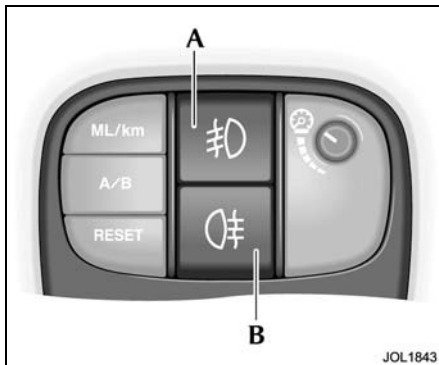

The fog lights can only be switched on when the ignition switch is in position 'II'.

### Front fog lights (A)

With the lights on in sidelight or dip position, press the switch (A) to turn on the front fog lights. Pushing the switch again will turn off the front fog lights.

A warning light in the instrument cluster indicates that the fog light is on.

If the sidelights are turned off, the fog lights will automatically turn off.

**Note:** The front fog lights should only be used when visibility is severely restricted by fog.

### Rear fog lights (B)

The rear fog lights can only be switched on if the dipped headlights are on or if front fog lights are switched on.

Press the switch (B) to turn on the rear fog lights. Pushing the switch again will turn off the rear fog lights.

A warning light in the instrument cluster indicates that the fog light is on.

When the side lights are switched off the fog lights will go off.

If the sidelights are left on but the ignition switch is turned to OFF the fog lights will switch off.

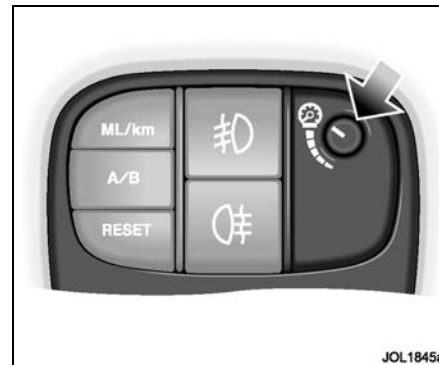

### Dimmer Switch

The instruments, switchpacks, in-car entertainment panel and climate control panel will be lit when the exterior lights are switched on.

Push and release the knob to extend it for ease of operation.

Rotate the knob to adjust the illumination to the required level.

Push the knob again to place it in the stowed position.

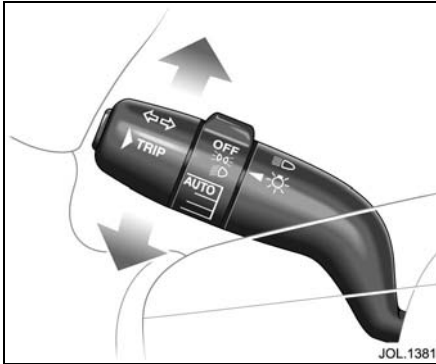

## Direction Indicators

The direction indicators, the left column stalk, operate when the ignition is in position 'II'. Move the stalk up for indicating a right turn or move it down to indicate a left turn.

Two positions are provided. The first position, partly moving the stalk up or down, causes the indicator to flash while it is held in this position. On releasing the stalk the indicators stop flashing.

The second position is a full movement of the stalk up or down, which can then be released. The indicators will remain flashing and will cancel when the turn is completed.

An audible ticking and a flashing green arrow on the instrument cluster indicates that the selected direction indicator is operating.

## Bulb failure

The direction indicators (including those on a trailer, if attached) and side repeaters are monitored for bulb failure. If a bulb fails when it is on, a message is shown in the message centre. At the same time, the corresponding side green warning light will flash at twice the normal rate. The audible ticking will sound at twice the normal rate.

## Door Guard/Puddle Lights

Door guard lights are fitted to each door to give warning of an open door to passing vehicles.

Puddle lights illuminate the 'step out' area at night.

Each light comes on automatically when the door is opened. If the door is left open the lights remain on for 5 minutes and then switch off.

## Approach Lights

Approach lights are fitted in the door mirrors to provide illumination for the floor area around the front doors.

The approach lights come on when:

- The vehicle is unlocked using a key, a key transmitter or the central locking switch.
- Using the headlight convenience button on the key transmitter.
- Reverse gear is selected.

The approach lights will not illuminate if the autolamp sensor determines that the ambient light is sufficiently bright.

## Luggage Compartment Lighting

The luggage compartment will be illuminated when the lid is opened.

## Glove Compartment

The glove compartment will be illuminated when the lid is opened.

## 4-28 On the Road

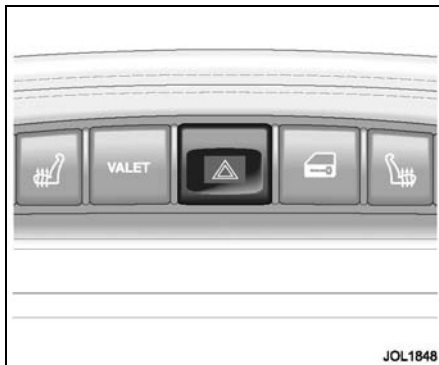

### Hazard Warning

The switch is in the centre console below the radio and operates with the ignition ON or OFF. Use only in an emergency to warn traffic of a vehicle breakdown or approaching danger.

To operate, press the switch.

The direction indicators, the instrument cluster green indicators and the audible warning will operate in unison.

The switch symbol will light up.

To cancel, press the switch again.

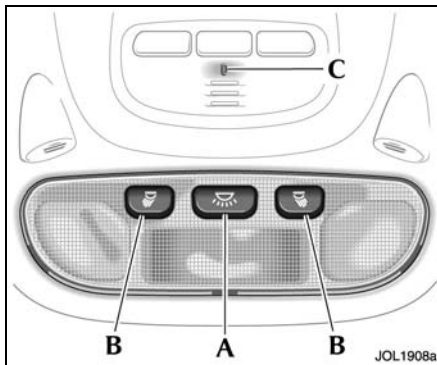

### Interior Lighting

Interior lighting comprises front overhead courtesy light and two front and two rear reading/map lights. Vanity mirror, glove compartment, footwell and luggage compartment lights are also provided.

The centre console area is illuminated by a small light from the overhead console (C). This is on whenever the sidelights are on and can be controlled by the dimmer switch.

Pressing the centre switch (A) in the overhead console turns the front and rear courtesy lights and footwell lamps on.

A second press turns the lamps off.

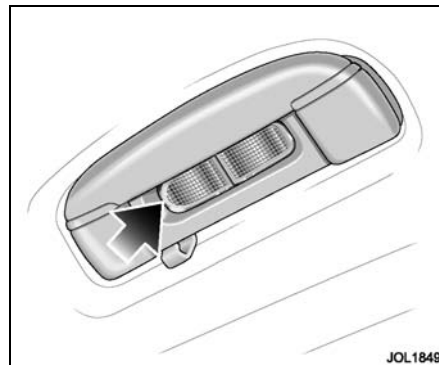

### Map/reading lights

The reading/map lights are turned on and off by individual switches (B). The reading/map lights will remain on for up to 15 minutes after the ignition has been turned off.

### Rear lighting

The rear interior lights can be switched on or off by pressing the lens cover.

### **Illuminated entry/exit**

The interior lights fade on when a door is opened and go out when the engine is started or 15 seconds after the last door is closed. If any door is left open, the lights will fade off after two minutes.

When the vehicle is unlocked with a key or the key transmitter, the courtesy lights will come on at maximum brightness for two minutes if a door is not opened.

With the engine running, opening any door will put on all interior lights, they will go out immediately after the last door is closed.

### **Battery Saver**

If the interior lights are switched on using the centre switch in the overhead console and the ignition switch is turned to position '0', the lights will automatically turn OFF after 40 minutes.

If the interior lights are switched on by opening a door and a key is left in the ignition switch in position '0', the lights will automatically turn off after 10 minutes.

If the glove compartment or vanity mirror lights are switched on and the ignition switch is turned to positions '0' or '1' or the key is removed, the lights will automatically turn OFF after 40 minutes.

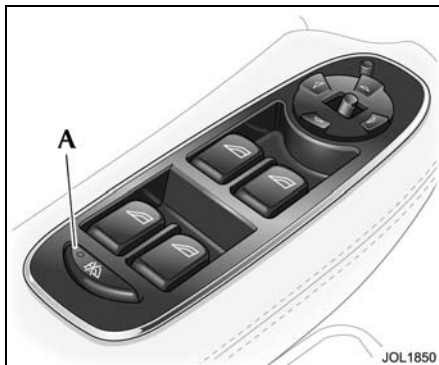

### Window Operation

The front and rear door windows are electrically operated by switches located on each door.

Switches on the driver's door control all door windows.

Passengers are provided with a switch to control their door window only.

These switches will only operate the windows when the ignition switch is in position 'I' or 'II'.

Button (A) immobilises operation of the rear windows (and front seat adjustment, when fitted) by rear seat occupants.



#### WARNING:

1. When raising windows ensure all occupants are clear.
2. When leaving the vehicle take the ignition keys to prevent misuse of the window switches by remaining occupants, especially children.

#### Raise/lower

Each switch has two positions to raise the window and two positions to lower the window.

To lower a window, press the switch downwards to the first position until the desired window position is reached, then release.

To raise a window, pull the switch upwards to the first position until the desired position is reached, then release.

If the switches are held for longer than 6 seconds, for example, when attempting to overcome frozen or jammed windows, the window drive will be switched off for a few seconds to protect the window drive motors.

The windows can be operated with the key removed from the ignition switch within 10 minutes of the vehicle being stopped provided the driver's or front passenger's door has not been opened. If a rear door is opened the windows can still be operated within the 10 minute period.

#### One-touch operation

Each window has a 'one-touch' facility enabling the occupant to fully open or close the window in one quick movement.

Press the switch briefly to the second position to fully open the window in one movement. Pull the switch briefly to the second position to fully close the window in one movement. Window travel can be stopped at any time by pressing the switch again.

## Immobilising the rear windows

To immobilise the rear windows (and operation of the front seat by a rear seat passenger, when this feature is fitted), press button (A) (see previous page illustration). The LED in the button will light up showing that the rear windows cannot be operated by rear seat occupants. Pressing the button again will enable occupants to operate the rear windows. See **Rear Seat Adjustment** on page 3-5.

## Window Anti-trap Protection

Each electrically operated window has an anti-trap protection feature. If the upward movement of the window detects an obstacle the anti-trap system will immediately stop the window closing, then move it downwards for a short distance.



### **WARNING:**

**If the battery is disconnected or discharged the window anti-trap feature is lost. When the battery is reconnected or recharged the window anti-trap system must be reset.**

## To reset the electrically operated windows anti-trap system

- Fully close the window, hold the switch in the close position for two seconds and then release the switch. Wait for two seconds, do not open the window.
- Again, select the same window to close, holding the switch for a further two seconds.
- Check to confirm the operation by opening the window and then use one-touch operation to close the window.
- Repeat for the remaining electrically operated windows.

## To override the anti-trap protection

The anti-trap system will also stop the window closing if a blockage or resistance occurs e.g. in the window guide channels. Typically this might be due to icing in winter but could also be caused by damage or misalignment of the guide channels or seals.

To override the anti-trap action:

- After the initial attempt to close the window, operate the close switch a second time.
- When the window has reversed from the blockage, operate the switch (within 10 seconds) until the window stops again (it will not reverse on the third attempt).
- Immediately operate the close switch again. The window will now move up a short distance with increased force to override the blockage.
- Repeat the override action until the window has closed. Each time the window stops, the switch must be operated immediately to initiate further override action.

If this procedure fails to move the blockage, the anti-trap feature will be lost and must be reset (see previous column) after the blockage has been cleared.

## Thermal overload

If the windows are repeatedly opened and closed (e.g. by a child), a protection system will deactivate window operation for a short period to avoid overheating of the window motors.

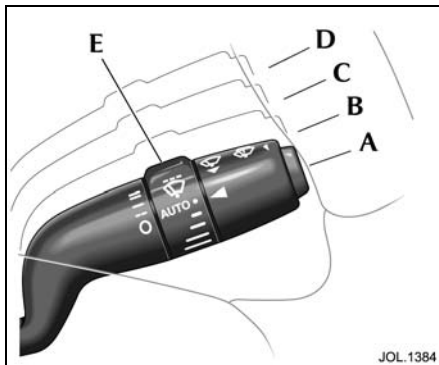

### Wipers and Washers

The windscreen wipers and screen wash functions are controlled by the right-hand column stalk switch and only operate with the ignition in position 'II'.

Moving the stalk up or down operates or turns off the windscreen wipers.

### Windscreen Wipers

The stalk functions are as follows:

Position (A):

The windscreen wipers are OFF and parked.

First position (B):

Intermittent wipe.

Second position (C):

Slow speed wiper operation.

Third position (D):

High speed wiper operation.

### Intermittent wipe

When intermittent wipe is selected the delay between wipes can be varied.

Turn the collar (E) to vary the delay from 3 seconds to 18 seconds.

### Flick wipe

Pull the column switch towards the steering wheel for a single wipe. Holding the column switch in this position will operate the wiper continuously at slow speed until released.

### Rain sensitive wiper control

When AUTO, (turn the rotary collar [E] to AUTO) and intermittent wipe are selected, the wipers will automatically operate to clear the windscreen when rain falls on to the windscreen, or when moisture is present.

For the wipers to operate, the ignition switch must be in position 'II'.

**Note:** When starting a journey with a wet windscreen, the rain sensing wipers will not operate immediately the ignition is switched on. Therefore, a flick wipe should be used to clear the windscreen of any moisture.

**Caution:** Ensure that AUTO is not selected when entering a car wash or damage to the wiper blades/arms can occur.

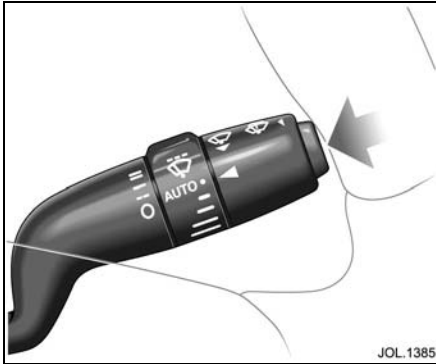

### Windscreen Wash/Wipe

Push the button on the end of the switch to obtain the wash/wipe programme.

If the wipers are selected off or intermittent, the washers will operate at slow speed during the washing action when the button is pressed. When the button is released, the wipers will complete up to three further wipes.

A single wipe will take place 4 seconds after the last wipe to clear any drips of water from the windscreen.

If rain sensitive wipers are fitted and selected then the wipers will operate until no moisture is detected.

### Headlight Powerwash

The headlight powerwash units (if fitted) are mounted between the front headlights.

The headlight powerwash feature will operate if the ignition is in position 'II' and dipped or main beam headlights are switched ON. It will not operate if the washer fluid level is low.

When the windscreen wash/wipe button is pressed, the headlight powerwash directs two short bursts, 3 seconds apart, at the headlights. If the wash/wipe button is held, the headlight wash cycle will continue for up to 20 seconds.

The headlight powerwash will operate the first time the wash/wipe button is pressed and thereafter every sixth succeeding wash/wipe operation. If the headlights or ignition are switched OFF and ON again, headlight powerwash will operate on the next press of the wash/wipe button.

**Note:** If the washer fluid level is low in the reservoir the windscreen wipers will not operate when windscreen wash is selected even though there may be washer fluid remaining in the reservoir and sprayed onto the screen. This is to prevent damage to the blades, or scratching of the glass, or smearing dirt across the screen.

## 4-34 On the Road

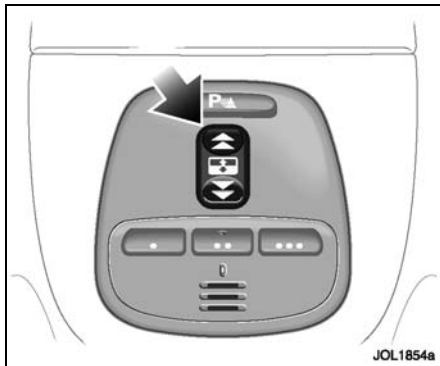

### Sunroof



#### WARNING:

1. Before opening or closing the sunroof check that all occupants are clear.
2. When leaving the vehicle take the ignition key to prevent misuse of the sunroof switch by remaining occupants, especially children.

The sunroof switch is located in the overhead console. The ignition switch must be in either position 'I' or 'II' for the sunroof to operate.

The sunroof has a 'one-touch' facility enabling the occupant to fully open or close the sunroof in one quick movement.

To open the sunroof:

- Push the rear of the switch gently upwards to the first position and hold until the sunroof is fully open. The sunroof can be stopped at any open position by releasing the switch.
- To fully open the sunroof with one-touch operation, briefly push the rear of the switch fully upwards to the second position and then release. To stop the sunroof opening, briefly press the switch upwards, forwards or rearwards.

To close the sunroof:

- Push the front of the switch upwards to the first position and hold until the sunroof is closed. It can be stopped at any position by releasing the switch.
- To close the sunroof with one-touch operation, briefly push the front of the switch upwards to the second position and then release. To stop the sunroof closing, press the switch upwards, forwards or rearwards.

To tilt the sunroof open:

- Push the front of the switch upwards and hold until the required position is reached, or until the tilt is fully open, and then release the switch.

To tilt open with one-touch operation:

- Briefly push the switch upwards to the second position.

To close the tilted sunroof:

- Push and hold the rear of the switch until the sunroof is closed. Briefly push the rear of the switch upwards to the second position to tilt closed with one-touch operation.

### Sunshade Operation

The sunshade can be manually opened and closed using the pull cup.

**Note:** When the sunroof is fully open the sunshade is also fully open and, because the pull cup is hidden, it cannot be manually closed from this position. The sunroof will need to be fully closed to gain access to the pull cup.

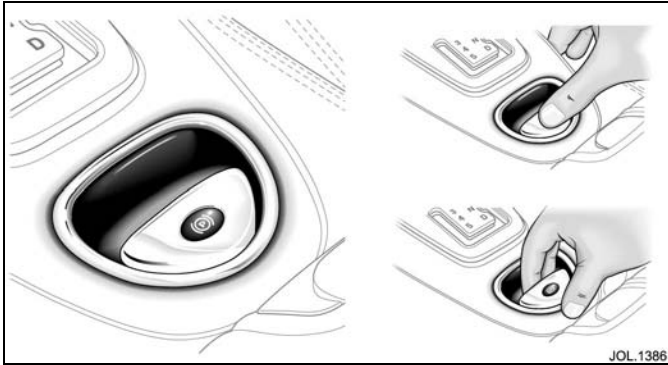

## Parkbrake

The switch which operates the parkbrake is mounted on the centre console to the rear of the gear selector.

To engage the parkbrake, pull the parkbrake switch upwards and release. The switch will return to the neutral position. The parkbrake warning/brake fluid low warning light on the instrument cluster will illuminate.

To disengage the parkbrake, with the ignition switch in position 'II' or with the engine running, apply the footbrake and press the parkbrake switch down.

The parkbrake is automatically released when the gear selector is moved from the Park 'P' position.

If the vehicle is stationary and the gear selector is in 'D' or 'R' and the parkbrake is applied, then the parkbrake will automatically release when the accelerator pedal is depressed.

Inadvertent operation of the parkbrake whilst the vehicle is in motion will cause the message 'PARKBRAKE ON' to be displayed on the message centre, the warning light in the instrument cluster will be illuminated and a warning chime will sound.

If the parkbrake is applied whilst the vehicle is moving, push the switch down to release it. If the switch is in the neutral position after parkbrake application, depressing the accelerator pedal will release the parkbrake.

**Note:** If the vehicle is in motion, the parkbrake should only be used as an emergency brake.

The parkbrake is automatically applied when the key is removed from the ignition switch. If you wish to keep the parkbrake off, press and hold the parkbrake switch down and, at the same time, remove the key.

**Caution:** Take care that the vehicle is safely parked to prevent it from rolling if you wish to leave the parkbrake off.

The warning light in the instrument cluster will remain on for a short time if the parkbrake is applied when the key is turned to position '0' or if the key is removed.

If the battery has been discharged or disconnected the message 'APPLY PARKBRAKE' will be displayed when the ignition is next switched on. Depress the footbrake and pull the parkbrake switch up to apply the parkbrake. This is required to reset the parkbrake system which will now function correctly.

### Park Distance Control

**Caution:** It remains the driver's responsibility to detect obstacles and estimate the car's distance from them. Some overhanging objects, barriers, thin obstructions or painted surfaces which could possibly cause damage to the vehicle may not be detected by the system. Always be vigilant when reversing.

Park distance control is always automatically switched on when the ignition is turned on.

**Caution:**

1. If, for example, you are driving into a confined space such as a home garage, the outer sensors will detect the side walls and after 3 seconds will switch the tone off. However, as movement continues, the inner sensors will eventually detect the rear wall and will start the tone again.
2. The sensors are not active when the gear selector is in neutral, therefore, take care if moving the vehicle as the tone will not be heard.
3. Do not clean the sensors with abrasive or sharp objects.

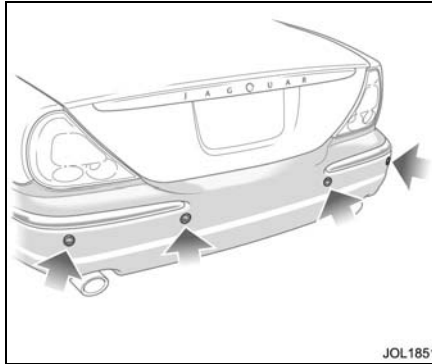

JOL1851

**Note:**

1. For reliable operation, the sensors in the front (if fitted) and rear bumpers should be kept free from frost, ice and grime.
2. When using a high pressure spray the sensors should only be sprayed briefly and at least 20 cm (8 inches) distance from the sensors.
3. The front parking aid may sound spurious tones if it detects a frequency tone using the same band as the sensors.

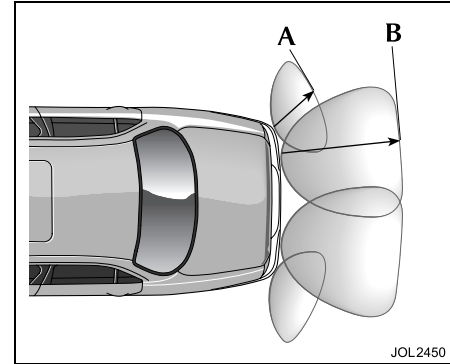

JOL2450

### Rear Park Distance Control

When reverse gear is selected and ignition is on, rear park distance control automatically provides an audible proximity warning (to the nearest detected obstacle) when reversing the vehicle, if obstacles are detected within the operating range, shown in the illustration above (between approximately 60 cm (24 inches) and 160 cm (63 inches)).

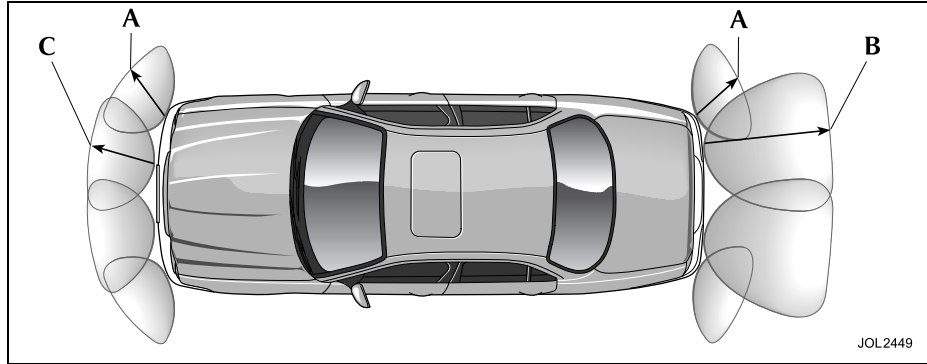
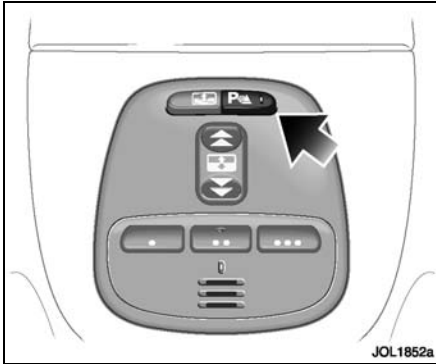

### Front and Rear Park Distance Control

When both front and rear park distance control are fitted, a switch is located in the overhead console.

Pressing the switch turns front and rear park distance control on or off together. The switch integral warning lamp will come on when the system is turned off or if a fault is detected in the system. A switch is not provided when only rear park distance control is fitted.

**Note:** The front park distance control will also operate when reverse gear is selected.

Front park distance control provides an audible proximity warning when driving forwards if objects are detected within the operating range shown in the illustration above (between approximately 60 cm (24 inches) (A) and 80 cm (31 inches) (C) to the front of the vehicle). The front sensors only operate within a fixed speed range in forward gears and are not effective when moving forwards above 15 km/h (9 mph) or when slowing down until below 7 km/h (4½ mph).

If an obstacle is detected at the front or rear of the vehicle, a beep tone will be heard from the front or rear speaker respectively, which increases in rate as the vehicle approaches the obstacle.

The front or rear park distance control beep will become continuous when the obstacle is detected at or within 30 cm (12 inches) from the rear or approximate 25 cm (10 inches) from the front of the vehicle.

If the system has a fault when engaging reverse gear or turning on the ignition, then a single, three second tone will be heard (only once per ignition cycle) and, if fitted, the switch lamp will come on. The system is automatically disabled when a fault is detected.

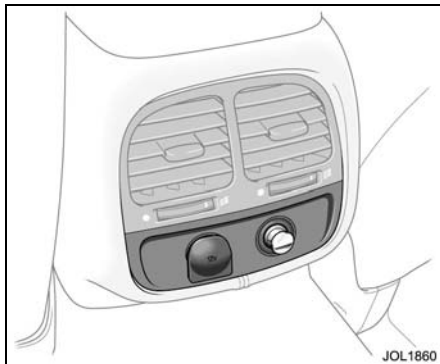

### Interior Features

#### Accessory Power Points

There are two sockets to provide a power source for accessories, such as a 12-volt vacuum cleaner or mobile phone.

One is fitted to the end of the centre console to the left of the cigar lighter, beneath a flip lid.

The other accessories socket is located in the glove compartment (not shown).

Do not use any cigar lighter socket for connecting accessories as it can be damaged.

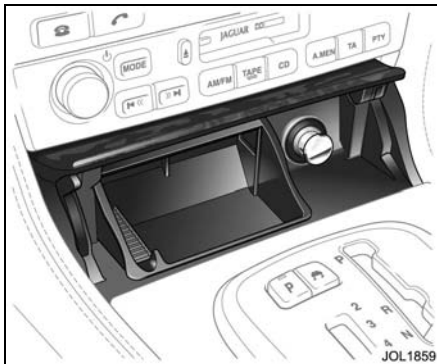

### Cigar Lighter and Ashtray

Push the lid to gain access to the front cigar lighter and ashtray. To operate the cigar lighter the ignition must be on, press the lighter in and wait until the element has heated, it will then pop-up.

**Note:** Never hold the lighter knob down. Do not attempt to remove particles from the heating element as it is self-cleaning. The cigar lighter is designed to be used just to heat the lighter element and not for providing a power source for accessories.

To empty the ashtray, lift it out vertically and remove. After emptying, push the ashtray into the opening until it snaps back into place.

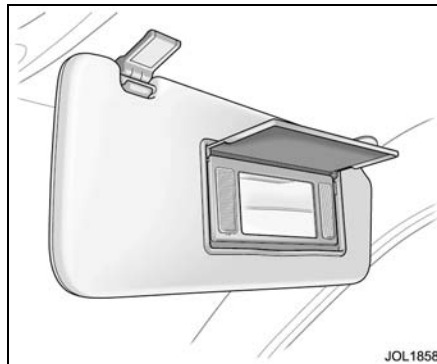

### Sun Visors and Vanity Mirrors

Adjustable sun visors can be swung downwards or unclipped and swung sideways to reduce sun glare.

The sun visors are fitted with illuminated vanity mirrors, behind a hinged flap. The light comes on when the flap is lifted.

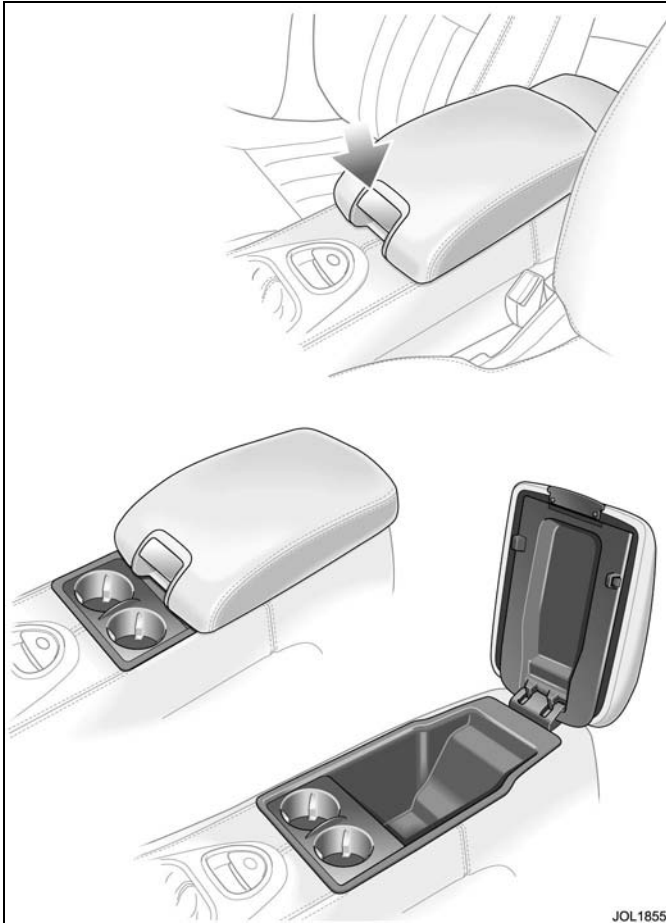

JOL1855

## Centre Console

The centre console carries the armrest, cupholders, the cubby box and (where fitted) the phone. At the rear of the centre console is a cigar lighter and accessory power point.

### Cupholders



**WARNING:**

1. **Do not place hot drinks in the cupholders whilst the vehicle is moving, there is a risk of scalding.**
2. **Use soft cups only.**

The sliding armrest is hinged at the rear and has a release button located on the front of the armrest. The chromed button is pulled upwards to raise the armrest and gain access to the cubby box and (when fitted) the telephone.

To expose the two cupholders, slide the armrest rearwards.

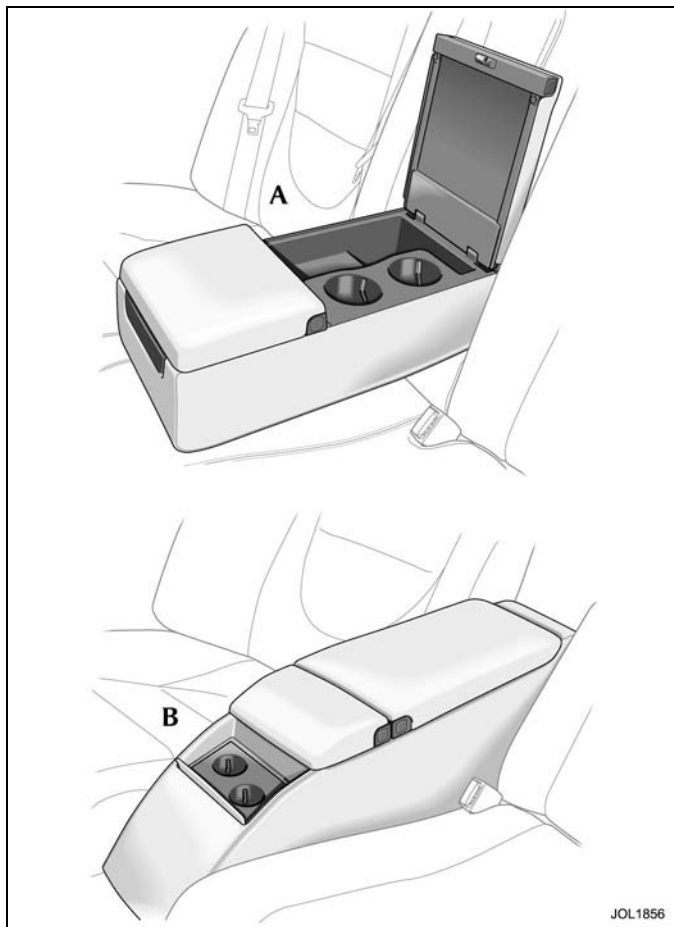

### Rear Armrest



1. Do not place hot drinks in the cupholders whilst the vehicle is moving, there is a risk of scalding.
2. Use only soft cups and cool liquids.

Depending on vehicle specification there can either be a rear armrest or a rear centre console fitted.

To access the cupholders in the rear armrest (A), press the two buttons on the rear hinged lid and raise it. The cupholders can then be used as required.

To access the cupholders in the rear centre console (B), push and release the rear of the lid which will then fold forwards exposing the two cupholders. To close the lid, fold rearwards and push it shut to cover the two cupholders.

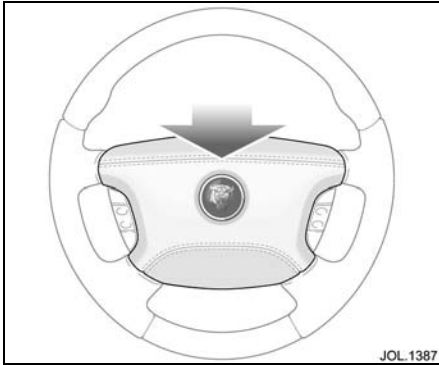

### Horn

The dual tone horn is operated by pressing the centre pad on the steering wheel.

The horn also operates as a warning horn if the vehicle alarm system is activated.

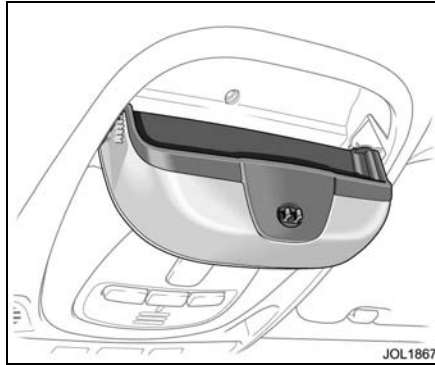

### Sunglasses Stowage

A compartment for stowing sunglasses or spectacles is located in the overhead console.

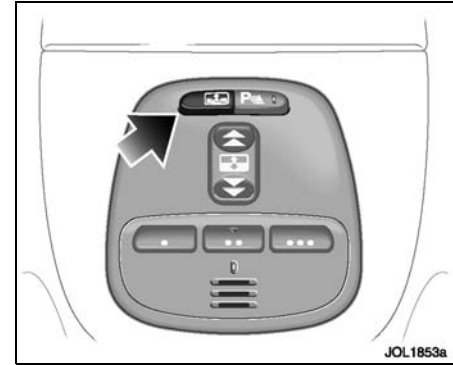

### Rear Sunblind

The electrically operated rear sunblind is fitted to the parcel shelf.

Push the switch to raise the sunblind.

To lower the sunblind, push the switch again.

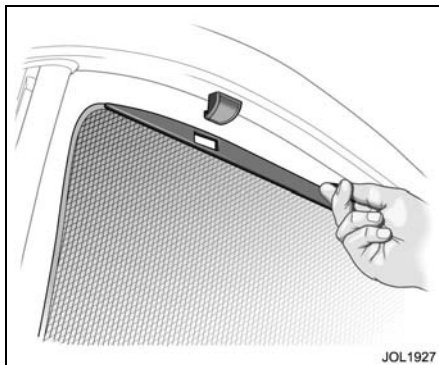

### Side Sunblinds

The rear door window sunblinds are manually operated by lifting the blind and securing it in the two clips provided. To lower the blind just unhook it from the clips and lower it gently back into the stowage.

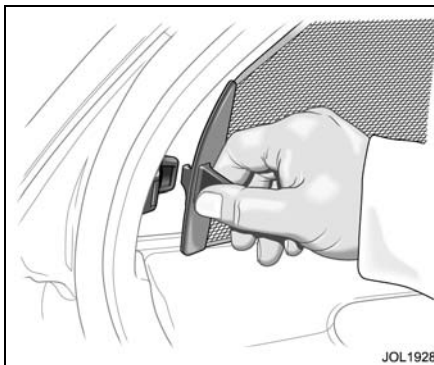

Quarter light blinds have a single securing clip. Pull the blind rearwards and locate it in the clip. To stow the blind, unhook it and gently let it return into the stowage.



#### **WARNING:**

**Take care when releasing the quarter light blind because it could strike your face if it slips from your hand.**

## Starting/Stopping the Vehicle

When the vehicle is stationary the automatic gear selector may be left in 'D', '2', '3', '4' or '5', unless the vehicle is to be parked. When stopping for traffic lights, junctions etc., either select 'P' or apply the parkbrake and select 'N'.

### Before Starting

Before starting the engine, new owners/drivers should familiarise themselves with the layout and operation of the controls and instruments.



#### WARNING:

**Before attempting to start the engine, check that the parkbrake is ON and that the gear selector lever is in position 'P' or 'N'.**

## To Start the Engine

The engine cannot be started until the gear selector is in 'N' or 'P'.

Insert the key into the ignition switch and turn clockwise to position 'II' to switch on the ignition.

When the key is turned to position 'III' the starter motor will turn the engine until:

- The key is released and automatically returns to position 'II'.
- The ignition switch is turned to '0' or 'I'.
- The gear selector is moved out of 'P' or 'N'.
- The engine starts.

If the engine fails to start, the key must be turned to position '0' before attempting to restart.

Do not use the starter continuously for longer than six seconds. Continued use of the starter will discharge the battery and may damage the starter mechanism.

Wait until the engine stops turning before re-using the starter.

When the engine starts, release the key.

The red charge indicator and the oil pressure warning lights in the instrument cluster should go out when the engine is running.

### If the engine fails to start

If an ignition key is placed in the ignition switch and turned to position 'II' and the alarm security light is flashing, it is possible that the engine will not start. In any event, please contact a Jaguar Dealer to investigate the cause of the light flashing.

It is possible that the fuel system inertia switch may have tripped, see page 6-3 for the resetting procedure.

If the engine persistently fails to start and flooding is suspected, depress the accelerator pedal fully, hold it in this position and turn the key to position 'III' for six seconds. Release the key, remove your foot from the accelerator pedal and then attempt to restart the engine.

**Note:** The engine cannot start whilst the pedal is fully depressed, it must be released to enable the engine to start.

If the engine still fails to start, switch the ignition OFF and contact a Jaguar Dealer.

## 4-44 On the Road

### To Stop the Engine and Lock the Steering Column

Turn the key from position 'II' to the 'lock' position 'O'. This turns off the ignition and stops the engine.

The steering column will be locked when the key is removed from the switch.

Leaving the key in position 'I' or 'II' will discharge the battery.

### Automatic Transmission

The 'J'-gate gear selector lever is designed to accommodate two different driving techniques as follows:

- Automatic selection – the right-hand side of the selector gate.
- Manual selection – the left-hand side of the selector gate to individually select 5th, 4th, 3rd, or 2nd gear.

### Gearshift Interlock

A brake pedal/gearshift interlock system is incorporated in the automatic gear selector mechanism.

To move the gear selector from Park:

1. Turn the ignition key to position 'II' or start the engine.
2. Press the brake pedal.

**Note:** Under the following conditions, the brake pedal must be released and re-applied before moving the gear selector from Park:

- The gear selector was moved into Park while the brake pedal was depressed or;
- The brake pedal was depressed while the ignition was switched ON.

In either case the letter 'P' for PARK on the gearshift will flash to indicate that the interlock is still active.

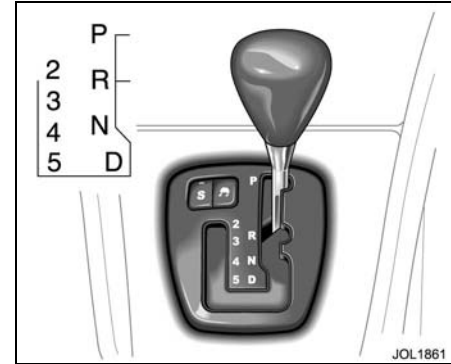

### Gear Selector Positions



**WARNING:**

**The parkbrake or brake pedal must be applied before selecting forward or reverse drive from a stationary position.**

**P = Park** – Use when parking. In this position the transmission is locked. Do not select if the vehicle is moving.

**N = Neutral** – Disconnects the driveline from the engine. Use the parkbrake when stopping temporarily.

**Note:**

1. After selecting forward or reverse drive ranges from Neutral or Park, wait briefly for the transmission to engage before accelerating.
2. When in Neutral or Park the engine can only be accelerated to 4500 rev/min.

**R** = Reverse – Do not select if the vehicle is moving forward.

The reversing lights come ON automatically when reverse gear is selected and the ignition switch is in position 'II'.

**D** = Drive – All six gears are changed automatically as required by the throttle position and road speed.

**2, 3, 4, 5** = If selected, the transmission operates automatically in second, third, fourth or fifth gear but will not engage gears higher than the one selected.

**Drive to fifth**

When driving in gear position 'D' with sixth gear engaged, the gear selector can be shifted sideways across the gate to '5'. Provided that the vehicle's speed is not too great, the transmission will shift down to fifth. Sixth gear will be inhibited until the gear selector is moved back to 'D'.

**Hill climbing and engine braking**

When driving on roads with long downhill gradients, selecting '3' or '2' (depending on road/traffic conditions) will give engine braking.

When the gear selector is moved from 'D', '5', '4' or '3' down to '2', downshift to second gear will only take place at appropriate road speeds.

**Reverse inhibit**

Reverse is inhibited when the vehicle is moving forward at speeds above 8 km/h (5 mph).

**Note:** Reverse inhibit will not function in limp-home mode.

**Kickdown**

Kickdown is operated when the pedal is pressed fully down, beyond the normal operating range and against a spring pressure, to provide maximum engine performance. Kickdown is used in circumstances where rapid acceleration is required, such as when overtaking.

Kickdown causes the transmission to change down to the lowest gear possible to achieve maximum acceleration.

The gear engaged depends on the road speed at the time of kickdown.

As well as shifting down, the gearshift points are extended to give greater performance. This mode is in effect for as long as the pedal is pressed fully down.

## 4-46 On the Road

### Limp-home mode

In the unlikely event of an electrical or mechanical failure, transmission operation will be impaired. The vehicle gear selector ranges 'P', 'R', 'N', 'D' can still be used to enable the vehicle to be driven to a safe area.

The driver should be aware that the vehicle's performance will be reduced and must take this into account when driving. In this event consult a Jaguar Dealer **immediately**.

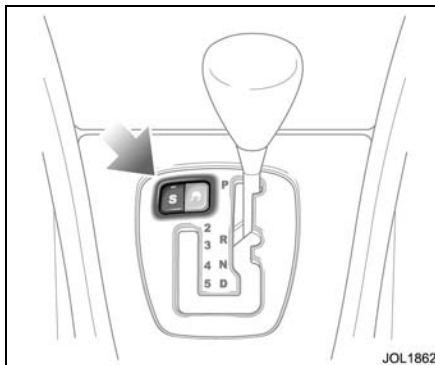

### Sport Mode

The switch marked 'S' on the 'J'-gate surround enables the driver to select either normal 'N' or sport 'S' modes.

When sport mode is selected the automatic transmission will operate normally, but the gearshift points are extended to make full use of the engine's power reserves.

To select 'Sport', press the switch. A red light within the switch is illuminated to indicate that sport mode has been selected.

To cancel 'Sport', press the switch again.

**Note:** Both sides of the 'J'-gate can be used irrespective of the transmission mode, e.g. with 'S' selected the transmission can be operated in full automatic or by manual selection.

In addition to the 'switched' transmission modes ('N' and 'S') the transmission control module will select shift patterns to suit specific conditions.

**Cruise control** – When cruise control is operating at set speed the transmission selects a shift pattern to suit cruise control operation.

**DSC** – When DSC is switched ON and the system is activated, the transmission selects a shift pattern to suit traction control conditions.

**Gradients** – When the vehicle is being driven on roads with uphill gradients, the transmission adapts the shift pattern to make better use of engine power and aid engine cooling.

**Note:** Under the conditions described, the relevant transmission mode will override the 'N' or 'S' modes selected by the driver. When such conditions no longer exist, the transmission will revert to the shift pattern previously selected by the driver, i.e. 'N' or 'S'.

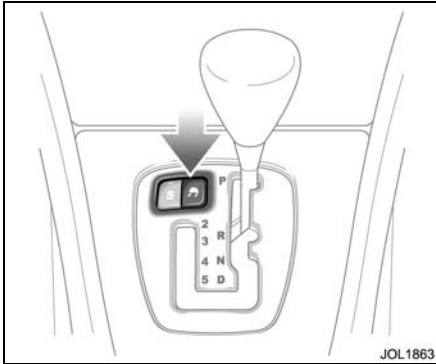

## Dynamic Stability Control (DSC)

Unless it has been switched off, dynamic stability control is operational whenever the engine is running. If the system is operating, the warning light in the instrument cluster will flash.

The DSC system controls the anti-lock braking system (ABS), traction control and yaw control of the vehicle.

Yaw control determines the vehicle's direction relative to the driver's inputs (sideslip and under/oversteer). It applies braking pressure to individual wheels if excessive variation is detected.

This ensures that the vehicle follows the driver's intended direction of travel.

Traction control will intervene to prevent wheel spin, by automatically reducing the power output from the engine and applying braking to individual wheels.

This improves acceleration, particularly on surfaces with uneven friction, for example, one wheel on ice and the other on tarmac.

ABS helps to prevent the road wheels from locking and skidding during emergency braking.

When the ABS system is operating, the warning light in the instrument cluster will flash.

The dynamic stability control system can be switched OFF by pressing the switch on the centre console switchpack. The warning light in the instrument cluster will remain on and a message will be shown to indicate that the system has been switched OFF. If the switch is pressed again the system will switch ON.

**Note:** If cruise control is engaged it will automatically disengage if stability control activates.

A system malfunction is indicated by the message:

**DSC NOT AVAILABLE**

Warning light: **Amber**

and the instrument cluster DSC warning light will be lit.

It is safe to drive the vehicle but the system may not activate under wheel spin or slide conditions. Report the fault to a Jaguar Dealer as soon as possible.



**WARNING:**

1. **The fact that the vehicle is fitted with dynamic stability control must never allow the driver to be tempted into taking risks which could affect his/her safety or that of other road users. In all cases it remains the driver's responsibility to drive safely according to the prevailing conditions.**
2. **It is recommended that when using snow chains, DSC should be switched OFF.**

### Anti-lock Braking System (ABS)

This system helps to prevent the road wheels from locking and skidding during emergency braking, assisting the driver to maintain full steering and directional stability.

The factor controlling ultimate stopping distance and cornering ability is tyre/road adhesion.



#### WARNING:

1. **The fact that a vehicle is fitted with ABS must never allow the driver to be tempted into taking risks which could affect his/her safety or that of other road users.**
2. **The addition of ABS cannot overcome the consequences of trying to stop in too short a distance or cornering at too high a speed, or the risk of aquaplaning.**

3. **The driver should always take road conditions into account. A slippery road surface always requires more braking distance for a given speed, even with ABS. A possible increase in stopping distance compared to locked wheels may occur during ABS operation on slushy snow, gravel, sand, or some heavily corrugated or ridged warning sections of road surfaces.**

ABS optimises tyre/road adhesion under maximum braking conditions though it cannot provide increased cornering ability. There is no need for special braking techniques, such as 'pumping' the brakes, to achieve optimum braking distances and control on poor or slippery road surfaces. Tyres must be in good condition to achieve maximum adhesion.

During normal braking the ABS will not be activated. However, if the braking force applied begins to exceed tyre/road adhesion the ABS will automatically activate, preventing the road wheels from locking.

In these circumstances a pulsating effect will be felt from the brake pedal indicating that the system is functioning. The pulsating effect is due to small fluctuations in pressure supplied to the brakes by the system to maintain full tyre/road adhesion.

Under severe braking on some road surfaces tyre noise may be apparent even though the wheels will at no time become locked.

### ABS Monitoring

The ABS control module monitors the ABS electrical system from ignition switch ON to ignition switch OFF.

Any malfunction will be indicated by the anti-lock warning light coming on.

Should a fault develop in the ABS system, the brake system will still operate conventionally and with the same standard of performance as vehicles not equipped with ABS.

**Caution: Consult a Jaguar Dealer immediately if the warning light comes on while driving, a system failure is indicated.**

### Advice on ABS Braking Techniques

For optimum ABS performance the instructions on braking techniques during ABS operation should be followed:

1. Do not release brake pressure when the pulsating effect is felt. Maintain a constant pressure until the manoeuvre is completed.
2. To familiarise yourself with the feel of the brake pedal during ABS braking, practise an emergency stop procedure, always making sure it is safe to do so. With the seat belts fitted to all occupants, drive the vehicle at 32 km/h (20 mph) and brake sharply.
3. ABS enables the driver to steer around obstacles during emergency braking. However, the consequences of turning sharply at high speed cannot be overcome by the ABS.
4. Do not attempt to 'pump' the brakes to avoid skidding as this can interfere with the ABS operation. The ABS will not allow the wheels to skid under normal road conditions.
5. The ABS will tend to keep the vehicle straight during braking. Because braking distances may increase under certain road conditions, it is necessary to plan and make turning manoeuvres as early as possible.

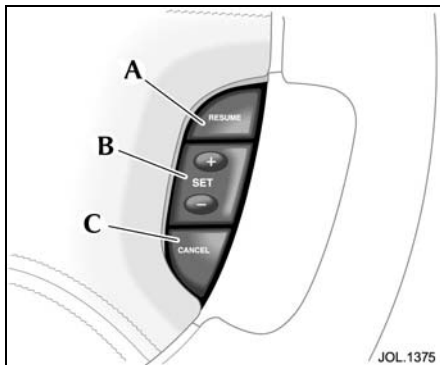

### Cruise (Speed) Control

The cruise (speed) control system, when fitted, can be used by the driver to maintain a selected vehicle speed above 28 km/h (17.5 mph) without the driver having to use the accelerator.

Switches on the steering wheel allow the driver manual control of the system. Brake operation also influences the cruise control system.

(A) – RESUME to resume the set speed retained in memory.

(B) – SET to set the speed or increase/decrease the set speed when the speed has been set.

(C) – CANCEL cancels cruise control but retains the set speed in memory.

### Setting the Vehicle Speed



#### WARNING:

**Only use cruise control when conditions are favourable, for example, straight, dry, open roads with light traffic.**

When you are travelling at the speed you require, which must be above 28 km/h (17.5 mph), press the SET button.

Cruise control will engage and maintain the set speed and you can remove your foot from the accelerator pedal.

**Note:** Cruise control will automatically disengage when the brake pedal is pressed or when the vehicle speed falls below 26 km/h (16 mph).

### Changing the Set Speed

There are three ways to change the set speed:

1. Accelerate or decelerate to the desired speed then press the SET (+) button.
2. Increase or decrease the speed by pressing and holding either SET (+) or (-) until the desired speed is obtained, then release the switch.
3. Increase or decrease the speed in steps of 2 km/h (1 mph) by briefly pressing either the SET (+) or (-) until the desired speed is obtained.

### Resuming the Set Speed

If the vehicle is accelerated above the set speed, then the set speed will be resumed when the accelerator pedal is released.

If CANCEL is pressed, or the brake pedal is pressed, the cruise control will disengage but the set speed memory will be retained. Press RESUME and the vehicle will return to the set speed.

**Note:** Cruise control will not resume at speeds below 28 km/h (17.5 mph).

RESUME will not operate if the ignition has been turned off.

**Caution:**

1. **RESUME should only be used if the driver is aware of the set speed and intends to return to it.**
2. **It is not recommended to resume set speed when a low gear is selected as excessive engine speeds will occur.**

**Cruise Control will Switch Off and Clear the Memory when:**

- The ignition is switched to position '0'.
- A fault occurs. The cruise control system will switch OFF and cannot be used until the fault is cleared.

**Cruise Control Automatic Switch Off**

Cruise control will switch off but the set speed will remain in the memory when:

- The CANCEL button is pressed.
- The brake pedal is pressed.
- The parkbrake is applied.
- Speed falls below 26 km/h (16 mph).
- Neutral, Park or Reverse gear positions are selected.
- DSC is operating.
- The difference between the actual and set speed is too great.
- The vehicle reaches a maximum speed of 230 km/h (144 mph).
- The accelerator pedal is used to accelerate beyond the set speed for too long a period.

### Adaptive Cruise Control (ACC) (where fitted)

The adaptive cruise control system is designed to aid the driver to maintain a gap from the vehicle ahead or a set road speed if there is no slower vehicle ahead. The system is intended to provide enhanced operation of the vehicle when following other vehicles which are in the same lane and travelling in the same direction.



**WARNING:**

**Adaptive cruise control is not a collision warning or avoidance system. Additionally, adaptive cruise control will not detect:**

1. Stationary or slow moving vehicles below 10 km/h (6 mph).
2. Pedestrians or objects in the roadway.
3. Oncoming vehicles in the same lane.



The adaptive cruise control system is based on the use of a radar sensor which projects a beam directly forward of the vehicle so as to detect objects ahead. The radar sensor is mounted behind a cover on the left-hand side of the lower cooling aperture, to provide a clear 'view' forward for the radar beam.

- Only use adaptive cruise control when conditions are favourable, that is, straight, dry, open roads with light traffic.
- Do not use in poor visibility, specifically fog, heavy rain, spray or snow.
- Do not use on icy or slippery roads.
- It is the driver's responsibility to stay alert, drive safely and be in control of the vehicle at all times.
- Keep the front of the vehicle free from dirt, metal badges or objects, including vehicle front protectors, which may prevent the sensor from operating.
- Do not use ACC when entering or leaving a motorway.

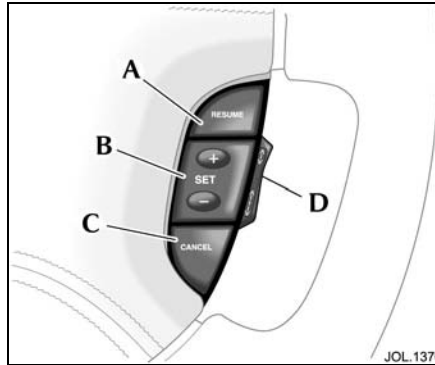

The system is operated by switches mounted on the steering wheel. The driver can also intervene at any time by use of the brake or accelerator pedals. The steering wheel switches operate as follows:

- (A) – RESUME to resume the set speed retained in memory.
- (B) – SET to set the speed or increase/decrease the set speed when the speed has been set.
- (C) – CANCEL cancels cruise control but retains the set speed in memory.
- (D) – Gap increase or decrease.

## Setting a speed

Accelerate as normal until the required speed is reached. Press the 'SET +' button briefly and the vehicle speed will then be stored in the memory and the system engaged. The set speed will be displayed on the message centre.



## Entering the follow mode



**WARNING:**

**When in follow mode the vehicle will not decelerate automatically to a stop, nor will the vehicle always decelerate quickly enough to avoid a collision without driver intervention.**

Once a set speed has been selected, the driver can release the accelerator and the set road speed will be maintained.

## 4-54 On the Road

---

When a vehicle ahead enters the same lane or a slower vehicle is ahead in the same lane, the vehicle speed will be adjusted automatically until the gap to the vehicle ahead corresponds to the preset gap. The vehicle is now in 'follow mode'.



The warning light in the instrument cluster will be illuminated,

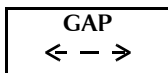

and the message centre will display the gap set.

The vehicle will then maintain the constant time gap to the vehicle ahead until:

- The vehicle ahead accelerates to a speed above the set speed.
- The vehicle ahead moves out of lane or out of view.
- The vehicle ahead slows so that 'low speed automatic switch off' occurs.
- A new gap distance is set.

If necessary, the vehicle brakes will be automatically applied to slow the vehicle to maintain the gap to the vehicle in front. The maximum braking which is applied by the ACC system is limited and can be overridden by the driver applying the brakes, if required.

**Note:** Driver braking will cancel adaptive cruise control.

If the ACC system predicts that its maximum braking level will not be sufficient, then an audible warning will sound while the ACC continues to brake. This is accompanied by a red warning light and 'DRIVER INTERVENE' will be displayed on the message centre. The driver should take IMMEDIATE action.

When in follow mode the vehicle will automatically return to the set speed when the road ahead is clear, for instance when:

- The vehicle in front accelerates or changes lane.
- The driver changes lane to either side or enters an exit lane.

The driver should intervene if appropriate.

### Low speed automatic switch off

If the speed of the vehicle decreases below 30 km/h (18 mph), the ACC system will be automatically switched OFF and the instrument cluster warning light will go out.

If the brakes were being applied by the ACC system, they will be slowly released.

This will be accompanied by an audible warning, a red warning light and 'DRIVER INTERVENE' will be displayed on the message centre. The driver must take control.

### Overriding the set speed/follow mode



**WARNING:**

**Whenever the driver is overriding the ACC by depressing the accelerator pedal, the ACC will not automatically apply the brakes to maintain separation from any vehicle ahead.**

The set speed and gap can be overridden by pressing the accelerator pedal when cruising at constant speed or in follow mode. If the vehicle is in follow mode, the instrument cluster warning light will go out when the ACC is overridden by the driver using the accelerator and 'CRUISE OVERRIDE' will be displayed on the message centre. When the accelerator is released the ACC function will operate again and vehicle speed will decrease to the set speed, or a lower speed if follow mode is active.

## Changing the set speed

There are three ways to change the set speed:

1. Accelerate or brake to the required speed and press the 'SET +' button.
2. Increase or decrease the speed by pressing and holding either the 'SET +' or '-' button until the required set speed is shown on the message centre. The vehicle speed will gradually change to the selected speed.
3. Increase or decrease the speed in steps of 2 km/h (1 mph) by briefly pressing the 'SET +' or '-' button.

ACC operates between approximately 34 km/h and 180 km/h (20 mph and 110 mph) dependent on the country specification.

Set speeds outside this range will not be captured.

The ACC may apply the brakes to slow down the vehicle to the new set speed. The new set speed will be displayed on the message centre for four seconds after it has been changed.

## Changing the gap

The gap from the vehicle ahead can be decreased or increased by pressing the gap setting rocker switch on the steering wheel. Four gaps are available and the selected gap setting will be displayed on the message centre when the rocker switch is pressed. After the ignition is switched ON the default gap will be automatically selected ready for ACC operation.

**Note:** It is the driver's responsibility to select a gap appropriate to the driving conditions, and in accordance with national driving regulations.

## ACC automatic switch off

Adaptive cruise control will disengage, but not clear the memory when:

- The CANCEL button is pressed.
- The brake pedal is pressed.
- The vehicle speed falls below 30 km/h (18 mph).
- Neutral, Park or Reverse gear positions are selected.
- The parkbrake is applied.
- DSC is activated.

Adaptive cruise control will disengage and clear the memory when:

- The ignition switch is set to position '0'.
- Maximum vehicle speed is reached.
- A fault occurs in the ACC system.

## Resuming the set speed/follow mode

By pressing the RESUME button after ACC has been cancelled, for example, after braking, the ACC will become active again provided that the set speed memory has not been erased. The set speed will be displayed for four seconds and the original set speed will be resumed, unless a vehicle ahead causes the follow mode to become active.

**Caution: 'RESUME' should only be used if the driver is aware of the set speed and intends to return to it.**



### Forward alert

Limited detection and warning of objects ahead is provided during ACC operation by the ACC 'DRIVER INTERVENE' warning.

The forward alert feature additionally provides warnings whilst ACC is not engaged; if an object is detected close ahead then a warning tone and message will be issued. The brakes will not be applied.

This additional feature may be switched on or off using the forward alert switch in the lower outboard knee bolster switchpack. When the indicator lamp in the switch is on, forward alert is active.

The sensitivity of the warning may be changed:

- Pressing the gap decrease button when ACC is disengaged displays and then decreases the sensitivity of the alert.
- Pressing the gap increase button displays and then increases the sensitivity of the alert.

Both of these are accompanied by the 'FORWARD ALERT ← — →' message on the message centre.

### ACC failure

If a fault occurs during operation of the system in cruise or follow modes, the ACC system will switch OFF and cannot be used until the fault is cleared. A red warning light and the message 'DRIVER INTERVENE' appear briefly, and are then replaced by an amber warning light and the message 'CRUISE NOT AVAILABLE'.

If failure of the ACC or any related system occurs at any other time an amber warning light will be displayed accompanied by the message 'CRUISE NOT AVAILABLE'. It will not be possible to activate the ACC system in any mode.

Accumulations of dirt, snow or ice on the sensor or cover may inhibit ACC operation. Fitting of a vehicle front protector or metallised badges may also affect ACC operation.

If this occurs in ACC cruise/follow mode, the red warning light is displayed, the audible alarm sounds and the message 'DRIVER INTERVENE' appears briefly. These warnings are then replaced by the amber warning light and the message 'ACC SENSOR BLOCKED' is displayed. The system is no longer active.

Clearing the obstruction allows the system to return to normal operation. If the obstruction is present when ACC is inactive, e.g. on initial starting or with the ACC system switched off, the amber warning light will be displayed with the message 'ACC SENSOR BLOCKED'.

Tyres other than those recommended may have different sizes. This can affect the correct operation of the ACC.

## Notes on using adaptive cruise control

1. Adaptive cruise control operates when the gear selector lever is in position '2', '3' '4' '5' or 'D'.
2. When engaged, the accelerator pedal rests in the raised position. Fully release the pedal to allow normal ACC operation.
3. When braking is applied by the ACC the brake pedal will move down and up as braking is applied or removed. The vehicle brake lights will be switched on while braking is applied.



### **WARNING:**

**The driver must not rest a foot under the brake pedal, as it may become trapped.**

## Driving with ACC active

The system acts by regulating the speed of the vehicle using engine control and the brakes. Gear changes may occur in response to deceleration or acceleration whilst in ACC.

ACC is not a collision avoidance system, however, during some situations the system may provide the driver with an indication that intervention is required.

An audible alarm will sound, accompanied by a red warning light and the message 'DRIVER INTERVENE' if the ACC detects:

- That using maximum ACC braking only is not sufficient.
- That the vehicle speed has decreased below the minimum for ACC operation.
- That a failure has occurred whilst the system is active.

## 4-58 On the Road

Detection issues can occur:

- When driving on a different line to the vehicle in front (A).
- With vehicles which edge into your lane which can only be detected once they have moved fully into your lane (B).
- When going into and coming out of a bend (C).

In these cases ACC may brake late or unexpectedly. The driver should stay alert and intervene if necessary.

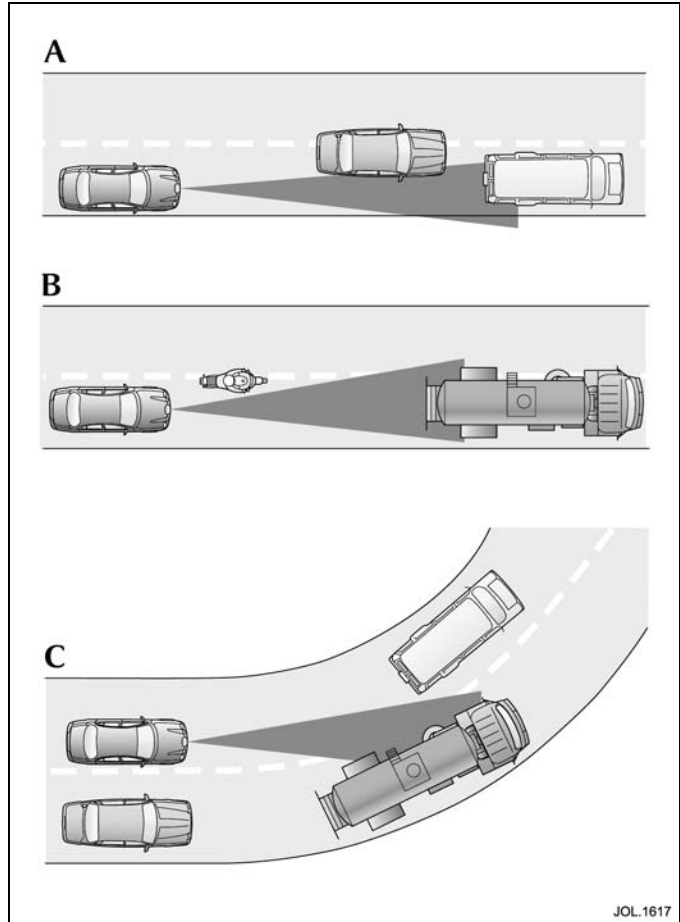

## Vehicle Suspension

This vehicle is fitted with a fully automatic air suspension system. It ensures that the vehicle is always at the correct ride height with varying load conditions, including luggage compartment load or when towing.

The system will automatically adjust the amount of air in the springs to level the vehicle. Air is supplied either from an air reservoir or a compressor.

The compressor will run periodically to refill the reservoir.

Changes in ambient temperature will also have an effect on vehicle height when the vehicle is parked.

### Caution:

1. **Do not overload the vehicle. Vehicle load weights are shown on page 8-4.**
2. **A slight air loss is expected over time causing the vehicle to lower, so do not store or place anything under the vehicle if it is to be left for an extended period.**

## Speed lowering

When driving at motorway speeds, the system will lower the vehicle to improve aerodynamics and vehicle stability. The suspension will automatically return the vehicle to the normal height when the vehicle slows.

Speed lowering is undesirable when towing. Only Jaguar approved towing equipment will not allow this feature.

## Warning messages

If the message 'VEHICLE TOO LOW' is displayed when the ignition is switched on, start the engine and wait for the suspension to raise. The vehicle should not be driven until the message is cleared.

If the message 'VEHICLE TOO LOW' is displayed when driving, restrict the vehicle speed and wait for the system to regain the correct height and the message will then clear. If the message is displayed frequently, inform your Dealer to have the system attended to.

If the message 'AIR SUSPENSION FAULT' is displayed at any time, drive with caution. Have the vehicle checked by a Dealer at the earliest opportunity.

**Note:** If your vehicle needs to be recovered by a roadside emergency service ensure that the vehicle is securely lashed by the wheels and NOT the body.

### General Driving Information



#### WARNING:

Ensure the parkbrake is on and the automatic gear selector is in position 'P' or 'N' before attempting to start the engine.

Before driving off, check the gauges and warning lights and messages. Take special note of any warning light that is on.

Seat belts are provided for your safety and it is unwise, and in certain countries illegal, to commence any journey, however short, without wearing them.

### Warming Up

Do not operate the engine at high speed when first started but allow time for the engine to warm up and the oil to circulate.

### Engine Braking on Downhill Gradients

When driving on mountain roads with long downhill gradients it is advisable to select a low gear.

### Running-in

Apart from a few precautionary recommendations, there are no strict 'running-in' procedures for this vehicle.

By observing the following advisory notes you will ensure maximum engine, transmission and brake life for your vehicle:

1. Allow the engine to warm up thoroughly before operating at engine speeds over 3500 rev/min.
2. Vary the speed frequently.
3. From 1500 kilometres (940 miles) onwards, gradually increase performance of the vehicle up to the permitted maximum speed, where road conditions permit.

### Running-in for brakes

To ensure that the brake pads can 'bed-in' evenly and reach their optimum wear and performance condition, usually within 480 kilometres (300 miles), the following points are recommended.

1. Where possible, avoid heavy braking or rough usage of the brakes as this can result in damage being caused to the brake pads and discs.
2. Avoid prolonged use of the brakes, for example, when descending severe gradients.
3. Frequent light application of the brakes is desirable. This helps to fully 'bed-in' the brake pads before the normal running-in period is completed and the vehicle is operated at high speeds, when maximum brake efficiency will be required.

The above equally applies when new discs or pads have been fitted.

## Use of Headlights in Daylight

When visibility is poor the headlights with dipped beam setting should be switched on so that the vehicle may be seen more easily by other road users.

The instrument illumination dimmer control adjusts the brightness of the panel lighting.

## Engine Oil Consumption

A certain amount of oil consumption is normal. The rate of consumption will depend on the following:

- The quality and viscosity of the oil.
- The amount of oxidation and dilution of the oil.
- Climatic conditions.
- The speed at which the engine is being operated.
- Road conditions.

Drivers should expect above normal consumption when the engine is new, and after running-in if high speeds are sustained.

## Parking the Vehicle

When leaving the vehicle, remember the following:

- Whenever the vehicle is being parked, apply the parkbrake and move the gear selector to Park 'P'.
- Do not leave children or pets in the vehicle unattended.
- Do not leave luggage or valuables on view. Always take your valuables with you or lock them in the luggage compartment.
- Remove the ignition key and spare keys, even when the vehicle is in your garage.
- When the vehicle is unoccupied, close all windows and lock all doors securely.
- Park the vehicle where it can be seen. At night, park in a well-lit area.
- When leaving the vehicle unattended, for maximum security ensure that the doors are double-locked (where fitted).

- Ensure that the keys and the key transmitters are removed from the vehicle before locking the doors, and that all doors, the luggage compartment and the bonnet are closed.

## 4-62 On the Road

---

### Winter Driving

#### Freeing a frozen door lock

**Caution: Do not apply a proprietary lock de-icer through the keyhole.**

Should the lock become frozen, warm the end of the key before use.

#### Windscreen wiper blades

Before driving away, clear any ice from the windscreen and check that the wiper blades are free. Switching on the heated screen will accelerate this process. The heated wiper park, if fitted, will come on automatically.

#### Frost precautions

The correct concentration of coolant must be maintained at all times when 'topping up' or 'refilling' the cooling system.

### Touring

#### Foreign travel

Before planning foreign travel, check with a motoring organisation to ensure that your vehicle will comply with legal requirements of the countries you intend to visit.

International motoring organisations are helpful for all aspects of long distance touring advice.

In some countries it is a legal requirement to carry spare vehicle bulbs.

#### First aid kit

A first aid kit is compulsory equipment in certain countries. Your Jaguar Dealer can supply a first aid kit.

#### Fire extinguishers

Many countries make it compulsory to carry a fire extinguisher. Your Jaguar Dealer can supply and fit one.

#### Petroleum spirit in containers

Some countries forbid the carrying of petrol in containers, as do most ferry and hovercraft operators.

#### Cellular radio telephones

Ask your motoring organisation about the use of cellular radio telephones before travelling abroad, as some countries exercise controls on the importation and use of such equipment.

#### Roof-rack

Only the Jaguar approved roof-rack should be used.

The maximum load, including the weight of the rack, must not exceed the load rating indicated on the roof-rack bars and **must** be deducted from the vehicle maximum luggage load.

Loads on the roof-rack may affect vehicle handling, especially in crosswinds or when cornering.

### Jaguar warning triangle

A warning triangle to give traffic advanced notice of a disabled vehicle is compulsory in many countries.

A triangle, designed to international standards, is fitted as standard equipment in certain countries.

Hazard warning lights must be used with the warning triangle.

The warning triangle, with its stand legs folded flat, is mounted on the inside of the luggage compartment lid.

In an emergency, remove the triangle and unfold its stand legs. Place the triangle in the road in accordance with local traffic regulations to give oncoming traffic warning of an immobilised vehicle.

### Towing a Caravan or Trailer

Your Jaguar Dealer, and the main motoring and caravanning organisations can advise you on towing, towing weight capacities and about regulations that apply in other countries.

The following are important points of safety, stability and comfort upon which further advice should be sought:

- Maximum braked towing weight is permissible, provided long periods of uphill driving on gradients over 8% are not undertaken.
- In high altitude mountainous regions, the thinner atmosphere can reduce engine performance. Above 1000 metres (3280 feet) the stipulated maximum permitted gross train weight must be reduced by 10% for every 1000 metres (3280 feet) in altitude.
- The kerbside weight of the vehicle can be found on page 8-4.
- When towing at the maximum permissible rear axle load keep within legal towing speeds.

- Tyres must be inflated to the normal (higher) pressures shown on the tyre pressure label on the fuel filler flap.
- The recommended maximum tow-ball nose weight is shown on page 8-5. Having a lower nose weight or exceeding the maximum nose weight limit may impair the vehicle's handling.
- When towing, the nose weight of the caravan or trailer and the tow-bar assembly must be deducted from the permissible maximum load, see page 8-5.
- Avoid heavy braking. As the overrun brake on the caravan or trailer is not connected to the ABS, heavy caravan or trailer braking could critically affect the stability of the outfit as a whole.
- Ensure that the towing vehicle's engine, transmission, suspension, brakes and tyres are fully efficient and regularly serviced. Similarly check the wheels, tyres, brakes and wheel bearings of the caravan or trailer.

## 4-64 On the Road

---

### Caution:

1. When not in use, it is recommended that the removable tow-ball is either securely stowed in the luggage compartment or, preferably, not in the vehicle. Do not leave it loose in the vehicle.
2. It is essential that only a Jaguar tow-bar and Jaguar electrical tow-bar kit are supplied and fitted by a Jaguar Dealer. This is particularly important with this vehicle having air suspension. If unapproved towing equipment is used whilst towing, the air suspension speed lowering function will not be inhibited. This may result in a change in trailer weight distribution and attitude.

## Fuel and Refuelling

Before refuelling, switch off the ignition and remove the key.

**Note:** Do not leave the ignition key in the vehicle; vehicles have been stolen from garage service/filling stations whilst the driver is absent from the vehicle. It is recommended that the vehicle is locked, if left unattended.

**Caution:** No additives of any kind (fuel or oil) must be put into the fuel tank. Additives could reduce engine life or affect exhaust emissions.



### WARNING:

1. Fuel vapour is highly flammable and in confined spaces is explosive and toxic. In the event of inadvertent spillage, and before refuelling, always switch OFF the engine. Do not use exposed flame or light. Do not smoke. Do not inhale fumes.
2. Do not fill the tank so that fuel is visible in the fuel filler intake tube. This could cause spillage and danger from exposed fuel.

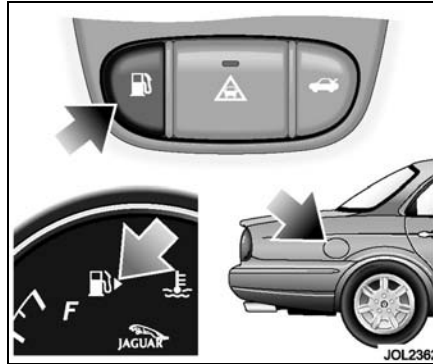

## Fuel Tank Filling

**Caution:** Your vehicle is fitted with catalytic converters and must only be filled with 'Unleaded Fuel'.

The fuel filler flap release switch is located in the knee bolster switchpack below the fascia. The filler flap is on the right-hand side of the vehicle.

A small arrow is shown on the fuel gauge as a reminder on which side of the vehicle the fuel filler flap is located.

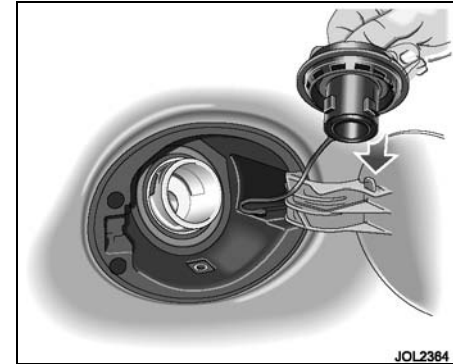

Open the fuel filler flap and turn the filler cap anti-clockwise, an 1/8 turn, and remove the cap from the filler neck. The cap is held by a retaining strap and can be stowed over the hook on the flap to allow easy access to fill the tank.

A warning label on the inside of the fuel filler flap advises type/grade of fuel.

## 4-66 On the Road

---

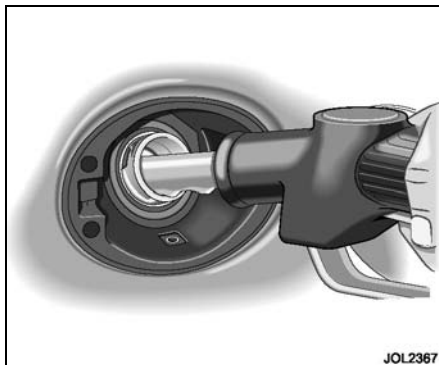

When filling, the dispenser nozzle must be inserted into the filler neck sufficiently to open the trap door for fuel to flow into the fuel tank. For quickness and to completely fill the tank, ensure that the fuel nozzle rests on the filler neck as shown. Fill the tank until the filler nozzle automatically shuts off. Filling beyond this point could result in fuel spillage.

After refuelling, twist the filler cap clockwise until it clicks and close the flap, which automatically locks shut.

The continuous use of high quality fuel makes the need for additional additives unnecessary.

This will help to protect the engine components against corrosion, carbon deposit formation and prevent the fuel injection system from clogging.

If in doubt your local Jaguar Dealer will advise on which fuel must be used in your vehicle.

### **Fuel requirements**

The filler neck of the fuel tank is a small diameter to suit the unleaded fuel pump nozzle and will prevent the larger diameter leaded fuel nozzle from entering the filler neck.

Not all countries have a small diameter nozzle, for example, Japan, so care must be taken to only fill the tank with unleaded fuel.

**Fuel capacity**

Avoid the risk of running out of fuel and never intentionally drive the car when the fuel gauge indicates that the tank is empty. When refuelling your vehicle after the fuel gauge reads empty, you may not be able to add the fuel quantity shown below to the tank as there will be a small reserve remaining in the tank.

	<b>Normally Aspirated</b>	<b>Supercharged</b>
Tank capacity	85 litres 18.7 gallons	84.5 litres 18.6 gallons
Fill capacity (when fuel gauge indicates empty)	79 litres 17.4 gallons	77 litres 16.9 gallons
Reserve capacity (when fuel gauge indicates empty)	5.8 litres 1.3 gallons	7.5 litres 1.6 gallons

**Fuel Economy**

The following tips not only lead to greater fuel economy but also reduce air pollution causing less environmental damage:

- Try to avoid using the car for short journeys – this will lead to greater fuel economy and reduce wear on the engine.
- Plan ahead – choose uncongested routes, combine car trips and share cars where possible.
- Drive off as soon as possible after starting a cold engine – do not leave the engine idling until it has warmed up.
- Drive smoothly and efficiently – harsh acceleration and heavy braking have a significant effect on fuel consumption – driving more smoothly saves fuel.
- Slow down – driving at high speeds significantly increases fuel consumption.
- Switch off – sitting stationary is zero miles per gallon, switch off the engine when it is safe to do so.
- Unnecessary weight – do not carry unnecessary weight and remove roof-racks when not in use.
- Regular servicing keeps the engine at best efficiency.
- Ensure that tyres are inflated to the correct pressure for the journey.
- Use air conditioning and all vehicle electrical devices sparingly – all increase fuel consumption.
- Check your fuel consumption – it will help you get the most from your car and any significant change in consumption may indicate a vehicle fault.

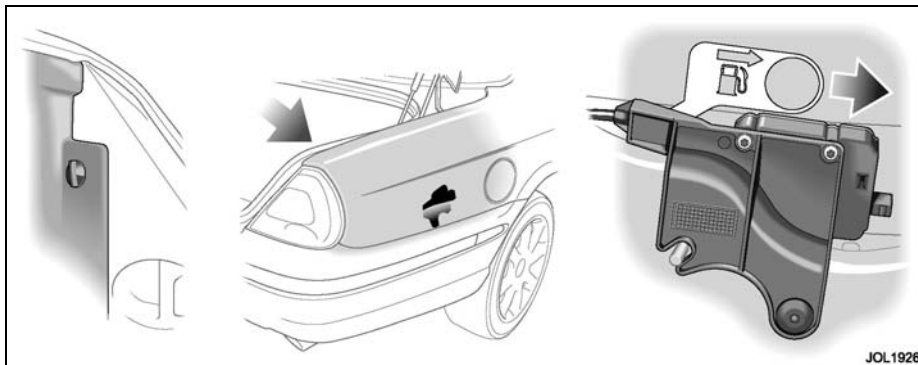

### Fuel filler flap manual release

If the fuel filler flap fails to release it can be manually unlocked as follows:

1. In the luggage compartment, remove the carpet from the right-hand side by turning the carpet securing screws anti-clockwise, then gently pull the carpet down.
2. Locate the fuel flap release mechanism and pull the knob rearwards. This will release the flap to gain access to the filler cap and enable the vehicle to be refuelled.
3. Report the fault to a Jaguar Dealer.

### Unleaded fuel

All vehicles are fitted with a catalytic system and can only use unleaded fuel.

Unleaded fuel must be used for the emission control system to operate properly. Its use will also reduce spark plug fouling, exhaust system corrosion and engine oil deterioration.

The preferred fuel should have an octane rating of at least 95 RON (Research Octane Number).

'Super Green' Plus 98 RON unleaded fuel (where available) may be used as an alternative to the standard 95 RON unleaded fuel.

Some countries have only 91 RON fuel available. The vehicles in these countries are specially calibrated to use this fuel.

Using unleaded fuel with an octane rating lower than recommended can cause persistent, heavy 'spark knock' (a metallic rapping noise). If severe, this can lead to engine damage.

If a heavy 'spark knock' is detected even when using fuel of the recommended octane rating, or if you hear steady 'spark knock' while holding a steady speed on level roads consult a Jaguar Dealer to have the problem corrected. Failure to do so is misuse of the vehicle, for which Jaguar Cars Limited is not responsible. However, occasional light 'spark knock' for a short time while accelerating or driving up hill, may occur.

## Fuels containing alcohol

**Caution:** Take care not to spill fuel during refuelling. Fuel containing alcohol can cause paint damage, which may not be covered under the warranty.

Some fuel suppliers sell fuel containing alcohol without advertising its presence. Where uncertainty exists check with the service station operator.

**Note:** Some difficulty in starting may be encountered when using alcohol blended fuel.

## Ethanol

Fuels containing up to 10 per cent ethanol (grain alcohol) may be used. Ensure the fuel has octane ratings no lower than those recommended for unleaded fuel. Most drivers will not notice any operating difference with fuel containing ethanol. If a difference is detected, the use of conventional unleaded fuel should be resumed.

## Methanol

Some fuels contain methanol (methyl or wood alcohol). If you use fuels containing methanol the fuels must also contain co-solvents and corrosion inhibitors for methanol. Also, do not use fuels that contain more than three per cent methanol even if they contain co-solvents and corrosion inhibitors. Fuel system damage or vehicle performance problems resulting from the use of such fuels is not the responsibility of Jaguar Cars Limited, and may not be covered under the warranty.

## Methyl Tertiary Butyl Ether (MTBE)

Unleaded fuel containing an oxygenate known as MTBE can be used provided the ratio of MTBE to conventional fuel does not exceed 15 per cent.

MTBE is an ether based compound, derived from petroleum, which has been specified by several refiners as the substance to enhance the octane rating of fuel.

## Catalytic Converters

A few precautions on the use of vehicles fitted with catalytic converters are necessary. These are:

1. In order to maintain the efficiency of the emission control system it is essential that unleaded fuel is used. Use of leaded fuel will seriously damage the catalytic converters.
2. Heavy impact on the converter casings must be avoided.
3. The engine settings must not be altered; they have been established to ensure that the vehicle will comply with stringent exhaust emission regulations. Incorrect engine settings could cause unusually high catalytic converter temperatures and thus result in damage to the converter and vehicle. If adjustment to the settings is considered necessary, this should be performed by a Jaguar Dealer.

## 4-70 On the Road

---

4. A correctly tuned engine optimises exhaust emissions, performance and fuel economy and it is recommended that the vehicle is regularly maintained.
5. Do not continue to operate the vehicle if any engine malfunction is evident; malfunctions should be rectified immediately. For instance, misfire, loss of engine performance, excessive oil consumption or engine run-on may lead to unusually high catalytic converter temperatures and may result in damage to the converters and vehicle.
6. The use of catalytic converters increases exhaust system temperatures, therefore, do not operate or park the vehicle in areas where combustible materials such as dry grass or leaves may come into contact with the exhaust system.
7. Do not run the engine with either a spark plug lead disconnected or a spark plug removed. Do not use any device that requires an insert into a spark plug hole in order to generate air pressure e.g. tyre pump, paint spray attachment etc., as this could also result in catalytic converter damage.
8. The vehicle is designed for normal road use. Below are examples of abuse which could damage the catalytic converters and vehicle. These may lead to a dangerous condition due to excessively high catalytic converter temperatures.
  - Competition or off-road use.
  - Excessive engine speed.
  - Overloading the vehicle.
  - Switching off the engine whilst in gear.