

# Supercharger Cooling System Draining, Filling and Bleeding

1.



**WARNING:** Never remove the coolant pressure cap under any circumstances while the engine is operating. Failure to follow this instruction may result in personal injury.



**WARNING:** To avoid having scalding hot coolant or steam blow out of the cooling system, use extreme care when removing the coolant pressure cap from a hot cooling system. Wait until the engine has cooled, then wrap a thick cloth around the coolant pressure cap and turn it slowly until the pressure begins to release. Step back while the pressure is released from the system. When certain all the pressure has been released (still with a cloth) turn and remove the coolant pressure cap from the coolant expansion tank. Failure to follow these instructions may result in personal injury.



**WARNING:** To avoid the possibility of personal injury, do not operate the engine with the hood open until the fan blades have been examined for cracks and separation. Failure to follow this instruction may result in personal injury.



**WARNING:** Remove fuse 14 from the engine compartment fuse box prior to performing any under hood service in the area of the cooling fan when the engine is hot, since the cooling fan motor could operate if the engine has been switched OFF. Failure to follow this instruction may result in personal injury.



**CAUTION:** The engine cooling system must be maintained with the correct concentration and type of anti-freeze solution to prevent corrosion and frost damage. Failure to follow this instruction may result in damage to the engine.



**CAUTION:** Never remove the coolant pressure cap under any circumstances while the engine is operating. Failure to follow this instruction may result in damage to the engine.

Release the cooling system pressure.

- Remove the coolant expansion tank pressure cap.

2. Remove the radiator splash shield. <<501-02>>

3. Detach the electrical connectors.

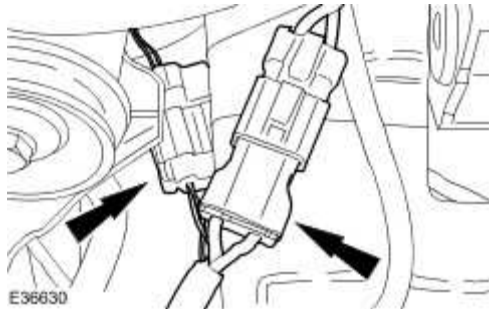

4. Remove the radiator lower cowl.



5. Remove the radiator drain plug.

- Drain the coolant into a suitable container.

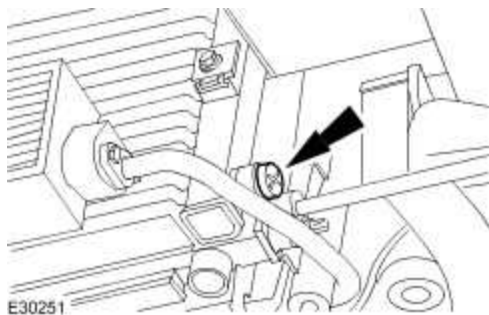

6.



**CAUTION: Do not over tighten the radiator drain plug. Failure to follow this instruction may cause damage to the vehicle.**

Install the radiator drain plug when all coolant has drained.

- Tighten to 1 Nm.
- Remove the container.

- Clean off any spillages.

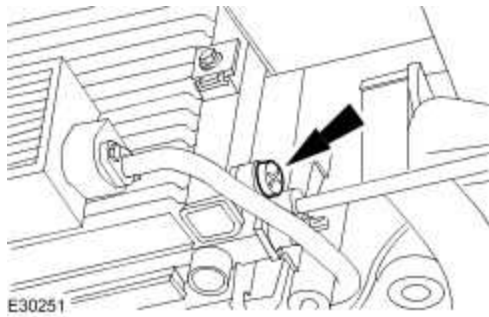

7. Install the radiator lower cowl.



8. Connect the electrical connectors.

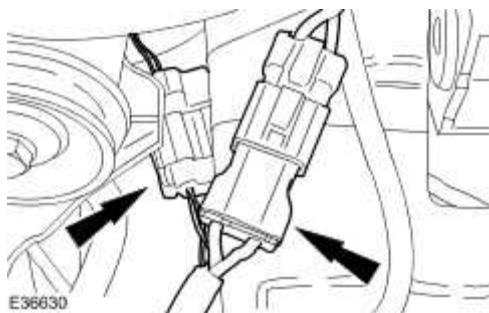

9. Install the radiator splash shield. <<501-02>>

10. Remove the coolant expansion tank bleed screw.

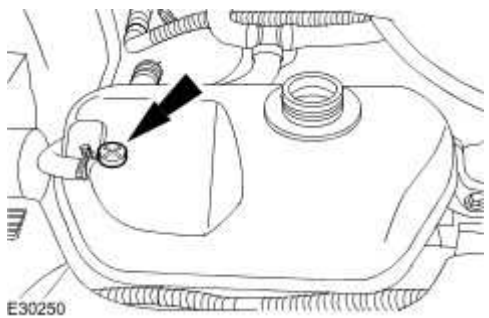

11.



**CAUTION:** The supercharger cooling system must be maintained with the correct concentration and type of coolant solution to prevent corrosion and frost damage. Failure to follow this instruction may result in damage to the vehicle.

Fill the cooling system up to the MAX mark on the coolant expansion tank using a fifty percent mixture of Jaguar Premium Cooling System Fluid or equivalent, meeting Jaguar specification WSS M97B44-D and fifty percent water.

12.



**CAUTION:** Do not over tighten the coolant expansion tank bleed screw. Failure to follow this instruction may cause damage to the vehicle

Install the coolant expansion tank bleed screw.

- Tighten to 1 Nm.

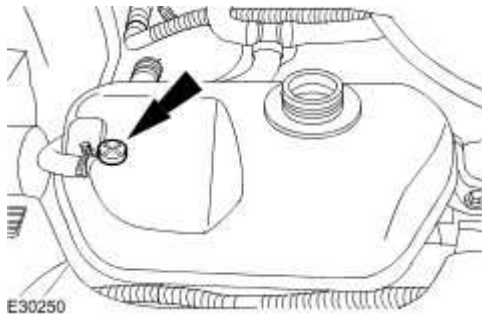

13. Install the coolant expansion tank pressure cap.

14. Remove the engine cover.

15. Remove the supercharger coolant filler plug.

- Remove and discard the sealing washer.

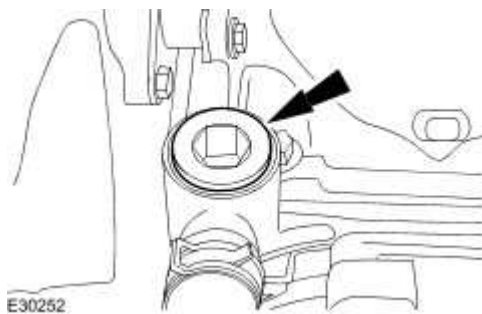

16. **NOTE:**

Place a suitable cloth around supercharger fill port.

Top up the coolant through the supercharger fill port.

17.



**CAUTION: Coolant may spill from supercharger fill port when ignition switched on.**

Switch ignition on.

18. **NOTE:**

Do not allow the supercharger water pump to run dry for more than one minute. Failure to follow this instruction may result in damage to the vehicle.

Allow the supercharger pump to run and top up the coolant through supercharger fill port.

19. Switch the ignition off.

20. Install the supercharger coolant fill plug.

- Install a new sealing washer.
- Tighten to 45 Nm.
- Clean off any spillages.

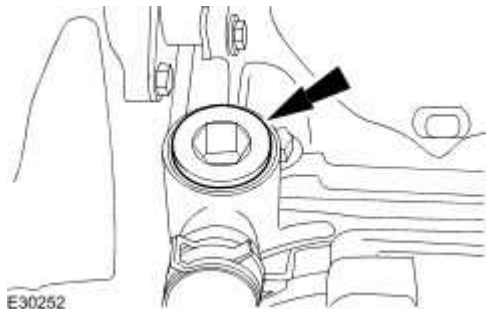

21. Install the engine cover.

22.



**CAUTION: Do not RUN the engine with the coolant expansion tank pressure cap removed. Failure to follow this instruction may cause damage to the vehicle**

START and RUN the engine.

23. SET the heating system to MAX heat, the blower motor to MAX speed and the air

distribution to instrument panel registers.

24.



**CAUTION: Observe the engine temperature gauge. If the engine starts to over-heat switch off immediately and allow to cool. Failure to follow this instruction may cause damage to the vehicle.**

Allow the engine to RUN until hot air is emitted from the instrument panel registers, while observing the engine temperature gauge.

25. Switch off the engine.

26. Allow the engine to cool.

27. Release the cooling system pressure.

- Remove the coolant expansion tank pressure cap.

28. Fill the cooling system up to the MAX mark on the coolant expansion tank using a fifty percent mixture of Jaguar Premium Cooling System Fluid or equivalent, meeting Jaguar specification WSS M97B44-D and fifty percent water.

29. Install the coolant expansion tank pressure cap.