

# JAGUAR X300 QUICK NOTES

JOE BARRY 816- 807- 3946 10622 N.Charlotte KCMO 64155

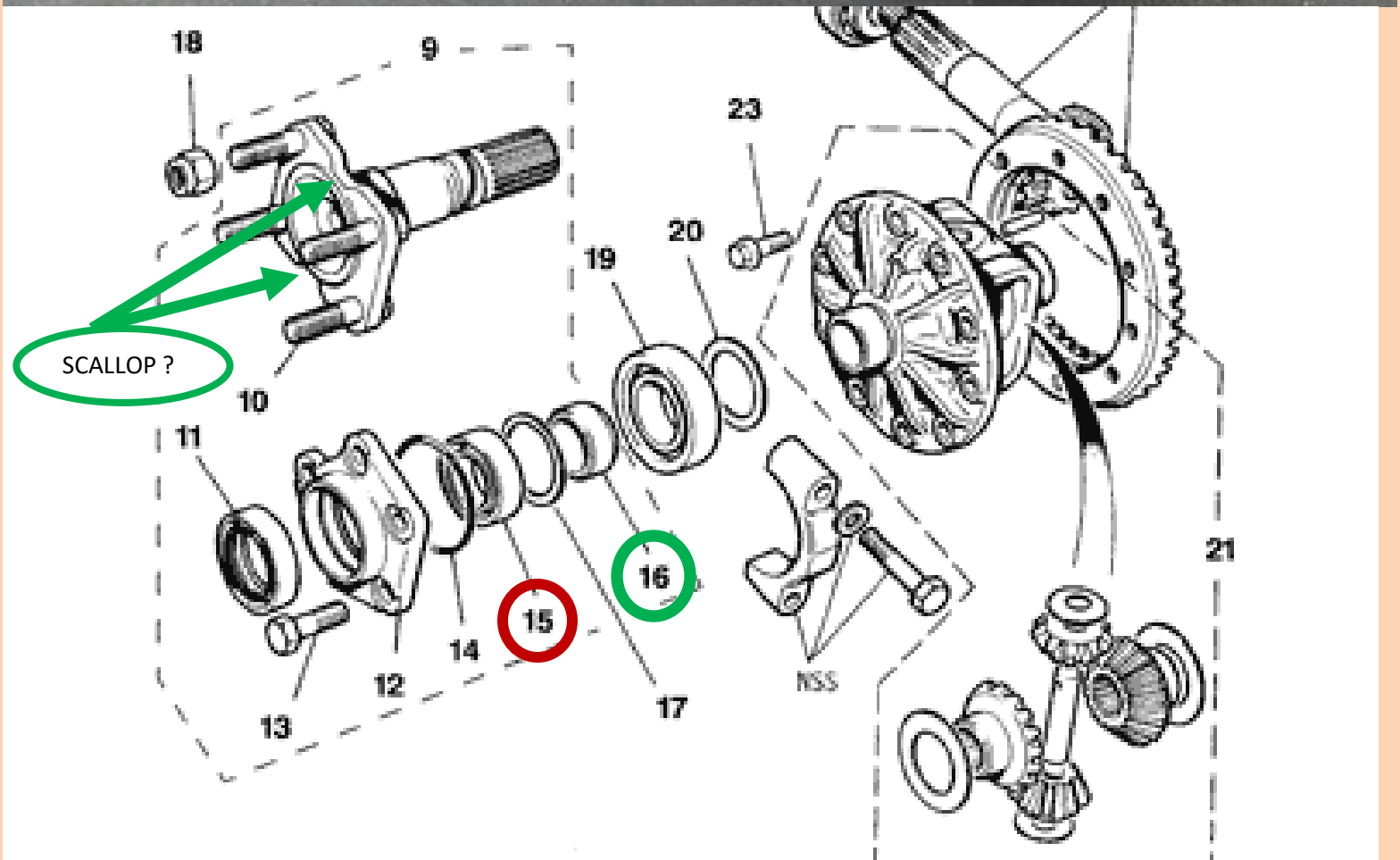

CHECK OUT THE GRILL  
OH BABY OH BABY OH BABY



SCALLOP ?

NSS

No.	Description	Price	Quantity
1	+ Pinion locknut		
2	+ Collapsible spacer		
3	+ Pinion bearing		
4	+ Taper roller bearing		
5	+ Xylan coated washer		
6	+ Pinion oil seal		
7	+ Companion flange		
8	+ Pinion head shim kit		
9	+ Drive shaft		
10	+ .Stud		
11	+ .Output shaft oil seal		

OFFICAL  
JAGUAR #'s

No.	Description	Price	Quantity	
	JLM12138	£45.38	<input type="text" value="1"/>	<input type="text" value="1"/> ADD
12	+ .Retaining plate			
13	+ .Torx head bolt			
14	+ .O-ring			
	JLV621	£5.51	<input type="text" value="5"/>	<input type="text" value="5"/> ADD
15	+ .Ball bearing			
	JLM1527		<input type="text" value="1"/>	<input type="text" value="1"/> ADD
16	+ .Shaft bearing retaining collar			
	JLV615	£41.37	<input type="text" value="1"/>	<input type="text" value="1"/> ADD
17	+ Drive shaft shim kit			
18	+ Nut			
19	+ Roller bearing			
20	+ Differential bearing shim kit			
21	+ Differential			

37.15 us



15

11

LEFT

16

14

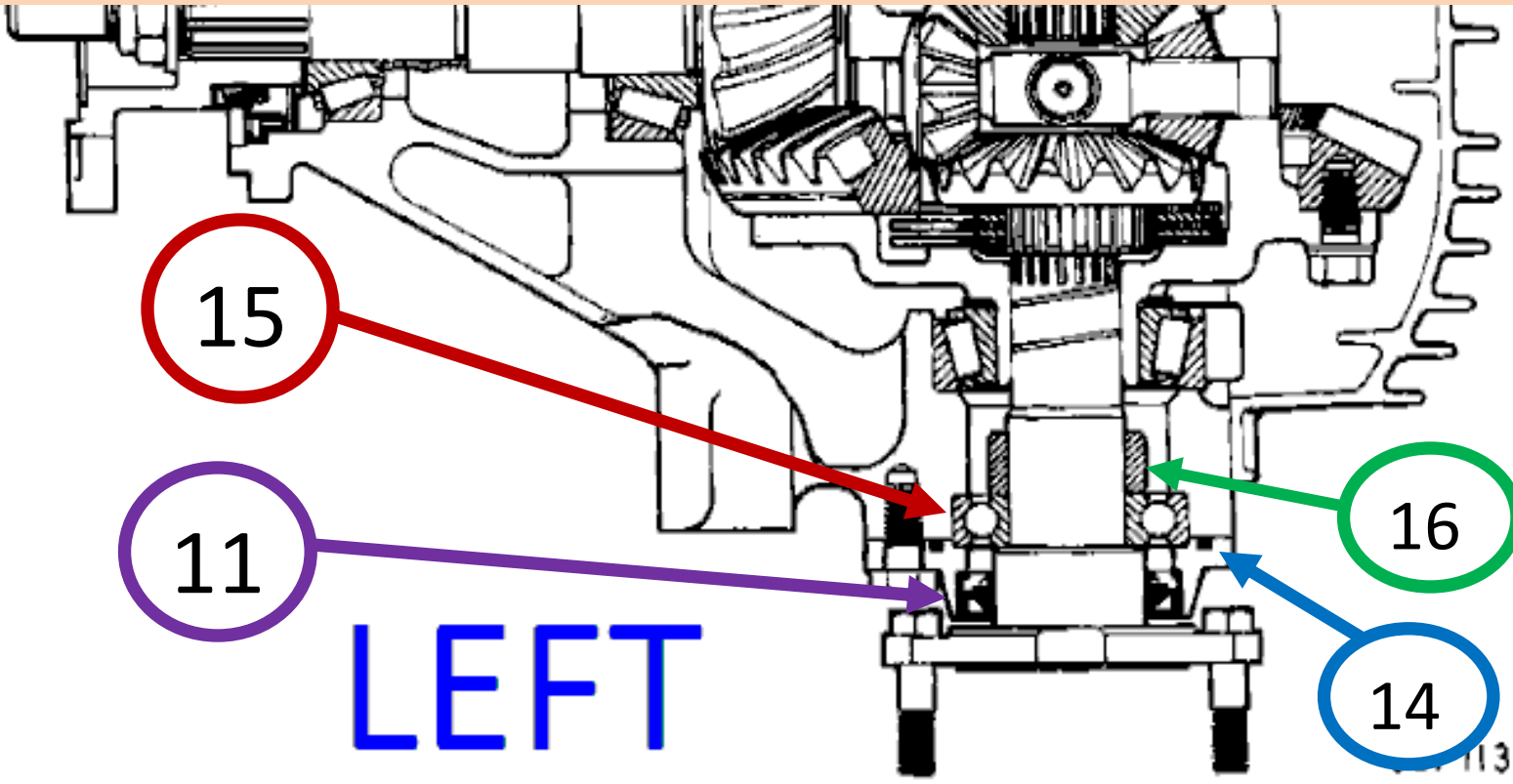

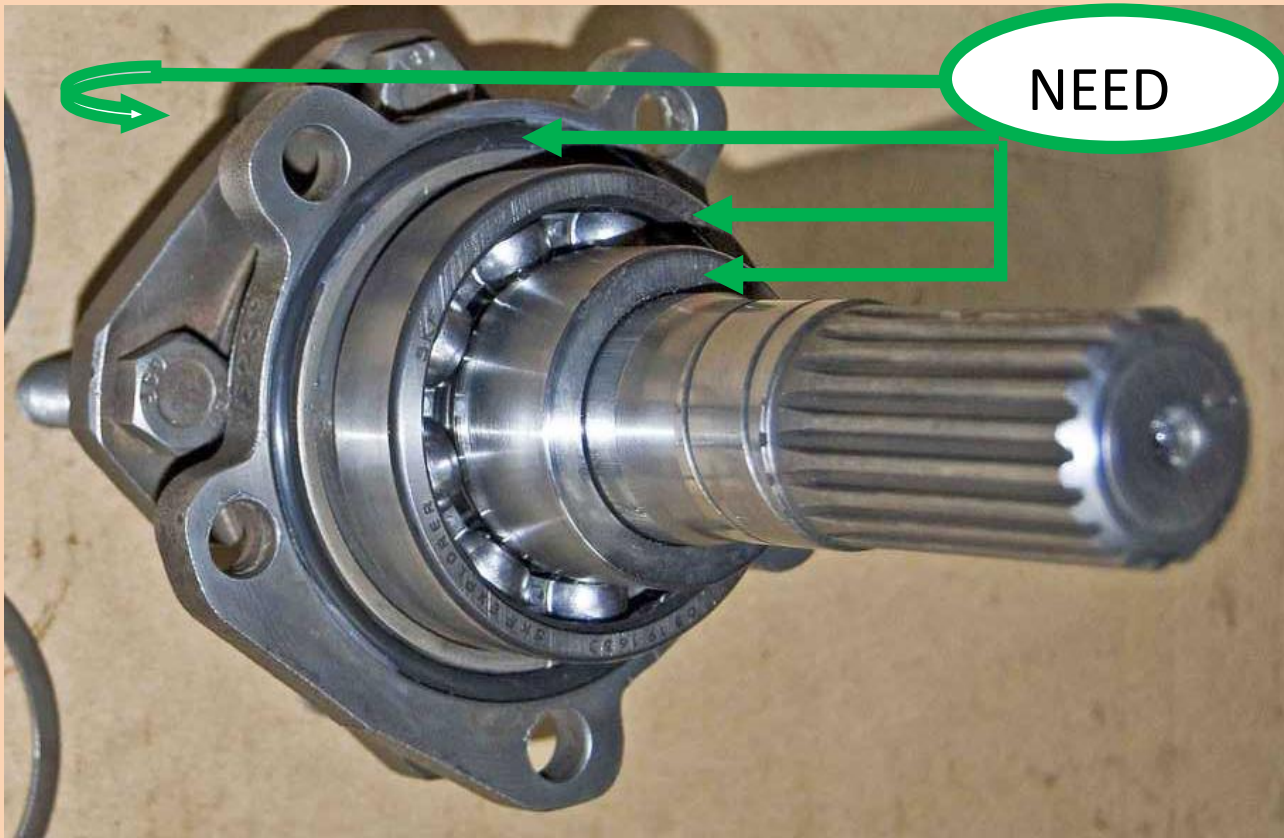

# JLM12138



JLM621



JLM11527



JLM615

# What's the difference between Torx® and Torx Plus® bits?

Torx Plus® bits and fasteners feature a greater engagement area for higher torque transfer and reduced camout when driving Torx Plus® fasteners. They can provide up to 100% **TORXplus®** more drive cycles.

Torx Plus® bits are not compatible with standard Torx® fasteners.



Torx Plus® is a trademark of the Camcar Division of Textron. Torx Plus® Tamper Resistant Bits are available on a limited basis. Please contact your Area Distributor or Representative for more details.



TORX



TORX-PLUS







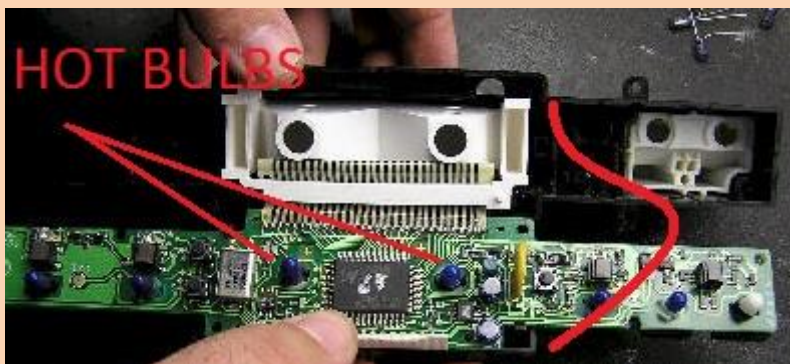

speakerworks.com

5 1/4 inch Speaker Repair Kit **Angled** or Flat Attach with 1 Foam Surround - **SWK525**

Price: \$8.95 **Sale Price: \$5.95** You save \$3.00!

Nitrile Rubber Adhesive (Best For Plastic Speaker Cones) Add \$0.99

for Outdoor / Car application



JAGUAR / APLINE AJ9500R



RADIO SIDE Looking Aft

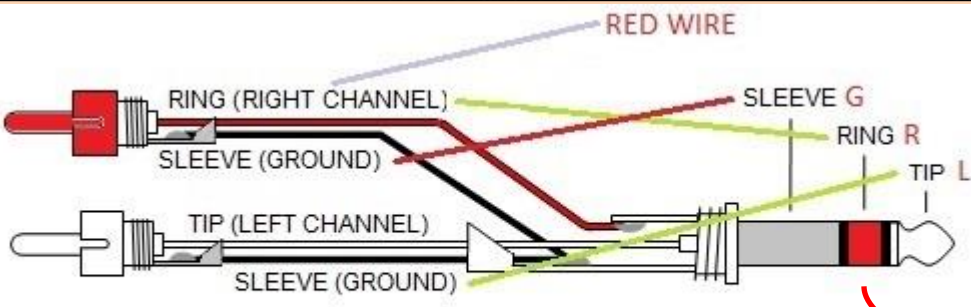

AUX / CD / MP3 input  
Mod AJ9500R  
cassette board pic

JOE BARRY

816 807 3946

shopcenturyautoair.comshopcenturyautoair.com

<b>Climate Control Systems</b>	
<b>Procedure via the Control Panel</b>	
	<b>Result</b>
and RECIRC – Switch	Display element check
	Any stored fault NUMERIC code no stored codes)
	Scroll through stored faults (max and HRV
	Clear stored fault codes (may ne fault)
skip actuator check)	Initiate actuator check (Actuator Exit error check mode
NOT equivalent to fault codes.	

shopcenturyautoair.com denso 10PA17C for Jaguar X300

**YOUTUBE Video ; Denso 10PA Series Compressor Reseal Part 1 and 2**

Denso 10PA Series Master Reseal Kit KT-10PA-SYS

SKU:



NOTE : NO  
PISTON SEALS  
NEEDED

\$28.00



DENXO 10PA17C Clutch Bearing NSK  
30BD5222DUM6 30mm ID x 52mm OD x 22mm Thick.jp



Int'l AC Parts



**INTLA/C PARTS**

INTL-CC019 clutch coil  
for 10PA15C  
for 10PA17C  
for 10PA20C  
24v

A=96.4mm  
B=61.6mm  
C=40mm  
D=27.6mm

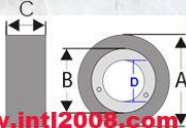

[www.intl2008.com](http://www.intl2008.com)

DENSO+10PA15C+10PA17C+10PA20C+AC+clutch+coil

[eurtonelectric.com](http://eurtonelectric.com)

Tel: (800) 423-4789

.15" x .15" x .35"

BRUSH 33A

Price: \$4.50 x 2 per motor

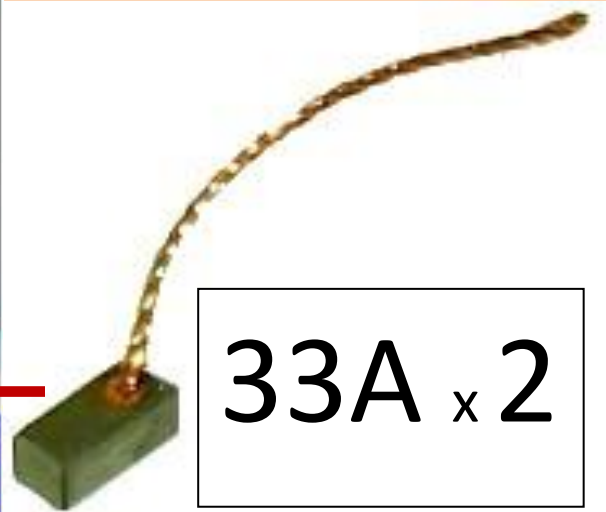

**33A x 2**

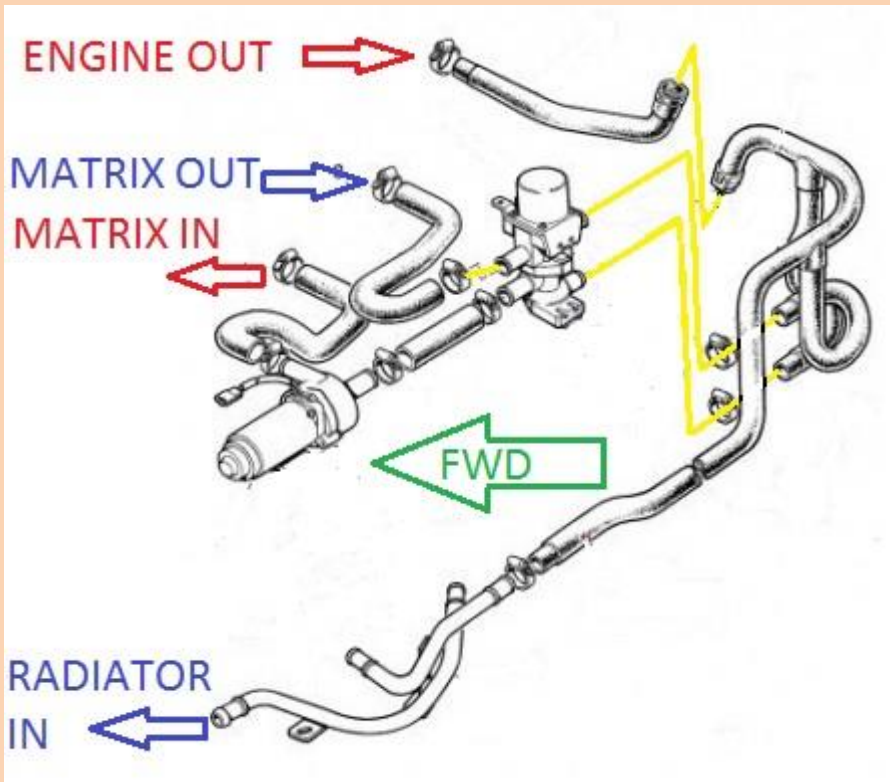

# Antifreeze Coolant Application Chart

For Passenger Vehicles and Light Duty Trucks



**Model Year**

1980 & Older   1985   1996   1997   1998   1999   2000   2001   2002   2003   2004   2005   2010 & Newer

American



European



Asian



**It's More Important Than You Think!**

- Automaker Approved Chemistry means the coolant chemistry:
- Is the same as specified by the automaker
  - Has been thoroughly tested to provide the same superior protection as the original fluid

To Place An Order  
Or For More Information  
Call 800-TEAM-VAL

\*Automaker approved for use in these applications

# Selecting The Right Chemistry



## Zerex Original Green

- Traditional green chemistry found in most early model year vehicles
- Low silicate formula is ideal for heavy duty applications
- Protects all cooling system metals while providing excellent high-temperature aluminum protection
- Meets and/or exceeds the following industry and engine specifications:  
GM1825M, GM 1899M, Ford ESE-M97B44-A, Chrysler MS 7170, ASTM D3306 & D4985, SAE J1034, J814C & J1941, TMC of ATA RP-302B, Federal Specifications A-A-870A, Detroit Diesel 7SE298, Cummins 90T8-4
- Product Color: Green

	<u>6/1 GALLON</u>	<u>55 GA DRUM</u>
Concentrate	ZX001	ZX002
Ready-To-Use	ZXR01	ZXR02



## Zerex G-05®

- 5 Year / 150,000 Mile Guarantee
- HOAT chemistry APPROVED for use in Mercedes Benz and newer Ford & Chrysler vehicles (see owner's manual for specific model years)
- Phosphate Free for use in European vehicles such as Volvo, BMW & MiniCooper
- Fully formulated to help prevent liner pitting in heavy duty diesel engines
- Meets and/or exceeds the following industry and engine specifications: Chrysler MS9769, Ford WSS-M97B51-A1, ASTM D3306, GM 1825M, GM 1899M, MTU MTL 5048, John Deere JDM H24, and MAN List 3.3.7
- Product Color: Yellow

	<u>6/1 GALLON</u>	<u>55 GA DRUM</u>
Concentrate	ZXG051	ZXG052
Ready-To-Use	ZXG05R01	ZXG05R02



## Zerex DEX-COOL®

- 5 Year / 150,000 Mile Guarantee
- OAT DEX-COOL APPROVED for use in GM vehicles produced since 1996 and SAAB vehicles since 2001
- Meets and/or exceeds the following industry and engine specifications:  
GM6277M, ASTM D3306, SAE J1034, J814 and J1941, TMC of ATA RP-302B, and Federal Specification A-A-870A
- Product Color: Orange

	<u>6/1 GALLON</u>	<u>55 GA DRUM</u>
Concentrate	ZXEL1	ZXEL2
Ready-To-Use	ZXELR01	ZXELR02



## Zerex Asian Vehicle

- 5 year /150,000 Mile Guarantee
- Silicate free, phosphated HOAT Chemistry specified by Asian vehicles
- Recommended for Toyota/Lexus, Honda/Acura, Nissan/Infiniti and other Asian vehicles
- Meets or exceeds the following industry and engine specifications:  
Hyundai/Kia MS 591-08, Mitsubishi ES-64217, JIS K 2234-1994, ASTM D3306, ASTM D4985, Ford WSS-M97B55-A.
- Product Color: Pink

	<u>6/1 GALLON</u>	<u>55 GA DRUM</u>
Ready-To-Use	675130	675129

TO PLACE AN ORDER OR FOR MORE INFORMATION CALL 800-TEAM-VAL

# Power Steering

Leak

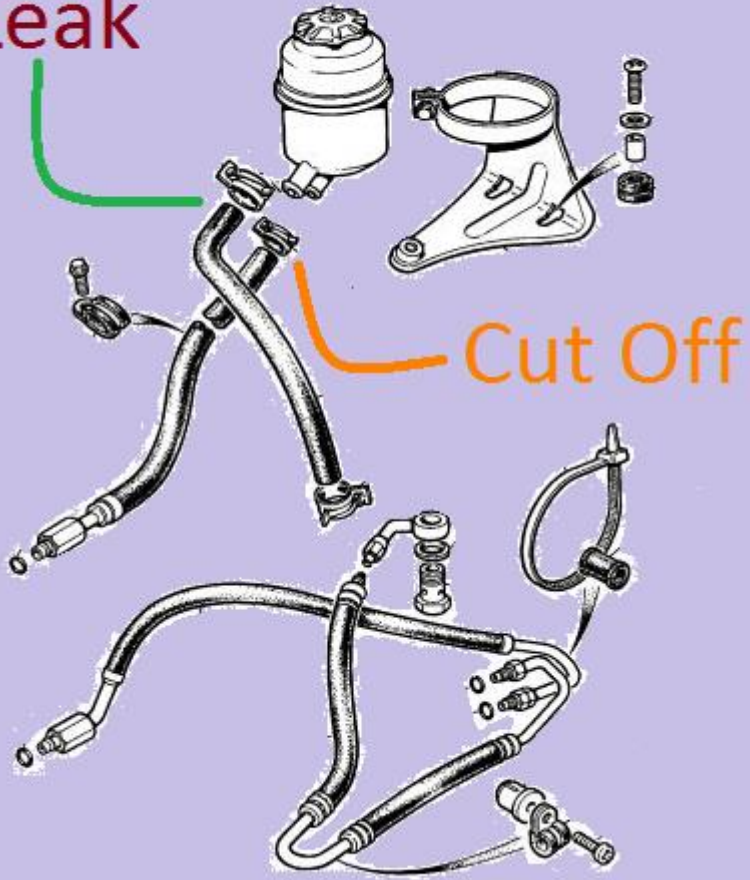





DIRTY

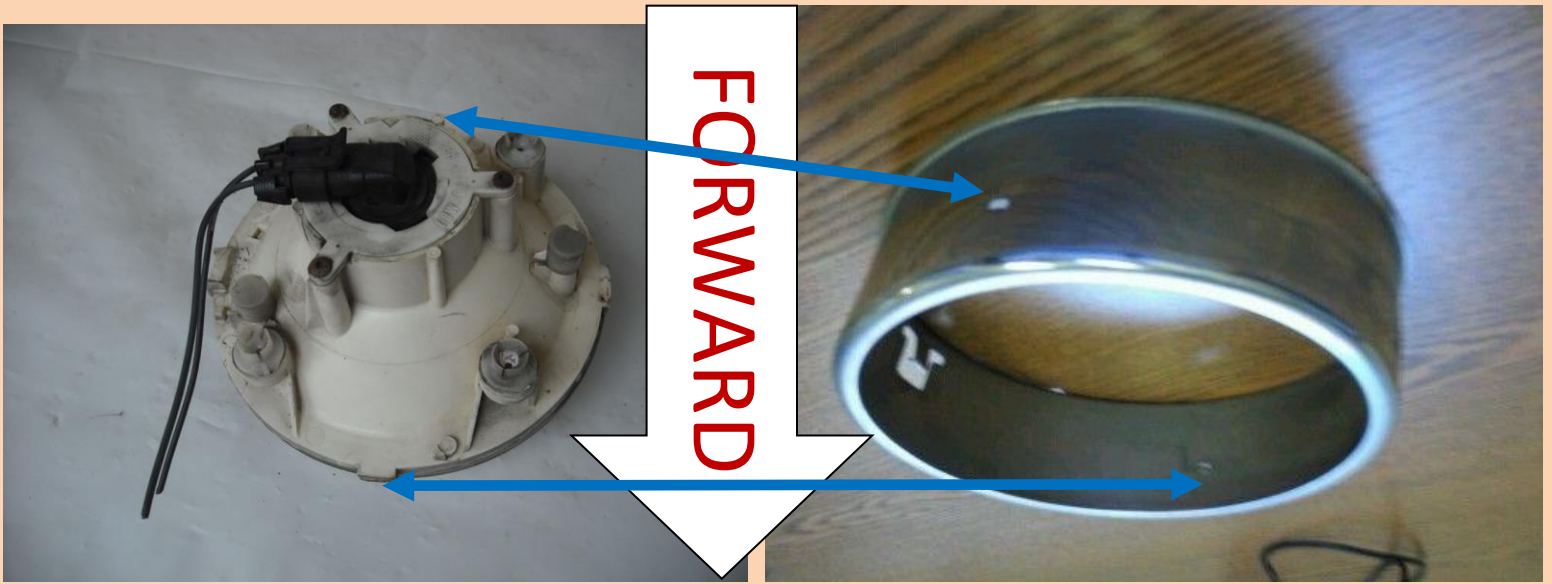
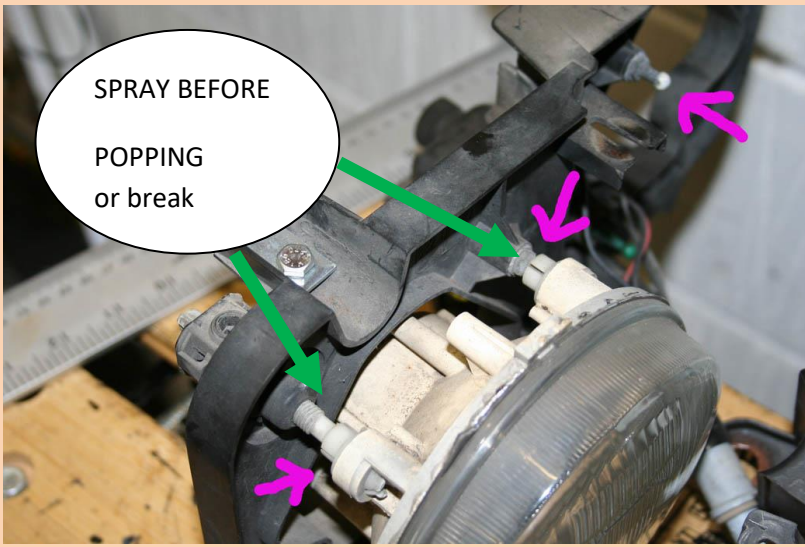

3 and 9 o'clock plastic tabs go aft or above chrome tabs

IDLER PULLY BEARING

GATES # 38006

3 inch

\$ 15 Autozone

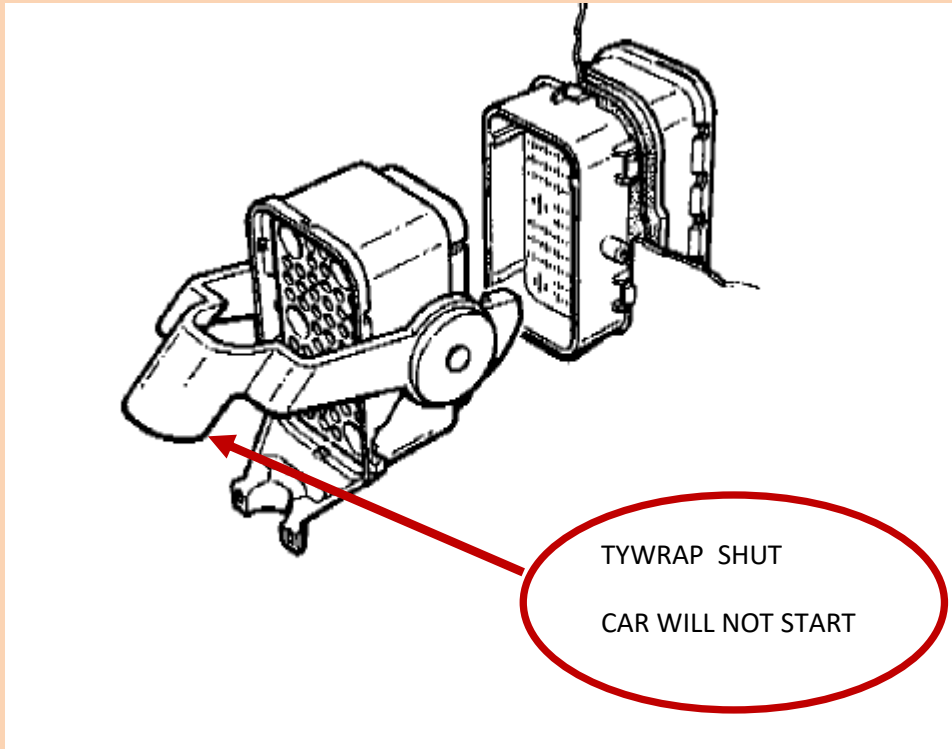
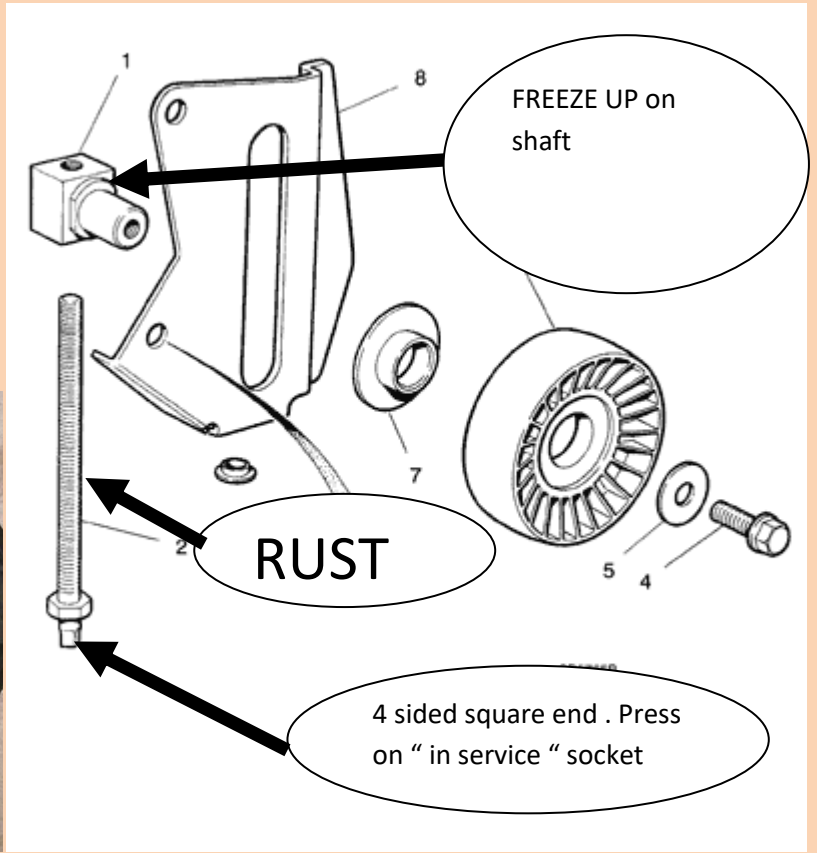

SECURITY MODULE CONNECTOR ( also LS3 - x ,RS3

- x , FC5 or 6 or 7 - x )



A/C EXPANSION VALVE INSIDE CABIN  
BURIED valve is forward of evaporator  
plate



Just cut plain mirror  
material . See You Tube  
video

ENGINE TROUBLE **PI ( Indy )1 - X**

13-way ECONOSEAL III

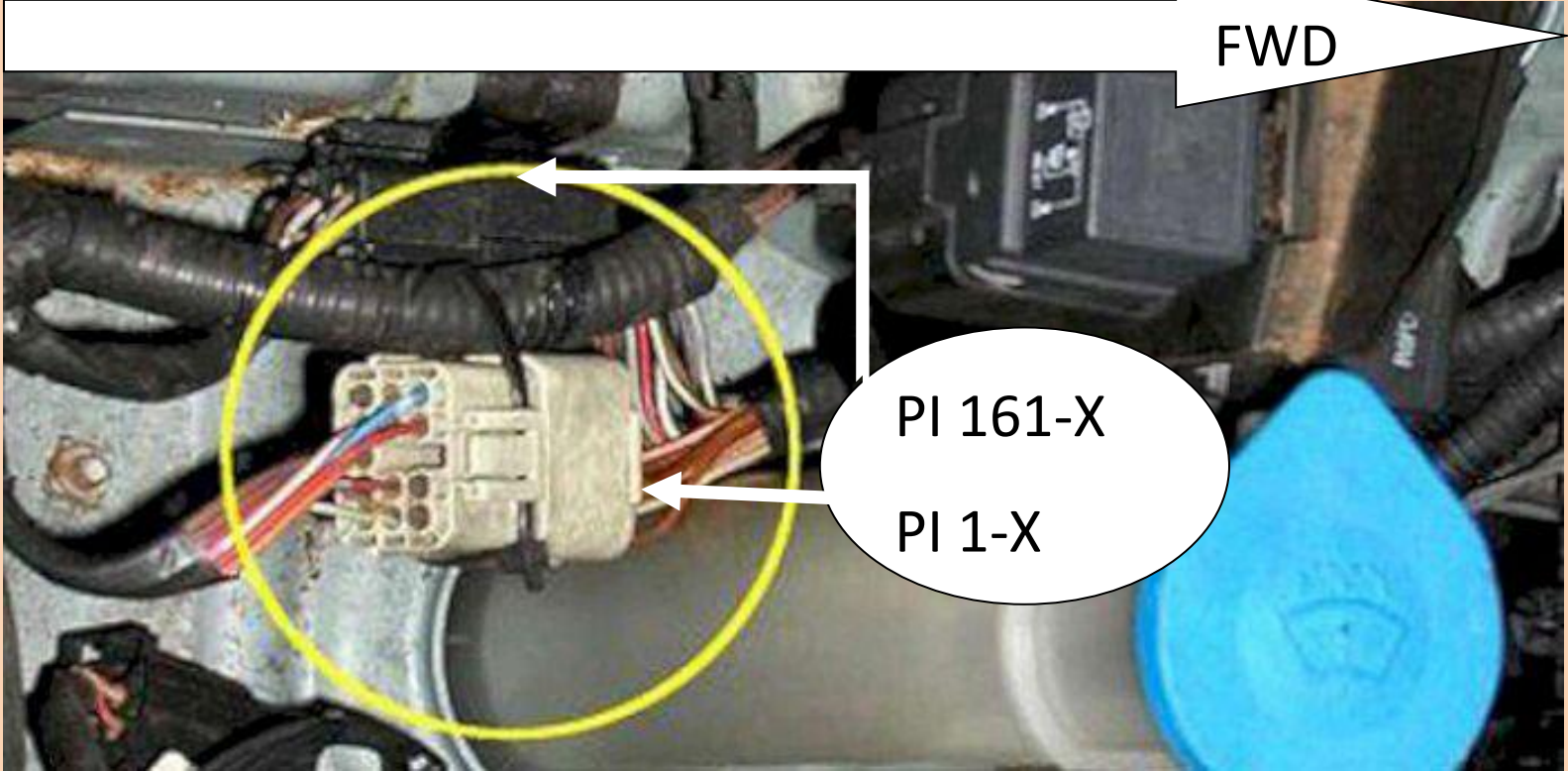

PI 161-X  
PI 1-X

# Rear of the RH headlamp

PI1 - 13-way ECONOSEAL III LC / WHITE and

PI61 - 13 way ECONOSEAL III LC / BLACK.

PI1-1 should be WY / WY

PI1-2 should be GB / GB

PI1-3 should be NY / NY

PI1-4 should be WK / WK

PI1-5 should be WO / WO

PI1-6 should be NO / NO

PI1-7 should be RS / RS

PI1-8 should be OS / OS

PI1-9

PI1-10

PI1-11 should be KB / KB

PI1-12 should be RO / RO

PI1-13 should be UW / UW

PI61-1

PI61-2 should be WU / WU

PI61-3 should be R / R

PI61-4 should be WU / WU

PI61-5

PI61-6 should be S / S

PI61-7 should be KN / KN

PI61-8 should be KR / KR

PI61-9 should be UR / UR

PI61-10 should be NLG / NLG

PI61-11 should be BW / BW

PI61-12 should be WG / WG

PI61-13 should be NO / NO

The colours are N = Brown, B = Black, W = White, K = Pink, G = Green, R = Red, Y = Yellow, O = Orange, S = Slate, L = Light, U = Blue, P = Purple.

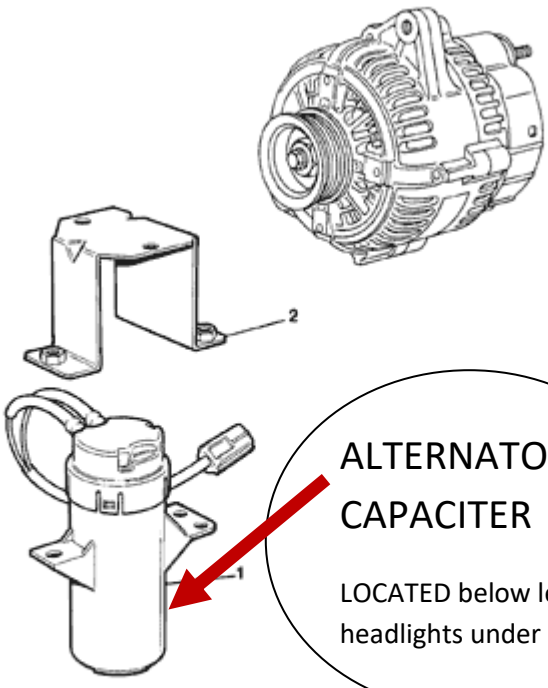

**ALTERNATOR  
CAPACITER**

LOCATED below left  
headlights under car

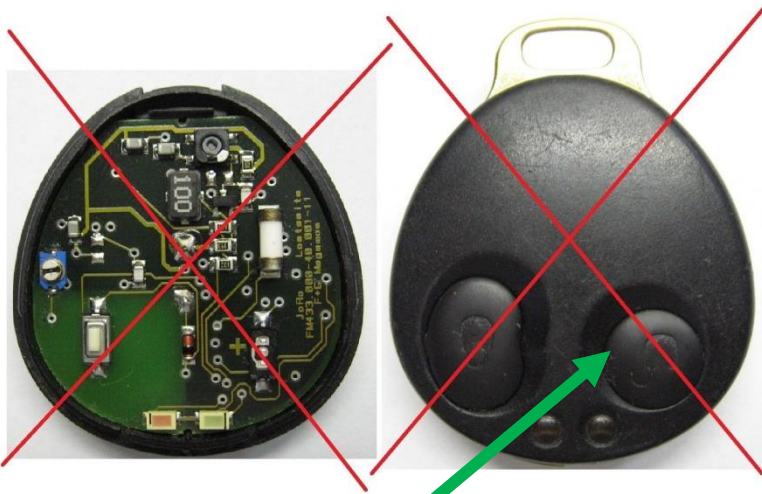

**2X SWITCH FOR REPAIR**

EBAY

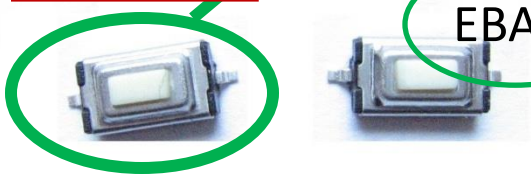

**fits Jaguar  
X300 XJ6 XJ12**

*polmex\_buttons*

Made In Australia

EBAY

You are buying Key Buttons Only ! Shells and all components shown in the attached images, are for Reference Only & are NOT INCLUDED with this listing

**2 Silicone Buttons**

CHEEP  
LEATHER  
RESORE  
ONLY  
FOUND AT  
SALLY  
BEAUTY  
SUPPLY  
BARRY AND NORTH  
OAK  
use medium  
toothbrush / let set



# CRACK

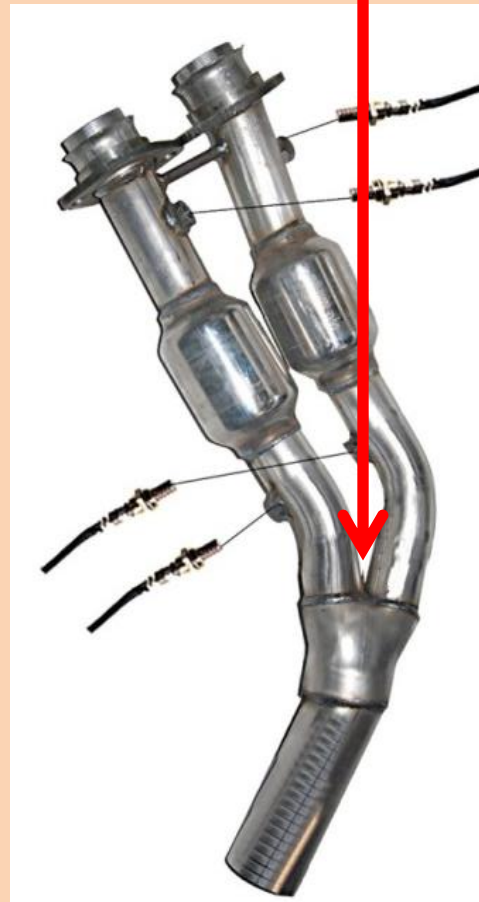
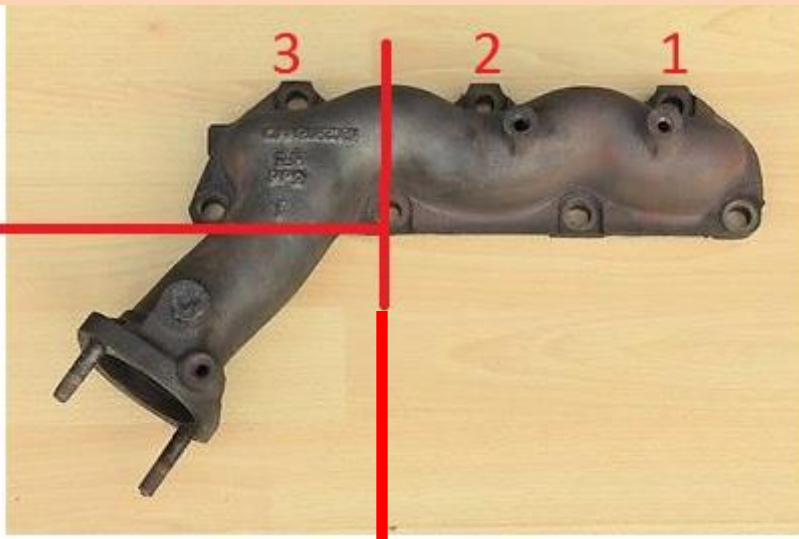



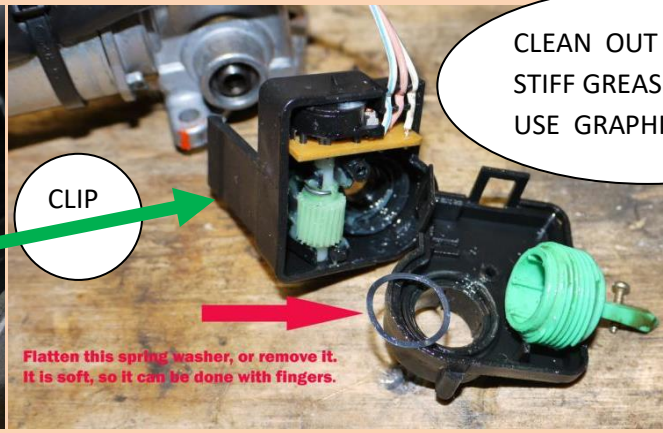
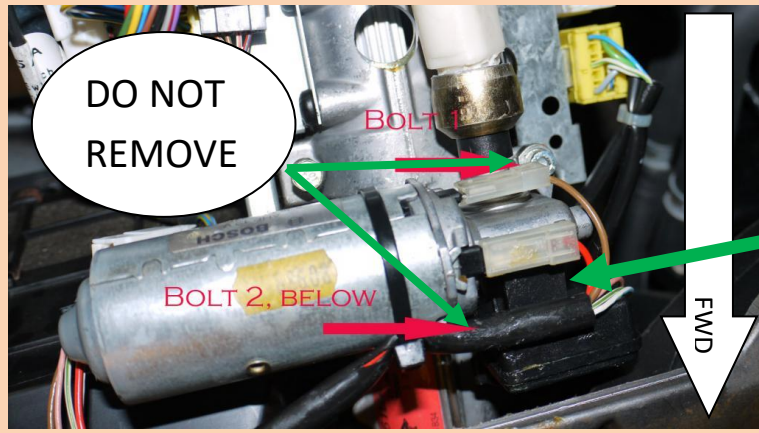

# 1 FUSE  
+ BATTERY  
# 10 FUSE  
KING RELAY



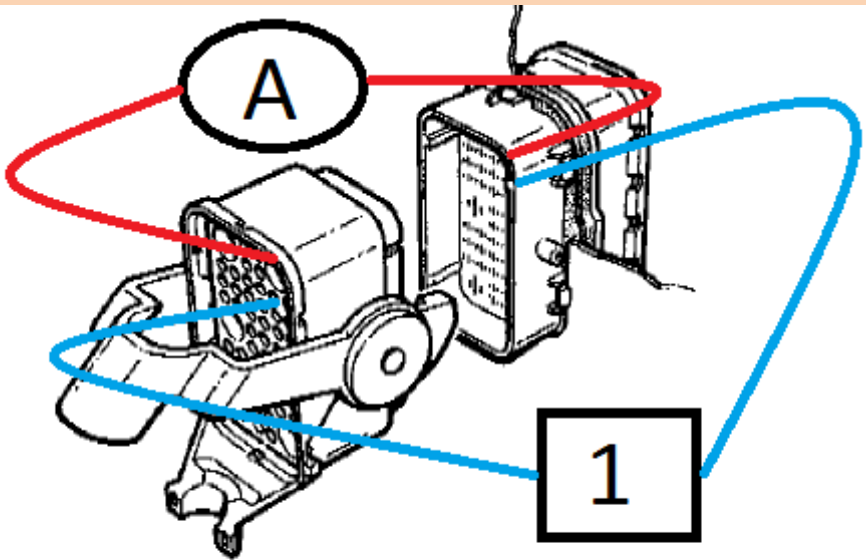

D						A	
						7	1
						8	2
							3
E						B	
							4
							5
							6
F						C	



LNA6706AA

CIGAR LIGHTER

**Positive terminal appears to be too short to make contact to 12V accessories.**

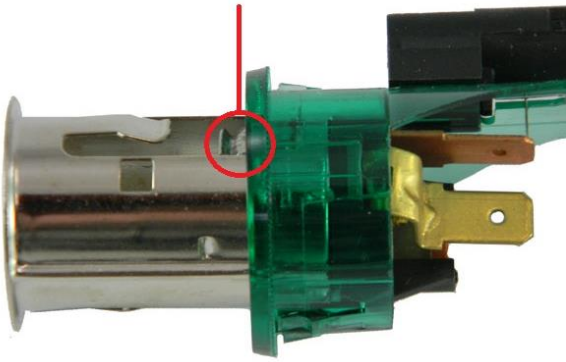

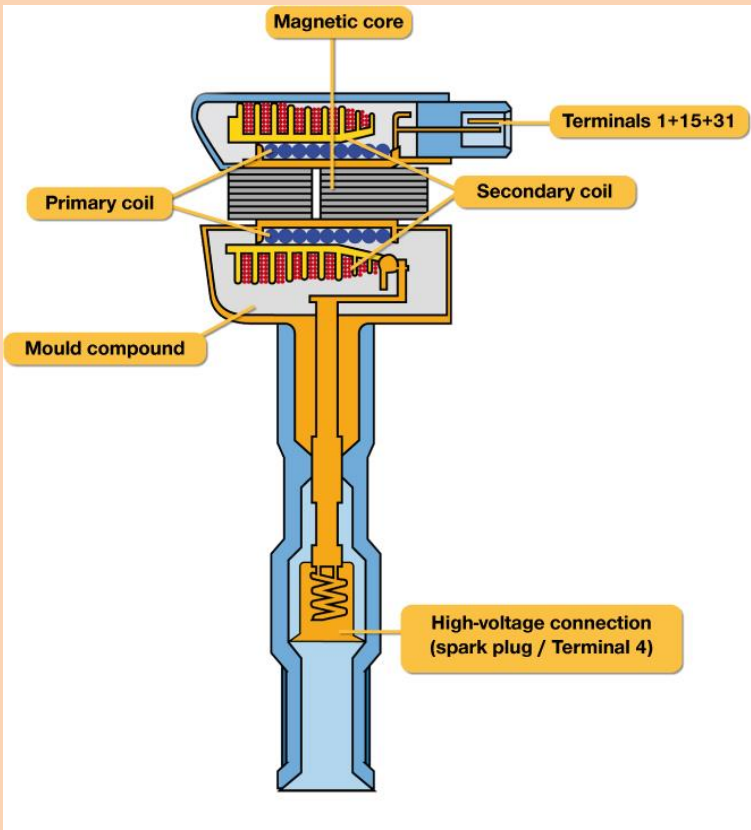

KAPTON TAPE

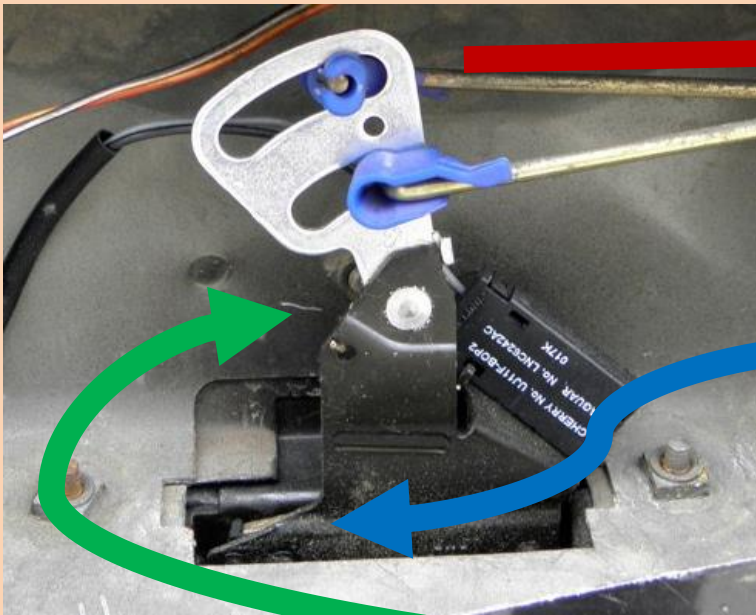

Normal Operation  
rotate to passenger  
side

Middle bar slides to  
driver side

Hidden bar rotates to  
driver side to open





BATTERY TRAY and Springs





C

A/C Temp Sensor

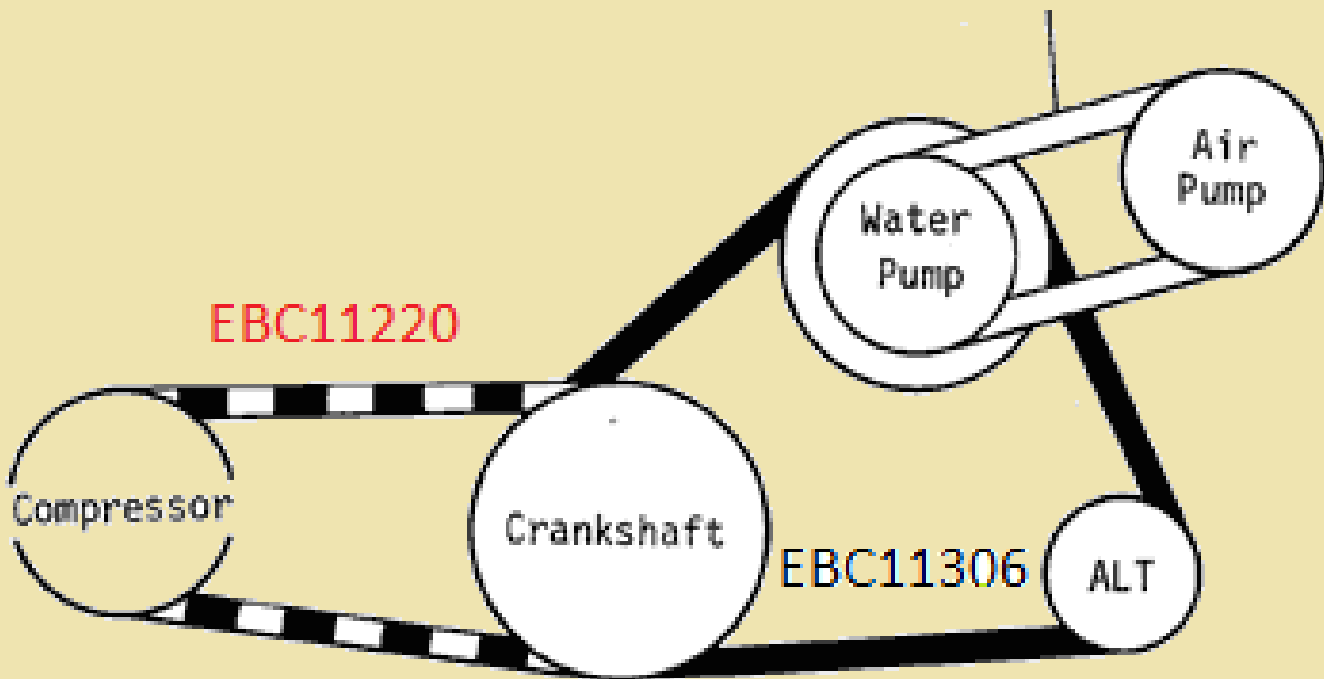

VS4721



**BILSTEIN**<sup>®</sup>



**BILSTEIN**<sup>®</sup>



# FRONT END KNOCK

GAP

BAD

U  
N  
L  
O  
A  
D  
E

