

**New Special Tool 18G 1433/A –  
Camshaft Timing**

**MODEL** 1995 MY  
Sedan (4.0L) Range  
**VIN**  
720001-ON

**ISSUE:**

A new camshaft timing tool has been introduced for the AJ16 engine as part of the 1995/1996 model year tool package. The tool details are as follows:

TOOL NUMBER	DESCRIPTION	PRICE
18G 1433/A	AJ16 Camshaft Timing Tool	\$103.25

**ACTION:**

18G 1433/A is a redesigned camshaft timing tool used when setting camshaft timing. It is 3 mm thinner to accommodate the dimensions of the AJ16 cylinder head. It can also be used on AJ6 engines.

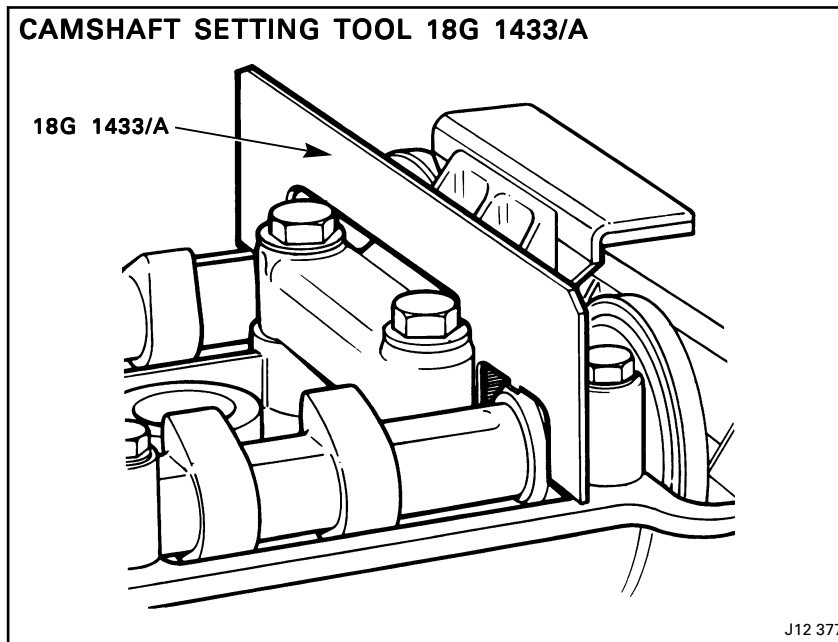

ILLUSTRATION 1