



1996 / 1997 MY Technical Guide

Technical Guide

1996 MODEL YEAR

XJ6 & XJ12 RANGE

1996 MODEL YEAR

XJ6 & XJ12 RANGE

1996 MODEL YEAR

XJ6 & XJ12 RANGE

1996 MODEL YEAR

XJ6 & XJ12 RANGE

1996 MODEL YEAR

XJ6 & XJ12 RANGE

1996 MODEL YEAR

XJ6 & XJ12 RANGE

1996 MODEL YEAR

XJ6 & XJ12 RANGE

1996 MODEL YEAR

XJ6 & XJ12 RANGE

1996 MODEL YEAR

XJ6 & XJ12 RANGE

1996 MODEL YEAR





BY APPOINTMENT TO
HER MAJESTY QUEEN ELIZABETH II
MANUFACTURERS OF DAIMLER AND JAGUAR CARS
JAGUAR CARS LIMITED COVENTRY



BY APPOINTMENT TO
HER MAJESTY QUEEN ELIZABETH
THE QUEEN MOTHER
MANUFACTURERS OF DAIMLER AND JAGUAR CARS
JAGUAR CARS LIMITED COVENTRY



BY APPOINTMENT TO
HIS ROYAL HIGHNESS THE PRINCE OF WALES
MANUFACTURERS OF DAIMLER AND JAGUAR CARS
JAGUAR CARS LIMITED COVENTRY

Technical Guide

XJ6 & XJ12 RANGE 1996 MODEL YEAR

This Technical Guide is produced as an outline description of the model year program changes to the XJ Series Sedan range, for Dealer workshop personnel. As a cohesive package, it complements updates to the Service Manual. However, in order to keep the contents concise, no attempt is made to cover technical details to the depth of the Service Manual.

Most of the changes are programmed for introduction in early May 1995. Some are running changes to be included as close as possible to this date.

The information contained in this publication should be considered as preliminary information. While every effort is made to ensure accuracy, changes may occur between going to press and vehicle launch. Since the Technical Guide contents will not be updated, the reader is encouraged to study subsequent information sources, such as Service Bulletins and Service Manual Supplements.

Subject	Page
Introduction	2 - 6
Vehicle Technical Features	3
Vehicle Identification Number (VIN)	5
Dimensions	6
Body	7 - 7
Exterior Trim	7
Interior Trim	7
Trunk	7
Chassis	8 - 8
Brakes	8
Electrical/Electronic	9 - 21
Power Distribution	9
Switchgear	10
Instruments	10
Seat Heater System	11
Relays, Fuses and Control Modules	13
Diagnostics	22 - 22
Engine Control Module	22

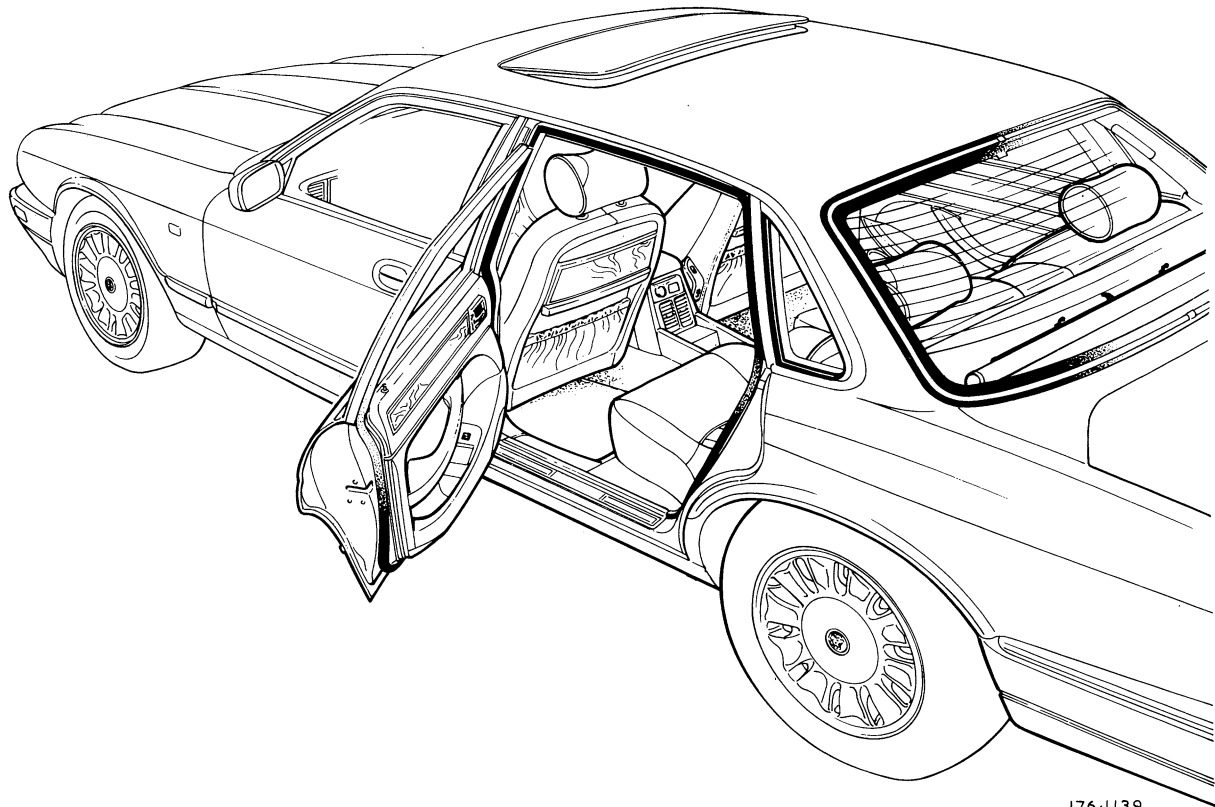

J76-1139

The Jaguar XJ Sedan range, first introduced at 1995 model year, is broadened to include an extended wheelbase model. The wheelbase is 125 mm longer than the standard wheelbase, with the extra length being introduced behind the B/C post. The result is increased rear door length and rear passenger leg room.

Seat heaters are introduced to the rear seats. The switches for the heaters are on a rear extension to the front center console.

To enable the front passenger seat to be adjusted by a person in the rear seat (or by the driver), a switch housing is introduced on the front passenger seat squab. Two switches enable fore/aft and recline adjustments.

Minor modifications include a revised spare wheel mounting arrangement in the trunk, and a door glass thickness increase to 5 mm.

Revisions are made to the engine control module software on both six and twelve cylinder vehicles.

Vehicle Technical Features

The features of the extended wheelbase vehicles, that distinguish them from the standard wheelbase vehicles, are detailed below.

All VDP and XJ12 models have the extended wheelbase. XJ6 and XJR models are only available in standard wheelbase specification.

X = Standard equipment

O = Optional equipment

Feature	VDP	XJ12
Body: complete assembly	X	X
Body in white extended 125 mm behind B/C post		
Rear doors extended by 125 mm		
Inner sill panel extended 125 mm	X	X
Trunk floor		
New bracket mounting for spare wheel	X	X
Roof panel - extended 125 mm		
Increased rear curvature in plan view to provide additional rear headroom	X	X
Main floor rear tunnel reinforcement	X	X
New console extension brackets		
Drip moulding	X	X
New panel of increased length and revised profile		
Rear door assembly	X	X
Inner and outer waist reinforcements extended 125 mm		
New bracket for rear side intrusion rail		
Rear door inner to incorporate larger speaker aperture to improve ICE performance		
Frame assembly 125 mm extended top section		
Door glass and carrier		
New rear door glass - 5 mm to suit extended door and frame	X	X
New front door glass - 5 mm		
New rear door glass run channel to suit extended length and 5 mm glass		
Finisher frame rear door top: 125 mm extended - bright	X	X
New assembly waist seal outer	X	X
Handles and latches rear door	X	X
New assembly handle remote control - extended cable		
Water deflector - rear door	X	X
New moulding extended 125 mm and incorporating a separate bonded-in cup to provide deeper recess behind speaker to improve ICE performance		
Assembly rear door casing complete	X	X
New door casing and pocket, extended 125 mm		
New front mounting bracket for armrest	X	X
Rear door top roll and veneer extended 125 mm	X	X
Front seats - switches in veneered finisher fitted to squab inboard side of passenger seat for operation of passenger seat from rear and from driver	X	X
Center console extension with two rear seat heater switches	O	O

Feature	VDP	XJ12
Rear seats - bench type or 2 seat type with or without cushion heaters	X	X
Drive shaft - extended barrel with carry over pre-1995 MY extended wheelbase center bearing mounting bracket		
4.0 L Auto	X	
6.0 L Auto		X
Underfloor pipe cluster - extended 125 mm in rear floor section		
Assembly - non-traction control	X	
Assembly - traction control		X
Exhaust system		
New assembly exhaust intermediate mufflers with front pipe extended 125 mm	X	X
Electrical harnesses - the following harnesses are new to accommodate additional 125 mm:		
Cabin harness	X	X
ICE harness - standard ICE	X	
- premium ICE	O	X
Rear door harnesses	X	X
Radio telephone harness	X	X
Battery positive cable	X	X
Heelboard fuse box cable	X	X
Seat harnesses		
Power front seat harness (part of seat assembly) for front passenger seat adjustment from the rear	X	X
Heated rear seat link lead	O	O
Spare wheel fixings/Jack and wheel brace stowage		
Modified fixings and jack stowage to suit new spare wheel mounting bracket	X	X
Parking brake, carryover pre-1995 MY extended wheelbase cable	X	X
Windshield - revised mirror mounting button	X	X
Backlight and finisher		
New backlight glass with increased curvature of roof/rear header	X	X
Glazing rubber extrusion to different length		
Four piece bright finisher with extra joint/clip on vertical sections		
Body deadening		
Underfloor acoustic liner - extended 2 piece with joint in rear tunnel area	X	X
Carpets		
Assembly moulded carpet and insulation main floor extended 125 mm in rear footwell area	X	X
Rear seat heater control modules mounted on existing spare relay tags on rear heelboards	O	O
Roof liner extended 125 mm to suit revised roof panel profile	X	X
Finishers - A, B/C and D/E post and door apertures - flange finishers extended to suit new rear door aperture, A post/cantrail finisher extended at rear	X	X

Feature	VDP	XJ12
New rear door seals, and secondary seals modified to suit increased rear door size	X	X
Rear door body side mouldings extended by 125 mm	X	X
Rear treadplates extended 125 mm, added fixing hole, 'Jaguar' script	X	X
Drip moulding finisher extended 125 mm	X	X
Door cappings extended 125 mm	X	X

Vehicle Identification Number (VIN)

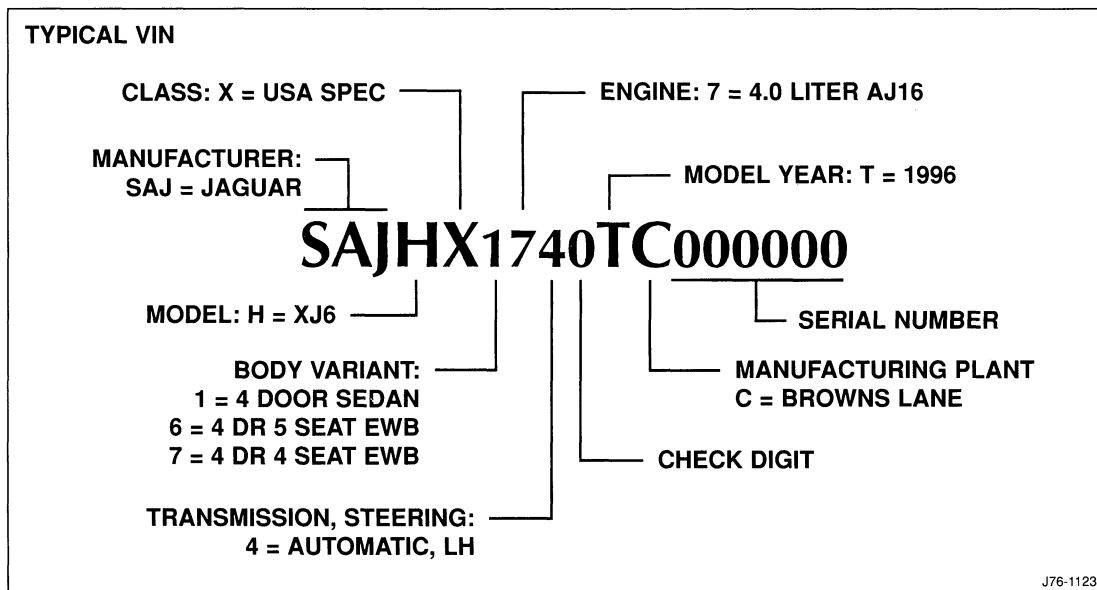

Dimensions

EXTERNAL DIMENSIONS

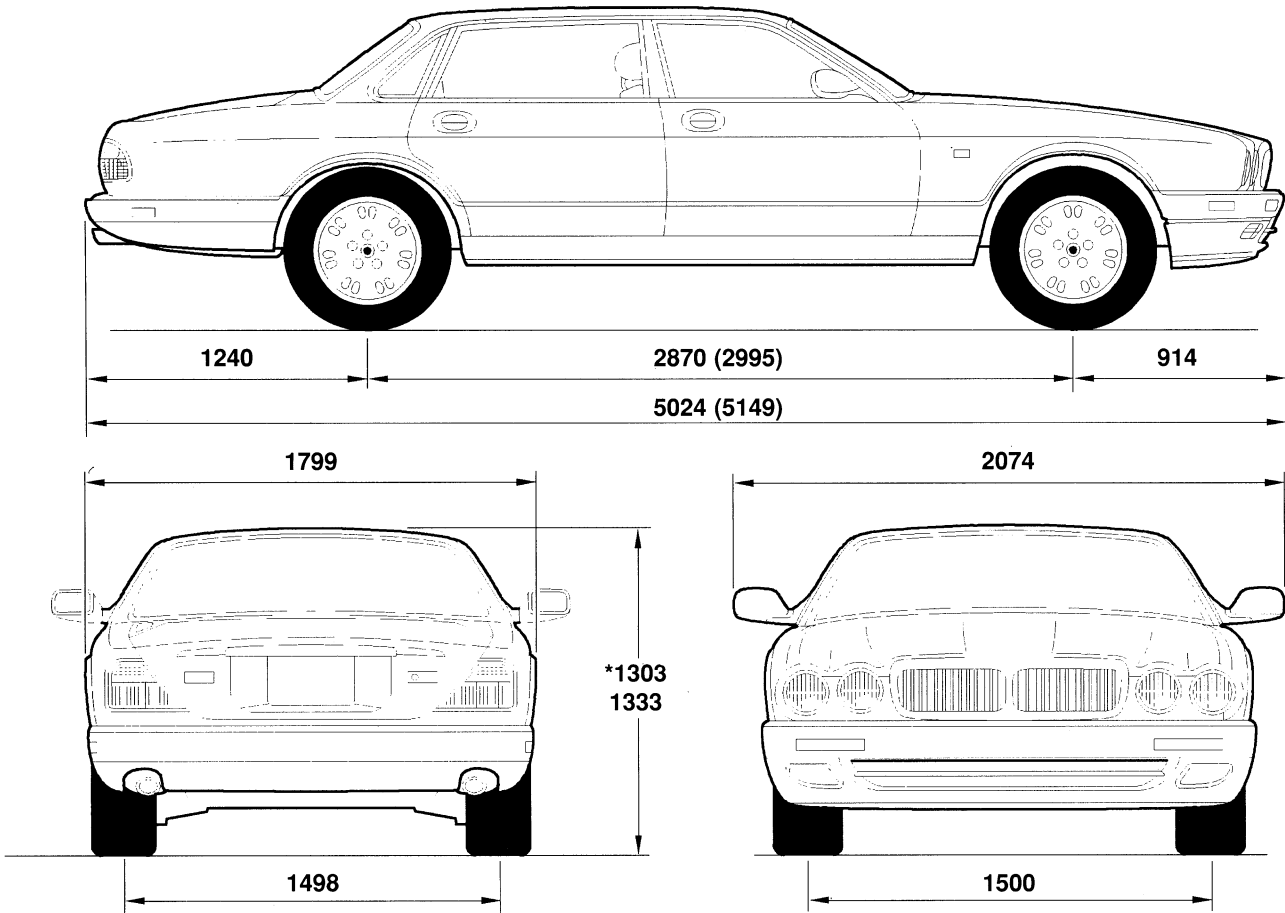

* Height range is for full model range, no option to full option at gross vehicle weight.

All dimensions are in mm and, except for wheelbase and overall length, applicable to all models. Wheelbase and overall length are for standard wheelbase (extended wheelbase).

J76-1125

Exterior Trim

Door Windows

To reduce wind and road noise, the thickness of the window glass in the doors is increased from 4 mm (0.16 in) to 5 mm (0.20 in). New glass run channels accommodate the thicker glass.

Interior Trim

Rear View Mirror

The interior rear view mirror has a revised stem and windshield mounting button. The stem locates on grooves in the mounting button. Spring clips in the stem lock the two together.

A plastic cover clips onto the stem to conceal the mounting. With the cover removed, the stem can be unlocked from the mounting button by a sharp downward blow to a suitable protective block positioned on the rear top edge of the stem.

REAR VIEW MIRROR AND MOUNTING BUTTON

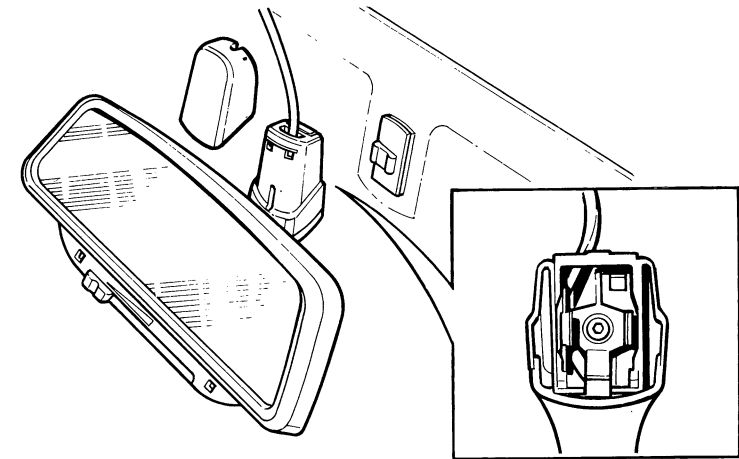

J76-2073

Trunk

Spare Wheel Installation

A new stowage tray and spare wheel mounting is introduced. On vehicles with a temporary-use spare wheel, this enables the three rubber spacer blocks to be deleted.

A yellow plastic clamping bolt secures the stowage tray to the mounting. An L-shaped bolt, installed through one of the spare wheel stud holes and the clamping bolt, secures the spare wheel.

The L-shaped bolt comes in one of two lengths, to fit either the temporary-use or full size spare wheels. The blade ended handle of the bolt is for removing wheel trims, replacing the dedicated trim tool previously installed in the stowage tray. The stowage tray in vehicles with a temporary-use spare wheel no longer contains a securing bolt for a full size wheel, because a full size wheel will only be carried in the trunk on a temporary basis.

A new lugnut wrench, with a telescopic handle, is installed in the stowage tray.

Caution:

The handle should only be extended for loosening lugnuts, not tightening them. Using the wrench with the handle extended to tighten lugnuts could damage the stud/lugnut threads.

SPARE WHEEL MOUNTING

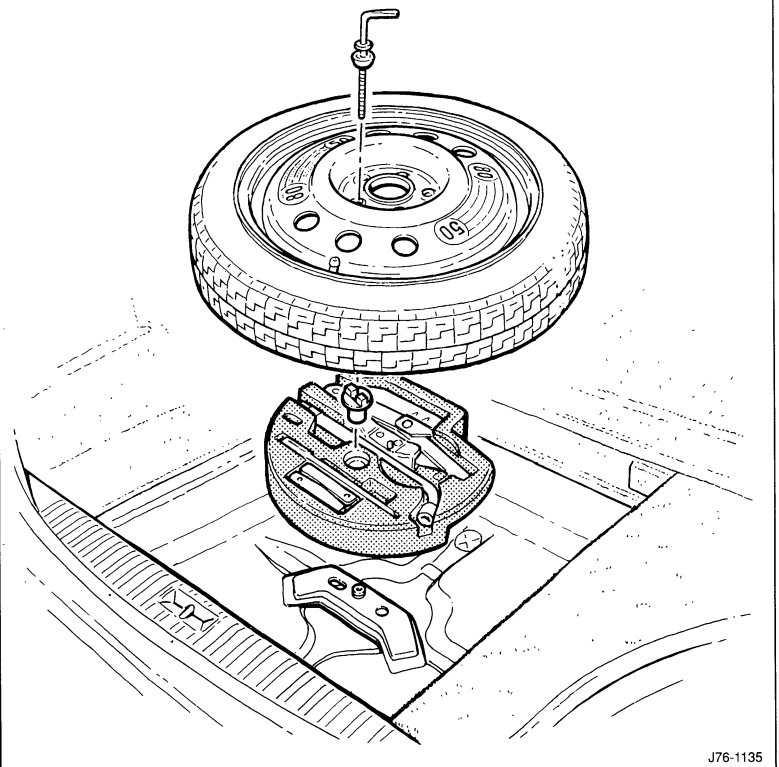

J76-1135

Brakes

Rear Brake Pipe and Hose

A horseshoe shaped snap-on clip is now fitted to the body longitudinal bracket. The shape of the bracket is bent inboard. The flexible hose has a female end fitting which is 'D' shaped to locate in the longitudinal bracket. Consequently, the mating underfloor pipe is changed to a male end fitting. The pipe has an altered bend to route it to the new mating position. This provides a simplified remove/refit procedure and improves access.

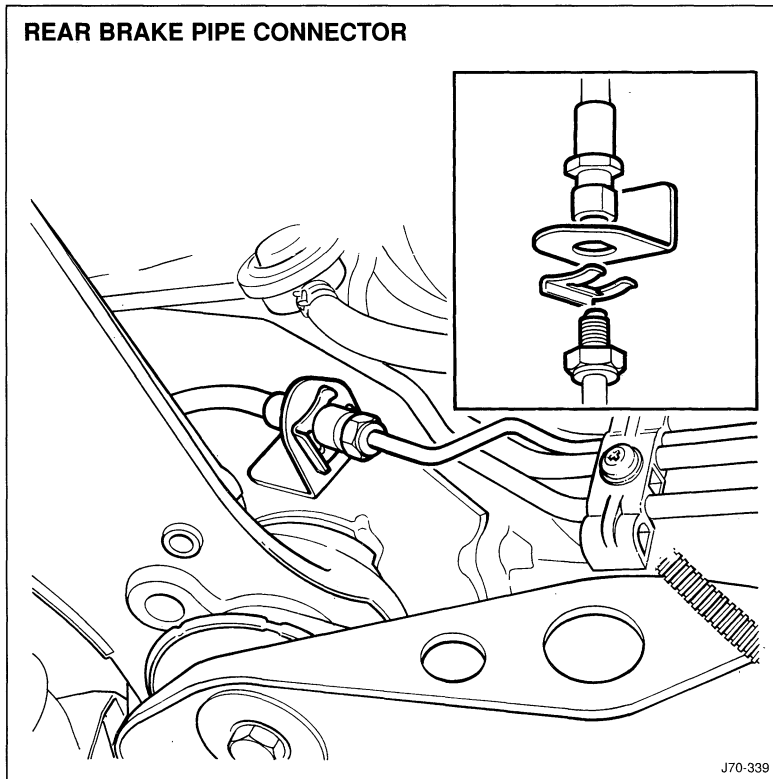

Power Distribution

Wiring Harnesses

On vehicles with heated rear seats, a rear seat link harness provides the interface with the cabin harness. The connector between the link harness and the cabin harness is located on the right rear seat pan, below the insulation layer.

REAR SEAT LINK HARNESS

Connectors - Link Harness to:

1. Cabin Harness, CA109
2. RH Seat Heater, BS005
3. LH Seat Heater, BS003
4. LH Heater Switch, BC001
5. RH Heater Switch, BC002

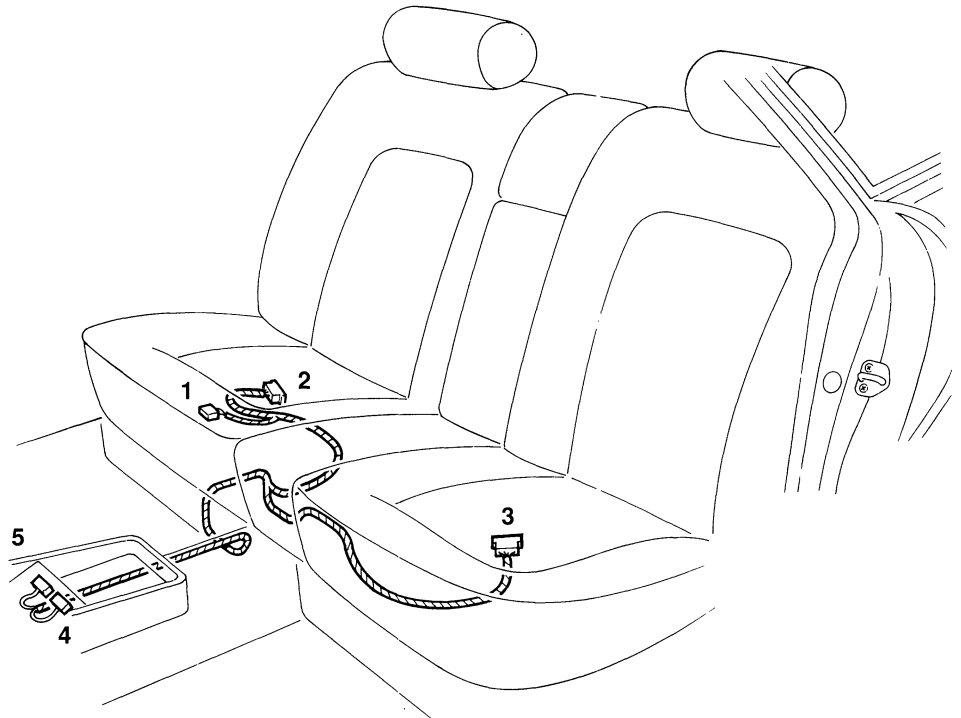

J86-2089

Cabin Accessory Connector

On VDP and XJ12 models, the accessory connector in the passenger compartment is located on the RH heelboard instead of the LH A-post.

CABIN ACCESSORY CONNECTOR - VDP AND XJ12

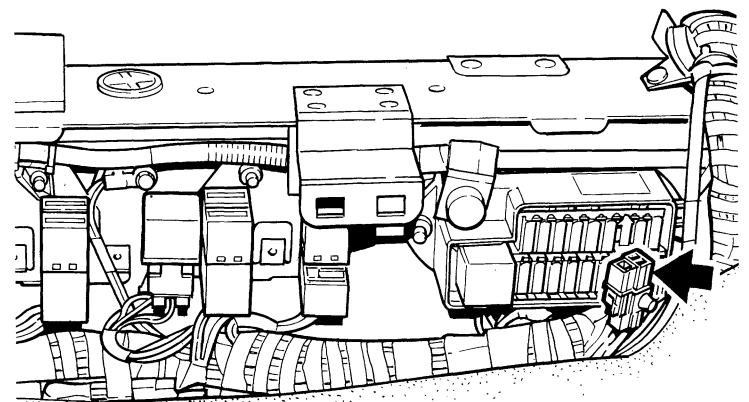

J86-2116

FRONT PASSENGER SEAT SWITCHES

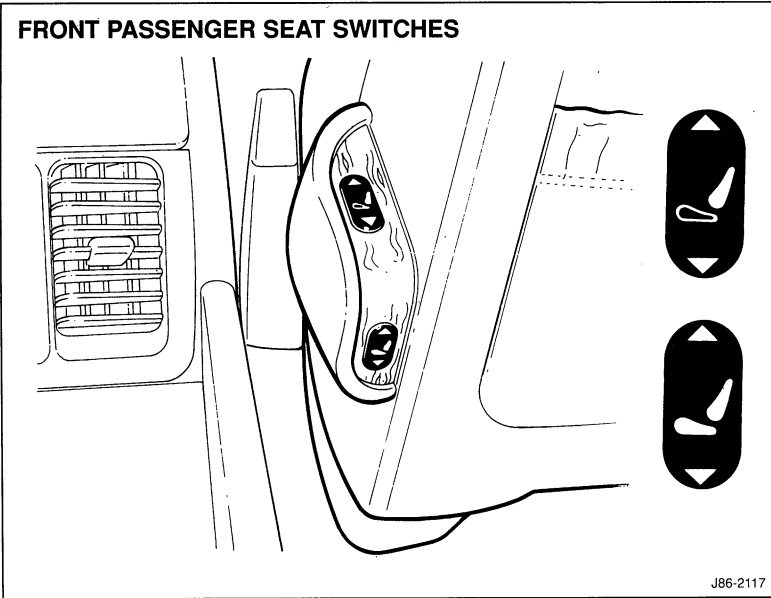

J86-2117

Switchgear

Front Passenger Seat Switches

On VDP and XJ12 models, two additional switches are introduced to enable operation of the front passenger seat fore/aft and recline adjustments by a rear passenger or the driver. The switches are installed on a finisher, in a housing attached to the inboard side of the passenger seat squab. The housing is trimmed to match the seat trim. The switches are illuminated, three position rocker switches, spring-loaded to the center (off) position.

A revised seat harness connects the new switches in parallel with the related adjustment switches on the seat cushion.

Instruments

Oil Pressure Indication

To avoid nuisance low oil pressure warnings at engine idle rpm, the engine oil pressure transducer is replaced by an oil pressure switch. This changes the operation of the oil pressure gauge on the instrument panel. New graphics on the oil pressure gauge complement the revised operation.

The gauge now reads mid-scale (N) at all normal driving conditions, and only deflects from mid-scale (full left, into or below the red sector) if a genuine low oil pressure condition occurs.

The switch operates at 0.14 to 0.41 bar (2 to 6 lbf/in²), and is torque tightened to between 11 and 13.5 N.m (98 and 119 lbf.in), on both AJ16 and V12 engines.

OIL PRESSURE SWITCH

AJ16 Engine

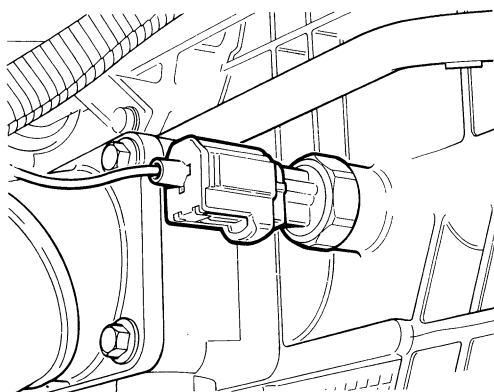

V12 Engine

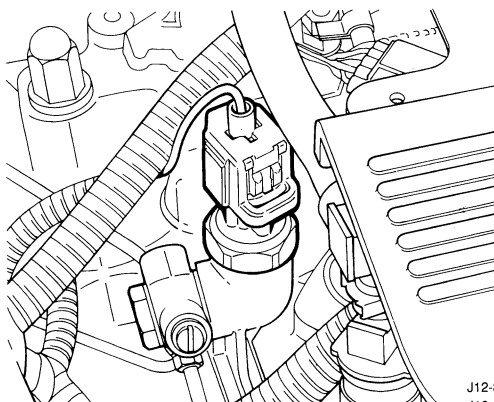

J12-863
J12-864

OIL PRESSURE GAUGE

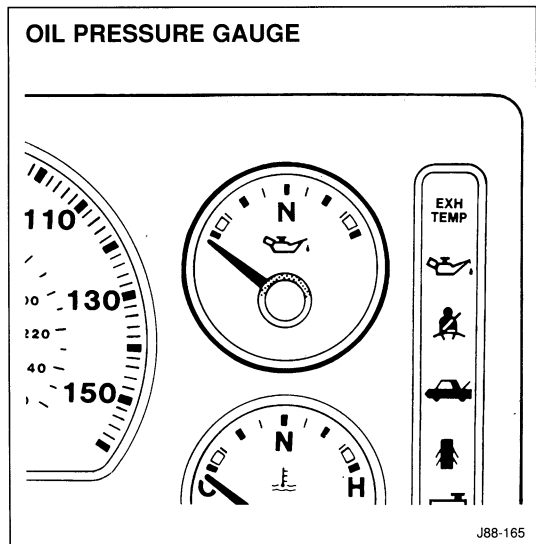

J88-165

Seat Heater System

Rear Seat Heaters

Rear seat heaters are introduced as an option for VDP and XJ12 models. The heater system for each seat position consists of two heater elements, a control module and a control switch.

Heater Elements

Separate heater elements are installed in the cushion and the squab of each seat. The temperature of the two elements at each seat position is controlled by a thermostat in the respective cushion heater element.

Control Modules

The control modules are 10 to 12 minute timer relays. The control module for each seat is installed on the related heelboard.

Control Switches

The control switches are installed on the rear extension of the front console. They are push on/push off type switches with a status indicator.

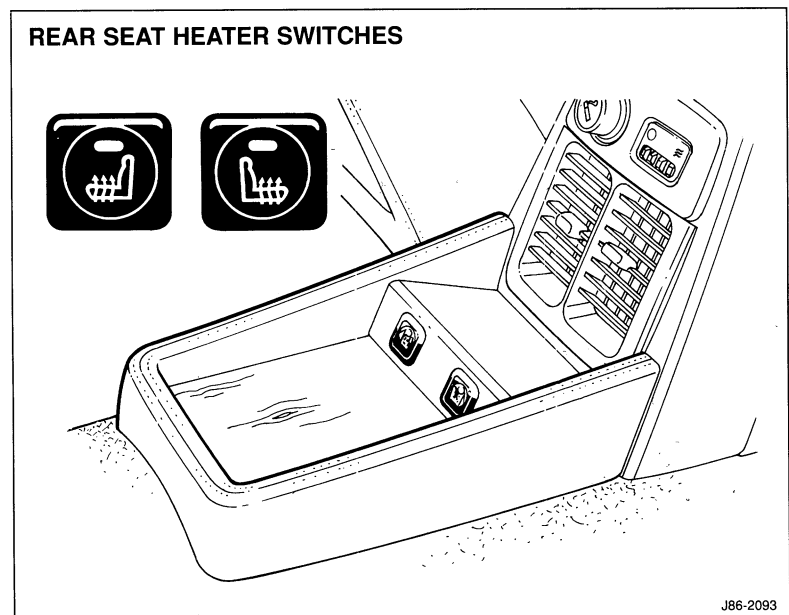
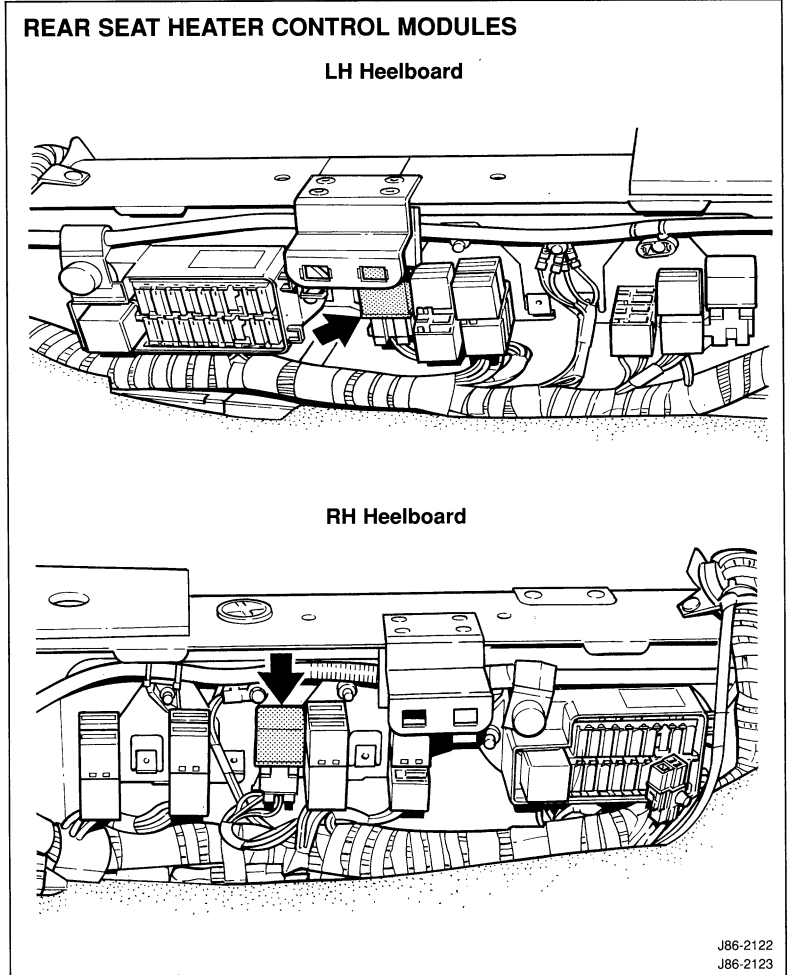

Operation

With the ignition on, when a control switch is pressed the related control module connects a supply to the heater elements. The thermostat then regulates the supply to maintain the cushion and squab heater elements at a temperature of 30 to 45 °C (86 to 113 °F).

After 10 to 12 minutes the control module automatically de-energizes and disconnects the supply to the heater elements. The system then remains off until the control switch is pressed again. The control module also de-energizes if the control switch is pressed again before the 10 to 12 minutes time delay has elapsed.

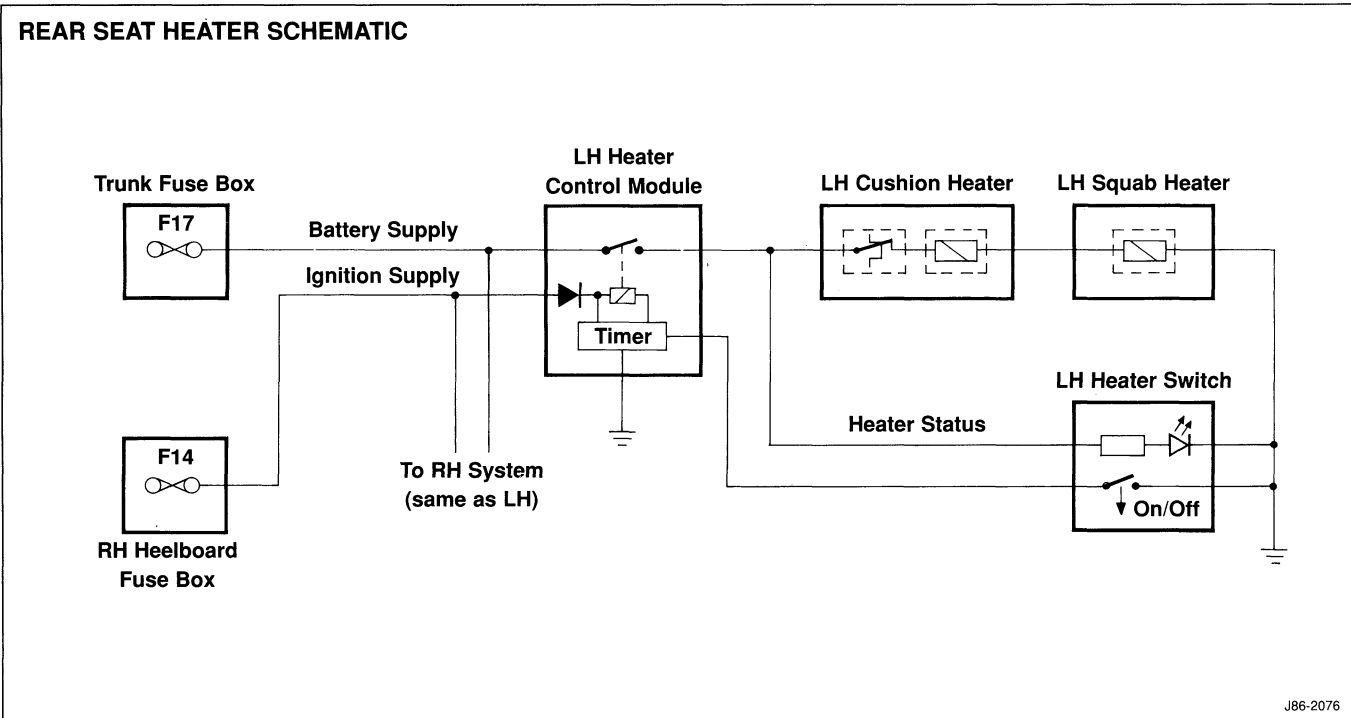

Relays, Fuses and Control Modules

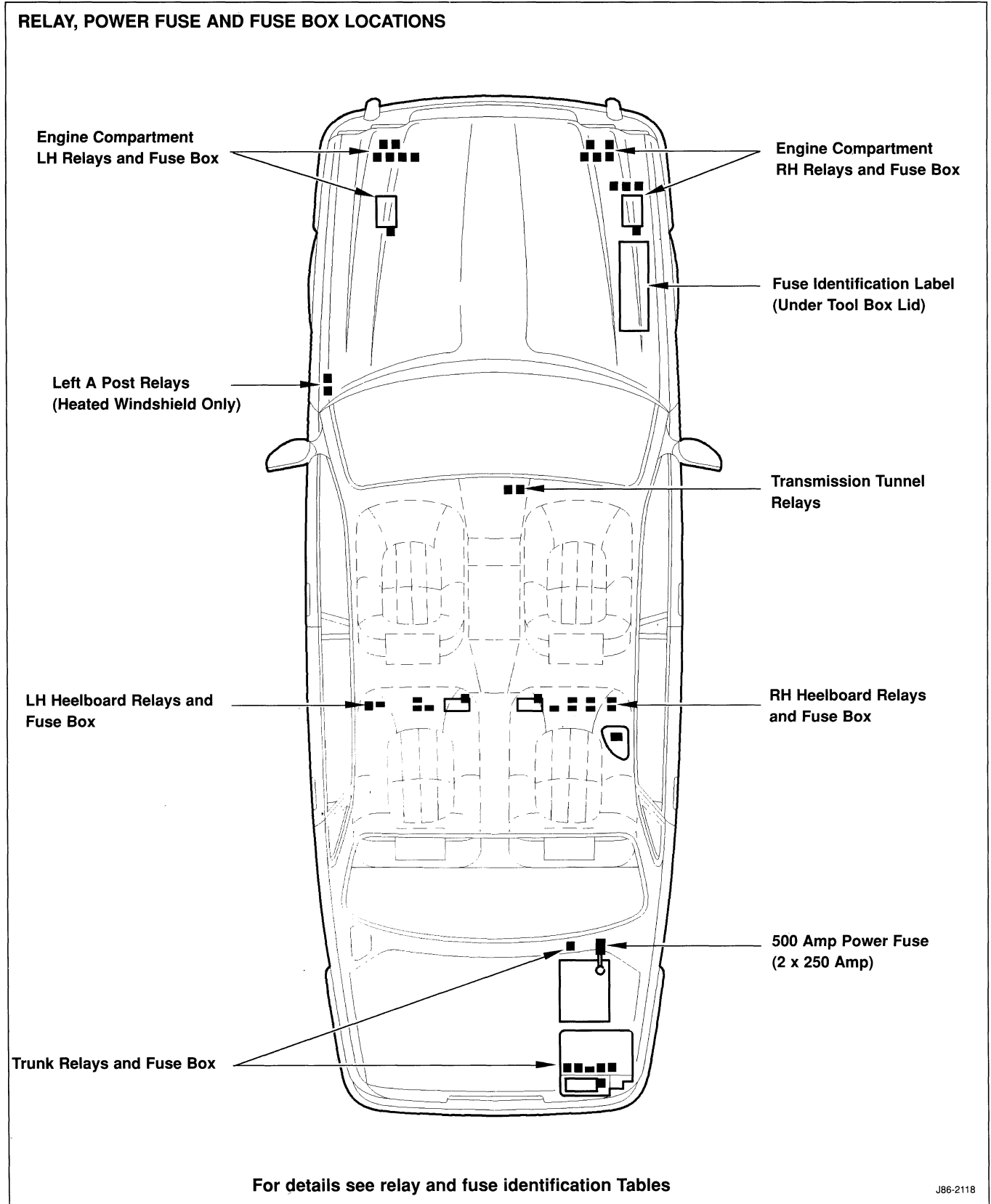

Relay Identification Tables

Note:

In the engine compartment, if a relay is not required on a particular model variant it is replaced by a dummy relay. Dummy relays have a black case with a white stripe.

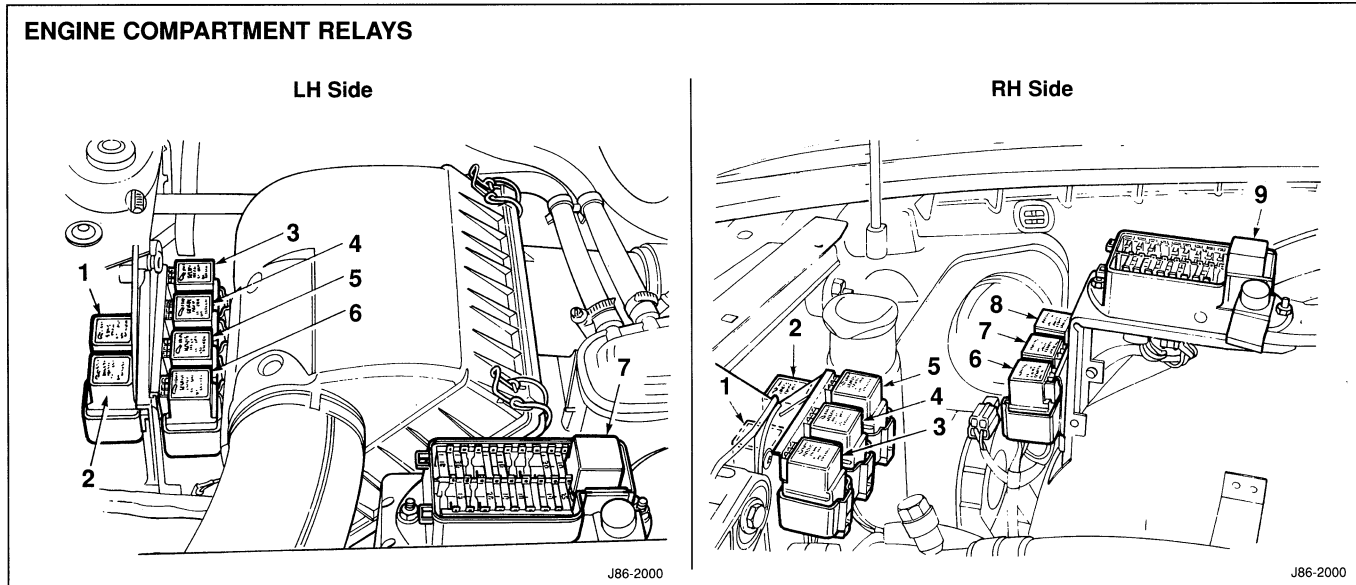

Location/ Number	Relay	Color		
		Case	Base	
Engine Compartment LH Side				
1	Front fog lamps	Black	Black	
2	LH dipped beam	Black	Black	
*	3	Air conditioning/heater coolant pump	Black	Black
*	4	Starter solenoid	Black	Black
*	5	Wiper motor ON/OFF	Black	Black
*	6	Wiper motor FAST/SLOW	Black	Black
	7	Horn	Blue	Black
Engine Compartment RH Side				
1	Main beam	Black	Black	
2	RH dipped beam	Black	Black	
3	Air conditioning clutch	Black	Black	
4	Secondary air injection control	Black	Black	
5	Engine management system control (AJ16 engine)	Black	Black	
	Fuel injection main (V12 engine)	Black	Black	
6	Ignition coil (V12 engine)	Black	Black	
7	Screen wash	Black	Black	
8	Headlamp power washers (where fitted)	Black	Black	
9	Ignition	Blue	Black	

* = Change from previous Technical Guide

HEELBOARD RELAYS

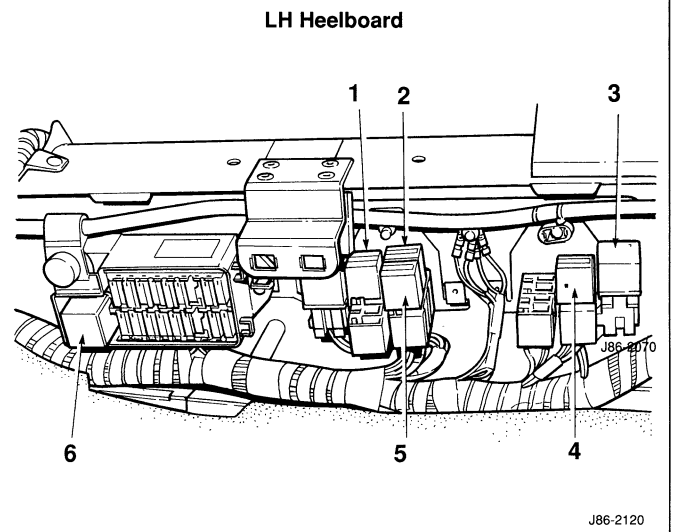
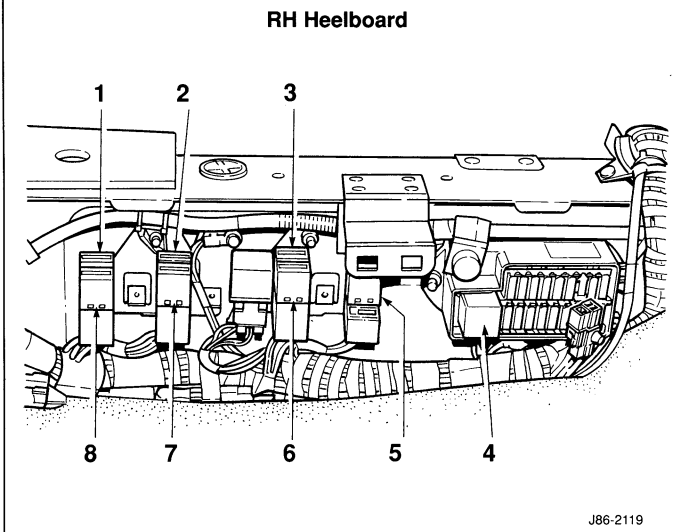

Location/ Number	Relay	Color	
		Case	Base
LH Heelboard			
1	Driver's side unlock	Black/Violet	Violet
2	Door lock	Black/Violet	Violet
3	Door courtesy/warning lamps	Blue	Yellow
4	Fuel filler flap lock	Black/Violet	Violet
5	Door unlock	Black/Violet	Violet
6	Ignition	Blue	Black
RH Heelboard			
1	LH air blower	Black/Blue	Blue
2	RH air blower	Black/Blue	Blue
3	Air conditioning isolator	Black/Blue	Blue
4	Ignition	Blue	Black
5	Door mirror heaters	Black/Blue	Blue
6	Cigar lighter	Black/Blue	Blue
7	RH high speed air blower	Black/Blue	Blue
8	LH high speed air blower	Black/Blue	Blue

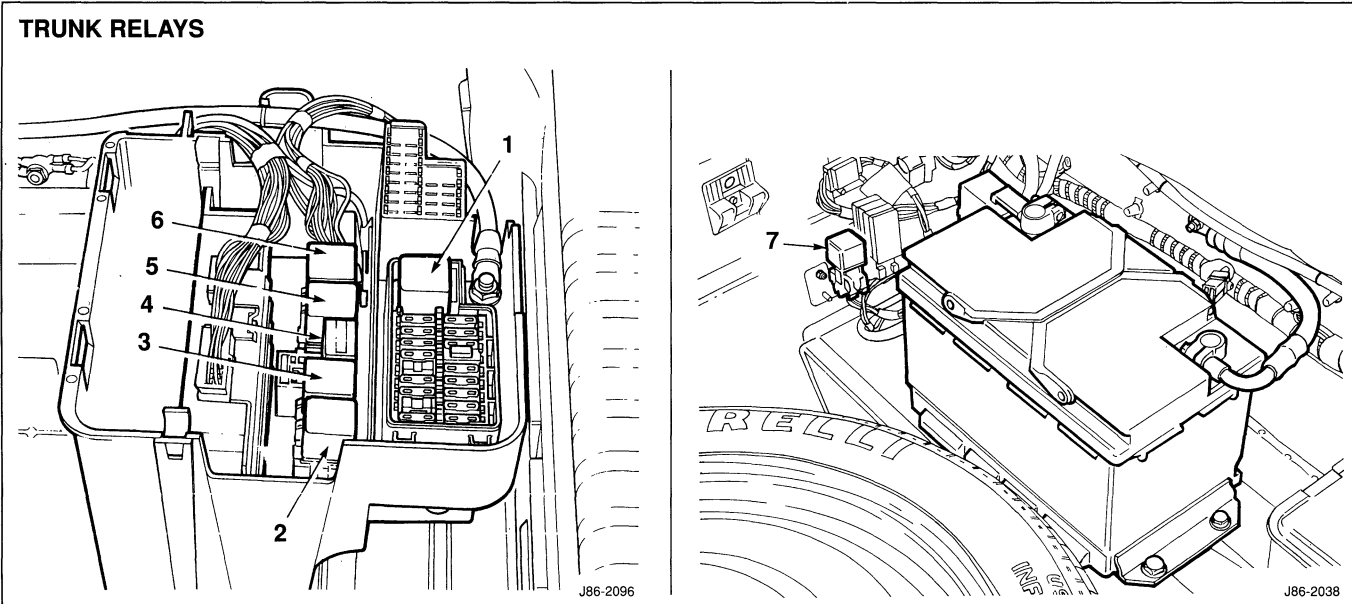

Location/ Number	Relay	Color	
		Case	Base
Trunk			
1	Auxiliary positive	Blue	Blue
* 2	Rear window heater	Blue	Yellow
* 3	Accessory (Dealer fitted option)	Blue	Black
* 4	Trunk release	Black/Violet	Violet
5	Fuel pump	Blue	Green
6	High mounted stop lamp	Blue	Red
7	Second fuel pump (V12 and supercharged AJ16 engines)	Blue	Yellow
Left A Post (Heated Windshields Only)			
1	Windshield RH heater	Blue	Black
2	Windshield LH heater	Blue	Black

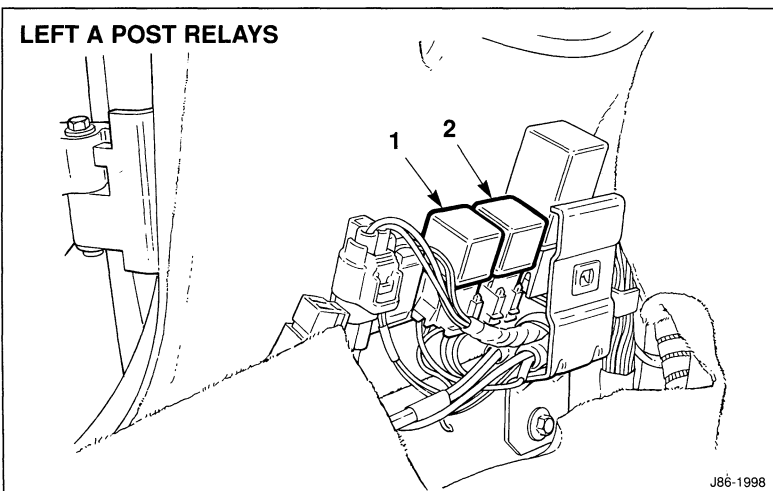

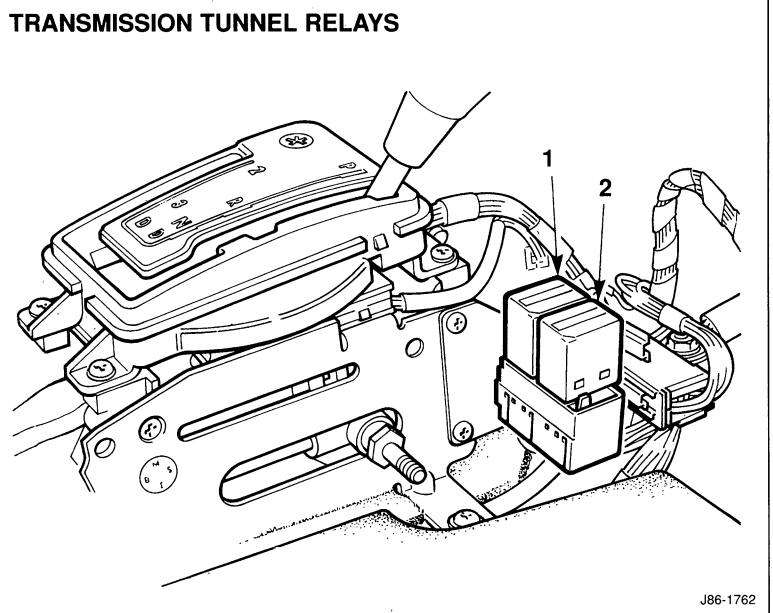

Location/ Number	Relay	Color	
		Case	Base
Transmission Tunnel			
1	Gearshift interlock	Black/Blue	Blue
2	Keylock	Black/Blue	Blue

Fuse Identification Table

Note:

Number 1 fuse is next to the input stud in all fuse boxes.

Fuse Box/ Number	Color	Rating (Amperes)	Circuit
Engine Compartment LH			
1	Natural	25	RH heated front screen (where fitted)
2	-	-	Not used
3	Natural	25	Starter solenoid
4	Red	10	LH dipped beam
5	Red	10	LH tail/LH license plate and front side lamps/LH front and rear side markers
6	Yellow	20	Wiper system
7	-	-	Not used
8	Blue	15	Coolant pump (air conditioning/heater)
9	-	-	Not used
10	Red	10	Horn 1
11	Green	30	Cooling fans (series/parallel)
12	-	-	Not used
13	-	-	Not used
14	Red	10	Horn 2
15	Natural	25	LH heated front screen (where fitted)
16	-	-	Not used
17	Green	30	Cooling fans (parallel)
18	Blue	15	Front fog lamps
Engine Compartment RH			
1	-	-	Not used
2	Blue	15	LH and RH main beam
3	-	-	Not used
4	Red	10	RH dipped beam
5	-	-	Not used
6	Tan	5	Engine management system electronic control module
7	Natural	25	Air pump (AJ16 engine, where fitted) Ignition coils (V12 engine)
8	Red	10	Air conditioning clutch/Security sounder
9	-	-	Not used
10	Tan	5	Ignition control, low current: Generator/Air conditioning clutch/Screen wash and headlamp power wash heaters and relays/Breather heater relay (AJ16 engine)
11	Yellow	20	Engine management system relay supply/Fuel injectors
12	Red	10	Engine management system/Starter relay/Ignition coil sensing/Air pump relay (AJ16 engine) - Fuel injection relay and engine management sensing (V12 engine)
13	Red	10	Screen wash pump
14	Red	10	Heated oxygen sensor heaters/Idle speed control valve
15	-	-	Not used
16	Red	10	Engine ancillaries (where fitted): Air pump control/Solenoid vacuum valve (V12 engine) Supercharger coolant pump (supercharged AJ16 engine)
17	Green	30	Headlamp power wash pump
18	Red	10	RH tail/RH license plate and front side lamps/RH front and rear side markers

Fuse Box/ Number	Color	Rating (Amperes)	Circuit
LH Heelboard			
1	Red	10	Rear fog lamps
2	Red	10	Heated door mirrors/Instrument illumination dimmer
3	Yellow	20	RH seat motors
4	Yellow	20	RH seat motors
5	Red	10	Instrument pack
6	Tan	5	Seat control modules/Low power door switch packs
7	Green	30	Anti-lock braking system pump (via control module)
8	Red	10	LH direction indicator lamps (front, side repeater and rear)
9	Yellow	20	Cigar lighters
10	Tan	5	Speed (cruise) control
11	Yellow	20	LH air conditioning blower motor
12	Tan	5	Instrument pack
13	Blue	15	Steering column electric power tilt/axial operation
14	Red	10	Automatic transmission, ignition supply
15	Green	30	LH window lift (front and rear)
16	Tan	5	Anti-lock braking system ignition supply
17	Red	10	Electrochromic mirror/Reversing lamps
18	Red	10	Air conditioning supply
RH Heelboard			
1	Blue	15	Central door locking/Dead locking (where fitted)
2	Tan	5	Gear shift interlock/Column control module/Center console switchpack/Exterior lighting switches/Mirror movement
3	Yellow	20	LH seat motors
4	Yellow	20	LH seat motors
5	Tan	5	Automatic transmission control module
6	Red	10	Stop lamps
7	Green	30	Anti-lock braking system control (via control module)
8	Red	10	Interior lights/Trunk lamps/Garage door opener (where fitted)
9	Natural	25	Seat heaters
10	Tan	5	Jaguar diagnostic system/Fuel pump relay coil
11	Yellow	20	RH air conditioning blower motor
12	Red	10	Air conditioning/Seat control modules/Mirror heaters relay/Power assisted steering
13	Red	10	RH direction indicator lamps (front, side repeater and rear)
14	Red	10	Mirrors/Heated rear window/Cigar lighter/Exterior lamps control module/High mounted stop lamp (where fitted)/Rear seat control (where fitted)
15	Green	30	RH window lift (front and rear)
16	Red	10	Wiper system/Front screen heaters/Coolant pump relay/Headlamp levelling (where fitted)/Clock
17	Blue	15	Air bags
18	Blue	15	Sunroof (where fitted)

Fuse Box/ Number	Color	Rating (Amperes)	Circuit
Trunk			
1	Natural	25	Power amplifier/Radio cassette and compact disc player (where fitted)
2	Tan	5	Mirror fold back
3	Yellow	20	Rear seat movement (where fitted)
4	Red	10	Security system
5	Red	10	Body processor unit
6	Red	10	Jaguar diagnostic system/Radio telephone (where fitted)
7	Green	30	Fuel pump
8	Blue	15	Trunk remote release/Antenna/Radio cassette and compact disc player memory supply
9	Yellow	20	Rear seat movement (where fitted)
10	Tan	5	Radio cassette and compact disc player control relay
11	Natural	25	Caravan (trailer) module
12	Tan	5	Accessories and telephone relay
13	Red	10	Accessories
14	Tan	5	Mirror fold back
15	Natural	25	Heated rear window
16	Tan	5	Air bag warning
17	Blue	15	Rear seat heaters (where fitted)
18	-	-	Not used

Control Modules

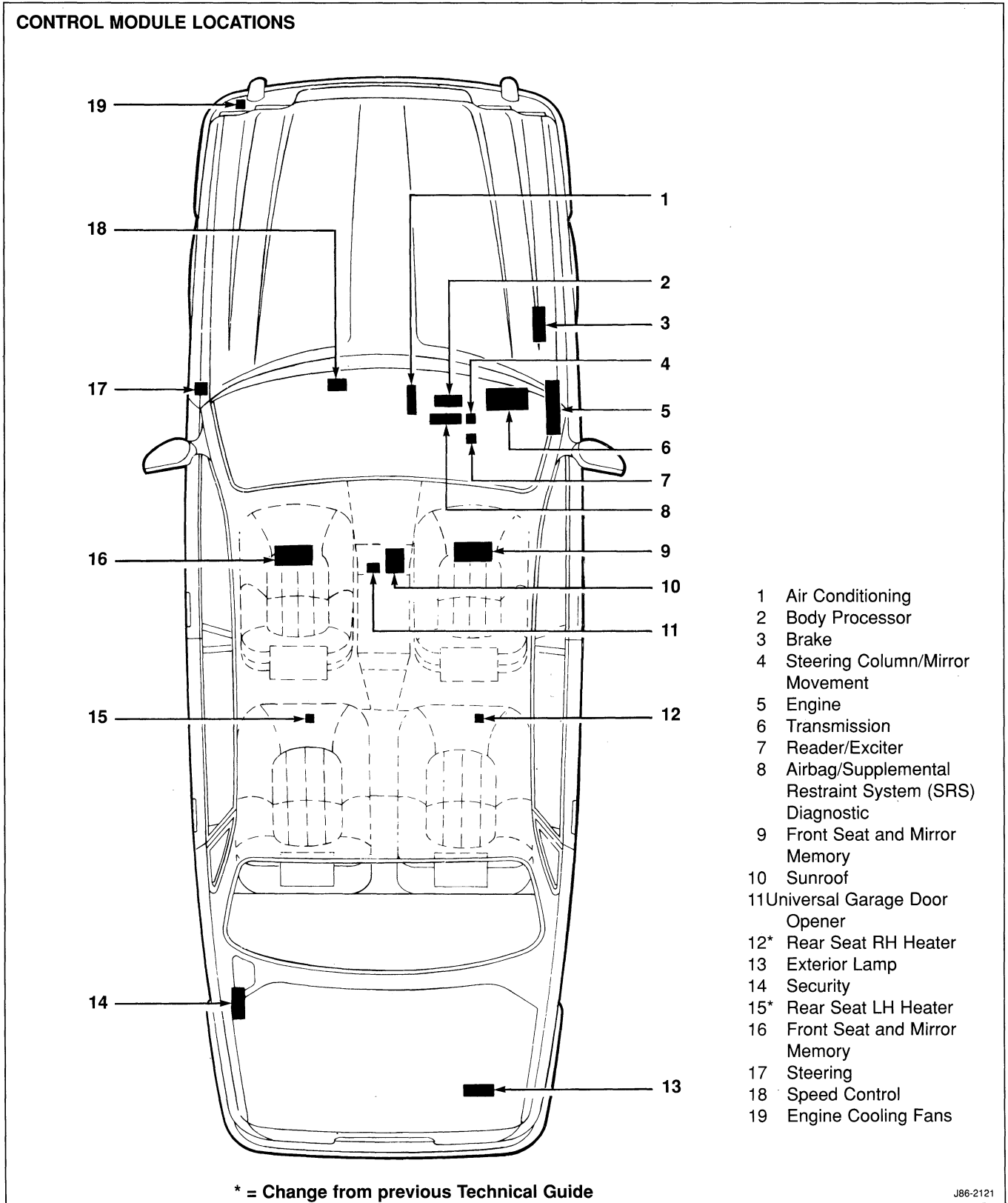

Engine Control Module

On VDP and XJ12 models, new software is incorporated in the engine control module. On the VDP, the new software affects both engine management and on-board diagnostics. On the XJ12, the new software affects only the on-board diagnostics.

VDP Engine Management

Transient Fueling

Transient fueling is revised to improve starting performance and to refine engine response to throttle movement.

Idle Speed Control

Load dependent idle speed in drive/reverse is introduced. If low battery voltage is detected the idle speed setting in drive/reverse is increased to 680 RPM (from 580 RPM), to increase the output from the generator. The idle speed in park/neutral remains at 700 RPM.

VDP On-board Diagnostics

Diagnostic Trouble Codes (DTC)

The following new DTC are introduced:

- P0111 Intake air temperature circuit range/performance
- P0121 Throttle position circuit range/performance
- P0461 Fuel level input circuit range/performance
- P0462 Fuel level input circuit malfunction (replaces P1199, fuel level sensor low input)
- P0560 System voltage malfunction

Malfunction Indicator Lamp (MIL)

The misfire diagnostics are revised so that the MIL comes on when any of the following misfire 'status' DTC are logged:

- P0300 Random misfire detected
- P1313 Catalyst damage misfire detected, bank 1
- P1314 Catalyst damage misfire detected, bank 2
- P1316 Misfire excess emissions

XJ12 On-board Diagnostics

Diagnostic Trouble Codes (DTC)

The following new DTC are introduced:

- P0461 Fuel level input circuit range/performance
- P0462 Fuel level sensor low input (was P1199)
- P0463 Fuel level sensor high input (was P1198)

