

CONTROL MODULE PIN OUT INFORMATION

Fig. 03.1

BODY PROCESSOR MODULE

Pin	Description	Active	Inactive
I FC15-7	NEUTRAL SWITCH STATUS	GROUND (N)	B+ (P, R, D, 4, 3, 2)
D FC15-21	SERIAL COMMUNICATION – KEY TRANSPONDER	ENCODED COMMUNICATIONS	
D FC15-39	SECURITY ACKNOWLEDGE	ENCODED COMMUNICATIONS	
I FC15-41	STARTER ENGAGE REQUEST	GROUND (CRANKING)	B+
O FC15-73	STARTER RELAY ACTIVATE	GROUND (CRANKING)	B+
I FC15-80	BATTERY SUPPLY VOLTAGE	B+	B+
D FC15-92	ENCODED COMMUNICATIONS		

ENGINE CONTROL MODULE

Pin	Description	Active	Inactive
I EM81-12	PARK / NEUTRAL CONFIRMATION	B+ (P, N)	GROUND (R,D,4,3,2)
I EM82-2	ENGINE CRANK	GROUND (CRANKING)	
D EM82-15	OK TO START	ENCODED COMMUNICATIONS	
D EM82-16	SECURITY ACKNOWLEDGE	ENCODED COMMUNICATIONS	

KEY TRANSPONDER MODULE

Pin	Description	Active	Inactive
D FC22-9	SERIAL COMMUNICATION	ENCODED COMMUNICATIONS	
D FC22-11	SERIAL COMMUNICATION – BPM	ENCODED COMMUNICATIONS	
D FC22-16	OK TO START	ENCODED COMMUNICATIONS	
D FC22-17	SECURITY ACKNOWLEDGE	ENCODED COMMUNICATIONS	

COMPONENTS

Component	Connector / Type / Color	Location / Access
BATTERY	BT66 / BATTERY CABLE CLAMP BT67 / BATTERY CABLE CLAMP	TRUNK / BATTERY COVER
BODY PROCESSOR MODULE	FC15 / 14-WAY AMP EEEEC / GREY	BULKHEAD / BEHIND GLOVE BOX
ENGINE CONTROL MODULE	EM80 / 31-WAY AMP 403 / NATURAL EM81 / 24-WAY AMP 403 / NATURAL EM82 / 17-WAY AMP 403 / NATURAL EM83 / 28-WAY AMP 403 / NATURAL EM84 / 22-WAY AMP 403 / NATURAL EM85 / 12-WAY MULTILOCK 070 / WHITE	ENGINE COMPARTMENT / CONTROL MODULE ENCLOSURE
GENERATOR	AN1 / EYELET AN2 / EYELET ST4 / EYELET	ENGINE COMPARTMENT / RH FRONT
HIGH POWER PROTECTION MODULE	BT60 / EYELET BT61 / EYELET BT62 / EYELET BT63 / EYELET	TRUNK / ADJACENT TO BATTERY
IGNITION SWITCH	FC4 / 8-WAY MULTILOCK 070 / WHITE	STEERING COLUMN
KEY TRANSPONDER MODULE	FC22 / 20-WAY MULTILOCK 040 / GREEN	BELOW INSTRUMENT PACK
NEUTRAL SWITCH	CC21 / 3-WAY MULTILOCK 070 / GREY	GEAR SELECTOR ASSEMBLY / CENTER CONSOLE
REGULATOR (GENERATOR)	PI60 / 3-WAY SUMITOMO 92 / BLACK	ENGINE COMPARTMENT / RH FRONT
STARTER MOTOR	ST1 / EYELET ST2 / EYELET ST3 / EYELET	ENGINE COMPARTMENT / ENGINE BLOCK / RH SIDE
SUPPRESSION MODULE	AN3 / 3-WAY ECONOSEAL III LC / RED	ENGINE COMPARTMENT / RIGHT FRONT

RELAYS

Relay	Case Color	Connector / Color	Location / Access
STARTER RELAY	BROWN	EM50 / BROWN	CONTROL MODULE ENCLOSURE RELAYS / ENGINE COMPARTMENT

HARNESS-TO-HARNESS CONNECTORS

Connector	Type / Color	Location / Access
EM2	20-WAY MULTILOCK 070 / GREY	PASSENGER 'A' POST / LOWER 'A' POST FINISHER
EM3	18-WAY MULTILOCK 070 / WHITE	PASSENGER 'A' POST / LOWER 'A' POST FINISHER
EM60	2-WAY ECONOSEAL J2 / GREY	ENGINE COMPARTMENT / ADJACENT RH TO FALSE BULKHEAD
FC7	20-WAY MULTILOCK 070 / YELLOW	ABOVE DIMMER MODULE / COIN TRAY
PI1	57-WAY SUMITOMO TS090 / BLACK	ENGINE COMPARTMENT / BULKHEAD / REAR OF ENGINE
PI2	13-WAY ECONOSEAL III LC / BLACK	ENGINE COMPARTMENT / BRACKET ON TOP OF TRANSMISSION
ST5	EYELET	ENGINE COMPARTMENT / RH FALSE BULKHEAD
ST6	EYELET	ENGINE COMPARTMENT / RH FALSE BULKHEAD

GROUND

Ground	Location / Type
BT65	EYELET (SINGLE) – BATTERY GROUND STUD
CC3R	EYELET (PAIR) – RH FRONT BULKHEAD STUD / CABIN SIDE
FC17L	EYELET (PAIR) – EMS BULKHEAD GROUND STUD

FOR CONTROL MODULE PIN OUT INFORMATION, UNFOLD PAGE TO LEFT.

The following abbreviations are used to represent values for Control Module Pin-Out data

I	Input	SG	Sensor Ground	S	SCP Network	V	Voltage (DC)
O	Output	A	ACP Network	D	Serial and Encoded Data	Hz	Frequency
SS	Sensor Supply V	C	CAN (Network)	B+	Battery Voltage	kHz	Frequency x 1000

CAUTION: The information on this data page is furnished to aid the user in understanding circuit operation. THIS INFORMATION SHOULD BE USED FOR REFERENCE ONLY.

NOTE: The values listed are approximately those that can be expected at the control module connector pins with all circuit connections made and all components connected and fitted. "Active" means a load is applied or a switch is ON; "Inactive" means a load is not applied or a switch is OFF.

Refer to the front of this book for detailed information and illustrations regarding the location and identification of harnesses, relays, grounds, control modules and control module pins.

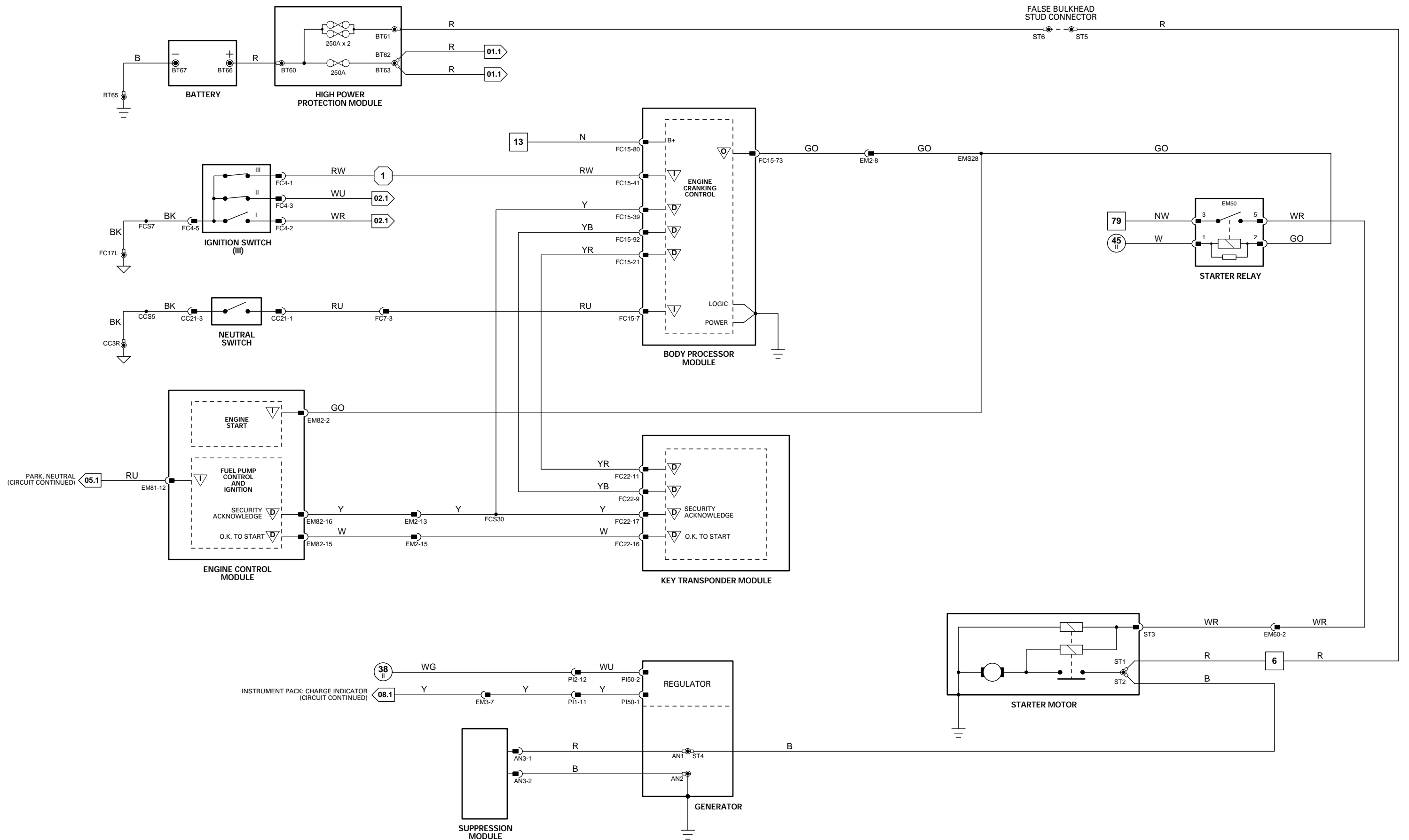

VARIANT: AJ27 N/A Vehicles
 VIN RANGE: F20645 →
 DATE OF ISSUE: September 2000

CONTROL MODULE PIN OUT INFORMATION

Fig. 03.2

BODY PROCESSOR MODULE

Pin	Description	Active	Inactive
I FC15-7	NEUTRAL SWITCH STATUS	GROUND (N)	B+ (P, R, D, 4, 3, 2)
D FC15-21	SERIAL COMMUNICATION – KEY TRANSPONDER	ENCODED COMMUNICATIONS	
D FC15-39	SECURITY ACKNOWLEDGE	ENCODED COMMUNICATIONS	
I FC15-41	STARTER ENGAGE REQUEST	GROUND (CRANKING)	B+
O FC15-73	STARTER RELAY ACTIVATE	GROUND (CRANKING)	B+
I FC15-80	BATTERY SUPPLY VOLTAGE	B+	
D FC15-92	ENCODED COMMUNICATIONS		

ENGINE CONTROL MODULE

Pin	Description	Active	Inactive
I EM81-12	PARK / NEUTRAL CONFIRMATION	B+ (P, N)	GROUND (R,D,4,3,2)
I EM82-2	ENGINE CRANK	GROUND (CRANKING)	
D EM82-15	OK TO START	ENCODED COMMUNICATIONS	
D EM82-16	SECURITY ACKNOWLEDGE	ENCODED COMMUNICATIONS	

KEY TRANSPONDER MODULE

Pin	Description	Active	Inactive
D FC22-9	SERIAL COMMUNICATION	ENCODED COMMUNICATIONS	
D FC22-11	SERIAL COMMUNICATION – BPM	ENCODED COMMUNICATIONS	
D FC22-16	OK TO START	ENCODED COMMUNICATIONS	
D FC22-17	SECURITY ACKNOWLEDGE	ENCODED COMMUNICATIONS	

DUAL LINEAR SWITCH

Pin	Description	Active	Inactive
I CC8-2	TCM / DUAL LINEAR SWITCH COMMON GROUND SUPPLY	GROUND	GROUND
O CC8-4	NEUTRAL SWITCH STATUS	GROUND (N)	B+ (P, R, D, 4, 3, 2)
O CC8-11	PARK / NEUTRAL CONFIRMATION	B+ (P, N)	GROUND (R, D, 4, 3, 2)

COMPONENTS

Component	Connector / Type / Color	Location / Access
BATTERY	BT66 / BATTERY CABLE CLAMP BT67 / BATTERY CABLE CLAMP	TRUNK / BATTERY COVER
BODY PROCESSOR MODULE DUAL LINEAR SWITCH ENGINE CONTROL MODULE	FC15 / 14-WAY AMP EEEEC / GREY CC8 / 12-WAY MULTILOCK 070 / GREY EM80 / 31-WAY AMP 403 / NATURAL EM81 / 24-WAY AMP 403 / NATURAL EM82 / 17-WAY AMP 403 / NATURAL EM83 / 28-WAY AMP 403 / NATURAL EM84 / 22-WAY AMP 403 / NATURAL EM85 / 12-WAY MULTILOCK 070 / WHITE	BULKHEAD / BEHIND GLOVE BOX RIGHT HAND SIDE OF GEAR SELECTOR / CENTER CONSOLE ENGINE COMPARTMENT / CONTROL MODULE ENCLOSURE
GENERATOR	AN1 / EYELET AN2 / EYELET ST4 / EYELET	ENGINE COMPARTMENT / RH FRONT
HIGH POWER PROTECTION MODULE	BT60 / EYELET BT61 / EYELET BT62 / EYELET BT63 / EYELET	TRUNK / ADJACENT TO BATTERY
IGNITION SWITCH KEY TRANSPONDER MODULE REGULATOR (GENERATOR) STARTER MOTOR	FC4 / 8-WAY MULTILOCK 070 / WHITE FC22 / 20-WAY MULTILOCK 040 / GREEN PI60 / 3-WAY SUMITOMO 92 / BLACK ST1 / EYELET ST2 / EYELET ST3 / EYELET	STEERING COLUMN BELOW INSTRUMENT PACK ENGINE COMPARTMENT / RH FRONT ENGINE COMPARTMENT / ENGINE BLOCK / RH SIDE
SUPPRESSION MODULE	AN3 / 3-WAY ECONOSEAL III LC / RED	ENGINE COMPARTMENT / RIGHT FRONT

RELAYS

Relay	Case Color	Connector / Color	Location / Access
STARTER RELAY	BROWN	EM50 / BROWN	CONTROL MODULE ENCLOSURE RELAYS / ENGINE COMPARTMENT

HARNESS-TO-HARNESS CONNECTORS

Connector	Type / Color	Location / Access
EM2	20-WAY MULTILOCK 070 / GREY	PASSENGER 'A' POST / LOWER 'A' POST FINISHER
EM3	18-WAY MULTILOCK 070 / WHITE	PASSENGER 'A' POST / LOWER 'A' POST FINISHER
EM60	2-WAY ECONOSEAL J2 / GREY	ENGINE COMPARTMENT / ADJACENT RH TO FALSE BULKHEAD
EM63	14-WAY MULTILOCK 070 / YELLOW	PASSENGER 'A' POST / LOWER 'A' POST FINISHER
FC7	20-WAY MULTILOCK 070 / YELLOW	ABOVE DIMMER MODULE / COIN TRAY
PI1	57-WAY SUMITOMO TS090 / BLACK	ENGINE COMPARTMENT / BULKHEAD / REAR OF ENGINE
PI2	13-WAY ECONOSEAL III LC / BLACK	ENGINE COMPARTMENT / BRACKET ON TOP OF TRANSMISSION
ST5	EYELET	ENGINE COMPARTMENT / RH FALSE BULKHEAD
ST6	EYELET	ENGINE COMPARTMENT / RH FALSE BULKHEAD

GROUND

Ground	Location / Type
BT65	EYELET (SINGLE) – BATTERY GROUND STUD
FC17L	EYELET (PAIR) – EMS BULKHEAD GROUND STUD
EM8R	EYELET (PAIR) – EMS LH GROUND STUD

FOR CONTROL MODULE PIN OUT INFORMATION, UNFOLD PAGE TO LEFT.

The following abbreviations are used to represent values for Control Module Pin-Out data

I	Input	SG	Sensor Ground	S	SCP Network	V	Voltage (DC)
O	Output	A	ACP Network	D	Serial and Encoded Data	Hz	Frequency
SS	Sensor Supply V	C	CAN (Network)	B+	Battery Voltage	KHz	Frequency x 1000

CAUTION: The information on this data page is furnished to aid the user in understanding circuit operation. THIS INFORMATION SHOULD BE USED FOR REFERENCE ONLY.

NOTE: The values listed are approximately those that can be expected at the control module connector pins with all circuit connections made and all components connected and fitted. "Active" means a load is applied or a switch is ON; "Inactive" means a load is not applied or a switch is OFF.

Refer to the front of this book for detailed information and illustrations regarding the location and identification of harnesses, relays, grounds, control modules and control module pins.

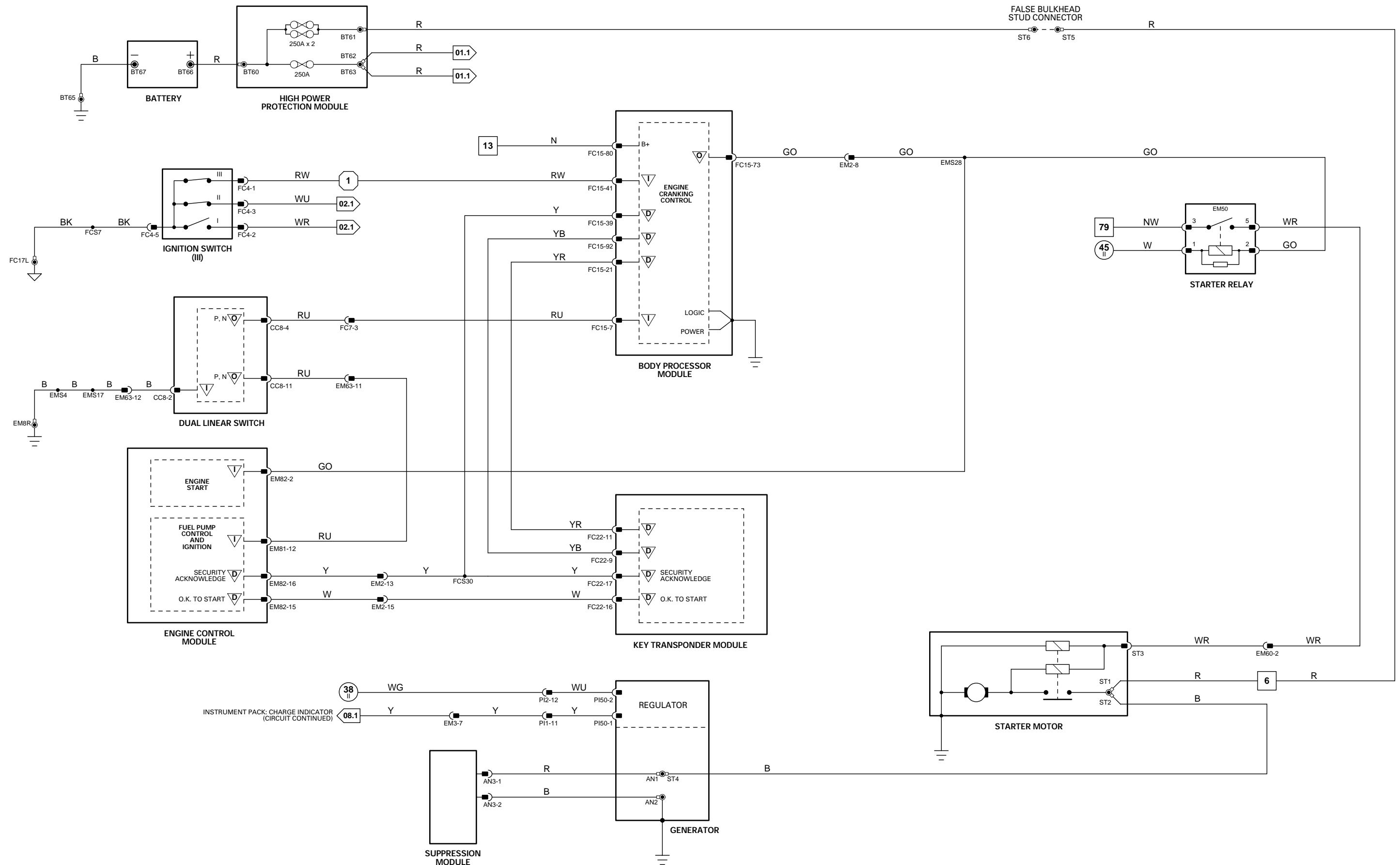

1 → 6 Fig. 01.1 1 → 4 Fig. 01.1 7 → 49 Fig. 01.2 50 → 88 Fig. 01.3 5 → 49 Fig. 01.4 50 → 63 Fig. 01.5 1 → 19 Fig. 02.1

▽ Input + Sensor Supply V ▽ ACP S SCP
 ▽ Output ▽ Sensor Ground ▽ CAN D Serial and Encoded Data

VARIANT: AJ27 SC Vehicles
 VIN RANGE: F20645 →
 DATE OF ISSUE: September 2000