

1998 XJ RANGE - Instrument Cluster - 413-01

Instrument Cluster 88.20.01

Removal

1. Adjust steering column to fully extended and lowered position.
2. Remove battery cover and disconnect ground cable from battery terminal. Refer to <<86.15.19>>.
3. Remove veneer from instrument panel. Refer to <<76.47.24>>.

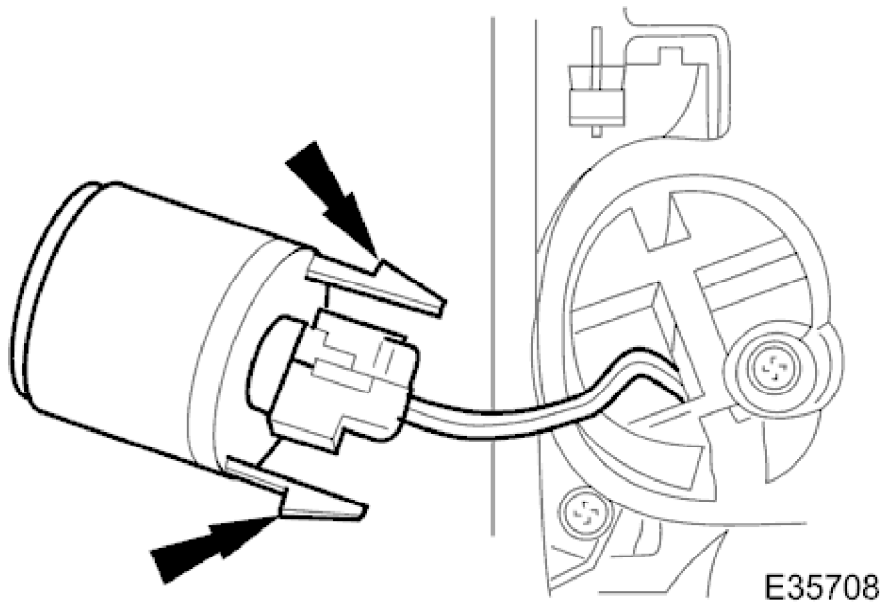

4. Using a small screwdriver, depress fog lamp switch upper retaining tang and release switch from gauge surround.

1998 XJ RANGE - Instrument Cluster - 413-01

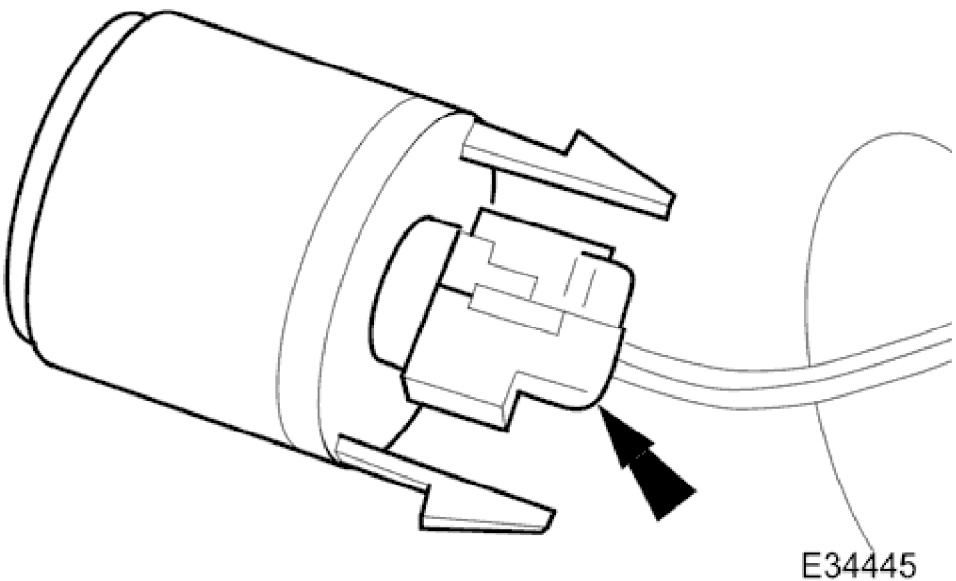

5. Position fog lamp switch for access, disconnect harness multiplug and remove switch.

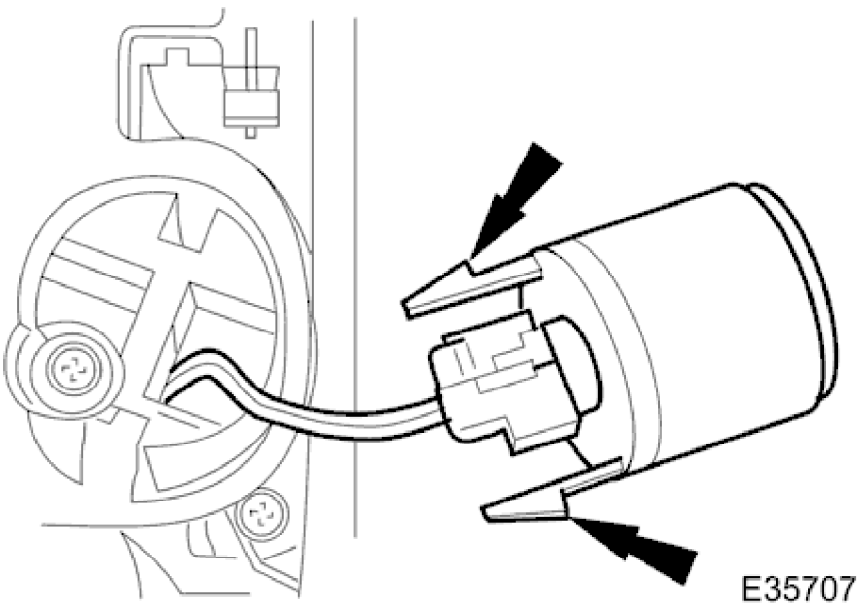

6. Using a small screwdriver, depress trip keyboard upper retaining tang and release keyboard from gauge surround.

1998 XJ RANGE - Instrument Cluster - 413-01

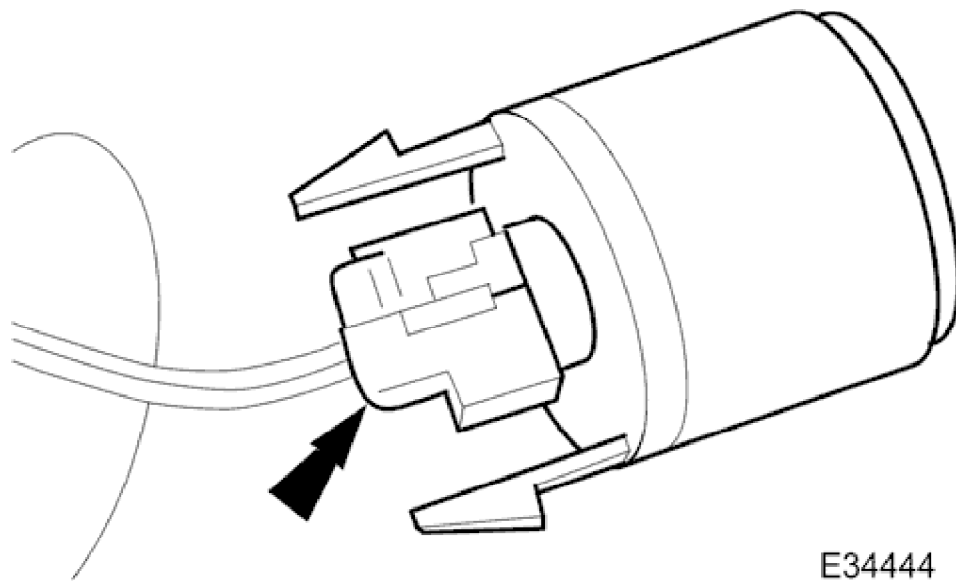

E34444

7. Position trip keyboard for access and disconnect harness multiplug.

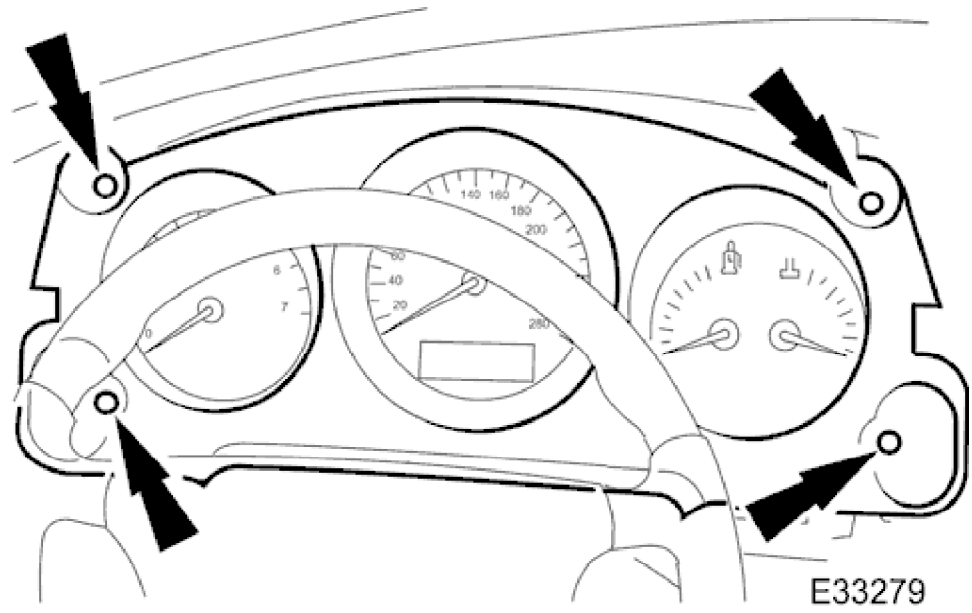

E33279

8. Slacken and remove four screws securing major gauge module/surround to fascia and withdraw surround.

1998 XJ RANGE - Instrument Cluster - 413-01

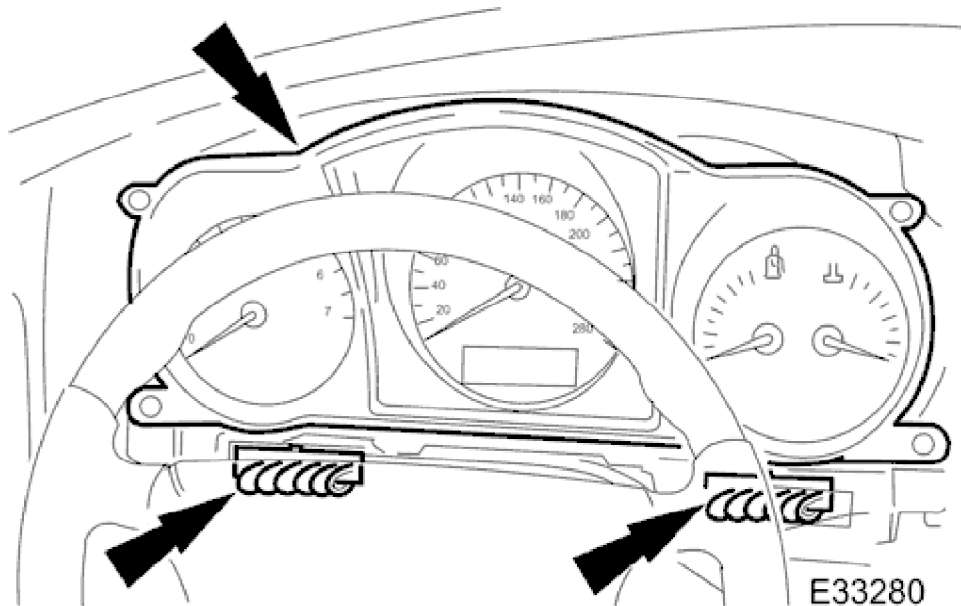

9. Withdraw major gauge module for access, disconnect the two harness multiplugs and remove gauge module from fascia.

Installation

1. Position major gauge module in fascia and connect both harness multiplugs.
2. Position major gauge surround on panel, routing harness multiplugs through apertures.
3. Fit and tighten screws securing major gauge module/surround to fascia.
4. Connect harness multiplug to trip keyboard and fit and fully seat keyboard in gauge surround, ensuring correct location of retaining tangs
5. Connect harness multiplug to fog lamp switch and fit and fully seat switch in gauge surround, ensuring correct location of tangs.
6. Fit veneer panel. Refer to <<76.47.24>>.
7. Connect ground cable to battery terminal and fit battery cover. Refer to <<86.15.15>>.
8. Return steering column to original position.