

External Controls

Introduction

Driver gearshift control is effected by:

- The gear shift lever.
- The accelerator pedal position.
- The kickdown switch (where fitted).
- The performance mode pushbutton.

Driver's Selector Module ('J' Gate)

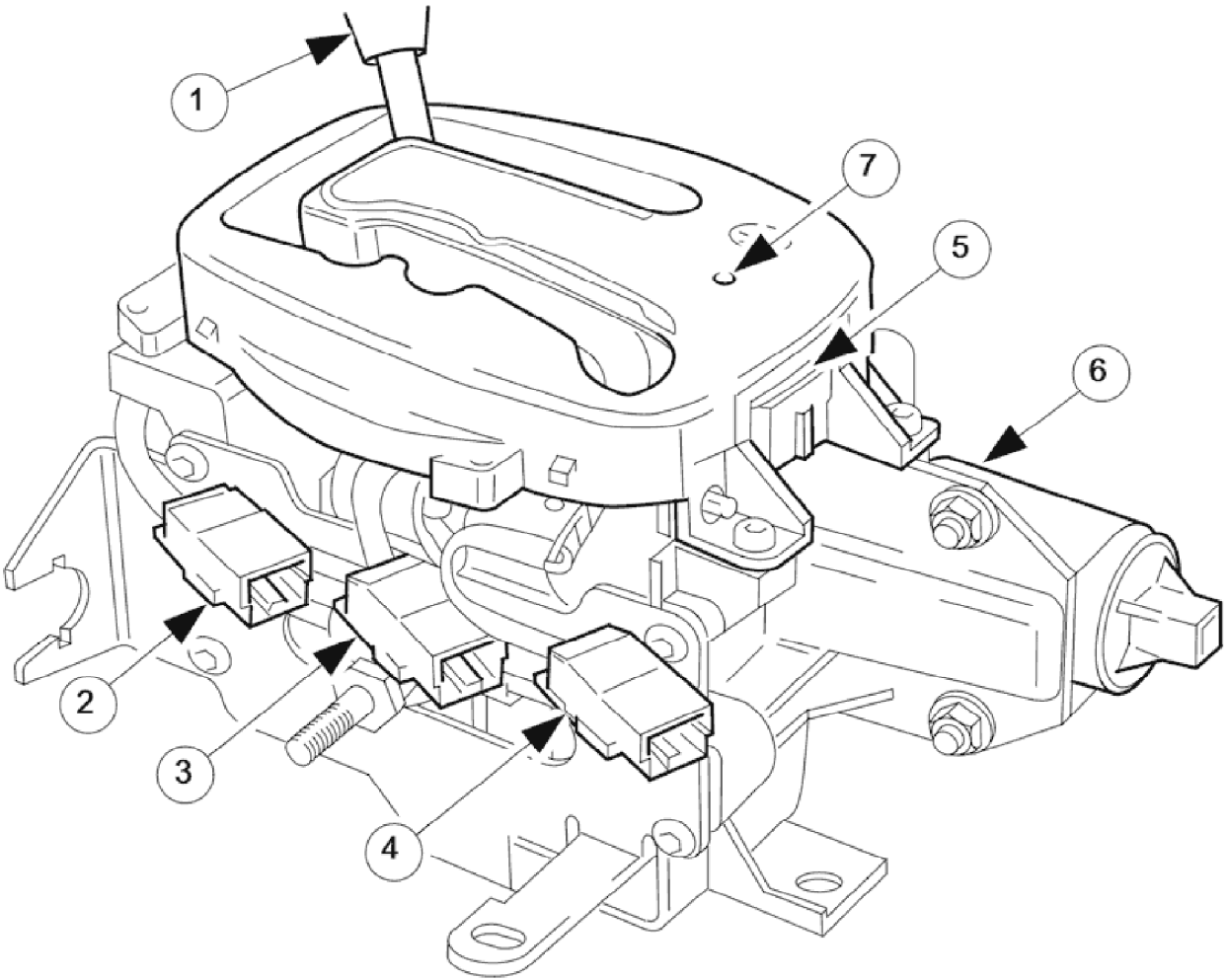

E33005

Item Description

1999 XJ RANGE - Automatic Transmission/Transaxle External Controls - Vehicles Without: S

1	Gear selector lever
2	Drive-to-fourth switch connector
3	Neutral position switch connector
4	Park position switch connector
5	Gear selector illumination module
6	Gear selector interlock solenoid
7	Security system Active LED

The gear selector lever:

- Has seven positions: Park, Reverse, Neutral, Drive, Fourth, Third and Second.
- Operates the transmission selector shaft and rotary switch, in all positions (except Drive-to-fourth) by means of a Bowden cable.
- Passes driver gearshift requests to the transmission control module via the rotary switch.

The Drive-to-fourth switch:

- Detects when the gear selector lever is moved from Drive to Fourth.
- Is hard-wired to the transmission control module.

The Neutral position switch:

- Is hard-wired to the body processor module.
- Detects when the gear selector lever is moved to the Neutral position.

The Park position switch:

- Is hard-wired to the body processor module.
- Detects when the gear selector lever is moved to the Park position.

The gear selector module:

- Provides illumination of the gear selector surround, which is dimmable via a CAN signal from the instrument cluster.
- Provides red illumination, on the gear selector surround, of the gear selected, by CAN signals from the instrument cluster.
- Illuminates the security system Active LED on the gear selector surround, in response to an input from the body processor module.
- Is connected to the fascia harness via a 12-way connector. Refer to Connector Pins Identification, <<307-01A>>.

The gear selector interlock solenoid:

- Prevents the gear selector lever from being moved from the Park position, unless the ignition switch is in position II, and the brake pedal is depressed.
- Is controlled by an input from the body processor module.

The seven gear selector positions are:

- P : The transmission is mechanically locked (starting available).
- R : Reverse gear.
- N : No power to the rear wheels (starting available).
- D : All 5 forward gears available.
- 4 : Upshift to 4th gear only.

1999 XJ RANGE - Automatic Transmission/Transaxle External Controls - Vehicles Without: S

- 3 : Upshift to 3rd gear only.
- 2 : Upshift to 2nd gear only.

Performance Mode Pushbutton

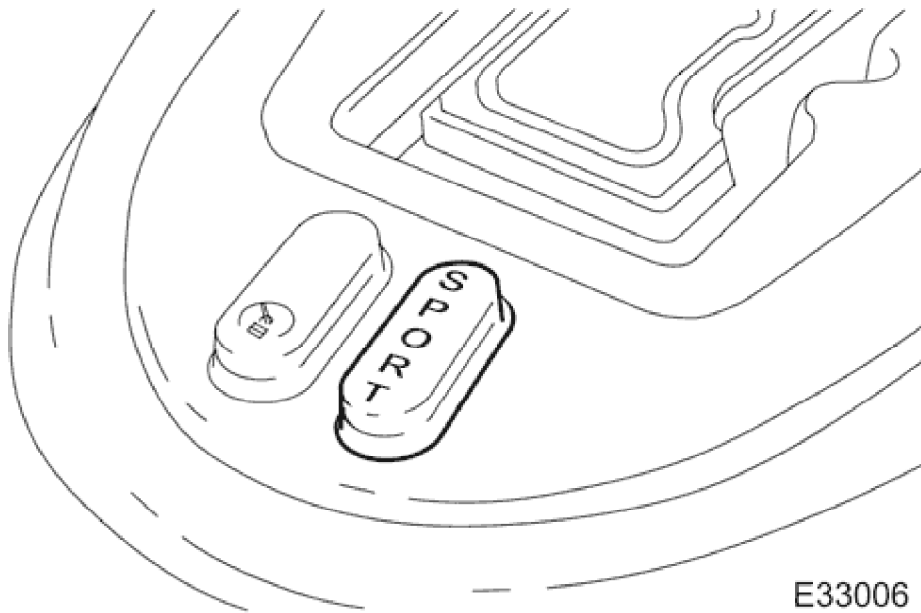

The performance mode pushbutton:

- Is mounted on the gear selector surround.
- Selects Normal or Sport mode when pressed by the driver.
- Is illuminated when Sport mode is selected.
- Is hard-wired to the transmission control module.

Kickdown Switch (where fitted)

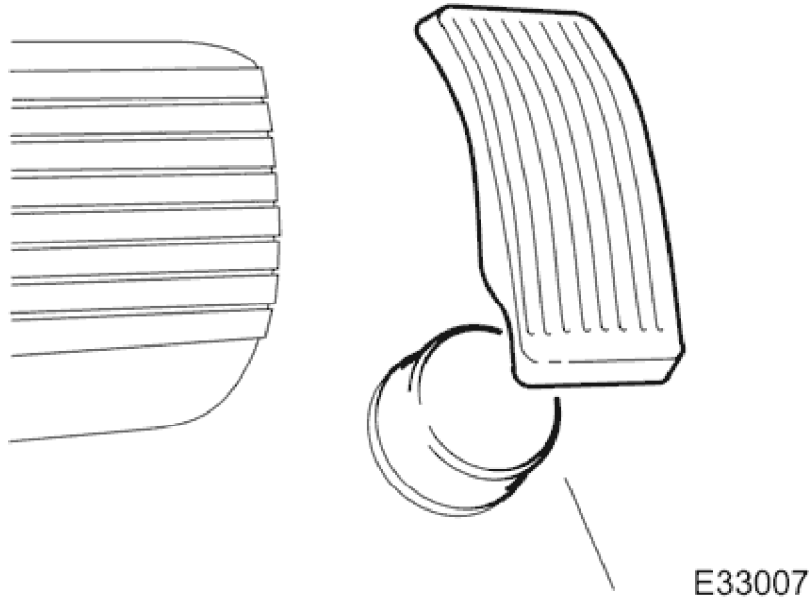

The kickdown switch:

- Is floor mounted under the accelerator pedal.
- Is operated by pressing the pedal to the full throttle position.
- Provides maximum acceleration on driver demand, by signalling the transmission control module to select the lowest gear to give maximum wheel torque.

Transmission Unit Gear Selector

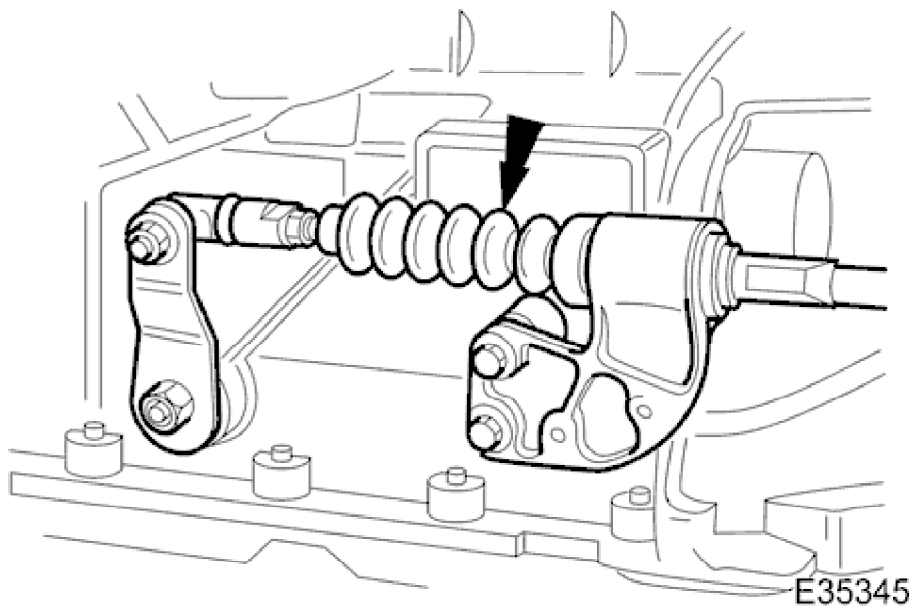

The gear selector at the transmission unit:

1999 XJ RANGE - Automatic Transmission/Transaxle External Controls - Vehicles Without: S

- Is connected to the driver's selector module by a Bowden cable.
- Operates the manual selector valve, which is part of the electro-hydraulic control unit.
- Operates the rotary switch, which is connected to the transmission control module.

Transmission Switches

Location, Rotary Switch

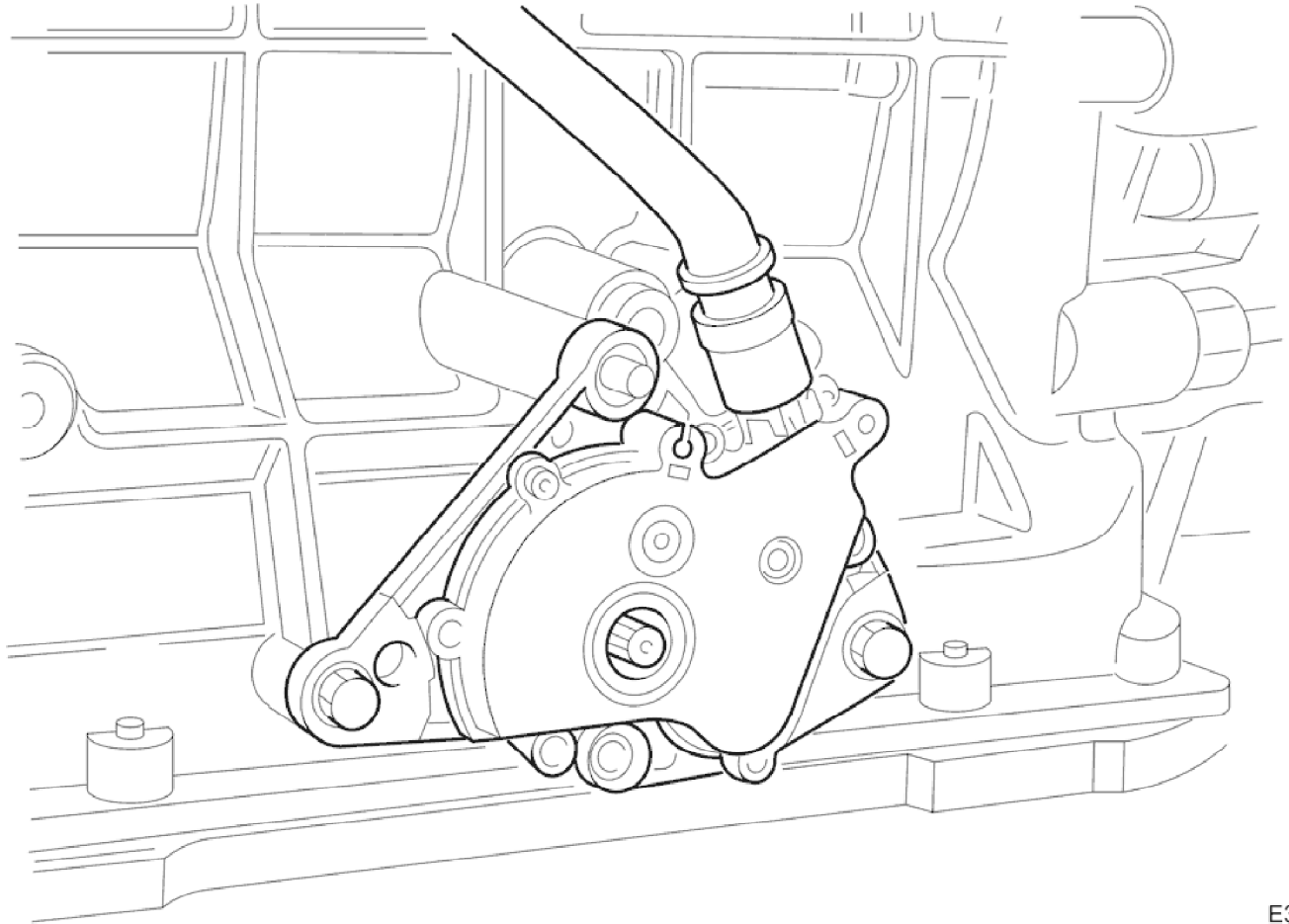

E35360

Location, Drive to 4th Switch

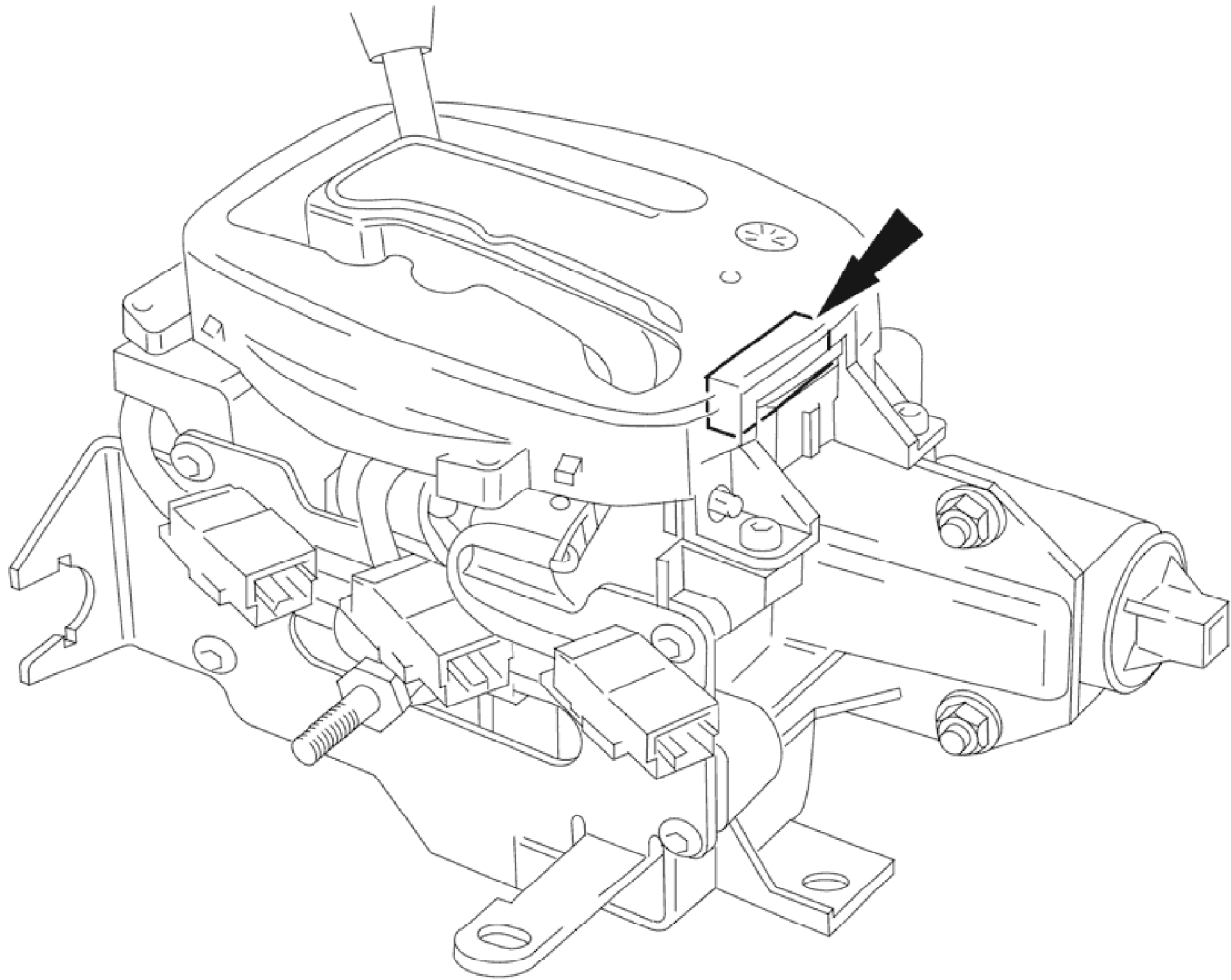

E33075

Operation

NOTE:

The rotary position switch is NOT adjustable.

The position of the gear selector lever is detected by the range sensor; a system which consists of two sensors (switch systems).

1. The rotary position switch, which is located on the RH side of the transmission case and is coaxial with the selector shaft.
2. The D to 4 (micro) switch, which is mounted in the 'J gate' assembly.

When the selector is moved across the gate to engage 4, or back from that side towards D the selector cable does not move. In order that this change of state be registered by the TCM the D to 4 switch is incorporated.

The rotary switch in isolation provides a 4-bit code, which, when added to the D to 4 switch becomes a 5-bit code. The TCM will make a failure judgement if it detects an 'illegal' code.

Circuit Diagram, Rotary and Drive to 4th Switches / TCM

1999 XJ RANGE - Automatic Transmission/Transaxle External Controls - Vehicles Without: S

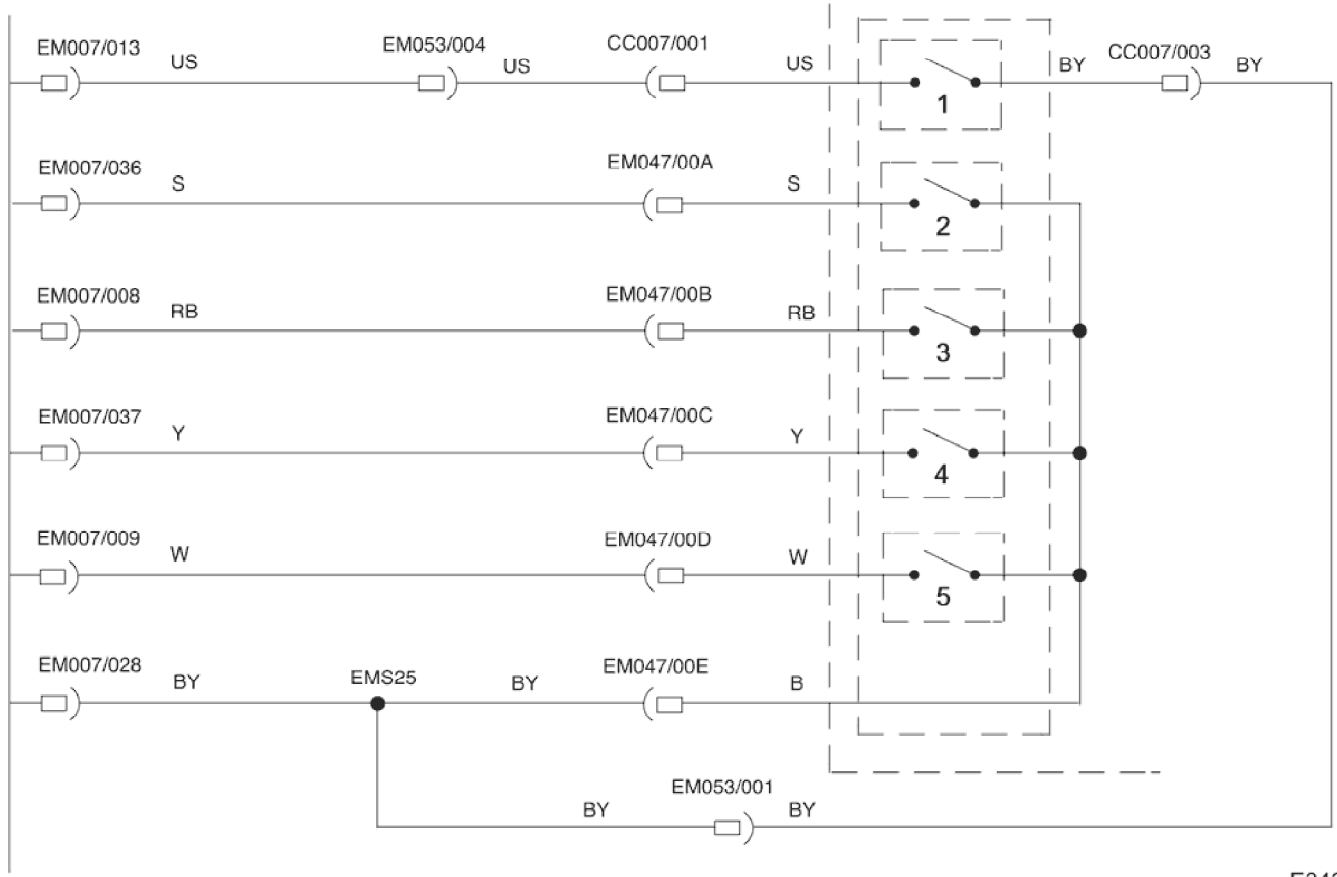

E34214

Item	Description
1	Drive to 4th switch
2	Switch L1
3	Switch L2
4	Switch L3
5	Switch L4