



V8 XJ Series/XK

DATE 12/02
Amended 07/03

303-S498

SERVICE

TECHNICAL BULLETIN

**“Engine Fail Safe” Displayed –
Replace Throttle Body – Normally Aspirated
Vehicles Only – Service Action S498**

MODEL
1999 MY XK8 Range
1999 MY V8 XJ Series

VIN
036938-042591
867156-878269

Remove and destroy Bulletin 303-S498, dated 12/02.
Replace with this Bulletin.
Redundant warranty information has been removed.

Issue:

As a result of investigations into throttle body failures, it has been revealed that a restriction of performance to the engine control system can potentially occur due to a manufacturing issue with one of the throttle body components. This will result in the Malfunction Indicator Lamp (MIL) being illuminated and the message ‘Engine Fail Safe’ being displayed on the message center.

Action:

On all 1999 XK8 and normally aspirated XJ8/VDP vehicles within the above VIN ranges, check the date code on the throttle body, at the next service opportunity.

If the date code is within the range 10T5 to 11T25, inclusive, replace the throttle body as described in the procedure on the next page.

If ‘Engine Fail Safe’ is displayed on the message center after the throttle body has been replaced, please refer to Technical Bulletin 303-58.

Throttle Body Replacement Procedure

1. Open hood and fit fender protectors.
2. Remove engine covers (Illustration 1).

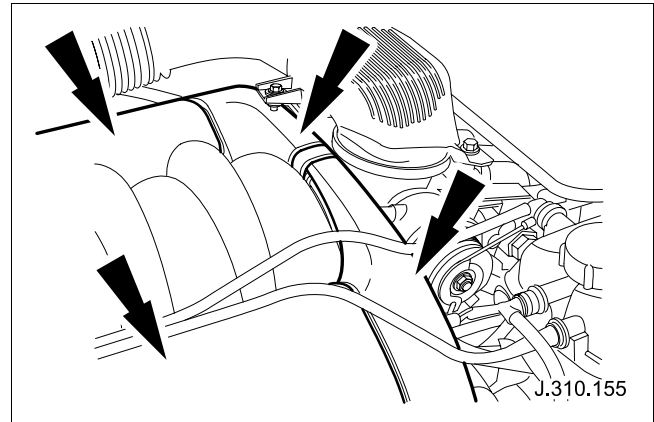

Illustration 1

3. Check date code of the throttle position sensor (Illustration 2).

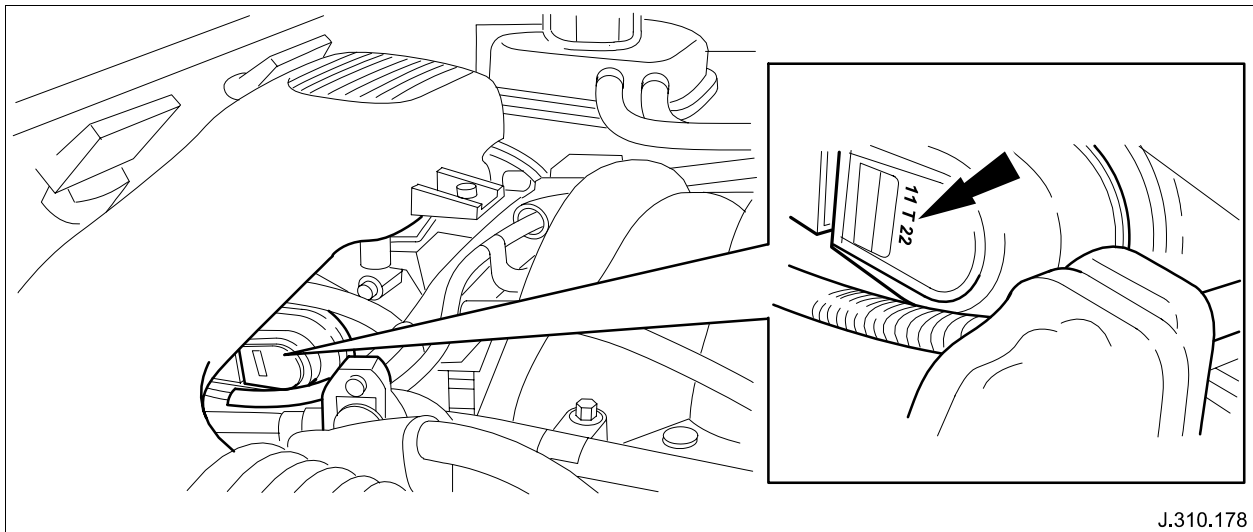

Illustration 2

Note: If the date code is within the range 10T5 to 11T25 inclusive, the throttle body must be replaced, proceed to step 4 of this workshop procedure. If the date code is not within the range 10T5 to 11T25 no further action is required. Proceed to step 34 of this workshop procedure.

4. Open luggage compartment lid and remove battery cover.
5. Disconnect battery. Refer to Technical Bulletin 414-01 before disconnecting the battery.
Warning: Never remove the coolant expansion tank pressure cap while the engine is running. When removing the cap use extreme care to avoid hot coolant or steam blowing out of the cooling system. Wait until the engine has cooled down then insulate the cap using a suitable cloth and slowly loosen the cap until the pressure is released. When all the pressure has been released slowly remove the cap from the tank. Failure to follow this instruction may result in personal injury.
6. Release the cooling system pressure.

7. Remove the air intake tube/mass airflow sensor/air cleaner cover assembly (Illustration 3).

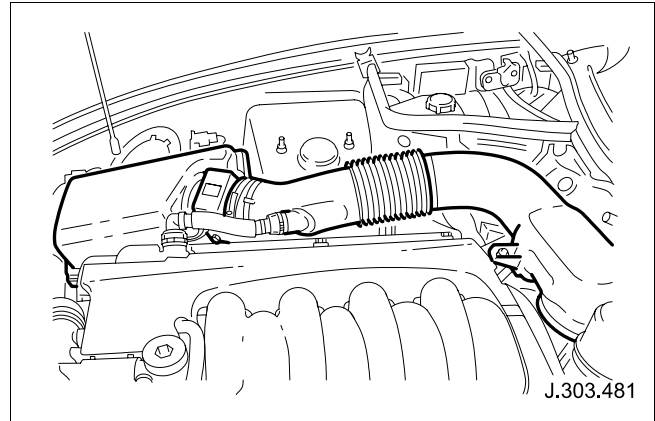

Illustration 3

8. Disconnect the throttle body electrical connectors (Illustration 4).

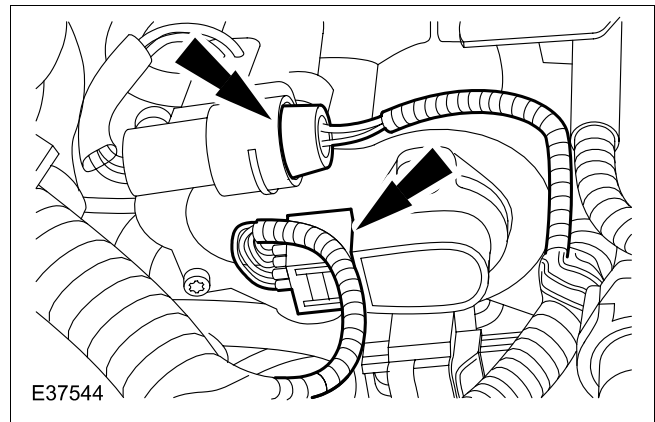

Illustration 4

9. Detach the right-hand camshaft position sensor wiring harness (Illustration 5).

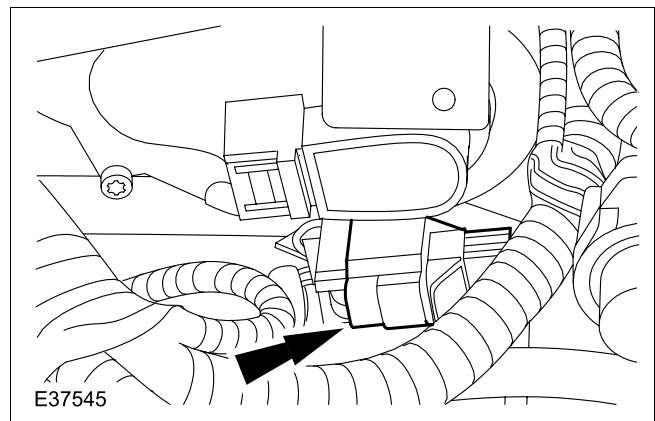

Illustration 5

10. Disconnect the throttle body coolant hose (Illustration 6).
Note: Cap the coolant hose to minimize coolant loss.

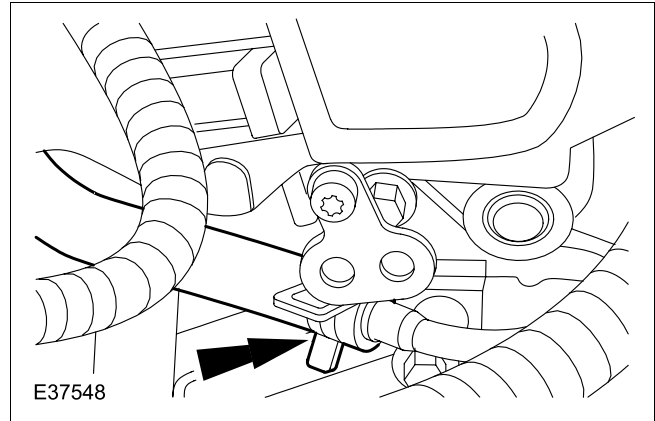

Illustration 6

11. Disconnect the throttle body coolant hose (Illustration 7).
Note: Cap the coolant hose to minimize coolant loss.

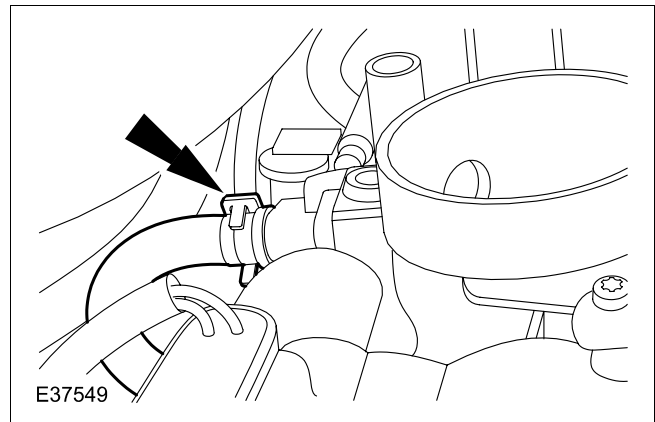

Illustration 7

12. Remove and discard the cable tie and disconnect the accelerator outer cable (Illustration 8).

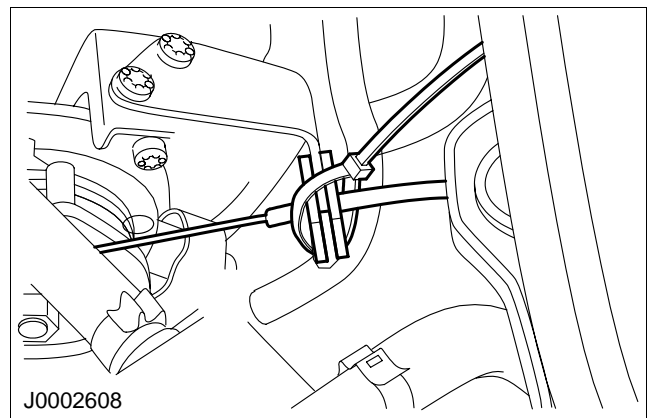

Illustration 8

13. Reposition the accelerator pulley to the full throttle position and disconnect the accelerator inner cable (Illustration 9).

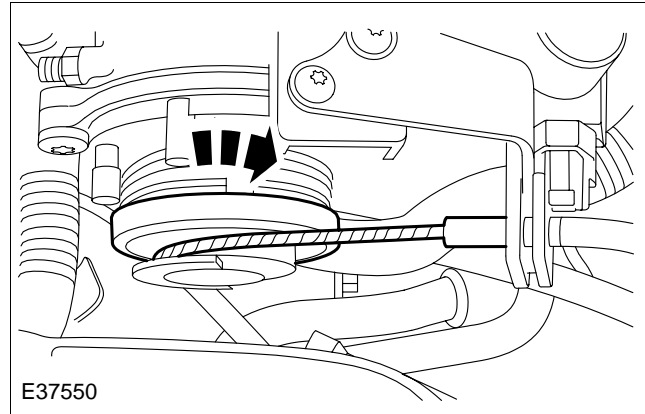

Illustration 9

14. Disconnect the throttle body electrical connectors (Illustration 10).

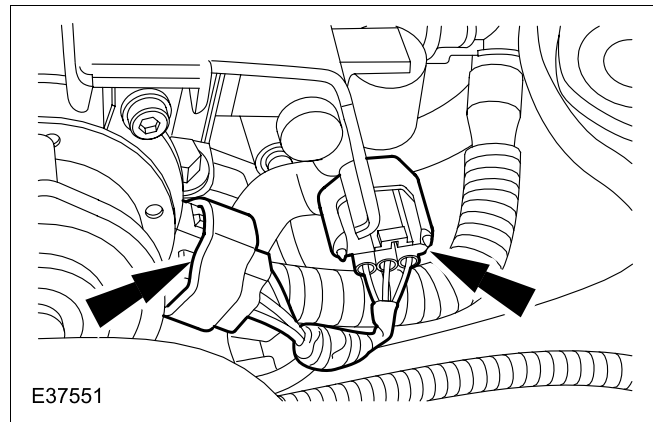

Illustration 10

15. Detach the left-hand camshaft position sensor wiring harness (Illustration 11).

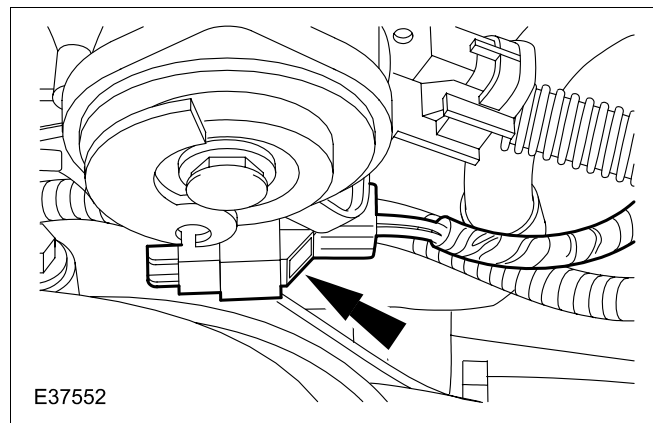

Illustration 11

16. Disconnect the air assist control valve hose (Illustration 12).

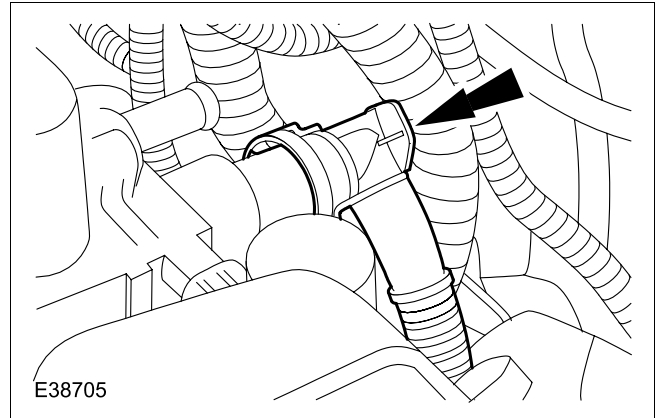

Illustration 12

17. Remove the throttle body securing screws and throttle body, and discard the gasket (Illustration 13).

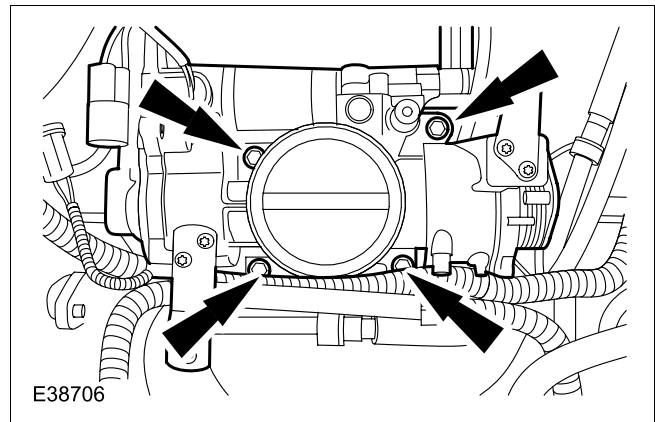

Illustration 13

18. Install a new throttle body gasket and throttle body. Tighten securing screws to 18-24 Nm (Illustration 14).

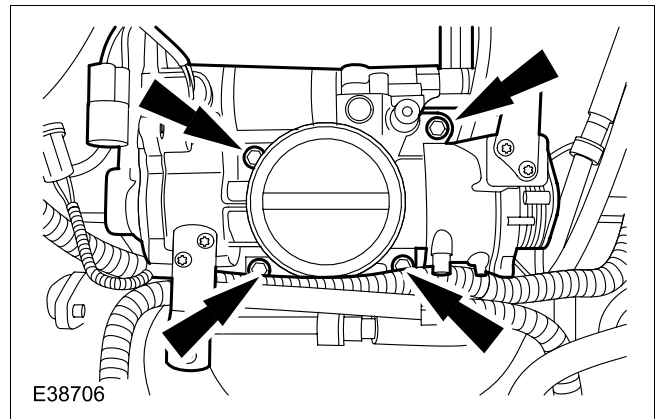

Illustration 14

19. Reconnect the air assist control valve hose (Illustration 15).

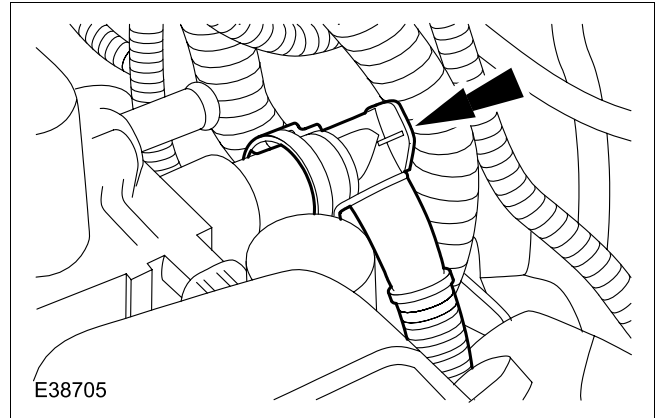

Illustration 15

20. Reinstall the left-hand camshaft position sensor wiring harness (Illustration 16).

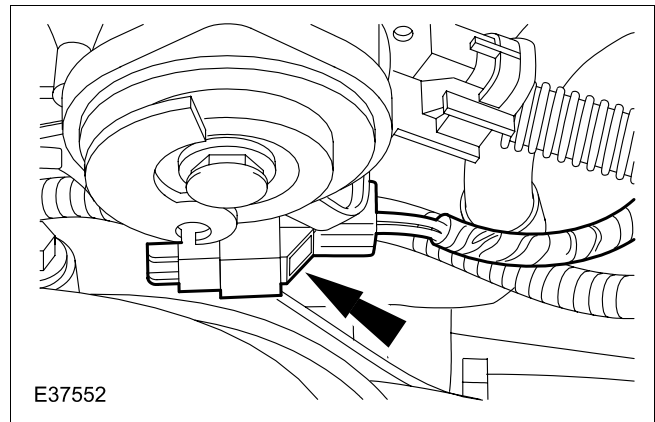

Illustration 16

21. Connect the throttle body electrical connectors (Illustration 17).

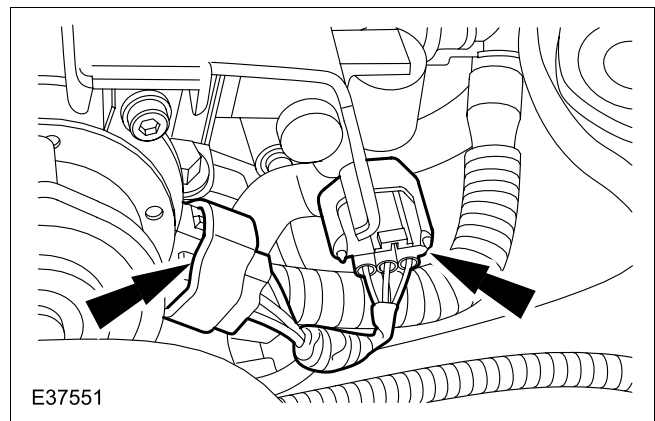

Illustration 17

22. Reposition the accelerator pulley to the full throttle position and connect the accelerator inner cable (Illustration 18).

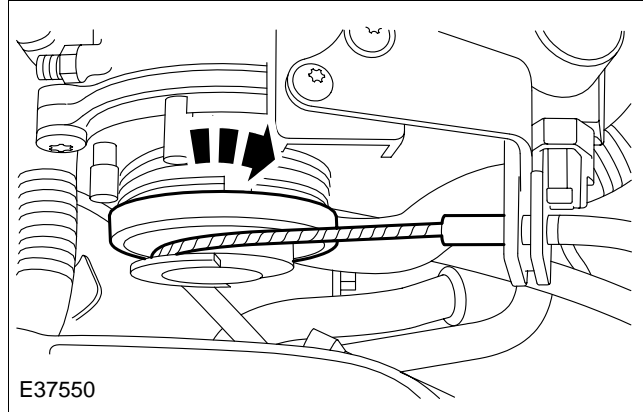

Illustration 18

23. Install accelerator outer cable to mounting bracket and secure using cable tie. (Illustration 19).

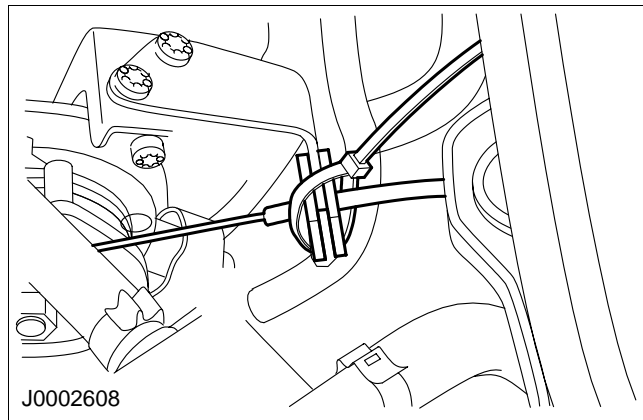

Illustration 19

24. Connect the throttle body coolant hose (Illustration 20).

Note: Uncap the coolant hose.

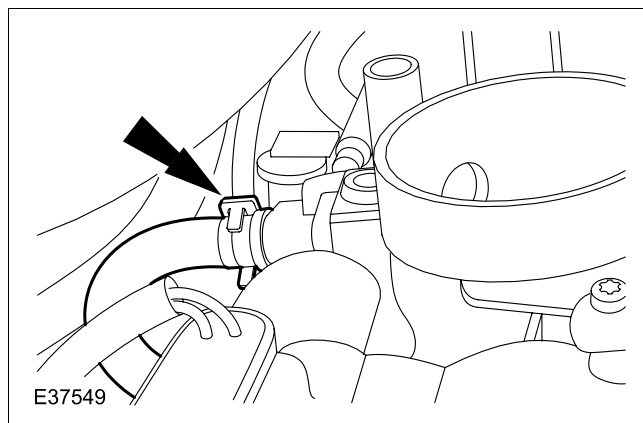

Illustration 20

25. Connect the throttle body coolant hose (Illustration 21).

Note: Uncap the coolant hose.

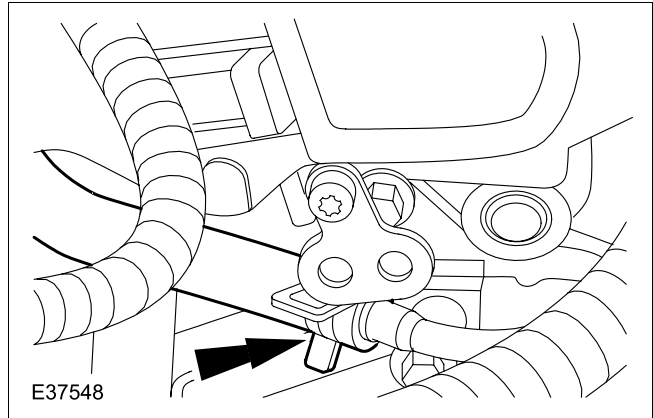

Illustration 21

26. Install the right-hand camshaft position sensor (Illustration 22).

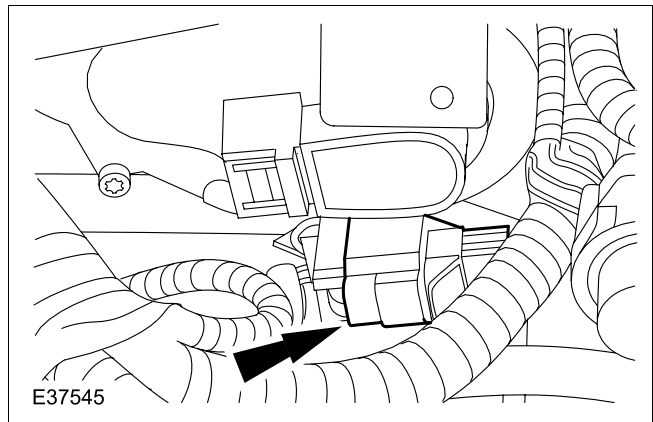

Illustration 22

27. Connect the throttle body electrical connectors (Illustration 23).

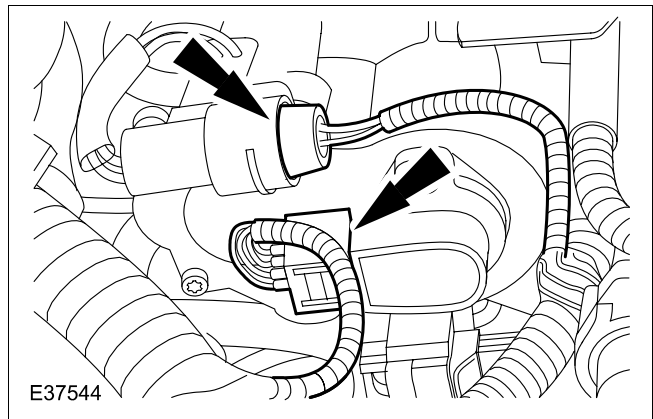

Illustration 23

28. Install the air intake/mass airflow sensor/air cleaner cover assembly (Illustration 24).

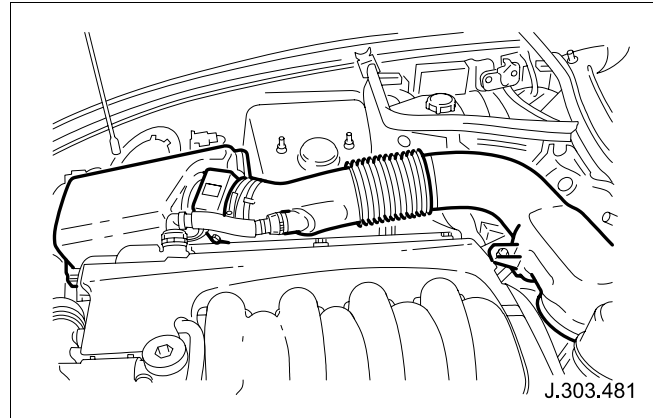

Illustration 24

29. Refill the cooling system to the correct level.
30. Install the cooling system expansion tank pressure cap.
31. Connect the battery (see Workshop Manual, JTIS CD ROM, section: 414-01).
32. Realign battery cover and close luggage compartment lid.
33. Check accelerator cable adjustment.
34. Record the date code from the original throttle position sensor for future reference.
35. Install engine covers (Illustration 25).

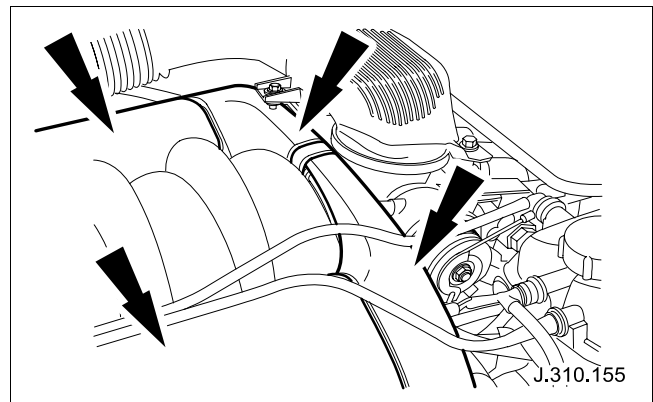

Illustration 25

36. Remove fender protectors and close hood.

Parts Information:

<u>DESCRIPTION</u>	<u>PART NUMBER</u>	<u>QTY</u>
Throttle Body	LNE 1560AE K	1
Throttle Body Gasket	NNE 3021AC	1
CableTie	ADU 9028	1

Note: Only the K suffix part number for the throttle body should be used for this campaign.

Warranty Information:

Warranty claims should be submitted quoting the information found in the table below. This will result in payment of the stated time and, where applicable, parts/miscellaneous expense codes.

The options that allow for drive in/drive out can only be claimed when the vehicle has been brought into the workshop for this action alone to be undertaken.

S498

1999 XK8 XC036938-XC042591

1999 XJ 8 XC867156-XC878269

Program Code	Option	Description	SRO	Time	Part Number	Part Description	Qty
S498	A	Check date code on throttle body	19.91.58	0.2			
S498	K	Check date code on throttle body	19.91.58	0.2			
		Drive in/drive out	10.10.10	0.1			
S498	B	Check date code and replace throttle body	19.91.59	0.8	LNE 1560AE K NNE 3021AC ADU 9028	Throttle body Throttle body gasket Cable tie	1 1 1
S498	C	Check date code and replace throttle body	19.91.59	0.8	LNE 1560AE K NNE 3021AC ADU 9028	Throttle body Throttle body gasket Cable tie	1 1 1
		Drive in/drive out	10.10.10	0.1			

