

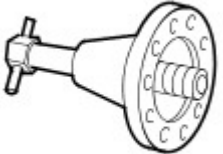

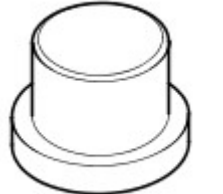
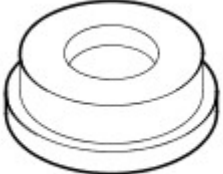

Rear Suspension - Rear Wheel Bearing

Removal and Installation

Special Tool(s)	
 E36458	Hub Holding Tool 204-195 (JD227)
 E36452	Hub Puller 204-011 (JD 1D)
 E36453	Rear-Hub Remover 204-113 (JD 132)
 E36455	Bearing Cup Replacer Adaptor 204-118 (JD 550-4/1)
 E36456	Bearing Cup Replacer Adaptor 204-118 (JD 550-4/2)
 E36457	Driver Handle 100-013 (18G-134)
 E36451	Rear-hub spacer replacer 204-003 (JD 15)
	Oil Seal Remover/Replacer

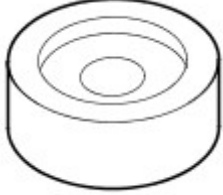
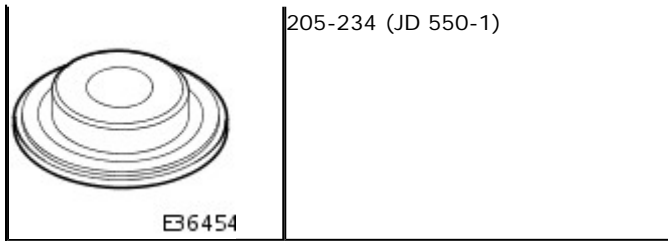

Removal

1.  **CAUTION:** Replacement of nuts and bolts: Various thread-locking devices are used on nuts and bolts throughout the vehicle. These devices restrict the number of times a nut or bolt can be used. See section 100-00 for information.

Release handbrake.

2. Raise the vehicle on a four-post lift.
3. Fully slacken but do not remove parking brake cable adjuster nut.

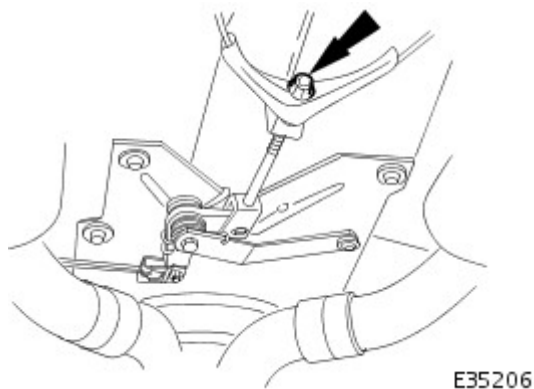

4. Release appropriate side parking brake cable from connecting clip.

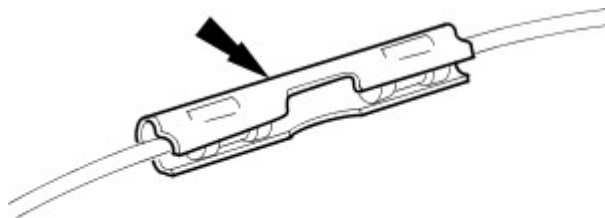

5. Withdraw parking brake cable through equalizer (LH side cable only).

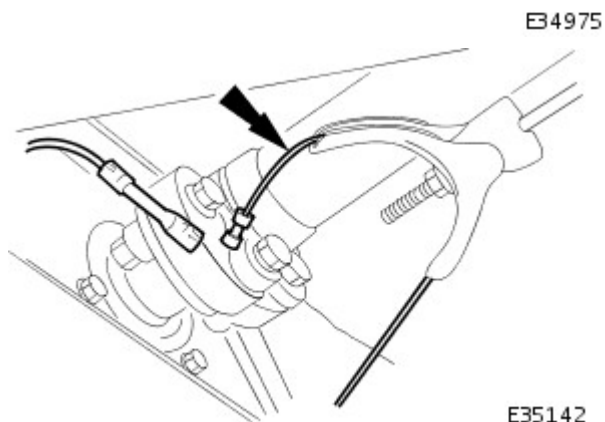

6. Lower four-post lift.
7. Raise rear of vehicle to working height and support on stands. Refer to section 100-02.
8. Remove rear wheel. Refer to section 204-04.

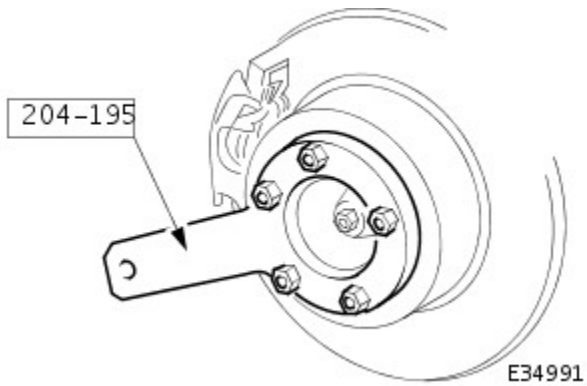

9. Position special tool 204-195 on hub studs and install securing nuts.

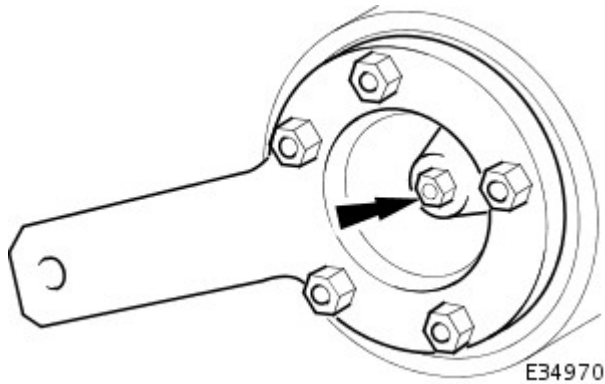

10. Slacken but do not remove hub to axle shaft securing nut.

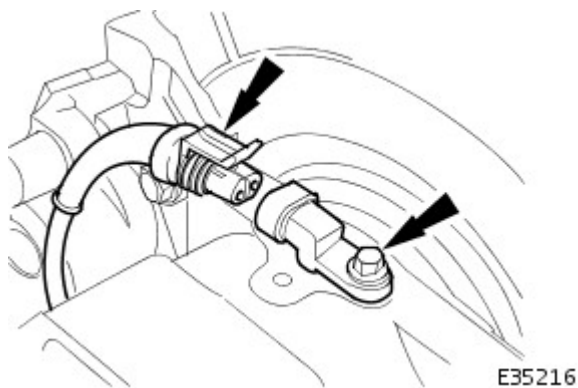

11. Remove securing nuts and withdraw special tool (204-195) from hub.

12. Remove rear brake disc. Refer to 70.10.13.

13. Remove parking brake shoes. Refer to 70.40.05.

14. Remove wheel speed sensor.

- Disconnect wheel speed sensor harness from sensor
- Remove wheel speed sensor securing bolt and withdraw sensor from hub carrier.

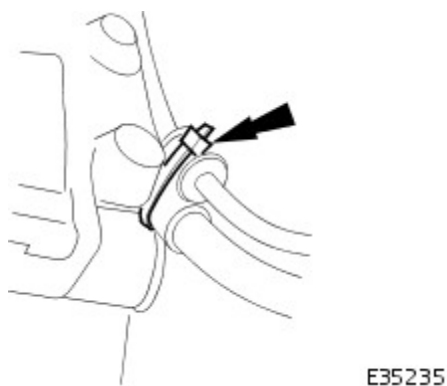

15. Sever and discard wheel speed sensor harness tie strap and position harness for access.

16. Remove hub nut and collar.

- Remove nut.

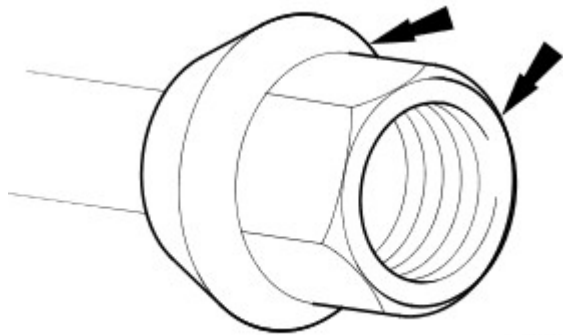

E34972

- Remove locating collar.



E34973

17. Install a thread protector on axle shaft.

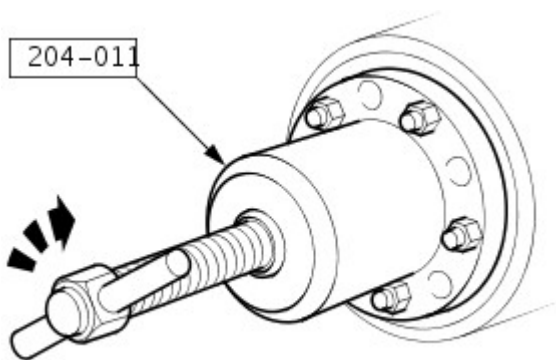

E34983

18. Release hub from axle shaft.

- Position hub puller 204-011 on hub studs.
- Install securing nuts.
- Progressively tighten puller center bolt to release hub from axle shaft splines.

19. Remove hub puller and thread protector.

- Remove securing nuts and release puller from hub.
- Remove thread protector from axle shaft.

20. Release parking brake cable from suspension mounting bracket.

- Remove cable retaining clip.
- Draw cable through suspension mounting bracket aperture.



E34999

21. Remove parking brake cable to hub carrier grommet.

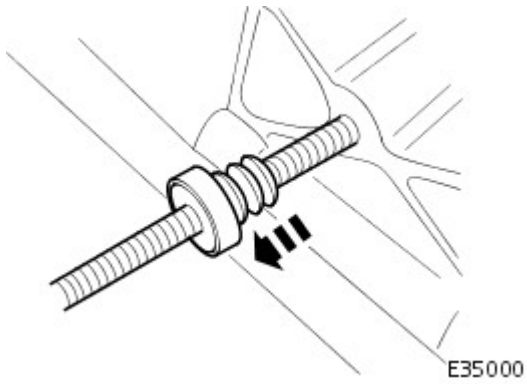

22. Remove back plate.

- Remove two bolts and two screws securing back plate to hub carrier.
- Withdraw back plate complete with parking brake cable.

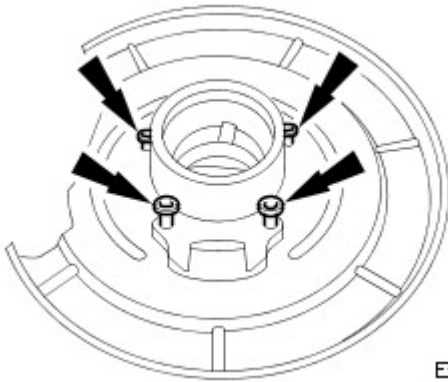

23. Mark wishbone at pivot pin eccentric flange marker to aid installation.

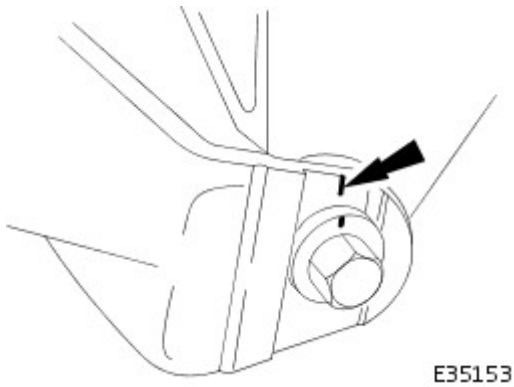

24. Remove nut and washer from pivot pin.

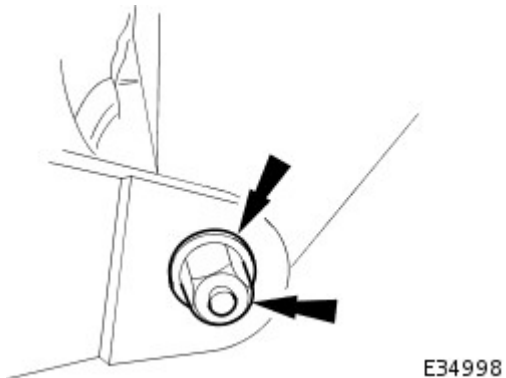

25. Remove hub and carrier from wishbone and axle shaft.

- Withdraw pivot pin and remove hub and carrier assembly.

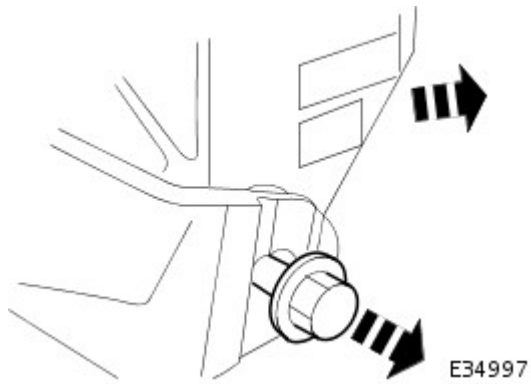

E34997

26.  CAUTION: Note position of shims during removal. They must be returned to their original positions during installation.

Noting positions, remove shim from each end of pivot pin sleeve.

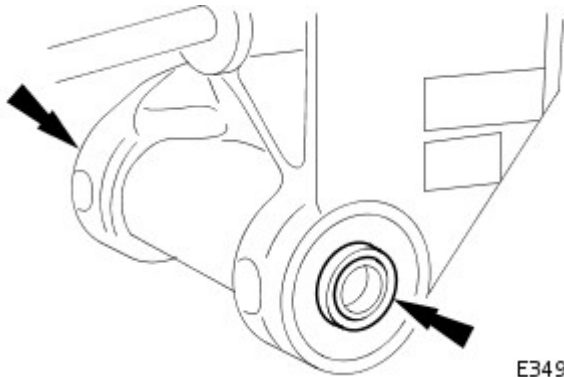

E34978

27. Withdraw pivot pin sleeve from hub carrier.

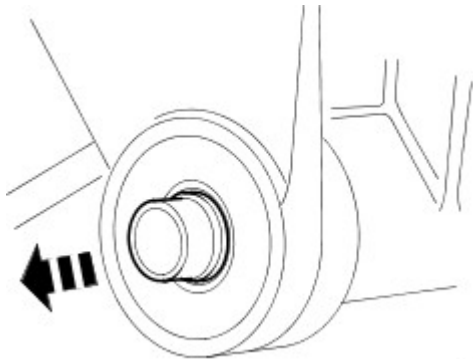

E34996

28. Using a hydraulic press, remove hub from carrier.

- Place large section of special tool 204-113 on press bed, with recess in tool uppermost.
- Position hub carrier on tool, ensuring handbrake cable housing locates in tool recess.
- Position small section of special tool on hub. 204-113.
- Align tool to press-ram, and operate press to remove hub from hub carrier.

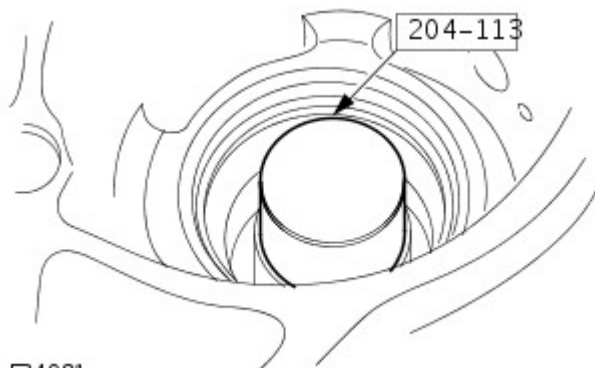

E34981

29. Place hub carrier on a work bench.

30. Withdraw ABS rotor from hub carrier.

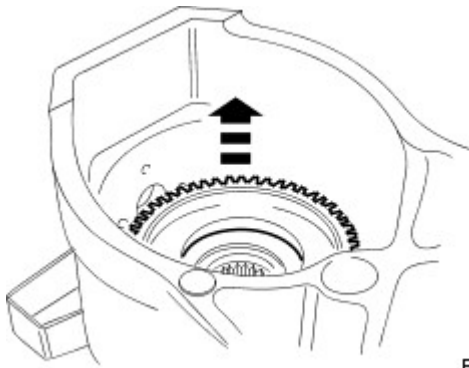

E34979

31. Remove outer seal and bearing assembly from hub carrier.

- Using a drift, remove and discard outer seal.
- Remove and discard outer bearing.
- Remove bearing spacer.
- Remove bearing shim.

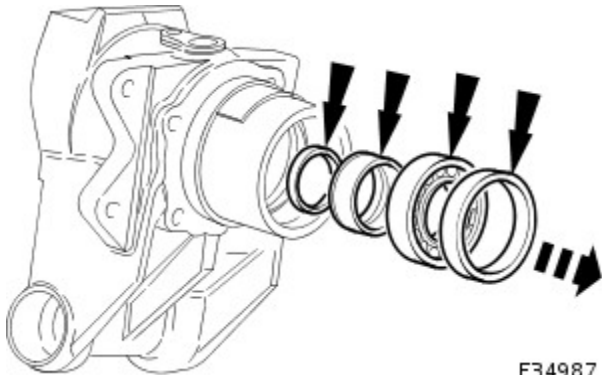

E34987

32. Remove inner seal and bearing from hub carrier.

- Using a drift, remove and discard inner seal.
- Remove and discard inner bearing.

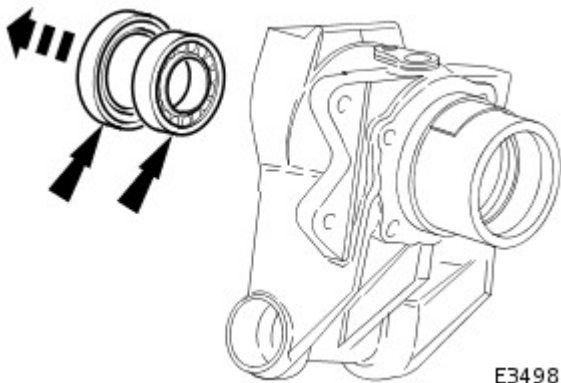

E34988

33. Remove inner bearing cup from hub carrier.

- Position hub carrier on a block of wood.
- Using a drift, remove and discard inner bearing cup.



E34982

34. Remove outer bearing cup from hub carrier.

- Position hub carrier on a block of wood.
- Using a drift, remove and discard outer bearing cup.

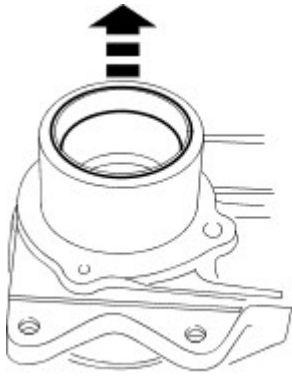

E34995

35. Clean hub and hub carrier.

Installation

1. Place hub carrier on press bed and insert inner bearing cup.

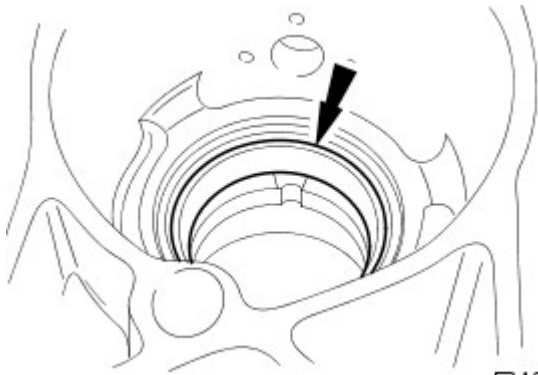

E34982

2. Using a hydraulic press, install new inner bearing cup in hub carrier.

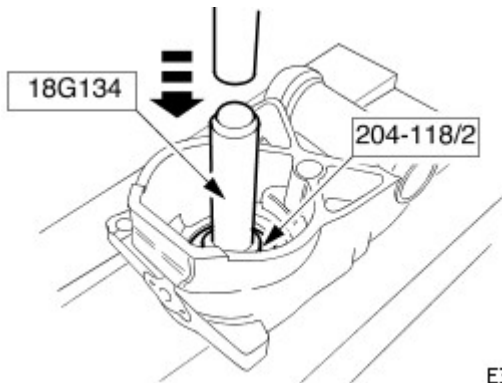

E35145

- Install special handle 18G134 to tool 204-118/2.
- Align special tool 204-118/2 to bearing cup.
- Align assembly to ram, and operate press to fully seat bearing cup.

3. Place hub carrier on press-bed and insert outer bearing cup.

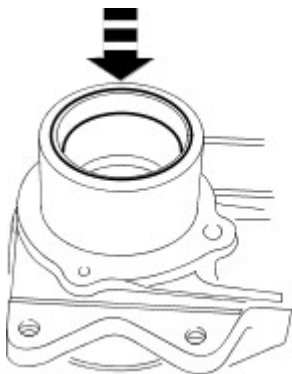

E35148

4. Using a hydraulic press, install outer bearing cup in hub carrier.

1. Install special handle 18G134 to tool 204-118/1

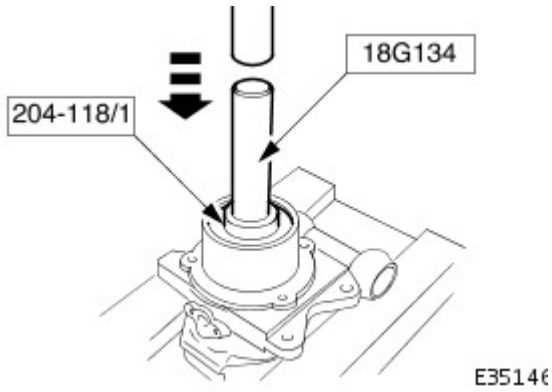

2. Align special tool 204-118/1 to bearing cup.

- Align assembly to ram, and operate press to fully seat bearing cup.

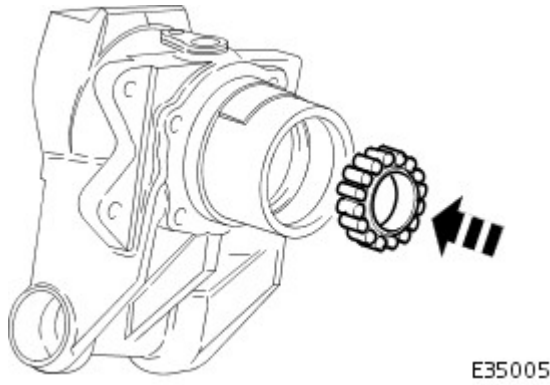

5. Place hub carrier on a work bench.

6. Install outer bearing in hub carrier.

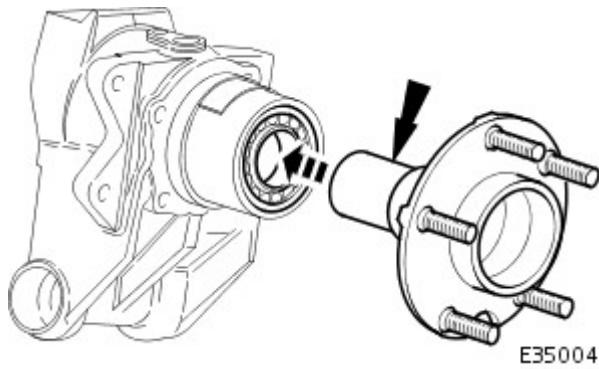

7. Install hub in outer bearing and carrier.

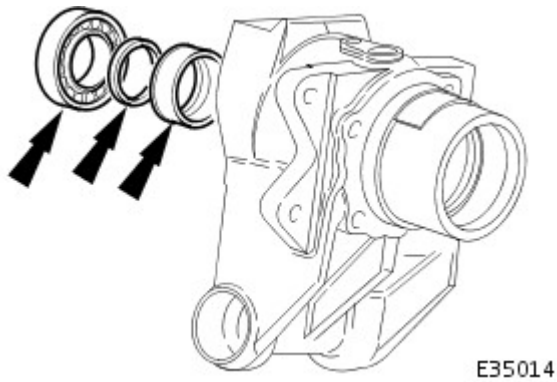

8. Install inner bearing in hub carrier.

1. Install bearing spacer to hub.

2. Install a 3.47 mm (maximum thickness) shim on hub.

3. Install inner bearing in hub carrier.

9.  **CAUTION:** Do not allow press load to be directed on to hub studs.

Using a hydraulic press, install ABS-sensor rotor to hub.

- Place block of wood on press-bed.

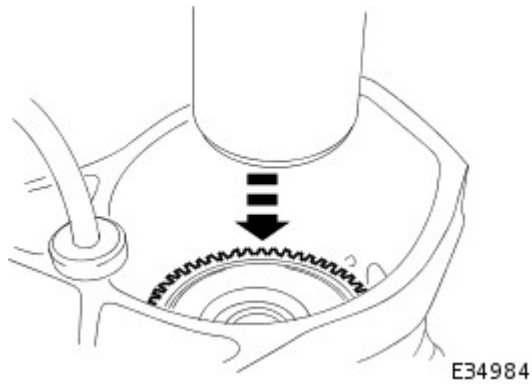

1. Position hub carrier on block of wood.

2. Position ABS-rotor sensor to hub.

- Align assembly to press-ram, and operate press to install ABS-sensor rotor to hub.

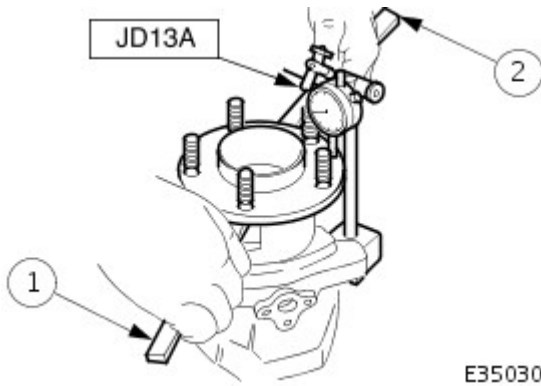

10.  **CAUTION:** Do not use excessive force when levering hub.

Measure hub end-float.

- Secure hub carrier in vice.
- Install special tool JD15 to hub.

1. Install dial gauge JD 13A on hub carrier.

2. Using two levers, measure and record hub end-float.

- Remove special tools from hub carrier.

11. Using hydraulic press, remove hub and outer bearing assembly from carrier.

1. Position large section of special tool JD132 on press bed, with recess in tool upper most.

2. Position hub carrier on tool, ensuring parking brake cable housing locates in tool recess.

3. Position small section of special tool JD132 on hub.

- Align assembly to press-ram, and operate press to remove hub from hub carrier.

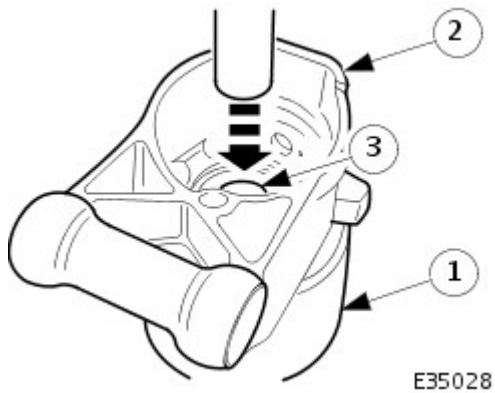

12. Remove ABS rotor and inner bearing from hub carrier.

- Remove ABS rotor.
- Remove inner bearing.

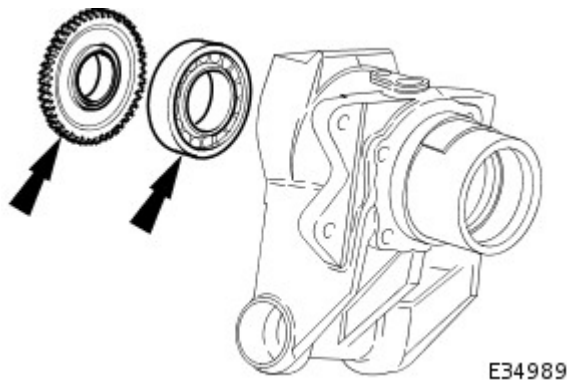

13. Remove outer bearing assembly from hub.

- Remove bearing shim.

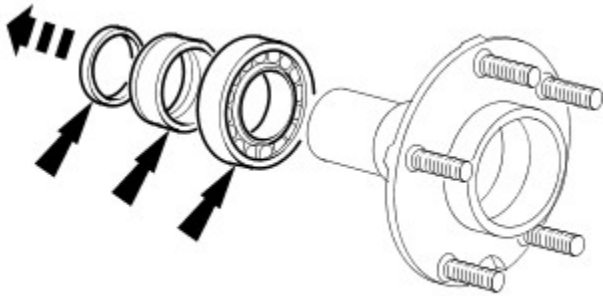

E34990

- Remove bearing spacer.
- Remove outer bearing.

14. Pack new inner and outer bearings with Shell Retinax 'A' grease.

15. Install outer bearing and using special tool 205-234, fully seat seal in hub carrier.

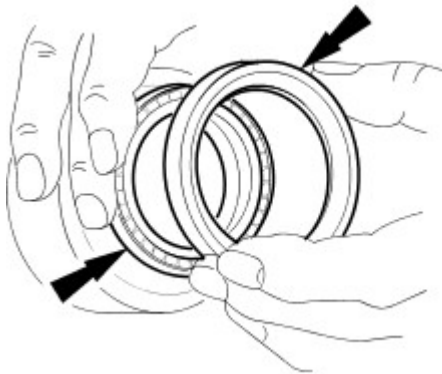

E34980

16. Using a press, install hub in carrier/bearing assembly.

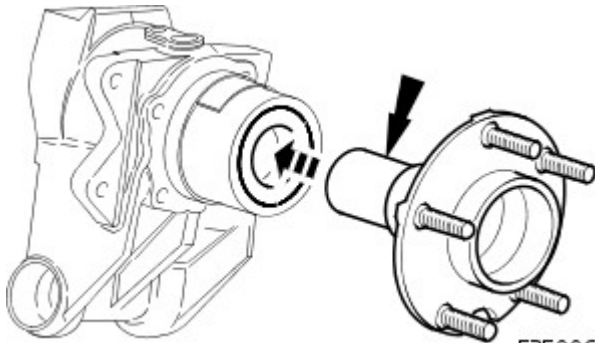

E35006

17. Install inner bearing assembly.

1. Install bearing spacer.
2. Install bearing shim.
3. Install inner bearing.

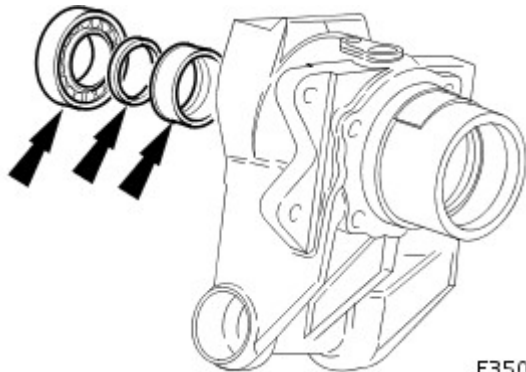

E35014

18. Determine hub end float.

- Measure and record end-float as a datum.
- Calculating from datum, select a shim that will achieve a 0.076 mm end-float.

19. Install new bearing shim.

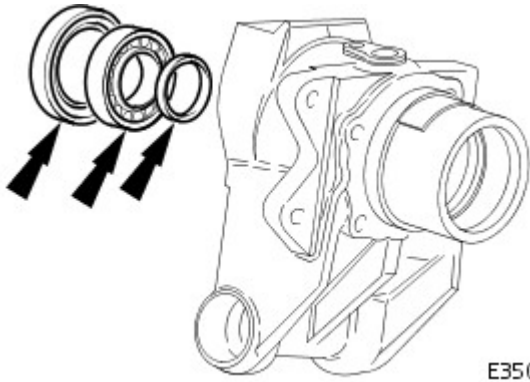

E35015

1. Install selected shim.
2. Install inner bearing.
3. Using special tool 205-234, install inner bearing seal.

20. Place block of wood on hydraulic press-bed and position hub carrier on block.

21.  CAUTION: Do not allow press load to be directed on to hub studs.

Align ABS rotor to hub and operate press to fully seat rotor on hub.

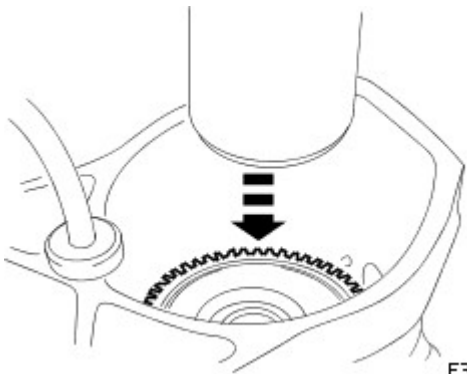

E34984

22. Install pivot pin sleeve in carrier bearings.

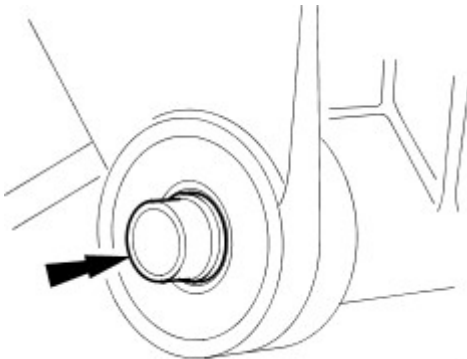

E34985

23. Install shims on pivot pin sleeve in positions noted during removal.

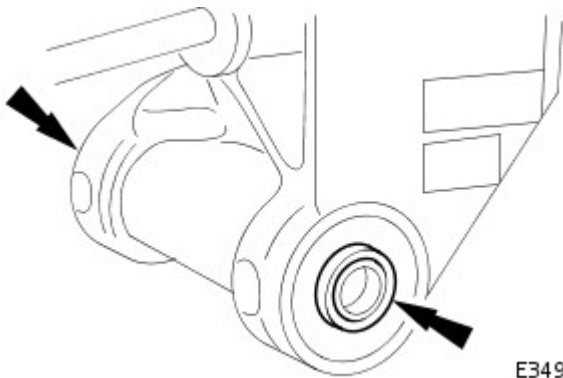

E34978

24. Position hub carrier assembly on wishbone.

1. Ensuring shims remain positioned on sleeve, position hub carrier assembly on wishbone.

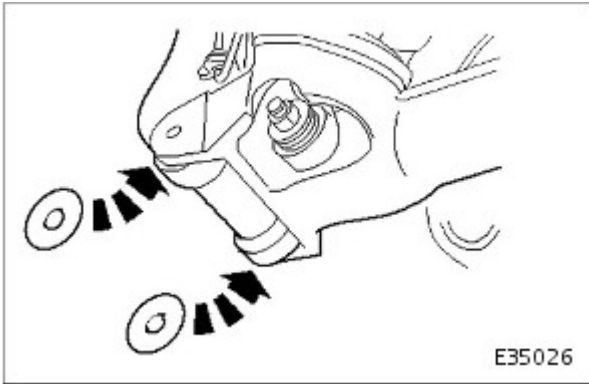

25. Install hub assembly to wishbone and axle assembly.

- Position hub and carrier to wishbone and axle shaft.
- Install pivot pin ensuring that eccentric flange correctly seats in wishbone groove.

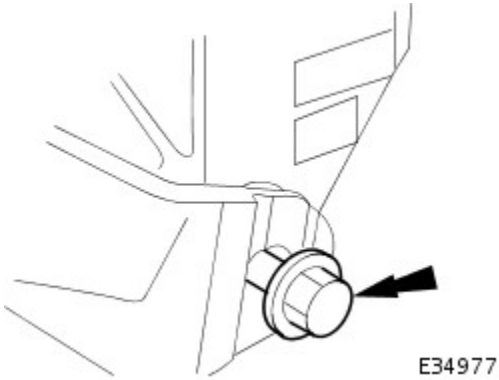

26. Install washer and nut on pivot pin, but DO NOT tighten nut.

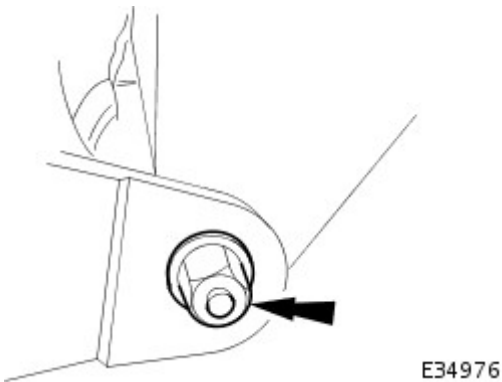

27. Install hub on axle shaft .

- Route parking brake cable through hub carrier aperture and install grommet.
- Apply Loctite 270 to axle shaft splines and thread, and fully seat hub on shaft.

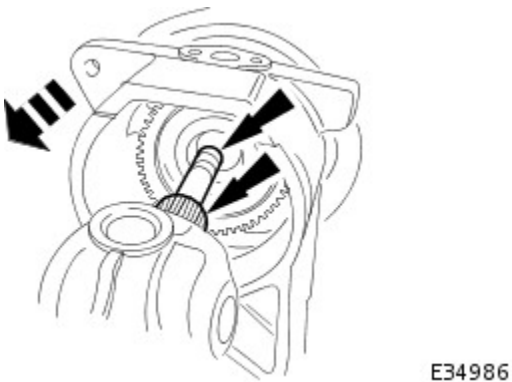

28. Install locating collar and hub nut on axle shaft, but DO NOT tighten hub nut.

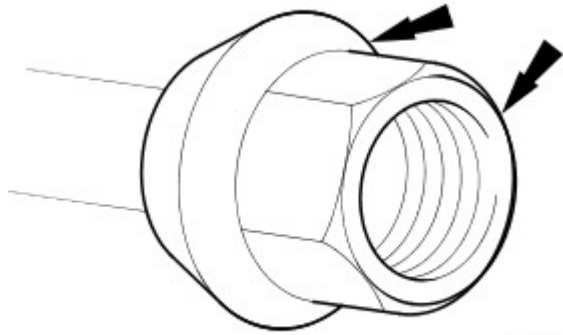

E34972

29. Tighten pivot pin nut.

- Align marker on pivot pin flange with mark made on wishbone.
- Ensuring pin position is not disturbed, tighten nut to 88-118Nm.

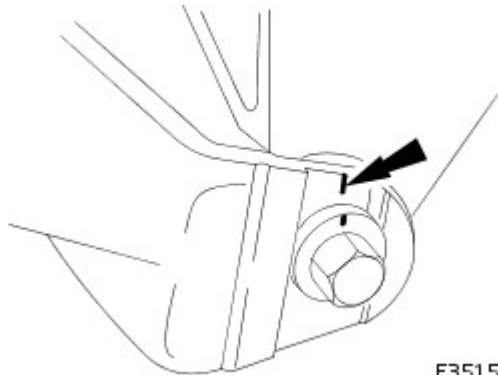

E35153

30. Install wheel speed sensor on hub carrier.

- Position sensor on hub carrier and install and tighten bolt to 7-10Nm.
- Connect wheel speed sensor harness to sensor.

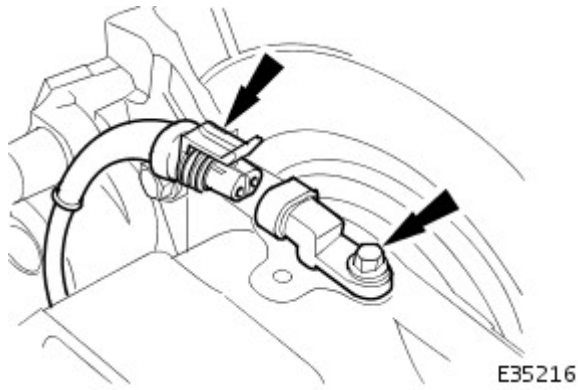

E35216

31. Using new tie strap, secure wheel speed sensor harness to hub carrier.

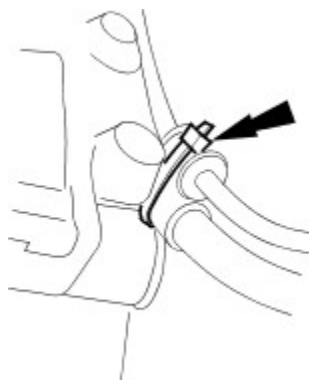

E35235

32. Install handbrake shoes. Refer to operation 70.40.05.

33. Install brake disc. Refer to operation 70.10.13.

34. Position special tool 204-195 on hub studs and install securing nuts.

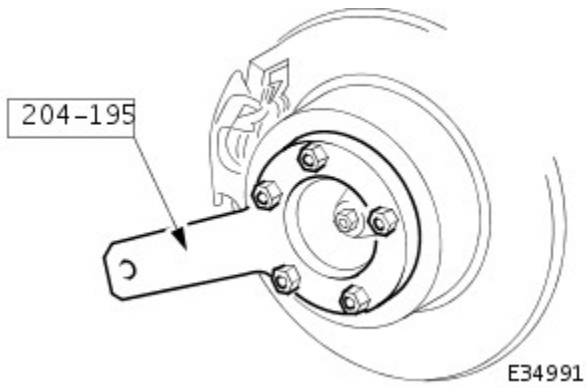

35. Tighten hub nut to 304-336Nm.

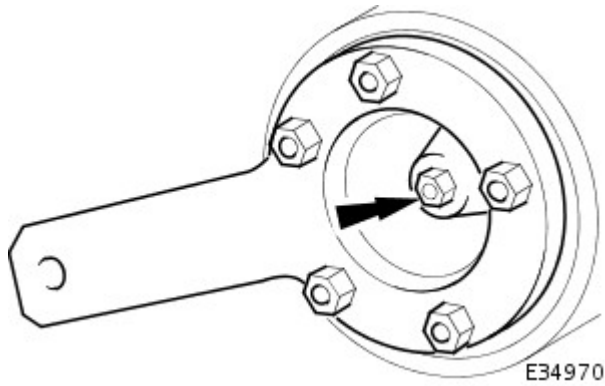

36. Remove securing nuts and withdraw special tool 204-195 from hub.

37. Install rear wheel. Refer to Section 204-04.

38. Remove stands and lower vehicle onto wheels. Refer to section 100-02.

39. Raise vehicle on four-post lift.

40. Route parking brake cable through suspension mounting bracket and secure with clip.

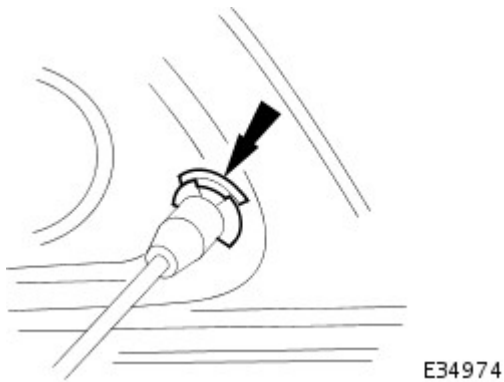

41. Route parking brake LH cable through equalizer.

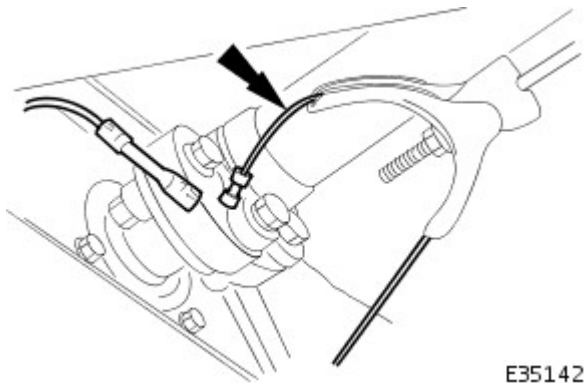

42. Install LH cable in connecting clip.

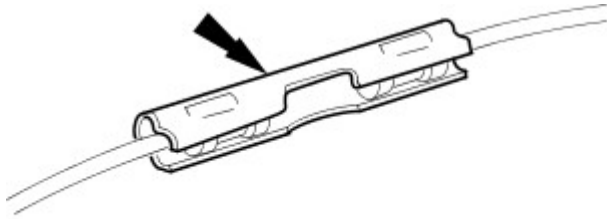

E34975

- 43.** Adjust parking brake cable. Refer to 70.35.10.
- 44.** Lower four-post lift
- 45.** Apply parking brake.
- 46.** Carry out rear wheel alignment check and adjust as necessary. Refer to data in Specification section.