

Brake Shift Interlock Actuator Adjustment

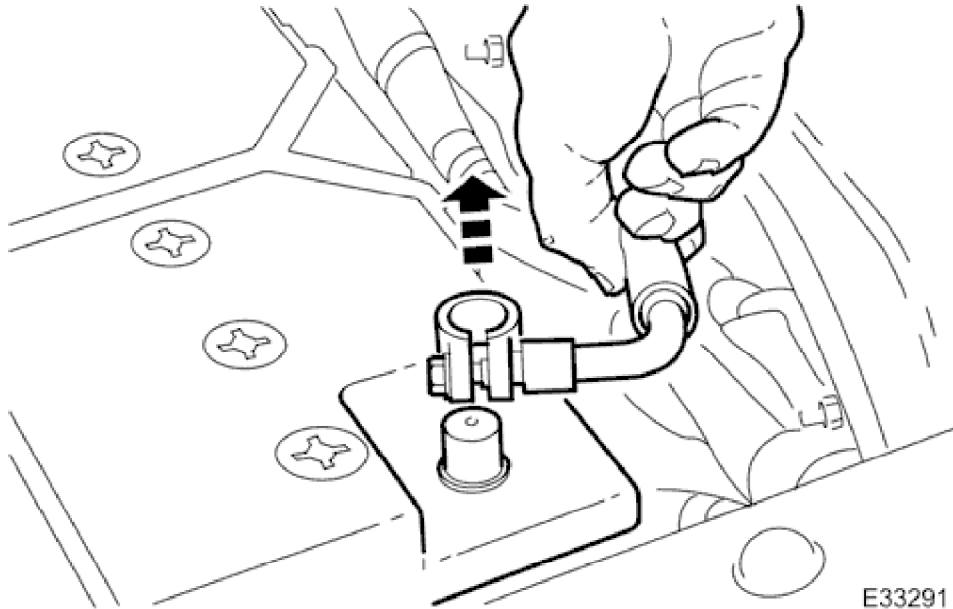

1. Disconnect battery ground cable.
 - Remove the battery cover.
2. Remove the J-gate surround, Section <<501-05>>.
3. Remove the console finisher veneer panel, Section <<501-12>>.

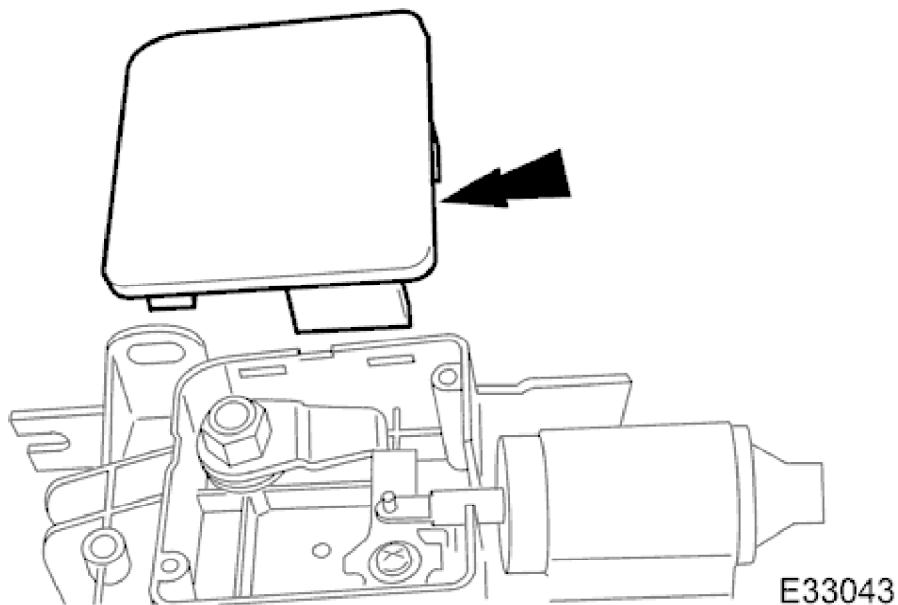

4. Remove the interlock solenoid actuating lever cover.

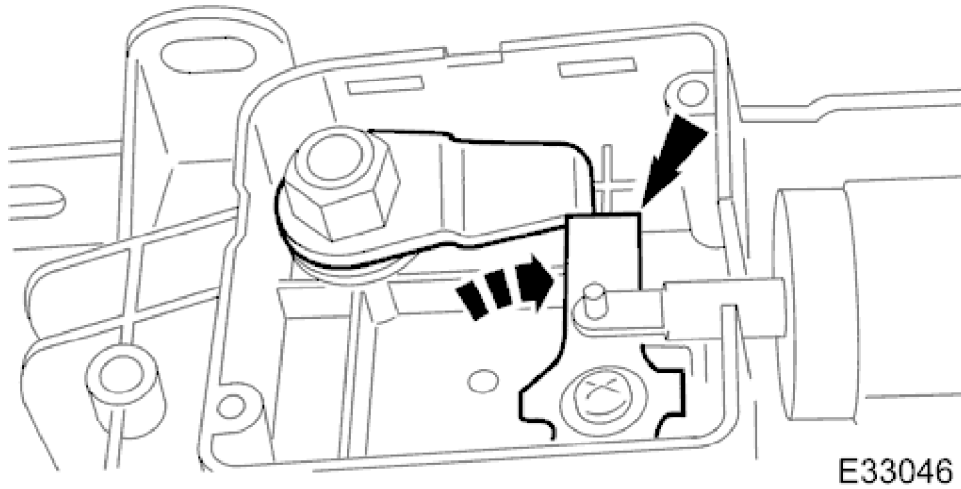

5. Move the shift lever to N.
• Operate the gearshift interlock latch manually to release the selector lever from P .

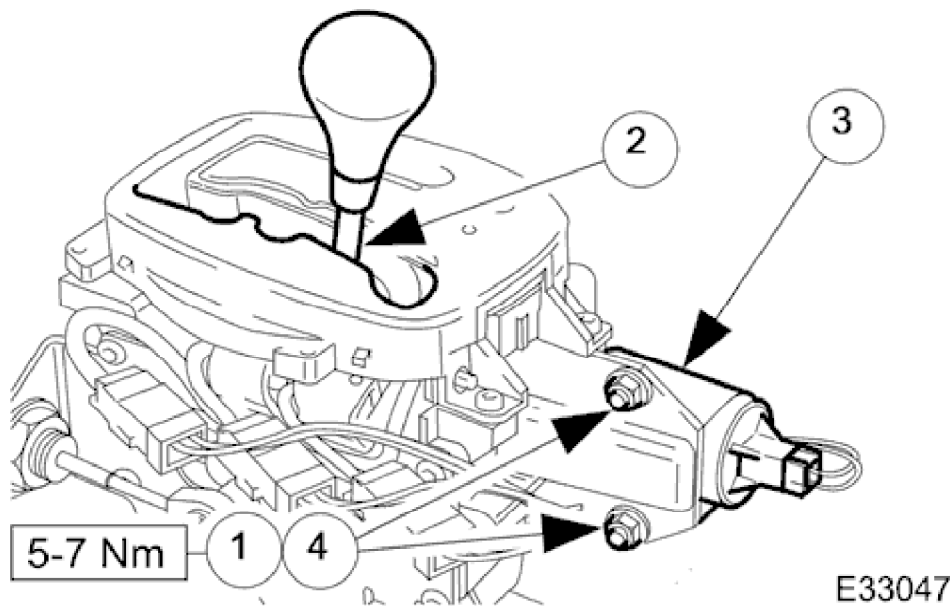

6. **NOTE:**
Assistance from another person is required.
- Adjust the gearshift interlock solenoid.
1. Slacken the solenoid fixings.
 2. Hold the selector lever midway between P and R .
 3. Move the solenoid rearwards, against spring pressure, to take up the free play.
 4. Tighten the solenoid securing nuts.
 5. Ensure that the interlock actuating lever has no free play with the selector lever midway between P and R .
7. Further installation is the reverse of the removal procedure.
8. Connect the battery and fit the battery cover.

1999 XJ RANGE - Automatic Transmission/Transaxle External Controls - Vehicles Without: S

- Reset the radio and the clock.