

## Brake Disc 70.10.11

Removal  **WARNING:**  
BRAKE DISCS MUST ALWAYS BE REPLACED IN PAIRS.

 **WARNING:**  
BRAKE DUST, IF INHALED CAN DAMAGE YOUR HEALTH. ALWAYS REMOVE BRAKE DUST USING A VACUUM BRUSH. DO NOT USE A COMPRESSED-AIR LINE TO DISPERSE BRAKE DUST INTO THE ATMOSPHERE.

 **CAUTION:**  
Replacement of nuts and bolts: Various thread-locking devices are used on nuts and bolts throughout the vehicle. These devices restrict the number of times a nut or bolt can be used. See section <<100-00>> for information.

1. Open engine compartment and fit paint work protection covers to fenders.
2. Raise rear of vehicle and support on stands. Refer to section <<100-02>>.
3. Remove rear wheels. Refer to section <<204-04>>.

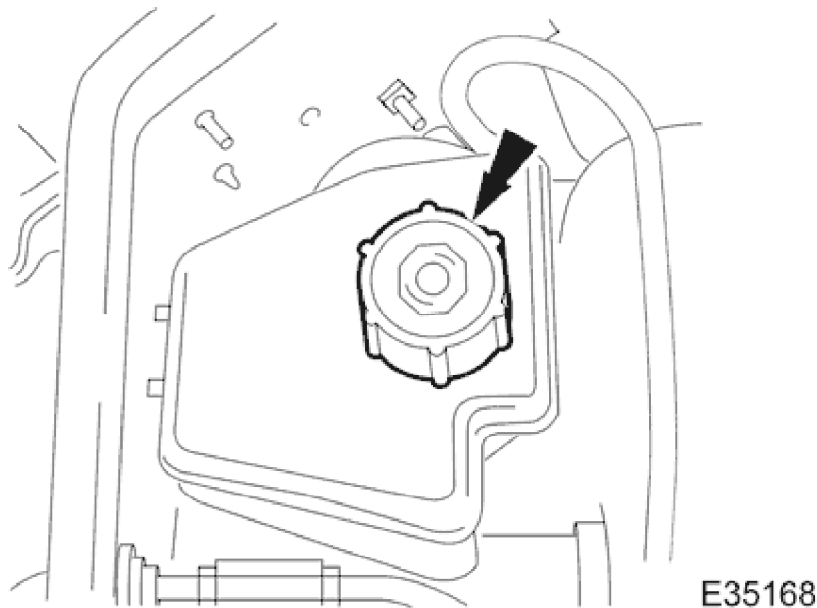



4.  **CAUTION:**  
Remove brake fluid spillage immediately from paint work, with clean water.

Loosen brake fluid reservoir-cap.

- Position a cloth around the reservoir to collect any fluid spillage.

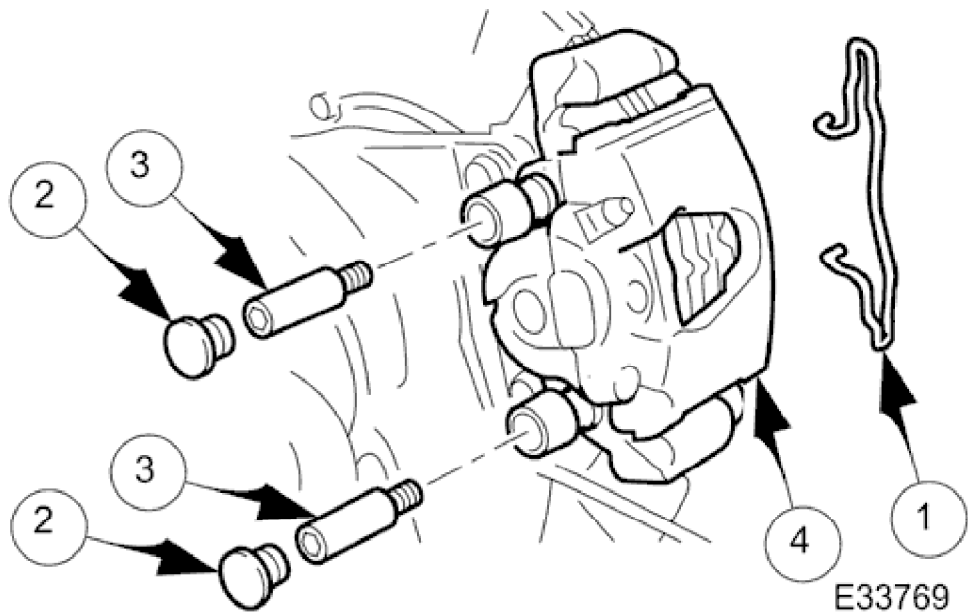
# 1999 XJ RANGE - Rear Disc Brake - 206-04



5.  **CAUTION:**  
Tie caliper housing aside. Do not allow the caliper housing to hang on the hydraulic hose, as this will damage the hose.

Remove caliper housing from caliper carrier.

- 1. Remove anti-rattle spring.
- 2. Remove dust covers.
- 3. Remove guide pins.
- 4. Remove housing from carrier.
- Tie caliper housing aside.

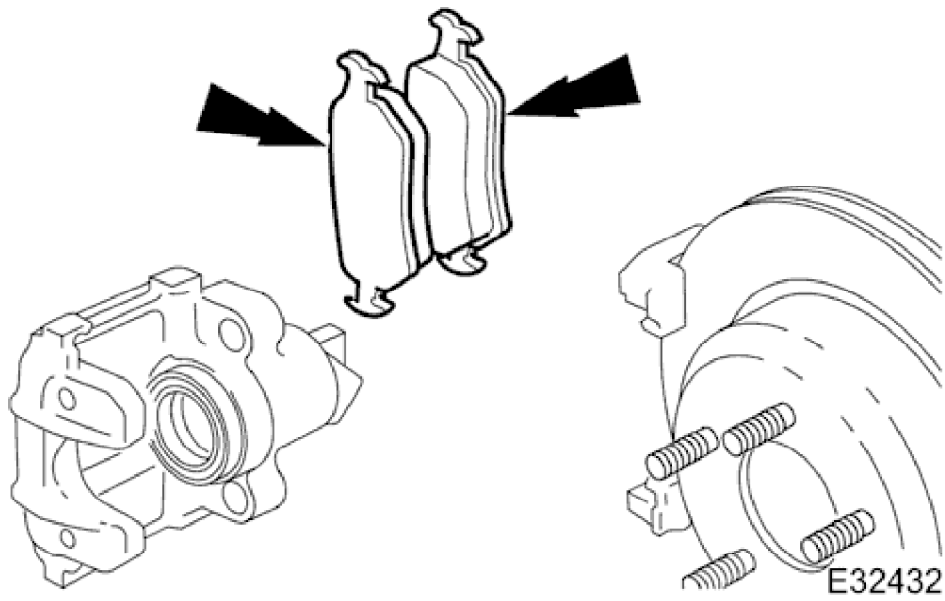

6.  **CAUTION:**

## 1999 XJ RANGE - Rear Disc Brake - 206-04

**Always install new brake pads, irrespective of the condition of the original pads, when renewing a brake disc.**

**NOTE:**

The inner brake pad is fitted with a clip which secures the pad into the caliper piston.

Remove brake pads from caliper housing.

- Discard brake pads.

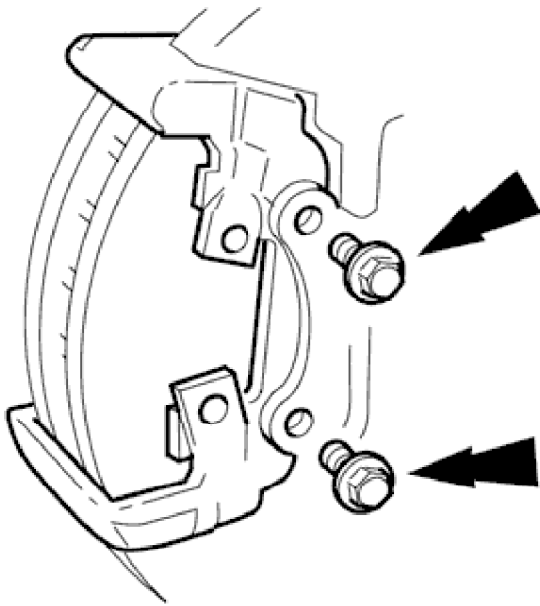

E32433

7. Remove caliper carrier from hub carrier.

- Remove bolts.
- Remove carrier.

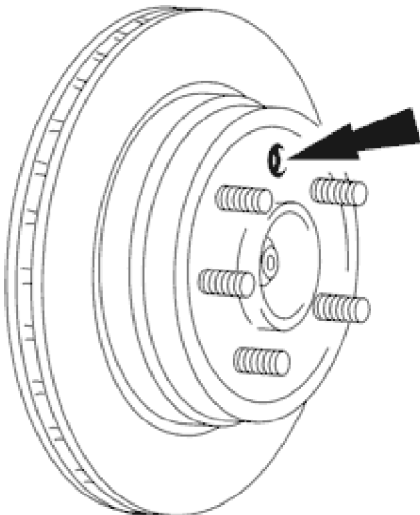

E33779

8. Align brake disc access hole with parking brake adjuster.

- Remove plug from access hole.
- Rotate brake disc until access hole is aligned with adjuster.

## 1999 XJ RANGE - Rear Disc Brake - 206-04

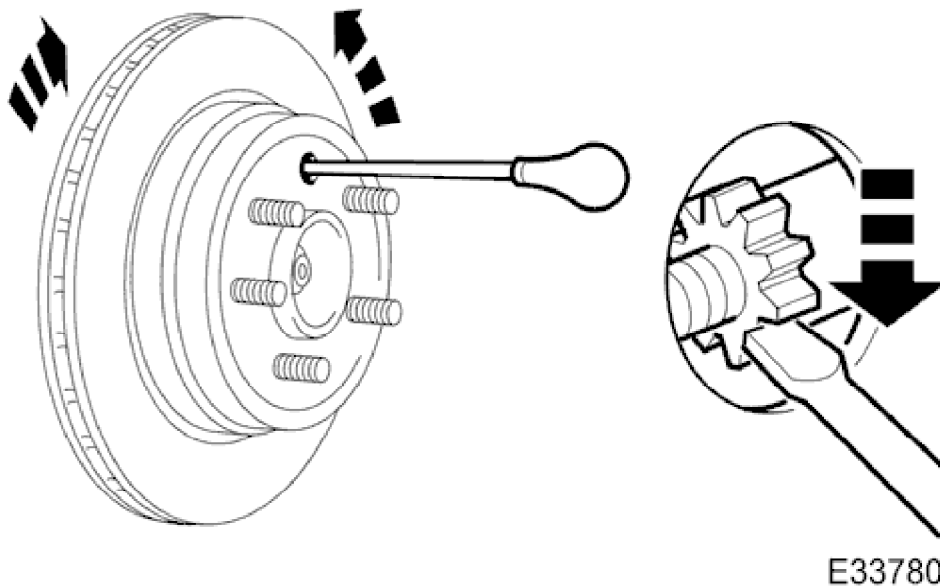

9. Slacken parking brake adjuster.
- Rotate adjuster clockwise.

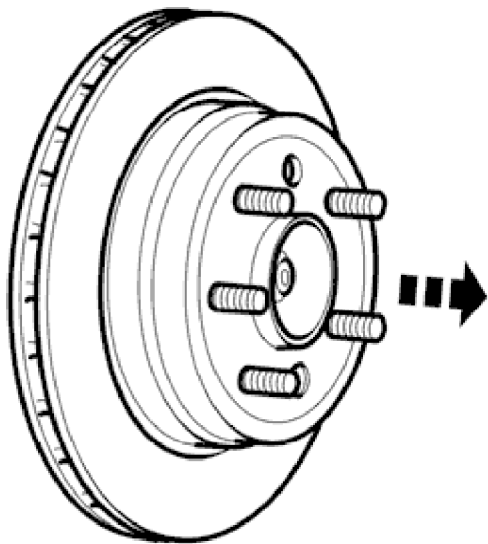

10. Remove brake disc from wheel studs.
11. Remove brake dust from calipers, and from area of parking brake shoes, see WARNING above.
12. Repeat above procedure to remove opposite side brake disc.
13. Thoroughly clean the area of both hubs where they mate against the brake discs.

### Installation

## 1999 XJ RANGE - Rear Disc Brake - 206-04

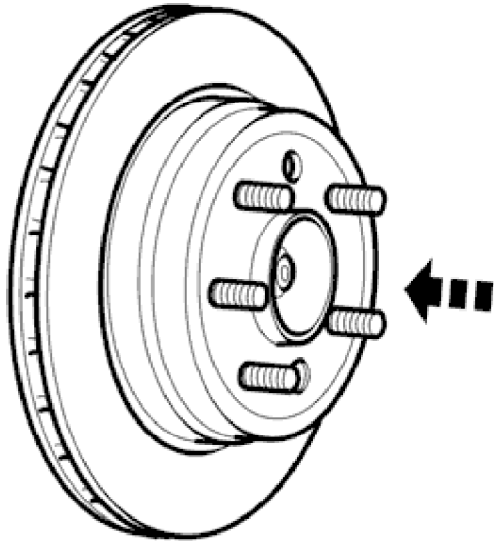

E32435

1. Install brake disc to wheel studs.
  - Make sure hub and brake disc access holes are aligned.
2. Set the parking brake, refer to operation <<70.35.37>>.
3. Check brake disc run-out. Refer to General Procedures section <<206-04>>.

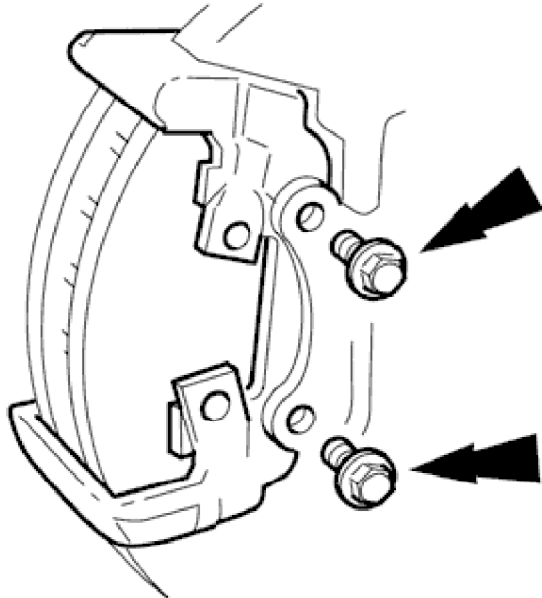

E32433

4. Install caliper carrier to hub carrier.
  - Position carrier.
  - Install and tighten bolts to 54-66 Nm.

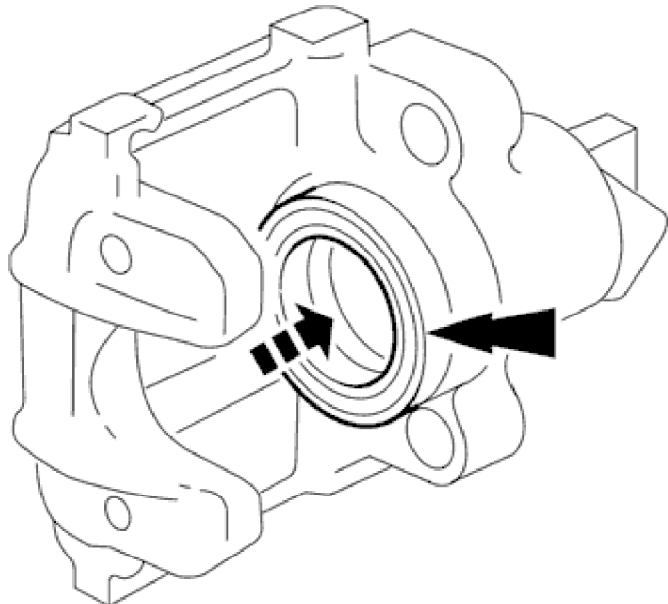

E32416

5.  **CAUTION:**  
Retracting the caliper piston may cause the fluid reservoir to over-flow. Remove brake fluid spillage immediately from paint work, with clean water.

Slowly retract piston into caliper housing.

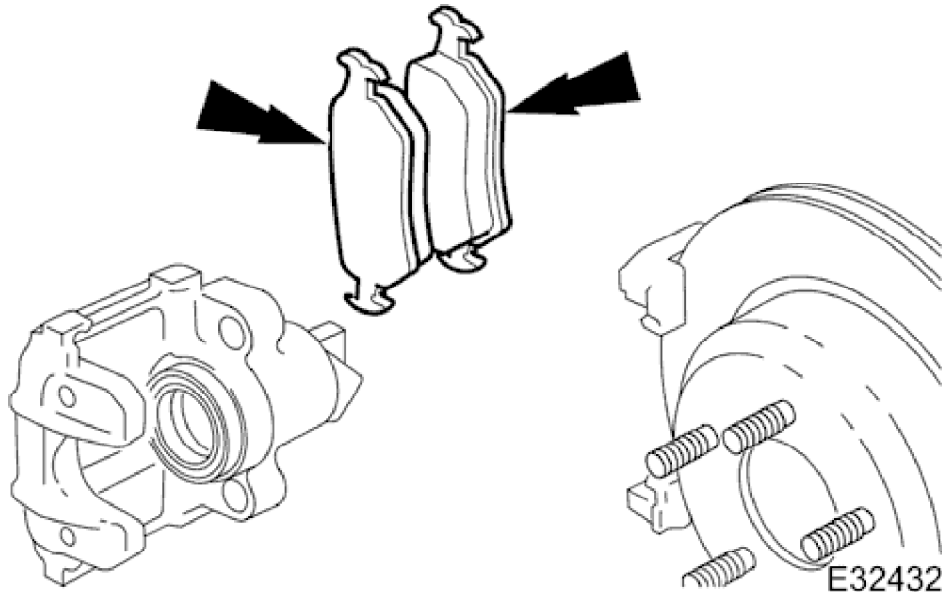

E32432

6.  **CAUTION:**  
Always install new brake pads, irrespective of the condition of the original pads, when renewing a brake disc.

**NOTE:**  
Clean caliper piston to pad mating surface.

## 1999 XJ RANGE - Rear Disc Brake - 206-04

Install brake pads to caliper housing.

- Remove paper backing from pads to reveal adhesive shim. Install brake pads, insert clip located on back of inner pad into caliper piston.

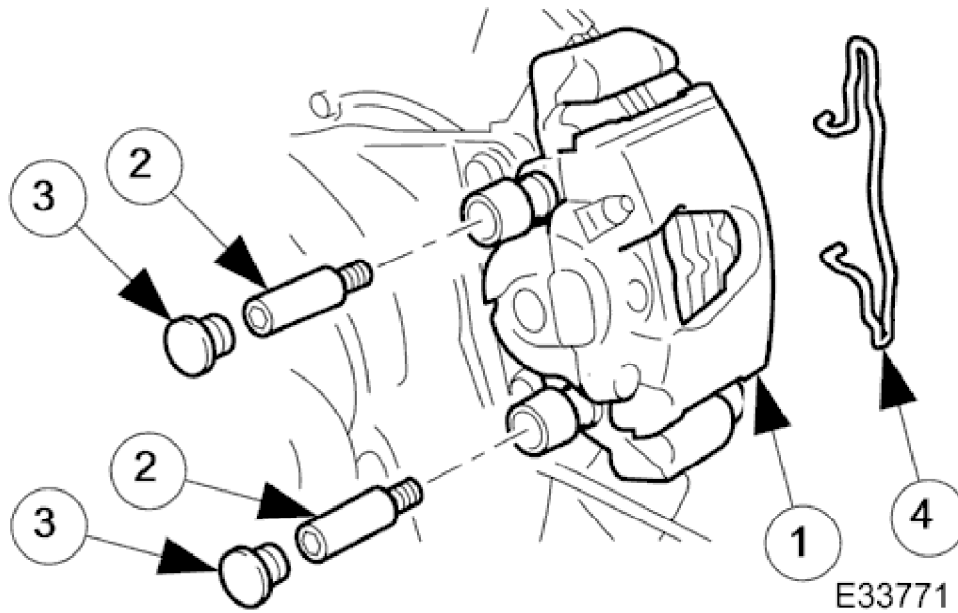

7. Install caliper housing to caliper carrier.

1. Align housing to carrier.
2. Install and tighten guide pins to 25-30 Nm.
3. Install dust covers.
4. Install anti-rattle spring.

8. Repeat above procedure to install opposite side brake disc.

9. Fit wheels. Refer to section <<204-04>>.

10. Remove stands and lower vehicle. Refer to section <<100-02>>.

## 1999 XJ RANGE - Rear Disc Brake - 206-04

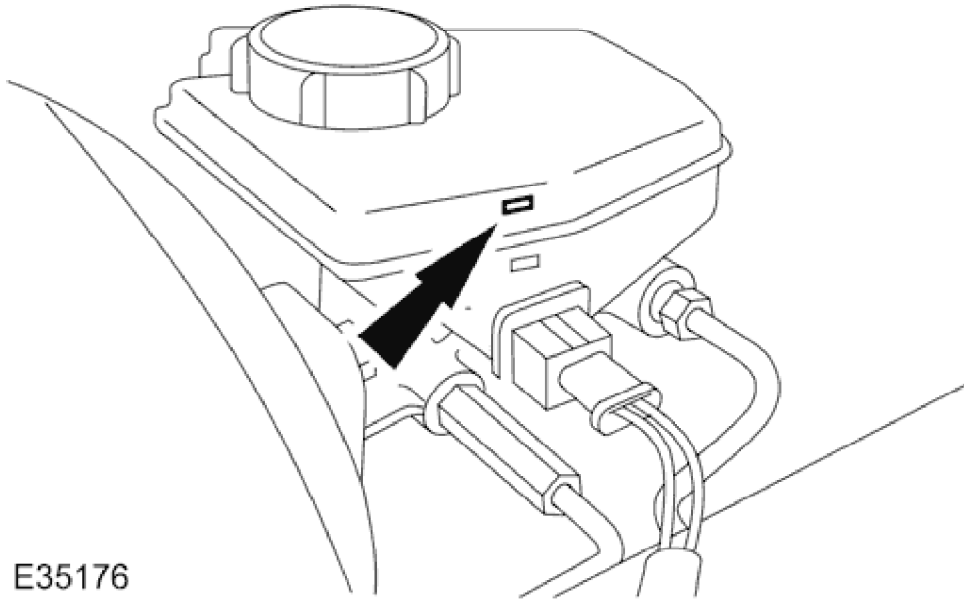

E35176

11.  **CAUTION:**  
**Remove brake fluid spillage immediately from paint work, with clean water.**

Check brake fluid level.

- Check brake fluid level is at the maximum mark.
  - Remove cloth.
  - Fit cap.
12. Remove paint work protection covers, and close engine compartment.
13. Start the engine and repeatedly press the brake pedal until brake pressure is evident.