



Parking Brake Shoes 70.40.05

Removal  **WARNING:**
BRAKE DUST, IF INHALED CAN DAMAGE YOUR HEALTH. ALWAYS REMOVE BRAKE DUST USING A VACUUM BRUSH. DO NOT USE A COMPRESSED-AIR LINE TO DISPERSE BRAKE DUST INTO THE ATMOSPHERE.

 **CAUTION:**
Replacement of nuts and bolts: Various thread-locking devices are used on nuts and bolts throughout the vehicle. These devices restrict the number of times a nut or bolt can be used. See section <<100-00>> for information.

1. Raise rear of vehicle and support on stands. Refer to section <<100-02>>.
2. Remove both rear wheels.
3. Remove both rear brake discs. Refer to operation 70.10.13.

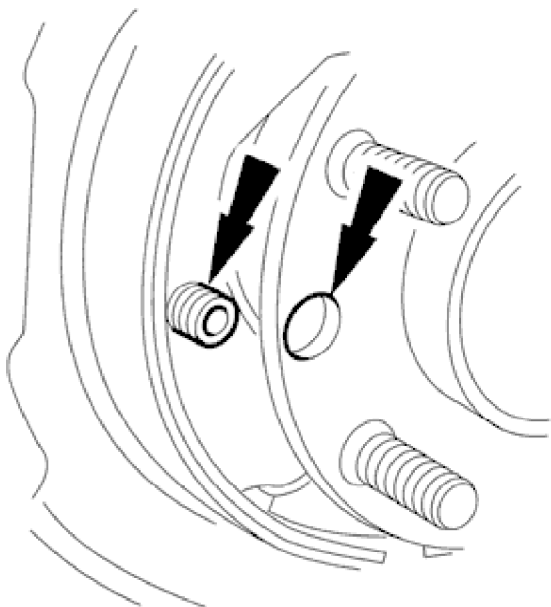

E35192

4. Remove front shoe retaining pin.
 - Align hub access hole with retaining pin.
 - Turn pin until it releases from backing plate.

1999 XJ RANGE - Parking Brake and Actuation - 206-05

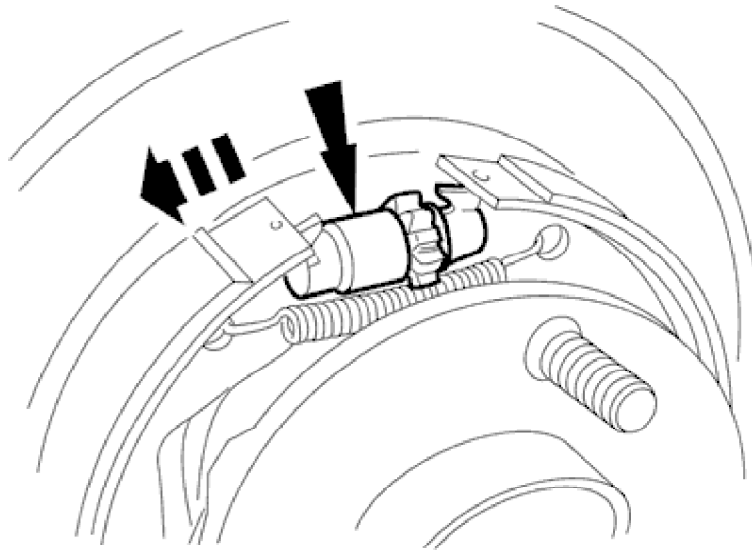

E35193

- 5. Remove adjuster assembly.
 - Move front shoe forwards.
 - Remove adjuster assembly.

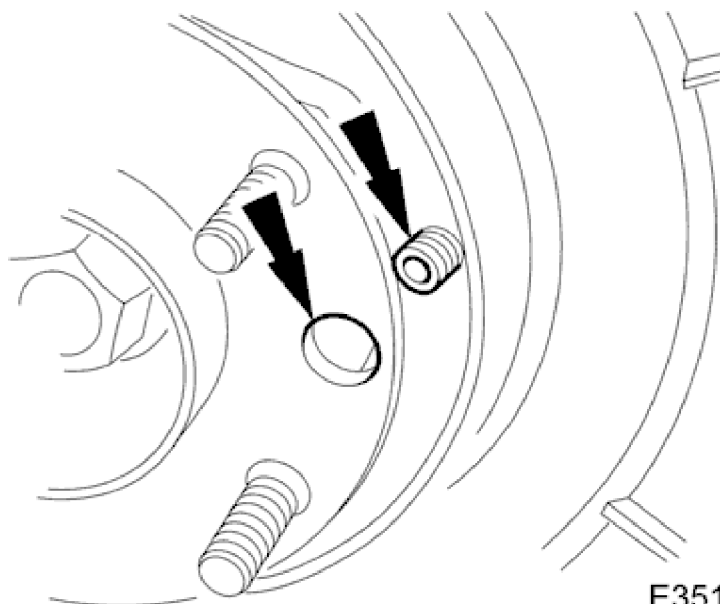

E35194

- 6. Remove rear shoe retaining pin.
 - Align hub access hole with retaining pin.
 - Turn pin until it releases from backing plate.

7. Remove brake shoes from parking brake lever-mechanism and remove shoes from vehicle.

1999 XJ RANGE - Parking Brake and Actuation - 206-05

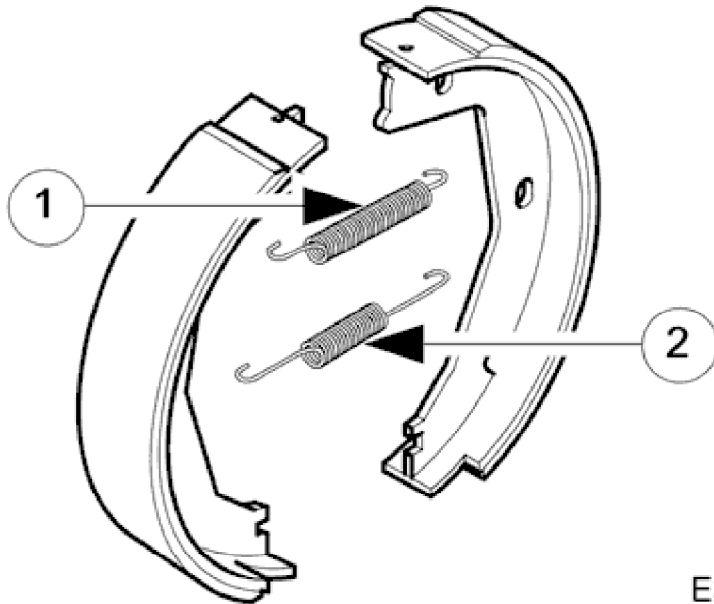

E35196

8. Remove return springs from shoes.
 1. Remove upper return spring.
 2. Remove lower return spring.

9. Remove brake dust and clean components, see WARNING above.

10. Repeat procedure to remove parking brake shoes on opposite side of vehicle.

Installation

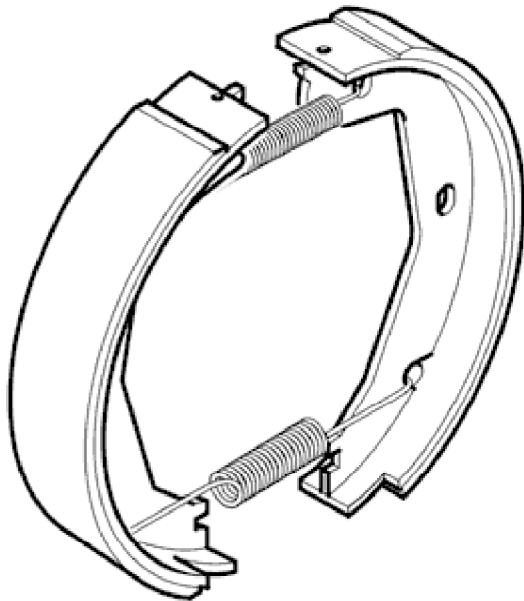

E35195

1. Install brake shoes to vehicle.
 - Install brake shoes to parking brake lever-mechanism in the arrangement shown.

1999 XJ RANGE - Parking Brake and Actuation - 206-05

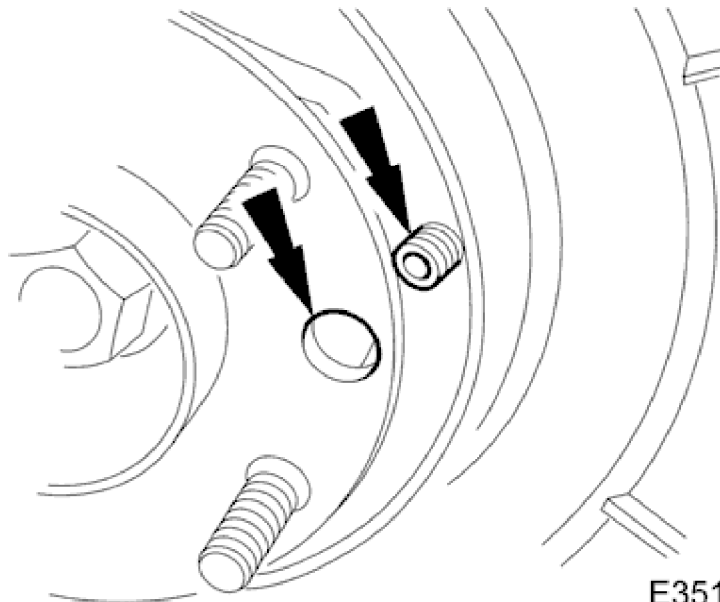

2. NOTE:

Make sure retaining pin is seated correctly in backing plate.

Install rear shoe retaining pin.

- Align hub access hole.
- Install retaining pin.

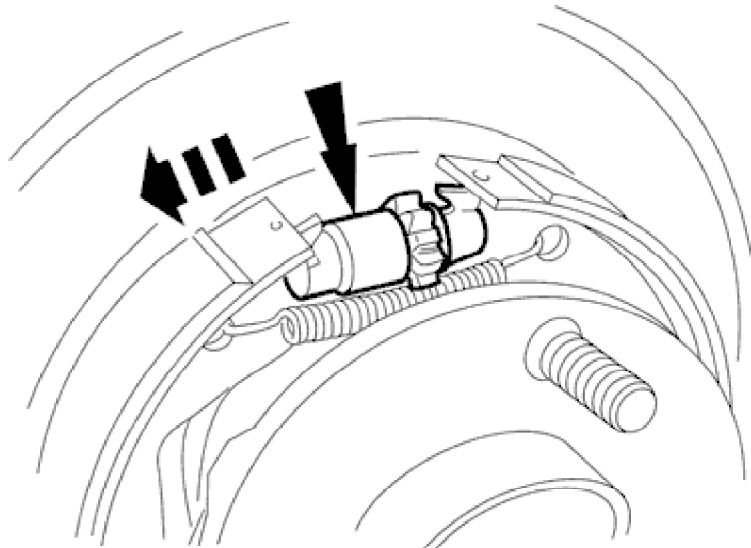

E35193

3. Install adjuster assembly.

- Lubricate adjuster mechanism with appropriate grease.
- Move front shoe forwards.
- Install adjuster assembly.

1999 XJ RANGE - Parking Brake and Actuation - 206-05

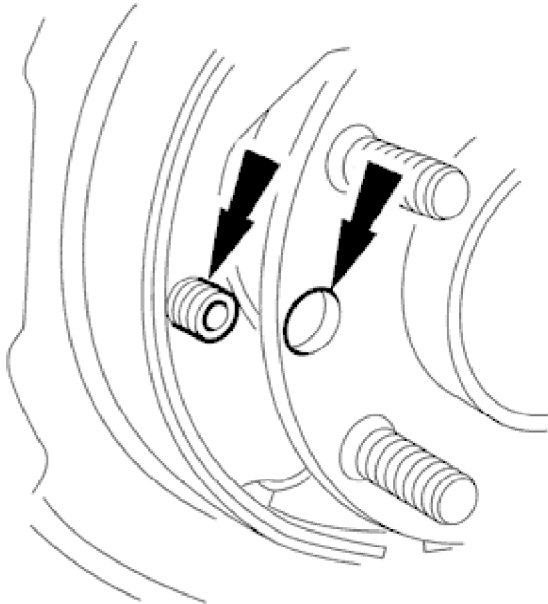

E35192

4. NOTE:

Make sure retaining pin is seated correctly in backing plate.

Install front shoe retaining pin.

- Align hub access hole.
- Install retaining pin.

5. Make sure brake shoes are seated correctly in adjuster and lever mechanism.

6. Repeat procedure to install parking brake shoes on opposite side of vehicle.

7. Install both rear brake discs. Refer to operation 70.10.13.

8. Set parking brake. Refer to operation <<70.35.37>>.

9. Fit rear wheels. See section <<204-04>>.

10. Remove stands and lower vehicle.