

# 1998 XJ RANGE - Rear Suspension - 204-02

## Stabilizer Bar Mounting Frame Bushing 64.25.13

### Special Service tools

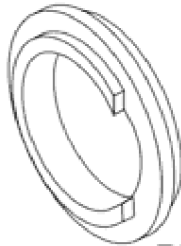

E36446

Adaptor Ring  
204-116-01 (JD 143-1)

---

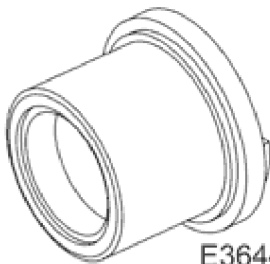

E36447

Anvil Adaptor  
204-116-02 (JD 143-2)

---

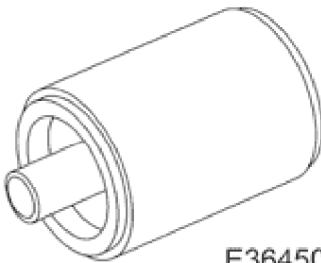

E36450

Remover/Replacer Adaptor  
204-116-08 (JD 143-8)

---

## 1998 XJ RANGE - Rear Suspension - 204-02

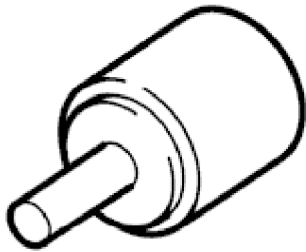

E36425

Differential Strut - Bush Replacer  
204-201 (JD 241)

**Removal**  **CAUTION:**  
**Replacement of nuts and bolts: Various thread-locking devices are used on nuts and bolts throughout the vehicle. These devices restrict the number of times a nut or bolt can be used. See section <<100-00>> for information.**

1. Remove monostrut from vehicle. Refer to operation <<64.25.12>>.

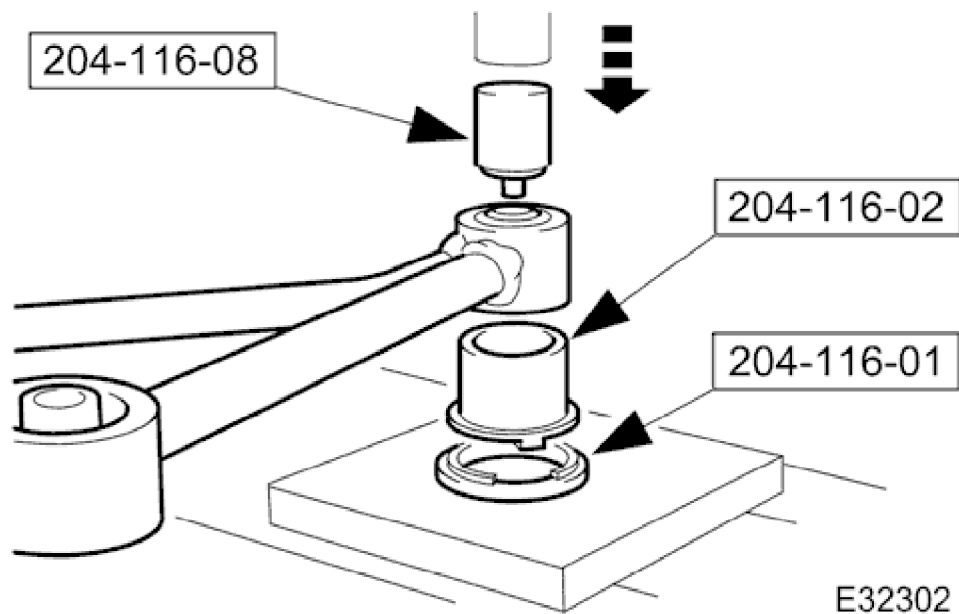

2. Using a hydraulic press remove bush from monostrut.
  - Using special tools, support monostrut on the press bed.
  - Position special tool on top of bush and align tool with press ram.
  - Press bush from monostrut.

3. Clean relevant parts.

# 1998 XJ RANGE - Rear Suspension - 204-02

## Installation

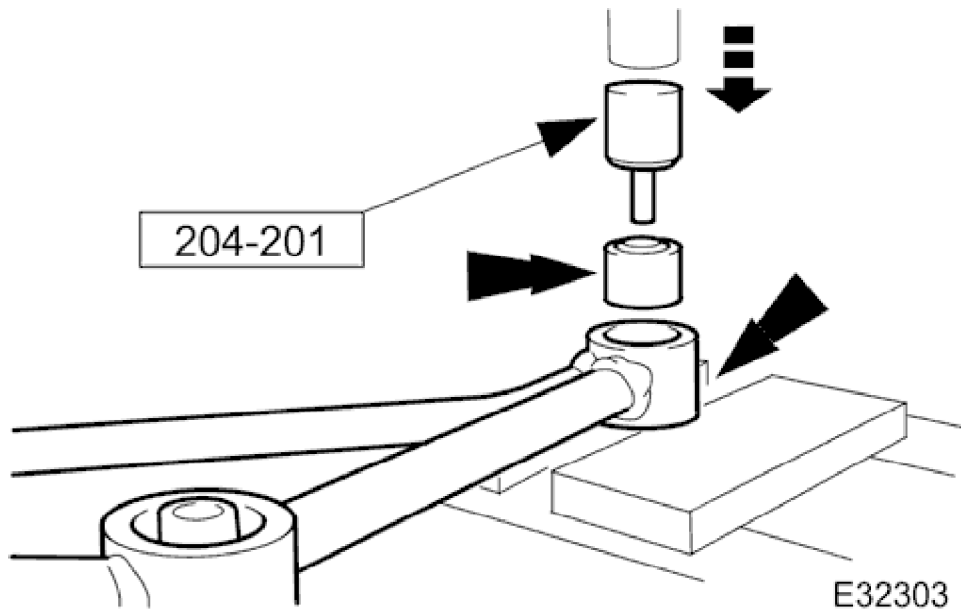

1. Using a hydraulic press, fit bush into monostrut.
  - Support the bush-bore of the monostrut between plates on the press-bed.
  - Position bush to bore.
  - Position special tool on top of bush and align tool with press ram.
  - Press bush into monostrut.
2. Install monostrut on vehicle. Refer to operation <<64.25.12>> .