

Stabilizer Bar Mounting Frame 64.25.12

Removal 

CAUTION:

Replacement of nuts and bolts: Various thread-locking devices are used on nuts and bolts throughout the vehicle. These devices restrict the number of times a nut or bolt can be used. See section <<100-00>> for information.

1. Raise rear of vehicle and support on stands. Refer to Section <<100-02>>.

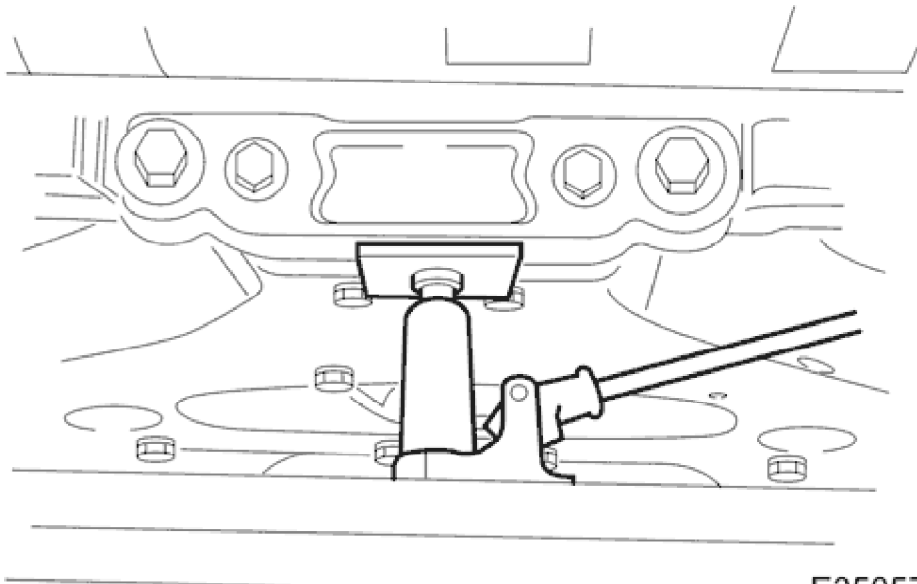

2. Support rear suspension.
 - Position a piece of wood under rear edge of suspension unit.
 - Position and raise a jack under wood to support suspension unit.

1998 XJ RANGE - Rear Suspension - 204-02

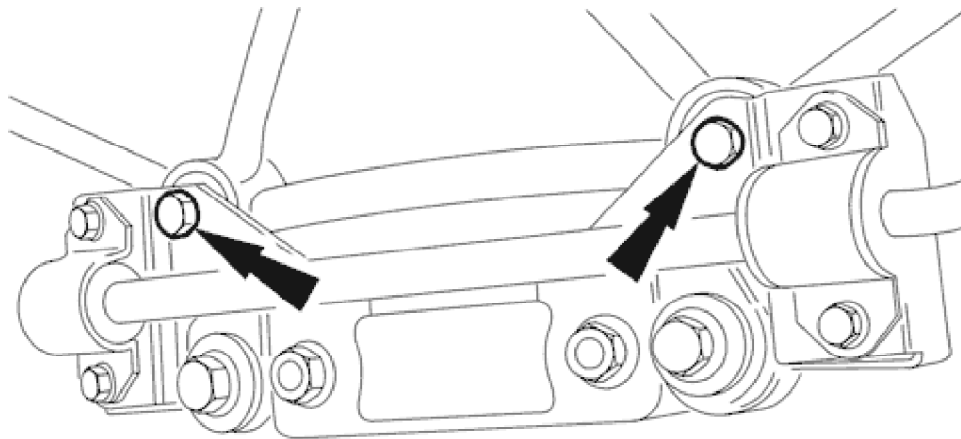

E35058

3. Remove monostrut lower nuts and bolts.

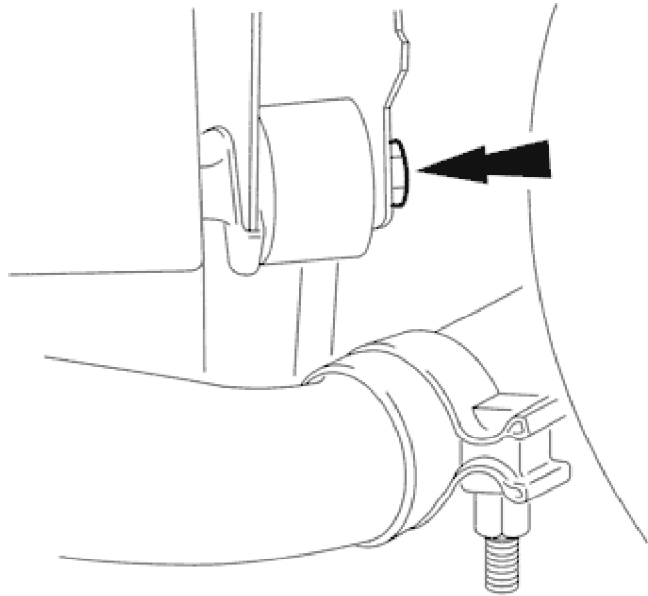

E35059

4. Remove monostrut upper mounting to body bracket securing bolts.

1998 XJ RANGE - Rear Suspension - 204-02

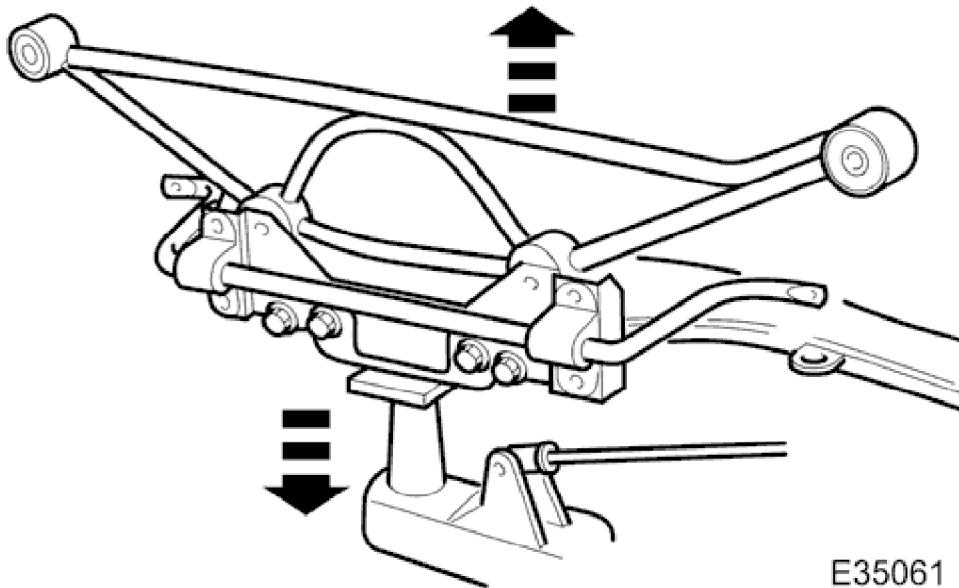

5. Remove monostrut.

- Lower rear edge of suspension unit just sufficient for access.
- Exercising care to avoid damaging fuel filler neck drain pipe, lift and withdraw monostrut from rear suspension.

Installation

1. Position monostrut on rear suspension.

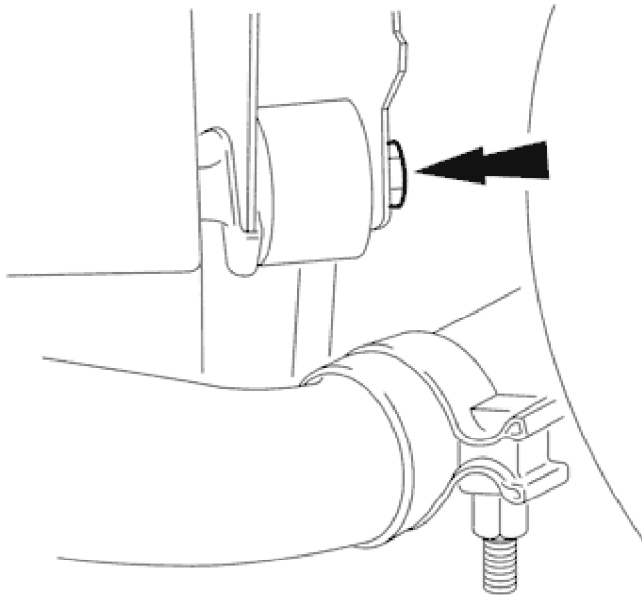

2. Align monostrut upper mountings and install but do not tighten bolts

1998 XJ RANGE - Rear Suspension - 204-02

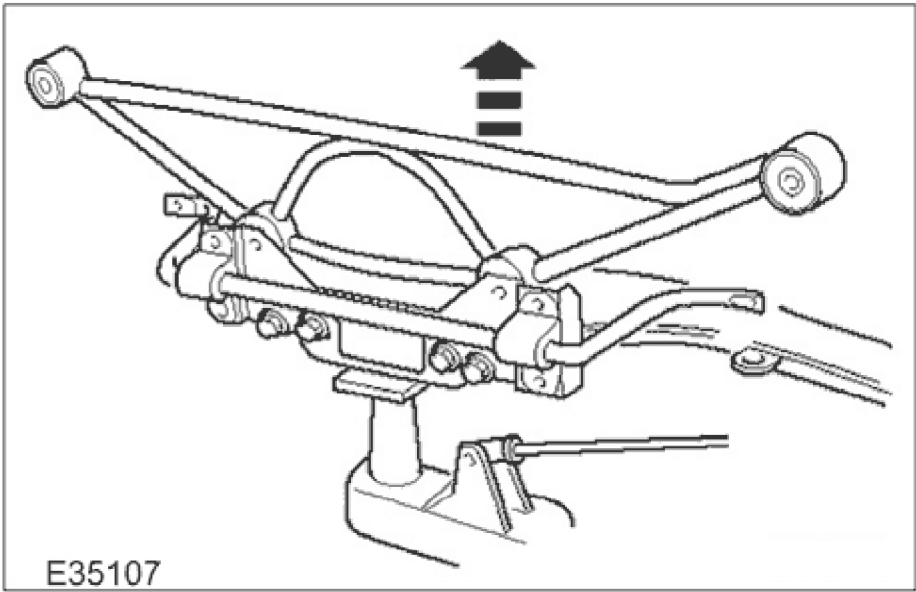

3. Raise rear of suspension to align with monostrut lower mounting holes.

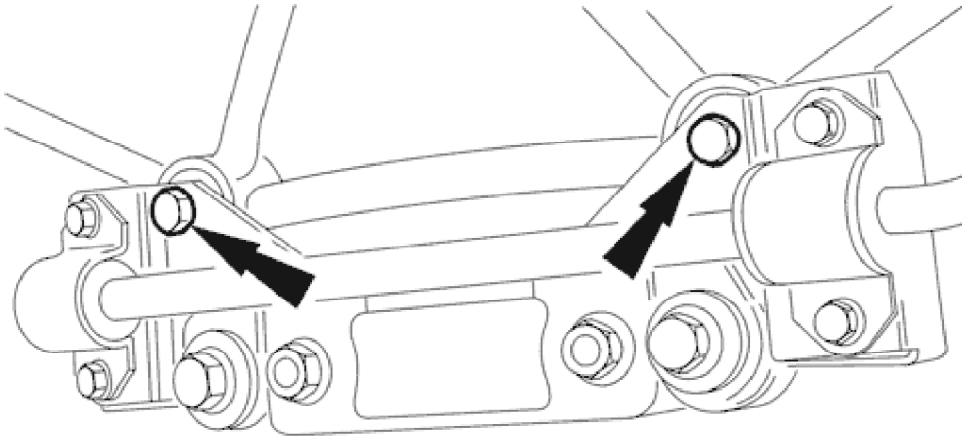

4. Install monostrut lower bolts and nuts and tighten to 77-103 Nm.

1998 XJ RANGE - Rear Suspension - 204-02

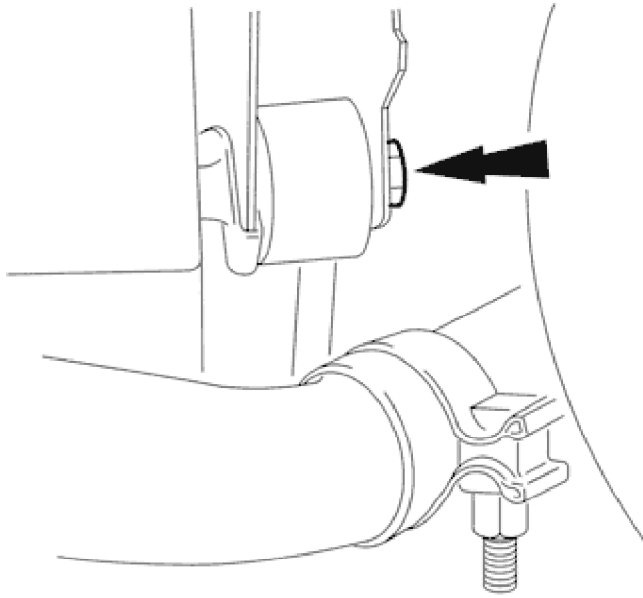

E35059

5. Tighten monostrut upper bolts to 88-118 Nm.
6. Raise vehicle, remove stands and lower vehicle. Refer to Section <<100-02>>.