

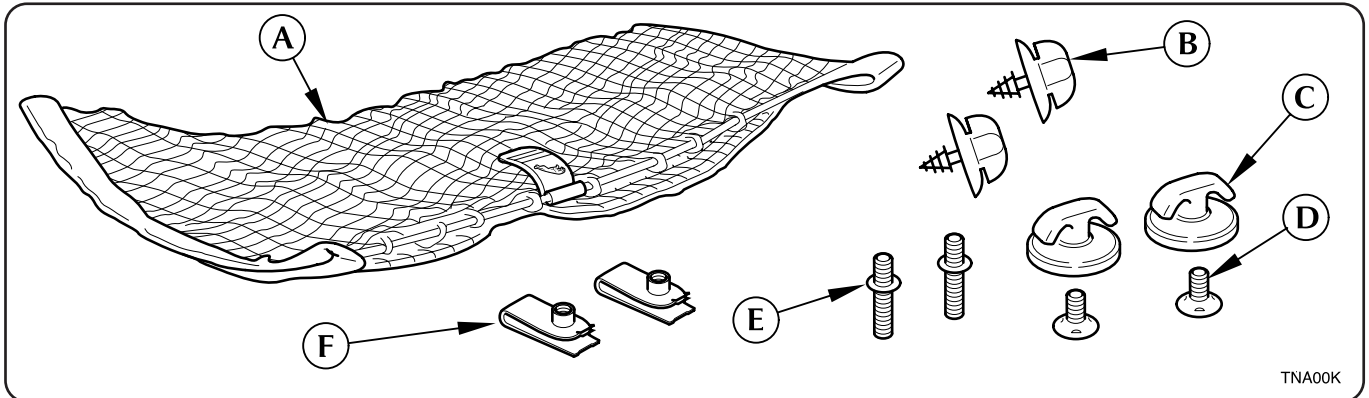

**FITTING INSTRUCTIONS, INSTRUCTIONS DE MONTAGE,
EINBAUANLEITUNG, ISTRUZIONI DI MONTAGGIO,
INSTRUCCIONES DE MONTAJE, 取扱説明書**

All Models

**Car Tidy Net, Filet de rangement, Gepäcknetz,
Retina portaoggetti, Red de almacenamiento,
車両用整頓ネット**



TNA00K

Content of kit

- A. Net
- B. Hooks, carpet fixing
- C. Hooks, board fixing
- D. Studs, board fixing
- E. Studs
- F. Retaining clips (S-TYPE & X-TYPE only)

Contenu du kit

- A. Filet
- B. Crochets, fixation tapis
- C. Crochets, fixation planche
- D. Goujons, fixation planche
- E. Goujons
- F. Clips de fixation (S-TYPE et X-TYPE uniquement)

Lieferumfang

- A. Netz
- B. Befestigungshaken (Montage auf Teppich)
- C. Befestigungshaken (Montage auf festem Untergrund)
- D. Stiftschrauben (Montage auf festem Untergrund)
- E. Stiftschrauben
- F. Halteclips (nur S-TYPE und X-TYPE)

Contenuto del kit

- A. Retina
- B. Ganci per il fissaggio al tappetino
- C. Ganci per il fissaggio ai pannelli
- D. Prigionieri per il fissaggio ai pannelli
- E. Prigionieri
- F. Fermi di fissaggio (solo S-TYPE e X-TYPE)

Contenido del kit

- A. Red
- B. Ganchos de fijación para la moqueta
- C. Ganchos de fijación para los paneles
- D. Tachuelas de fijación para los paneles
- E. Tachuelas
- F. Clips de sujeción (S-TYPE y X-TYPE solamente)

キット内容

- A. ネット
- B. カーペット固定フック
- C. ボード固定フック
- D. ボード固定スタッド
- E. スタッド
- F. 固定クリップ
(S-TYPE および X-TYPE のみ)

Notes: Hinweise: Note: Nota: 注

- 1*,2*,3*,4*. Recommended fitting positions.
- 1*,2*,3*,4*. Positions de montage recommandées.
- 1*,2*,3*,4*. Empfohlene Montageposition.
- 1*,2*,3*,4*. Posizioni di montaggio suggerite.
- 1*,2*,3*,4*. Posición de montaje recomendada.
- 1*,2*,3*,4*. 固定位置の例。

- 1a-6a. 1b-15b. 1c-5c. XJ Series
- 1d-6d. 1e-16e. XK Series
- 1f-6f. 1g-7g. S-TYPE
- 1h-6h. 1j-7j. X-TYPE
- 1k-6k The XJ, La XJ, Der XJ, XJ

Notes: Hinweise: Note: Nota: 注

Fixings remaining from the installation may be used elsewhere to provide an alternative location for the net. Refer to drawings * for suitable locations.

Les fixations en surplus peuvent être utilisées pour l'installation du filet à un autre emplacement. Se reporter aux illustrations * pour les emplacements appropriés.

Die restlichen Befestigungen vom Einbau können zur Befestigung des Gepäcknetzes an anderer Stelle verwendet werden. Siehe Abb. * für geeignete Befestigungsstellen.

Gli elementi di fissaggio rimasti possono essere utilizzati per montare la retina in una posizione alternativa. Per altre posizioni di fissaggio adatte, vedere le figure *.

Las fijaciones que no se hayan utilizado durante el montaje pueden usarse para proporcionar diferentes posiciones de la red en cualquier otro lugar. Remítase a los gráficos * para comprobar las posiciones adecuadas.

取り付けに使用しなかった固定具は、ネットの位置を変えたい場合に異なる場所に使用することが出来ます。適切な場所については、図 * を参照してください。

SK1R83-F046C04AC

MY 1998 →

Part No. C2A 1408

XJ Series

Car Tidy Net, Filet de rangement, Gepäcknetz, Retina portaoggetti, Red de almacenamiento, 車両用整頓ネット

Notes: Hinweise: Note: Nota: 注

- 1*. Recommended fitting positions. Passenger side gearbox cover.
- 1*. Positions de montage recommandées. Housse de boîte de vitesse côté passager.
- 1*. Empfohlene Einbauposition. Getriebegehäuse, Beifahrerseite.
- 1*. Posizioni di montaggio suggerite. Coperchio cambio velocità lato passeggero.
- 1*. Posición de montaje recomendada. Cubierta de la caja de cambios, lado del pasajero.
- 1*. 固定位置の例。助手席側ギヤボックス カバー。

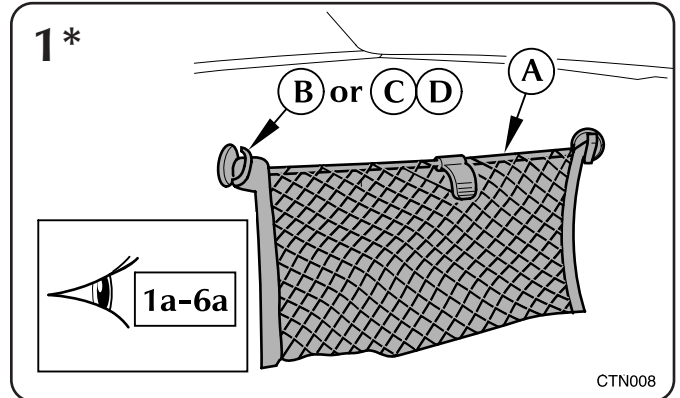

Notes: Hinweise: Note: Nota: 注

- 2*. Recommended fitting positions. RH & LH Rear seat heelboard.
- 2*. Positions de montage recommandées. Planche à talon banquette arrière côtés gauche et droit.
- 2*. Empfohlene Einbauposition. Rücksitz-Fersenblechabdeckung, rechts/links.
- 2*. Posizioni di montaggio suggerite. Vano piede sedili posteriori sinistro e destro.
- 2*. Posición de montaje recomendada. Espacio para los pies, asientos traseros derecho e izquierdo.
- 2*. 固定位置の例。RH及びLHリアシートヒールボード。

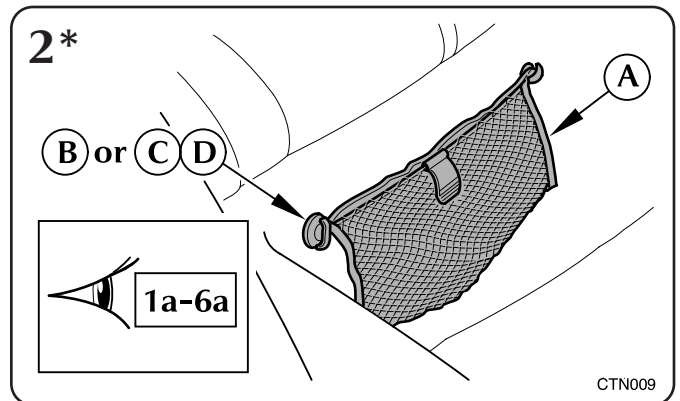

Notes: Hinweise: Note: Nota: 注

- 3*. Recommended fitting positions. Trunk for XJ Series.
- 3*. Positions recommandées. Coffre à bagages de la Série XJ.
- 3*. Empfohlene Einbauposition. Kofferraum bei XJ Fahrzeugen.
- 3*. Posizioni di fissaggio consigliate. Bagagliaio per Serie XJ.
- 3*. Posiciones de montaje recomendadas. Maletero para los vehículos de la serie XJ.
- 3*. 推奨される取り付け位置。XJ Series のトランク。

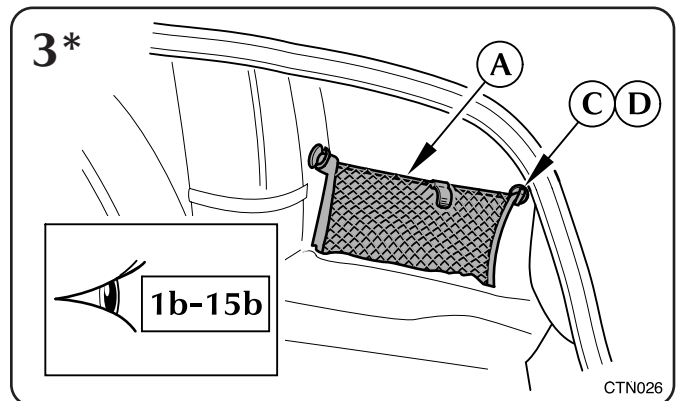

Notes: Hinweise: Note: Nota: 注

- 4*. Recommended fitting positions. Trunk for XJ Series.
- 4*. Positions recommandées. Coffre à bagages de la Série XJ.
- 4*. Empfohlene Einbauposition. Kofferraum bei XJ Fahrzeugen.
- 4*. Posizioni di fissaggio consigliate. Bagagliaio per Serie XJ.
- 4*. Posiciones de montaje recomendadas. Maletero para los vehículos de la serie XJ.
- 4*. 推奨される取り付け位置。XJ Series のトランク。

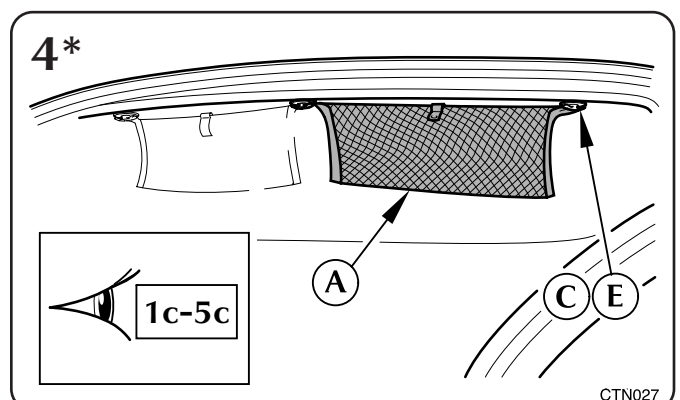



FITTING INSTRUCTIONS, INSTRUCTIONS DE MONTAGE,
EINBAUANLEITUNG, ISTRUZIONI DI MONTAGGIO,
INSTRUCCIONES DE MONTAJE, 取扱説明書

XJ Series
(a)

Car Tidy Net, Filet de rangement, Gepäcknetz,
Retina portaoggetti, Red de almacenamiento,
車両用整頓ネット

1a

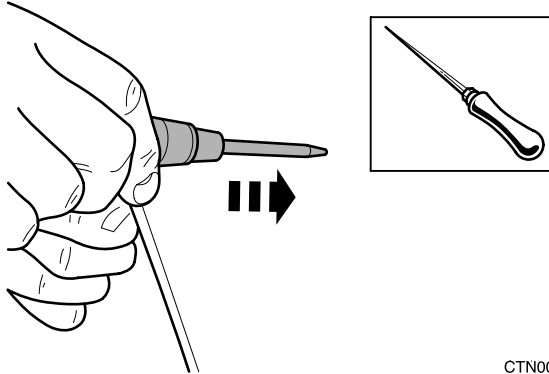

CTN002

2a

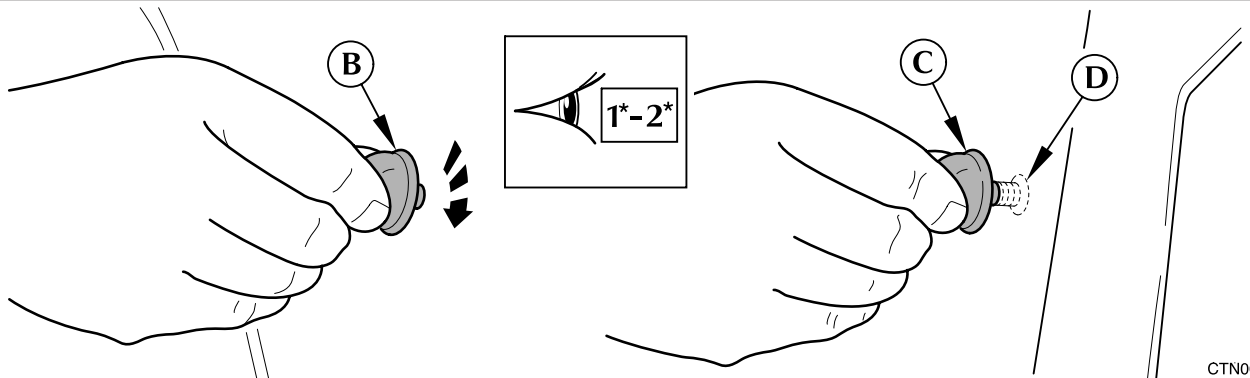

CTN003

3a

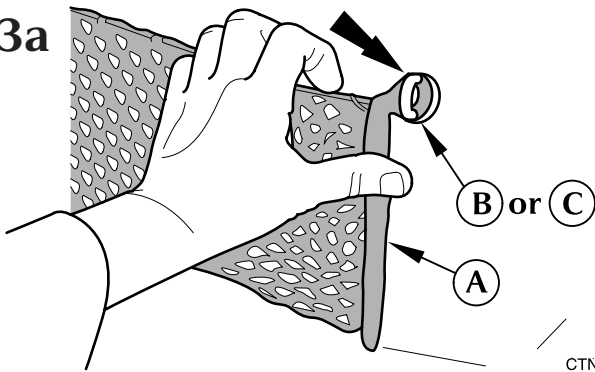

CTN004

4a

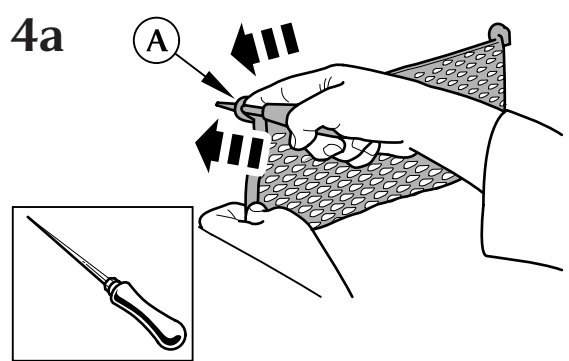

CTN005

5a

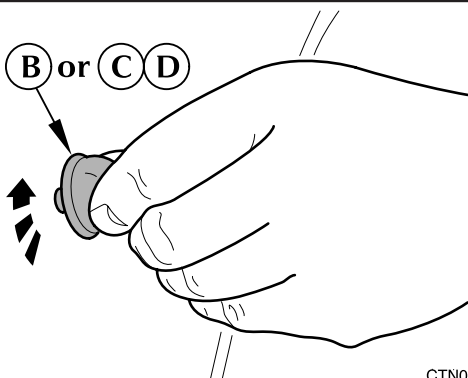

CTN006

6a

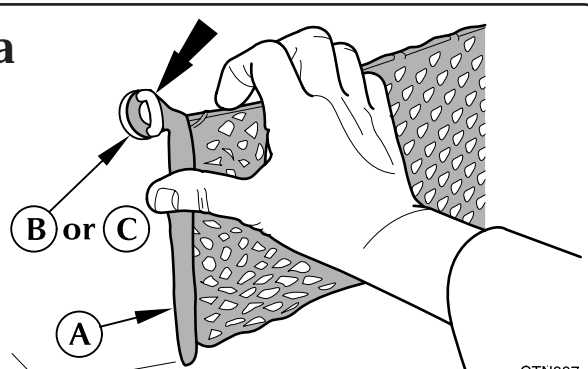

CTN007

MY 1998 →

Part No. C2A 1408



FITTING INSTRUCTIONS, INSTRUCTIONS DE MONTAGE,
EINBAUANLEITUNG, ISTRUZIONI DI MONTAGGIO,
INSTRUCCIONES DE MONTAJE, 取扱説明書

**XJ Series
(b)**

**Car Tidy Net, Filet de rangement, Gepäcknetz,
Retina portaoggetti, Red de almacenamiento,
車両用整頓ネット**

Notes: Note: Hinweise: Nota: 注

- 1b-15b. Fitting net into trunk for V8/XJ Series.
- 1b-15b. Pose du filet dans le coffre à bagages de la Série V8/XJ.
- 1b-15b. Einbau des Gepäcknetzes - Kofferraum für V8/XJ Fahrzeuge.
- 1b-15b. Montaggio retina nel bagagliaio per Serie V8/XJ.
- 1b-15b. Montaje de la red en el maletero en vehículos de la serie XJ/V8.
- 1b-15b. V8/XJシリーズのトランクにネットを固定。

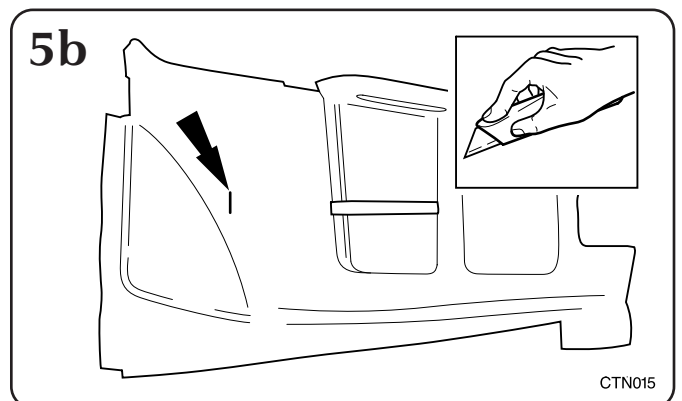
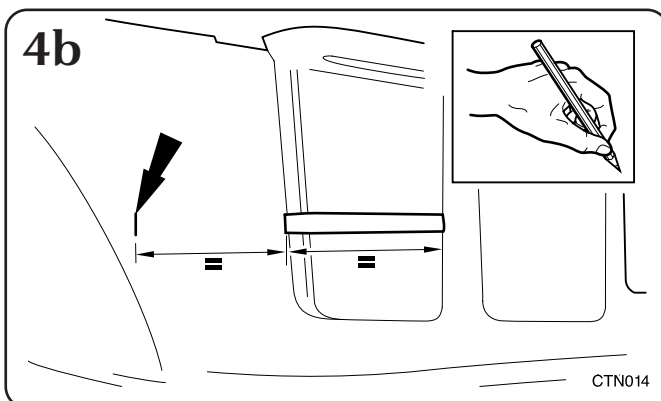
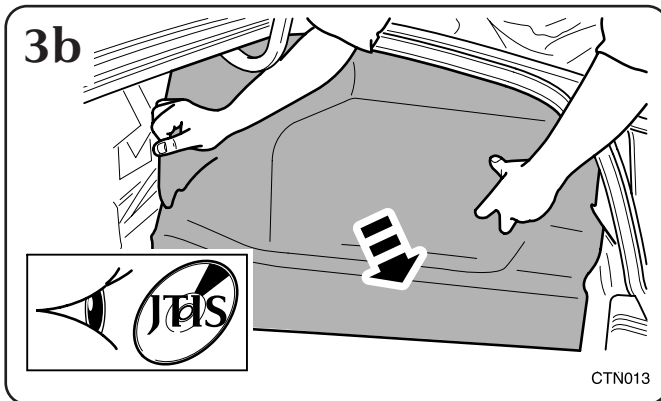
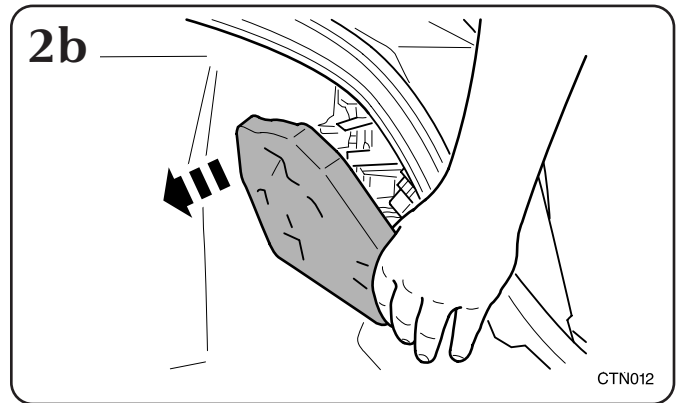
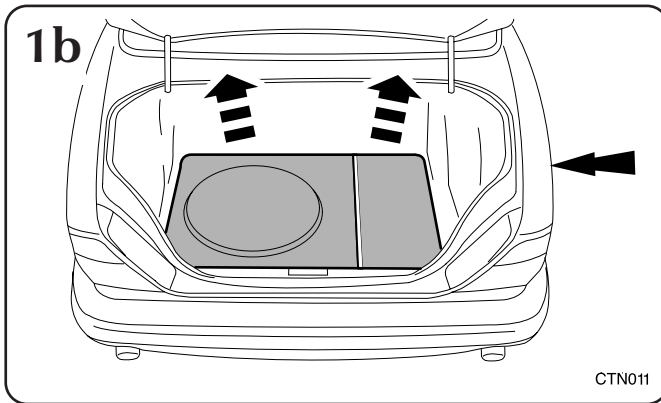

MY 1998 →

Part No. C2A 1408

**XJ Series
 (b)**

**Car Tidy Net, Filet de rangement, Gepäcknetz,
 Retina portaoggetti, Red de almacenamiento,
 車両用整頓ネット**

6b

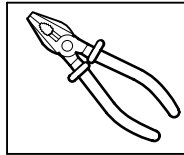
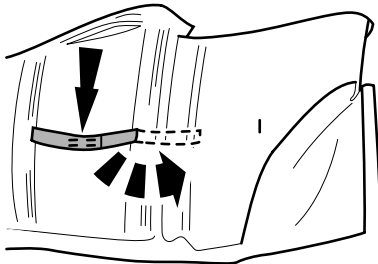

CTN016

Notes: Hinweise: Note: Nota: 注

- 6b. Remove staple fasteners.
- 6b. Déposer les agrafes.
- 6b. Klammern entfernen.
- 6b. Rimuovere le graffette.
- 6b. Retire las grapas.
- 6b. ステープル ファスナーを取り外します。

7b

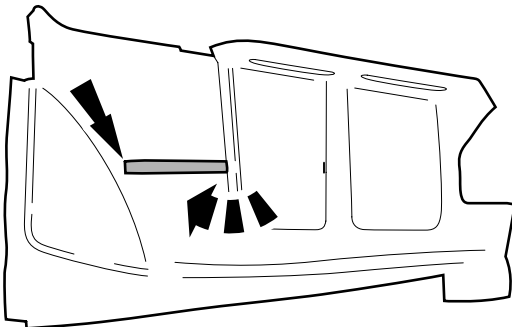

CTN017

8b

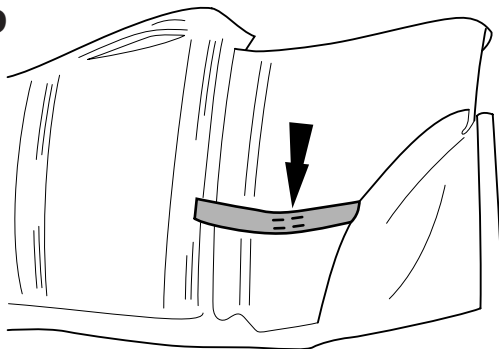

CTN018

Notes: Hinweise: Note: Nota: 注

- 8b. Re-staple strap.
- 8b. Agrafar de nouveau la sangle.
- 8b. Halteband klammern.
- 8b. Fissare nuovamente la fascetta.
- 8b. Vuelva a fijar con grapas la abrazadera.
- 8b. ストラップをステープルで再び固定します。

9b

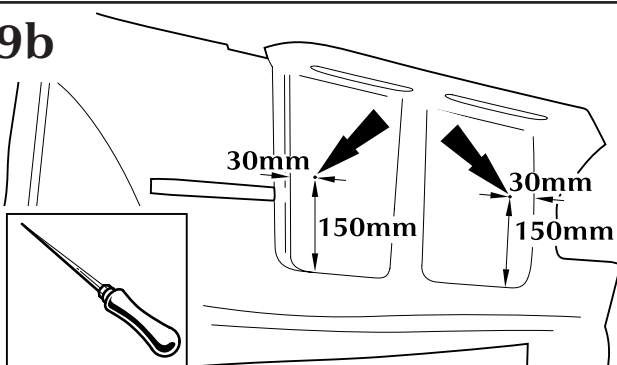

CTN019

10b

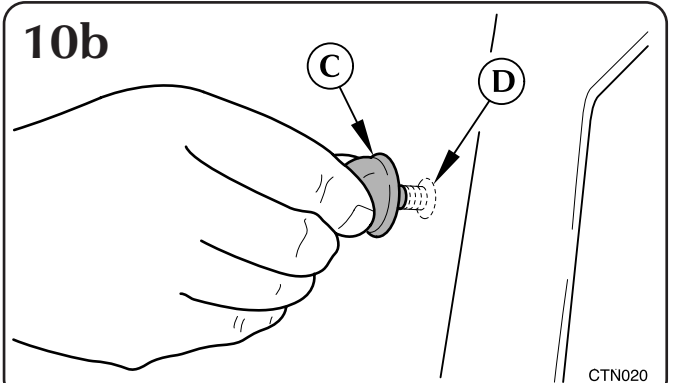

CTN020

MY 1998 →

Part No. C2A 1408



FITTING INSTRUCTIONS, INSTRUCTIONS DE MONTAGE,
EINBAUANLEITUNG, ISTRUZIONI DI MONTAGGIO,
INSTRUCCIONES DE MONTAJE, 取扱説明書

XJ Series
(b)

Car Tidy Net, Filet de rangement, Gepäcknetz,
Retina portaoggetti, Red de almacenamiento,
車両用整頓ネット

11b

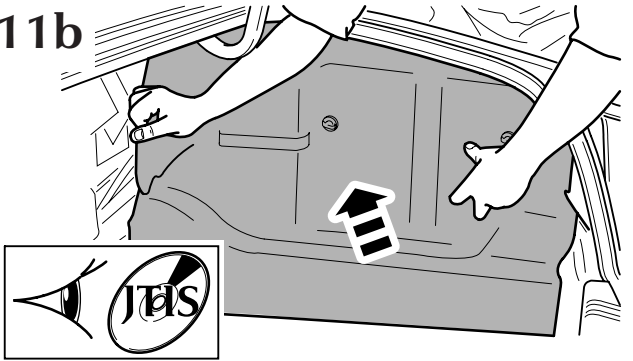

CTN021

12b

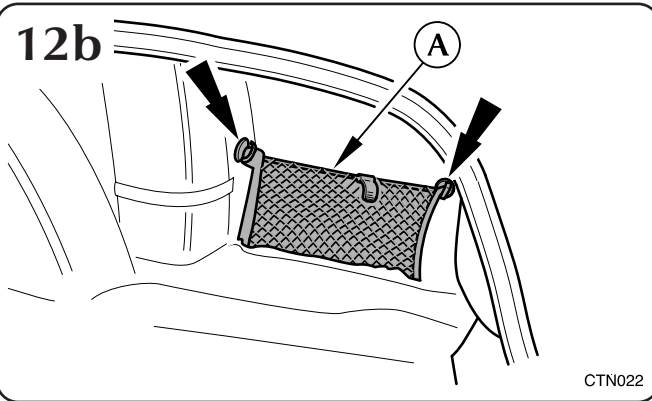

CTN022

13b

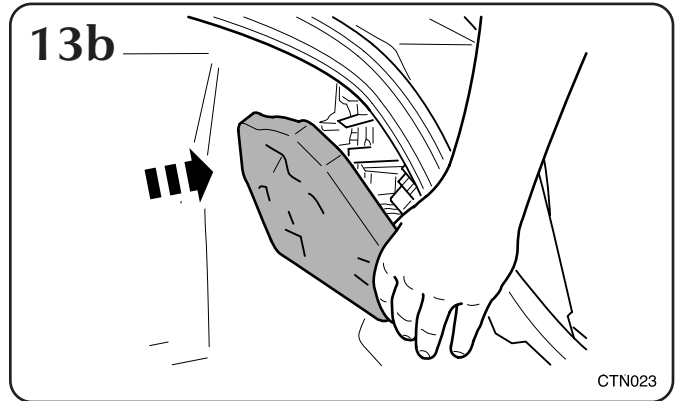

CTN023

14b

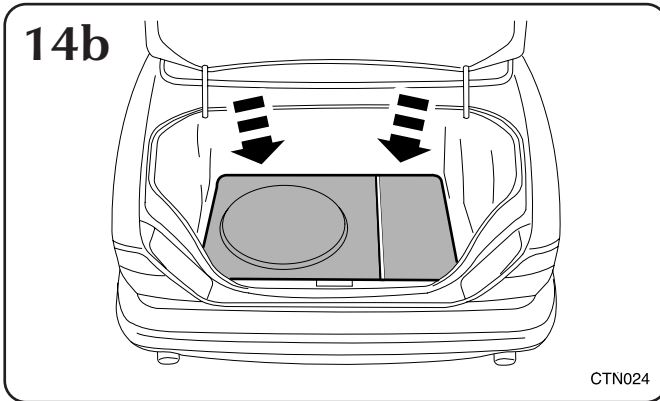

CTN024

15b

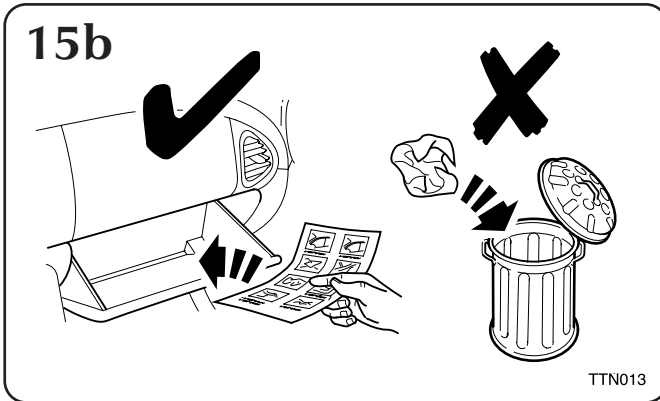

TTN013

MY 1998 →

Part No. C2A 1408



FITTING INSTRUCTIONS, INSTRUCTIONS DE MONTAGE,
 EINBAUANLEITUNG, ISTRUZIONI DI MONTAGGIO,
 INSTRUCCIONES DE MONTAJE, 取扱説明書

XJ Series
 (c)

Car Tidy Net, Filet de rangement, Gepäcknetz,
 Retina portaoggetti, Red de almacenamiento,
 車両用整頓ネット

1c

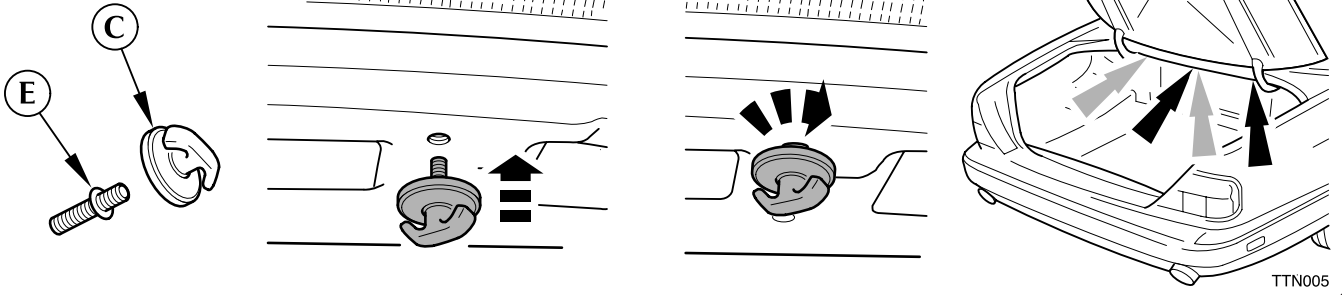

TTN005

2c

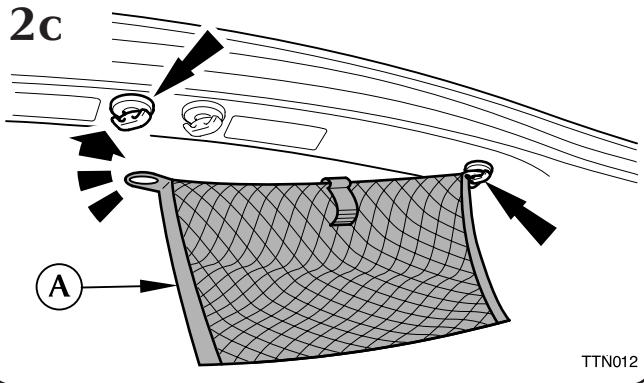

TTN012

3c

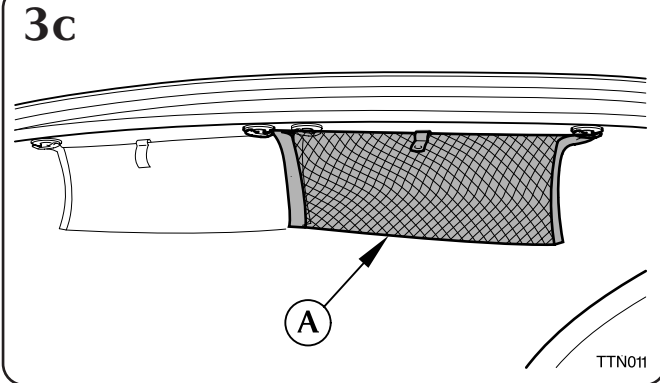

TTN011

4c

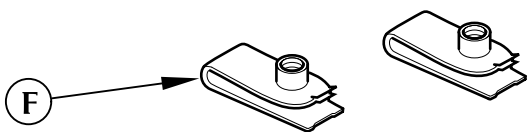

TTN014

Notes: Hinweise: Note: Nota: 注

- 4c. Items (F) should be retained for use on S-TYPE or X-TYPE.
- 4c. Conserver les éléments (F) pour utilisation sur la S-TYPE ou la X-TYPE.
- 4c. Teile (F) sind für die Verwendung bei S-TYPE und X-TYPE Fahrzeugen aufzubewahren.
- 4c. Conservare gli elementi F per l'utilizzo sui veicoli S-TYPE o X-TYPE.
- 4c. Los elementos (F) se deben guardar para los vehículos de la serie S-TYPE o X-TYPE.
- 4c. **S-TYPE** または **X-TYPE** に使用する場合に固定すべアイテム(F)。

5c



TTN013

MY 1998 →

Part No. C2A 1408

XK Series

Car Tidy Net, Filet de rangement, Gepäcknetz, Retina portaoggetti, Red de almacenamiento, 車両用整頓ネット

Notes: Hinweise: Note: Nota: 注

- 1*. Recommended fitting positions. Passenger side gearbox cover.
- 1*. Positions de montage recommandées. Housse de boîte de vitesse côté passager.
- 1*. Empfohlene Einbauposition. Getriebegehäuse, Beifahrerseite.
- 1*. Posizioni di montaggio suggerite. Coperchio cambio velocità lato passeggero.
- 1*. Posición de montaje recomendada. Cubierta de la caja de cambios, lado del pasajero.
- 1*. 固定位置の例。助手席側ギヤボックス カバー。

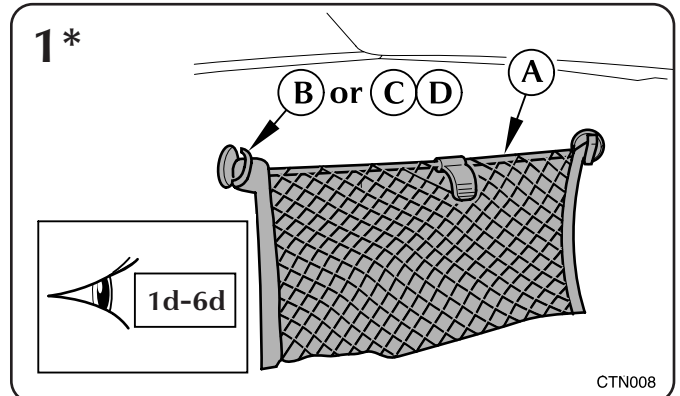

Notes: Hinweise: Note: Nota: 注

- 2*. Recommended fitting positions. RH & LH Rear seat heelboard.
- 2*. Positions de montage recommandées. Planche à talon banquette arrière côtés gauche et droit.
- 2*. Empfohlene Einbauposition. Rücksitz-Fersenblechabdeckung, rechts/links.
- 2*. Posizioni di montaggio suggerite. Vano piede sedili posteriori sinistro e destro.
- 2*. Posición de montaje recomendada. Espacio para los pies, asientos traseros derecho e izquierdo.
- 2*. 固定位置の例。RH及びLHリアシートヒールボード。

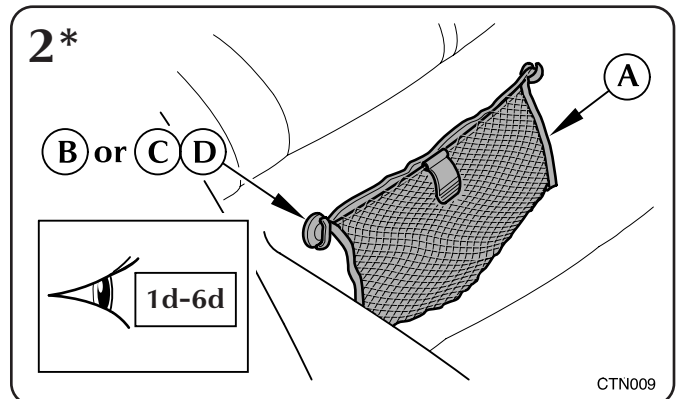

Notes: Hinweise: Note: Nota: 注

- 3*. Recommended fitting positions. Trunk for XK Series.
- 3*. Positions recommandées. Coffre à bagages de la Série XK.
- 3*. Empfohlene Einbauposition. Kofferraum bei XK Fahrzeugen.
- 3*. Posizioni di fissaggio consigliate. Bagagliaio per Serie XK.
- 3*. Posiciones de montaje recomendadas. Maletero para los vehículos de la serie XK.
- 3*. 推奨される取り付け位置。XK Series のトランク。

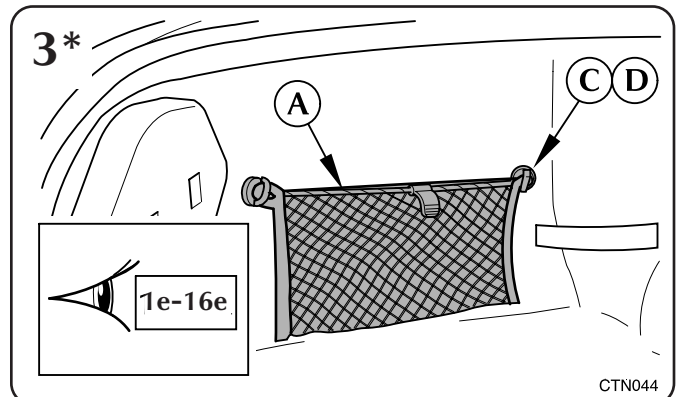

**XK Series
 (d)**

**Car Tidy Net, Filet de rangement, Gepäcknetz,
 Retina portaoggetti, Red de almacenamiento,
 車両用整頓ネット**

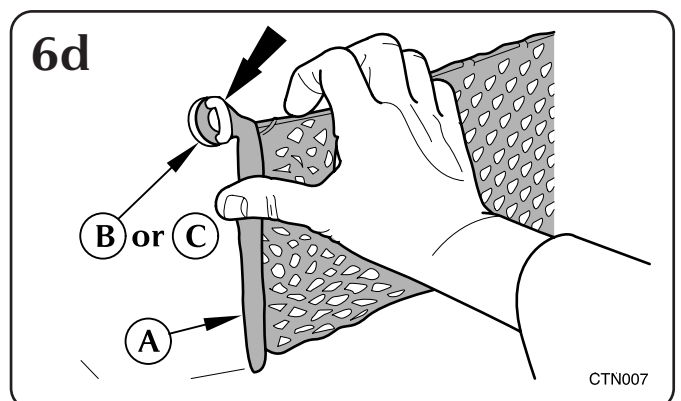
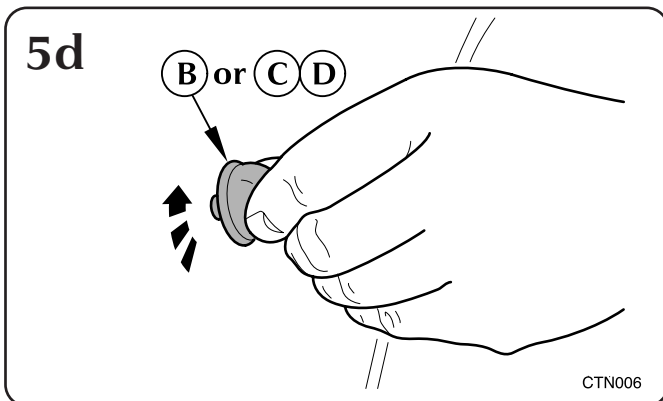
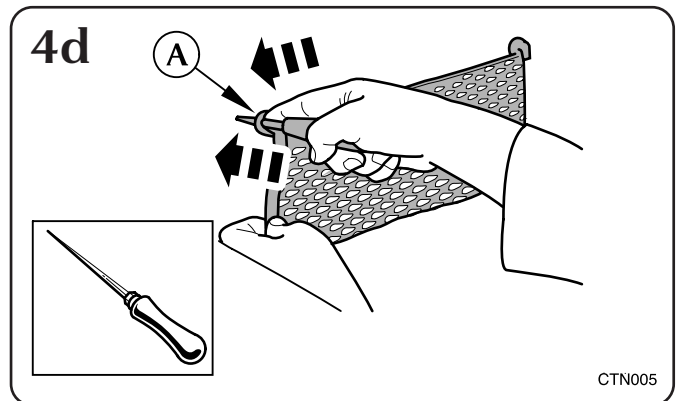
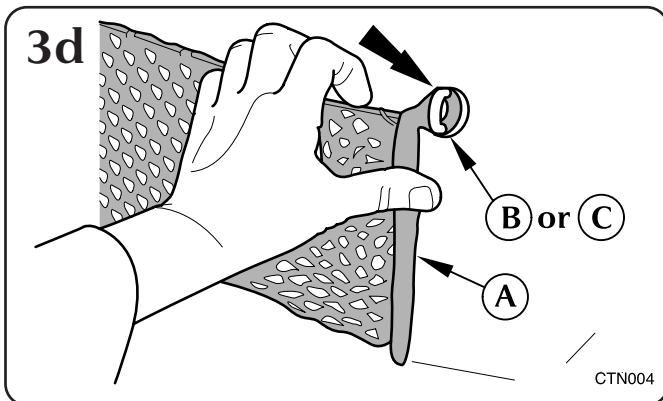
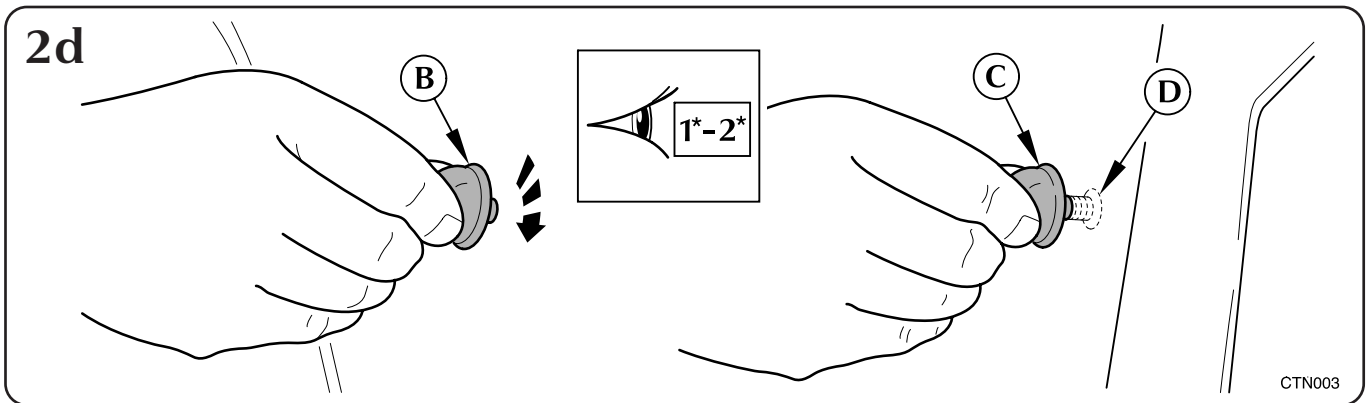
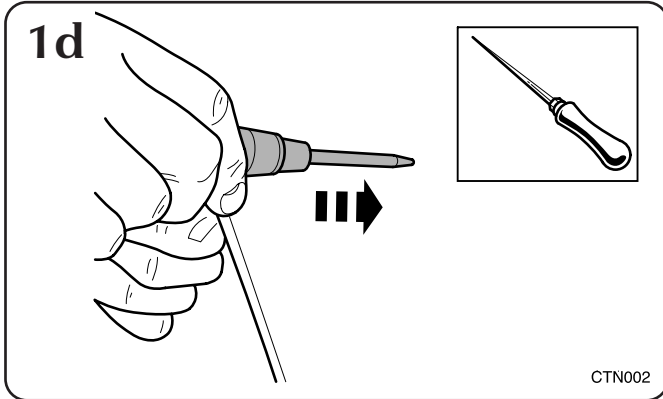



FITTING INSTRUCTIONS, INSTRUCTIONS DE MONTAGE,
EINBAUANLEITUNG, ISTRUZIONI DI MONTAGGIO,
INSTRUCCIONES DE MONTAJE, 取扱説明書

**XK Series
(e)**

**Car Tidy Net, Filet de rangement, Gepäcknetz,
Retina portaoggetti, Red de almacenamiento,
車両用整頓ネット**

Notes: Note: Hinweise: Nota: 注

- 1e-16e. Fitting net into trunk for XK Series.
- 1e-16e. Pose du filet dans le coffre à bagages de la Série XK.
- 1e-16e. Einbau des Gepäcknetzes - Kofferraum für XK Fahrzeuge.
- 1e-16e. Montaggio retina nel bagagliaio per Serie XK.
- 1e-16e. Montaje de la red en el maletero en vehículos de la serie XK.
- 1e-16e. **XK Series** のトランクへのネット取付け手順。

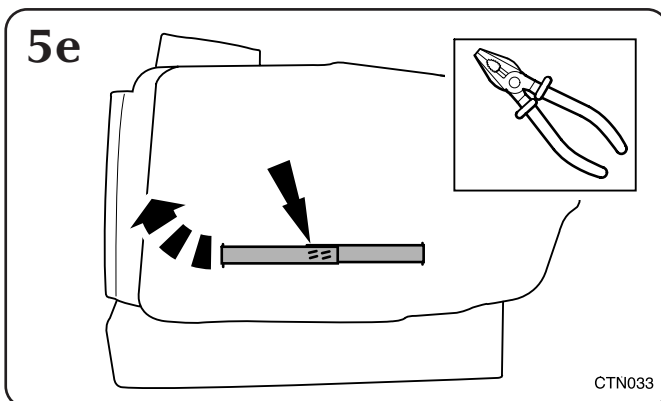
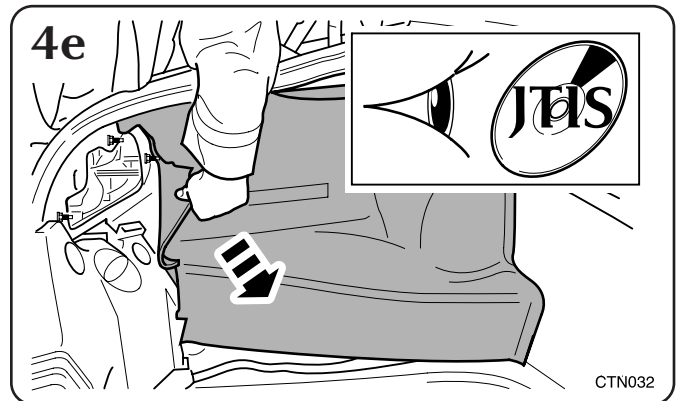
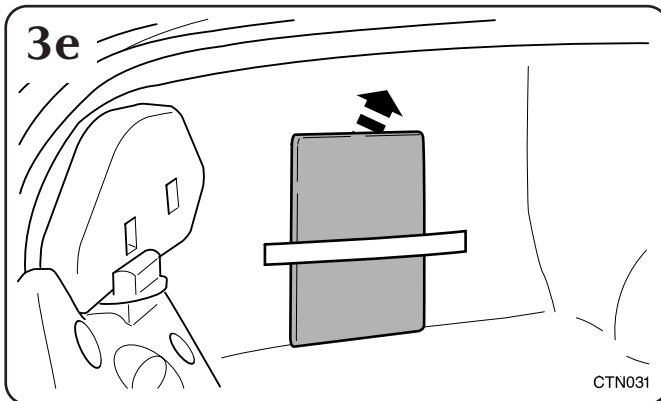
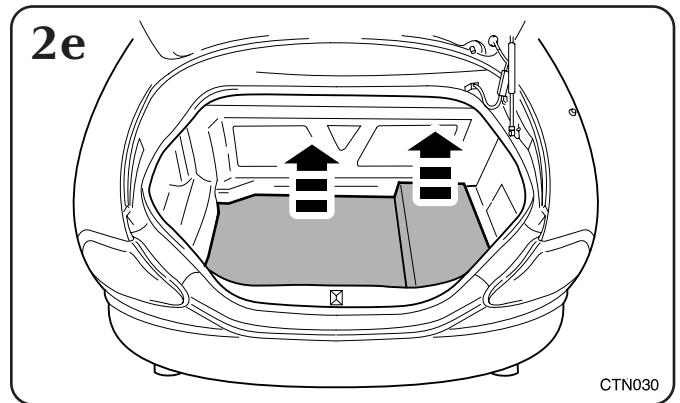
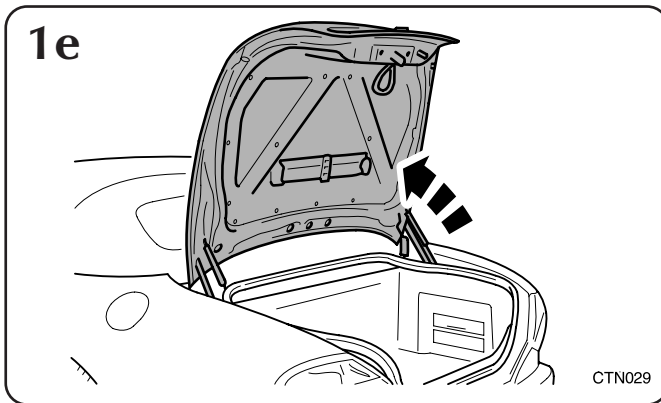

Notes: Hinweise: Note: Nota: 注

- 5e. Remove staple fasteners.
- 5e. Déposer les agrafes.
- 5e. Klammern entfernen.
- 5e. Rimuovere le graffette.
- 5e. Retire las grapas.
- 5e. ステープル ファスナーを取り外します。

MY 1998 →

Part No. C2A 1408



FITTING INSTRUCTIONS, INSTRUCTIONS DE MONTAGE,
EINBAUANLEITUNG, ISTRUZIONI DI MONTAGGIO,
INSTRUCCIONES DE MONTAJE, 取扱説明書

XK Series
(e)

Car Tidy Net, Filet de rangement, Gepäcknetz,
Retina portaoggetti, Red de almacenamiento,
車両用整頓ネット

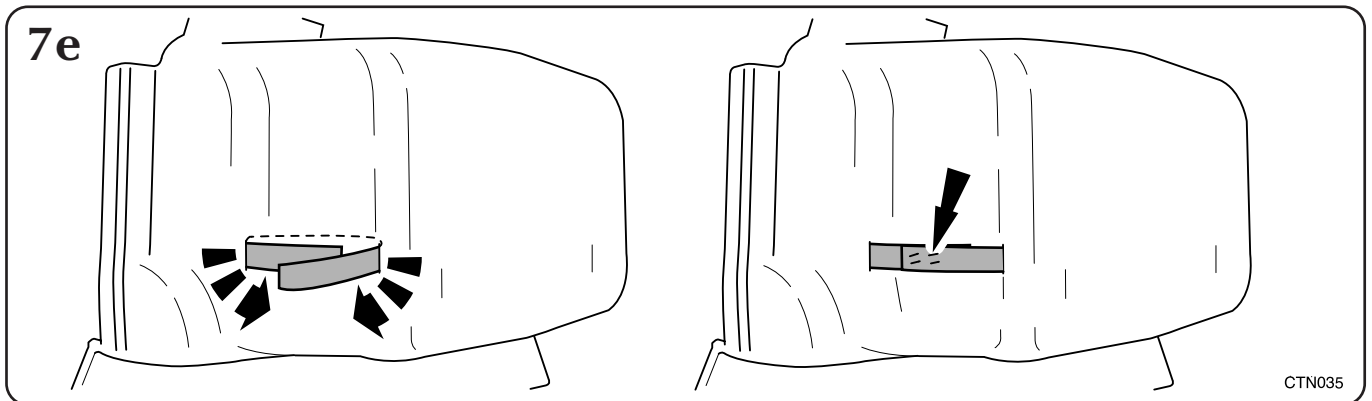
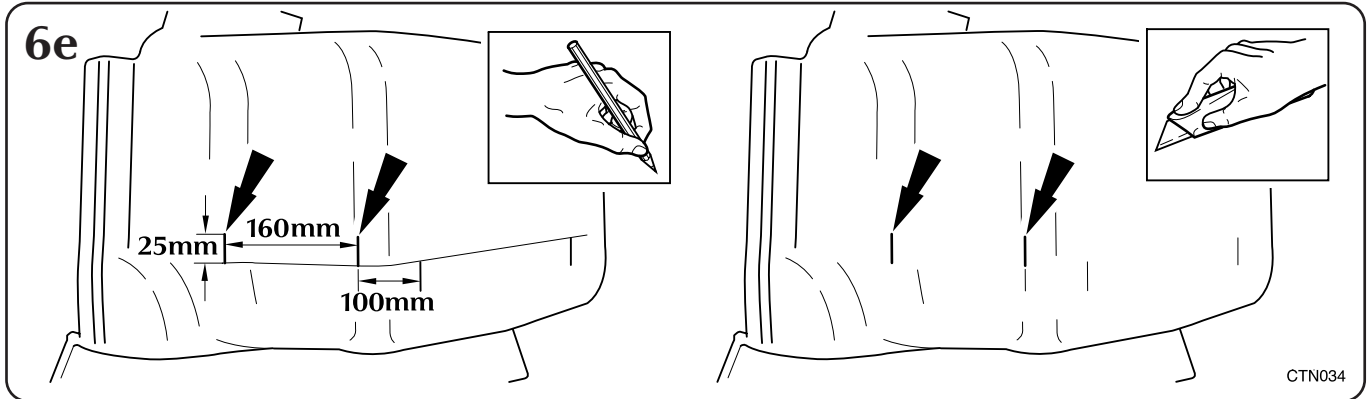

Notes: Hinweise: Note: Nota: 注

- 7e. Re-staple strap.
- 7e. Agrafer de nouveau la sangle.
- 7e. Halteband klammern.
- 7e. Fissare nuovamente la fascetta.
- 7e. Vuelva a fijar con grapas la abrazadera.
- 7e. ストラップをステープルで再び固定します。

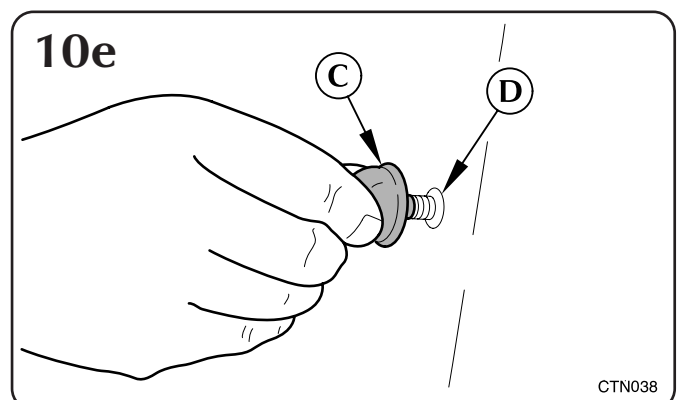
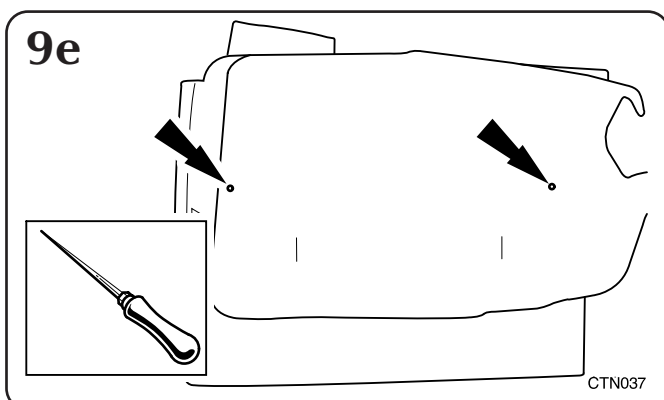
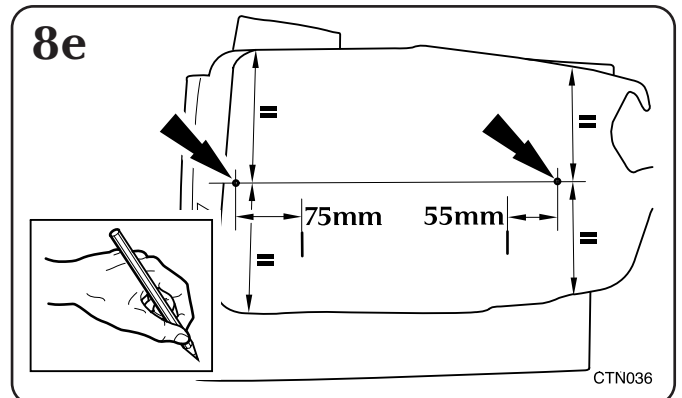

MY 1998 →

Part No. C2A 1408



FITTING INSTRUCTIONS, INSTRUCTIONS DE MONTAGE,
EINBAUANLEITUNG, ISTRUZIONI DI MONTAGGIO,
INSTRUCCIONES DE MONTAJE, 取扱説明書

XK Series
(e)

Car Tidy Net, Filet de rangement, Gepäcknetz,
Retina portaoggetti, Red de almacenamiento,
車両用整頓ネット

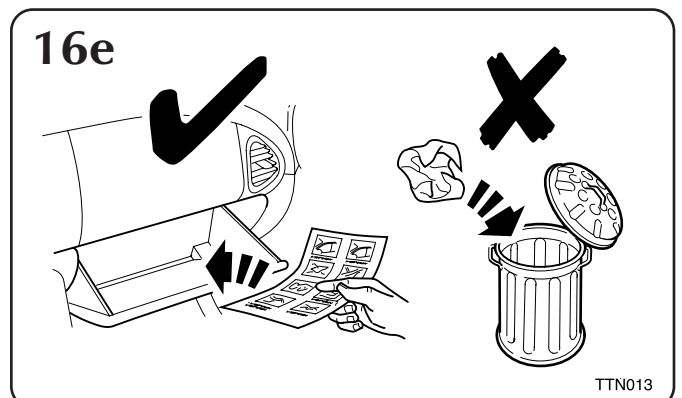
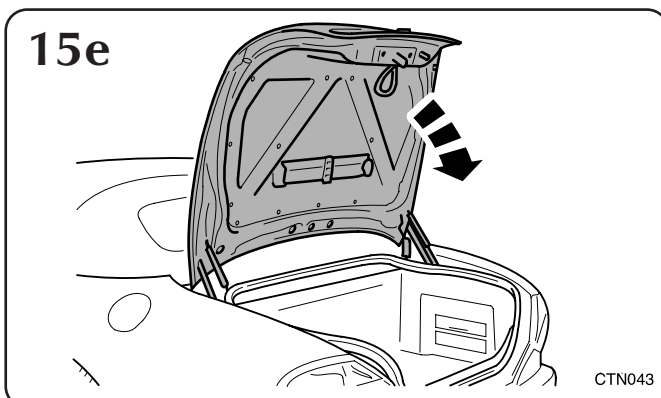
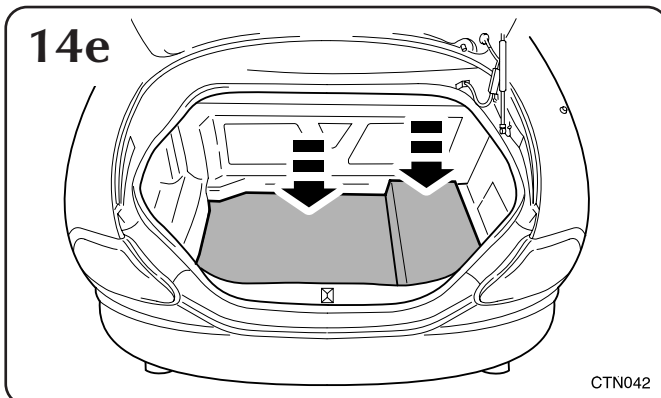
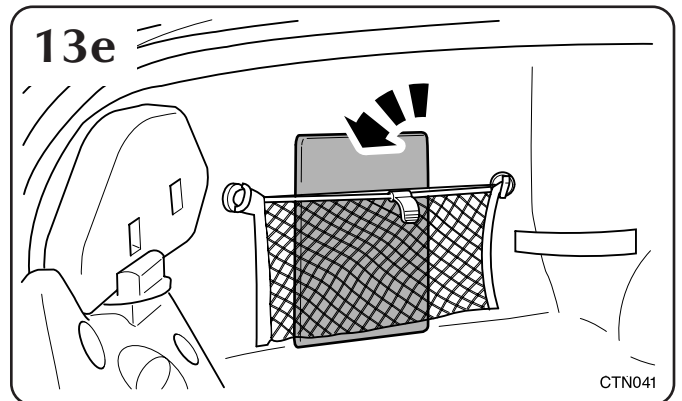
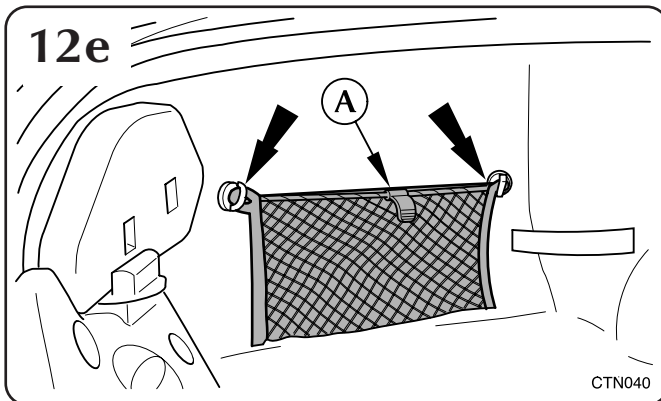
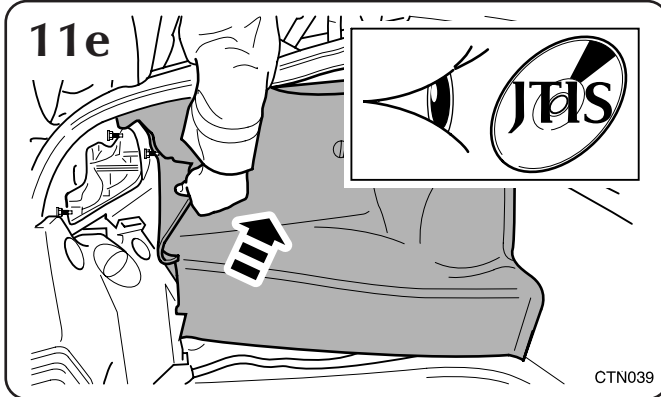

MY 1998 →

Part No. C2A 1408

S-TYPE

Car Tidy Net, Filet de rangement, Gepäcknetz, Retina portaoggetti, Red de almacenamiento, 車両用整頓ネット

Notes: Hinweise: Note: Nota: 注

- 1*. Recommended fitting positions. Passenger side gearbox cover.
- 1*. Positions de montage recommandées. Housse de boîte de vitesse côté passager.
- 1*. Empfohlene Einbauposition. Getriebegehäuse, Beifahrerseite.
- 1*. Posizioni di montaggio suggerite. Coperchio cambio velocità lato passeggero.
- 1*. Posición de montaje recomendada. Cubierta de la caja de cambios, lado del pasajero.
- 1*. 固定位置の例。助手席側ギヤボックス カバー。

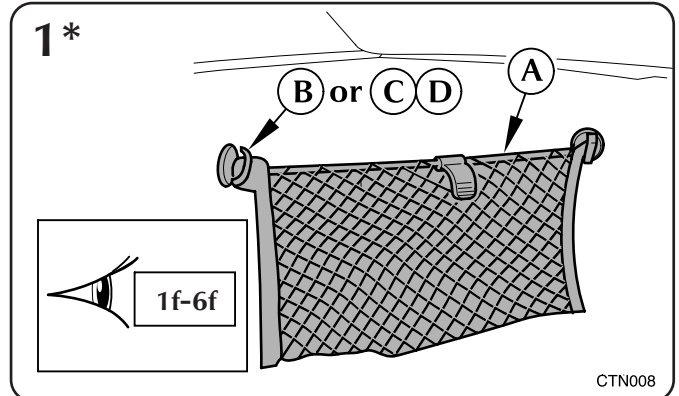

Notes: Hinweise: Note: Nota: 注

- 2*. Recommended fitting positions. RH & LH Rear seat heelboard.
- 2*. Positions de montage recommandées. Planche à talon banquette arrière côtés gauche et droit.
- 2*. Empfohlene Einbauposition. Rücksitz-Fersenblechabdeckung, rechts/links.
- 2*. Posizioni di montaggio suggerite. Vano piede sedili posteriori sinistro e destro.
- 2*. Posición de montaje recomendada. Espacio para los pies, asientos traseros derecho e izquierdo.
- 2*. 固定位置の例。RH及びLHリアシートヒールボード。

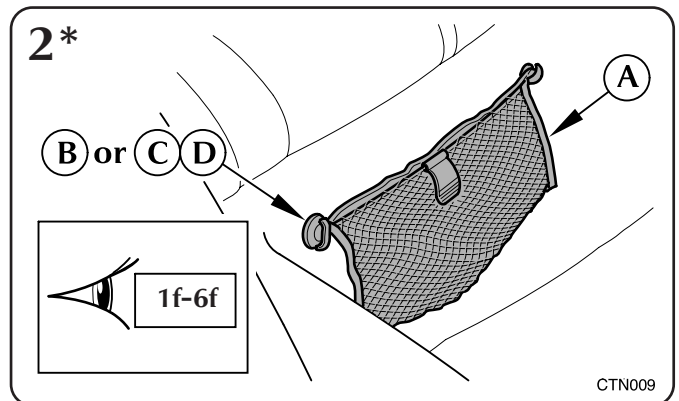

Notes: Hinweise: Note: Nota: 注

- 3*. Recommended fitting positions. Trunk for S-TYPE.
- 3*. Positions recommandées. Coffre à bagages de la S-TYPE.
- 3*. Empfohlene Einbauposition. Kofferraum bei S-TYPE.
- 3*. Posizioni di fissaggio consigliate. Bagagliaio per S-TYPE.
- 3*. Posiciones de montaje recomendadas. Maletero para los vehículos de la serie S-TYPE.
- 3*. 推奨される取り付け位置。S-TYPE および。

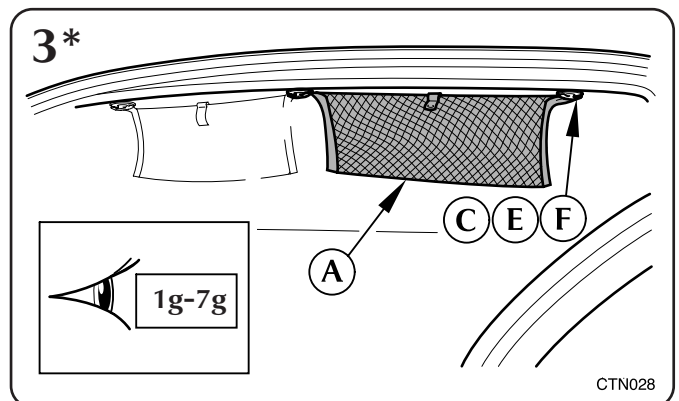

S-TYPE
(f)

Car Tidy Net, Filet de rangement, Gepäcknetz,
 Retina portaoggetti, Red de almacenamiento,
 車両用整頓ネット

1f

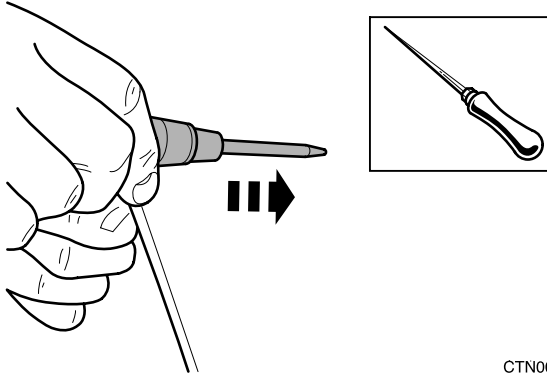

CTN002

2f

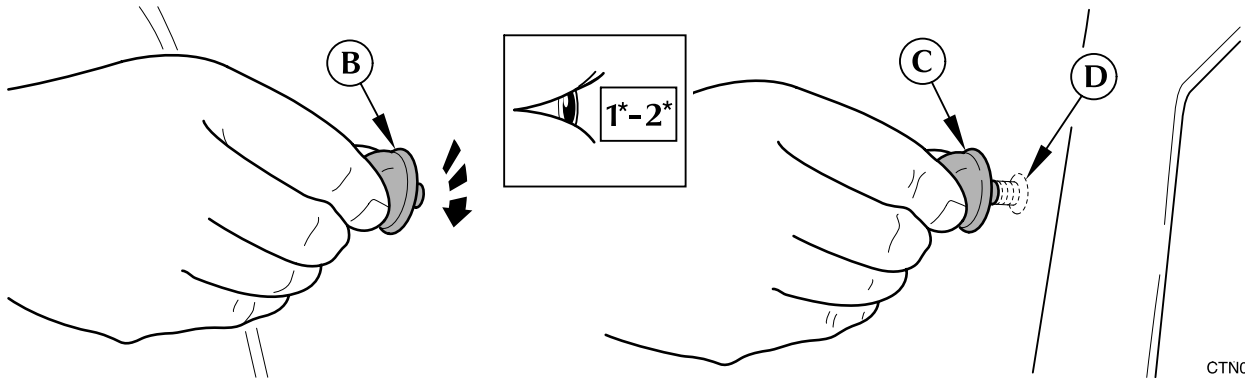

CTN003

3f

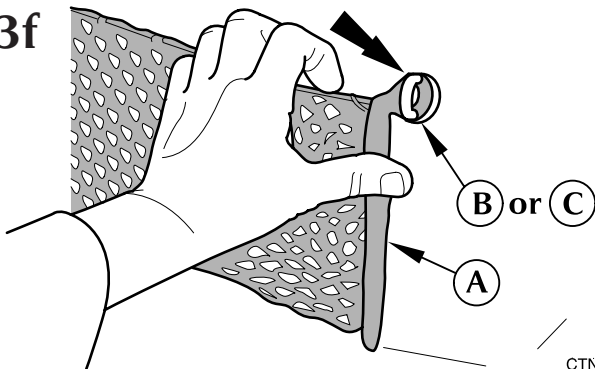

CTN004

4f

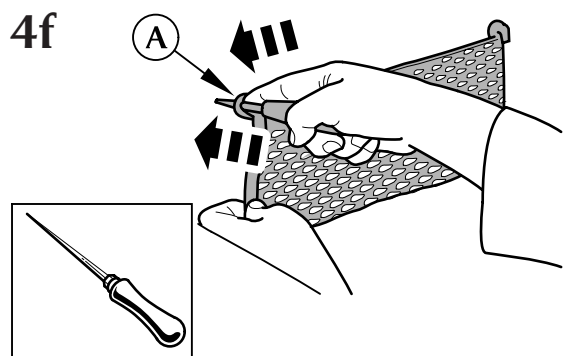

CTN005

5f

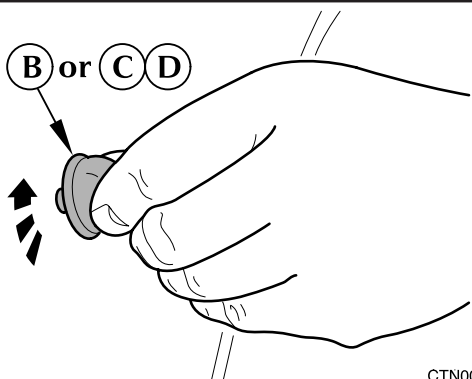

CTN006

6f

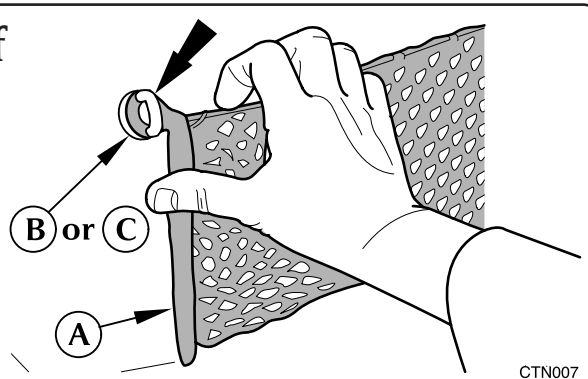

CTN007



FITTING INSTRUCTIONS, INSTRUCTIONS DE MONTAGE,
EINBAUANLEITUNG, ISTRUZIONI DI MONTAGGIO,
INSTRUCCIONES DE MONTAJE, 取扱説明書

S-TYPE
(g)

Car Tidy Net, Filet de rangement, Gepäcknetz,
Retina portaoggetti, Red de almacenamiento,
車両用整頓ネット

1g

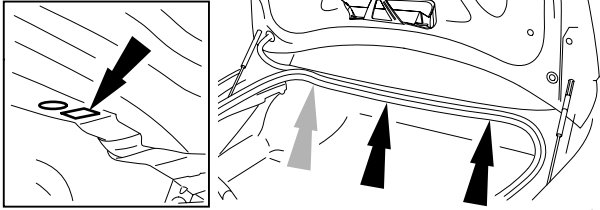

2g

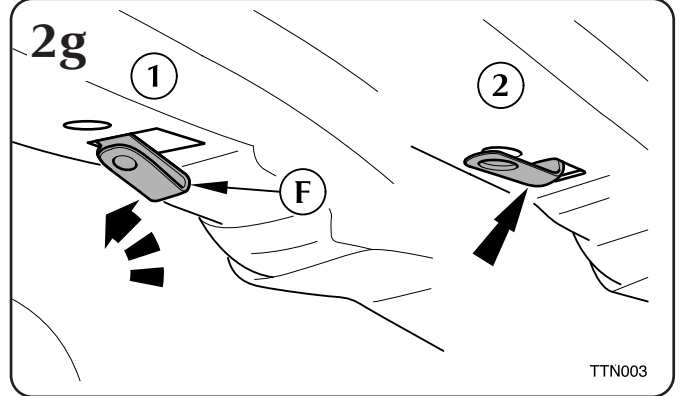

3g

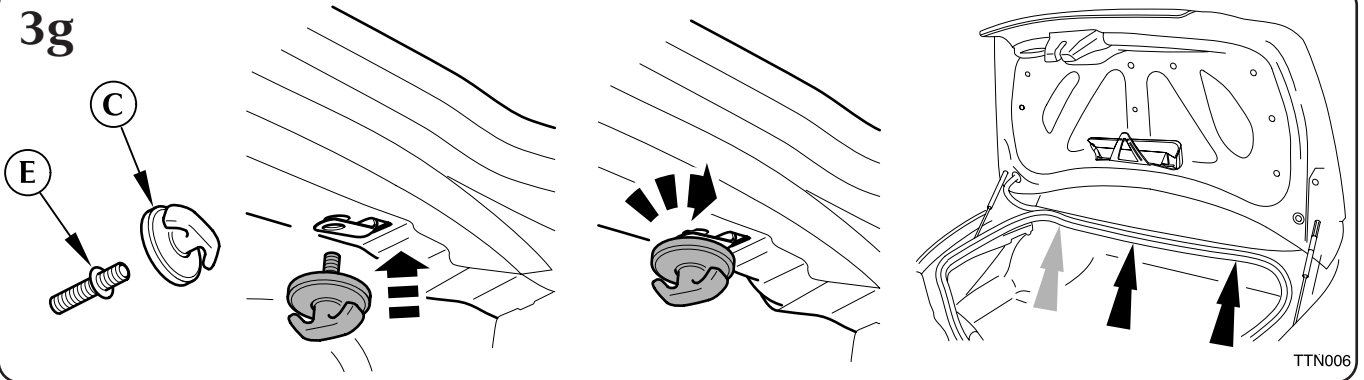

4g

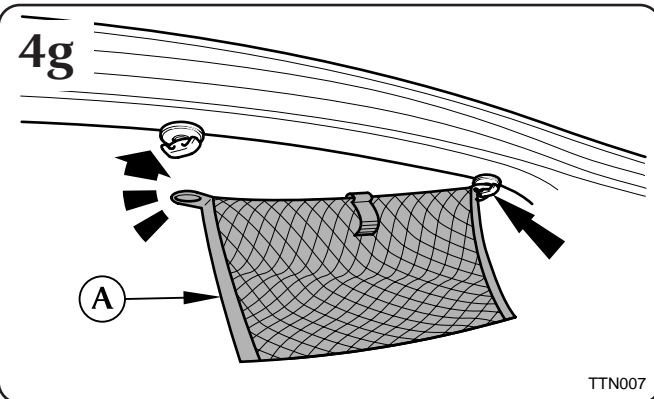

5g

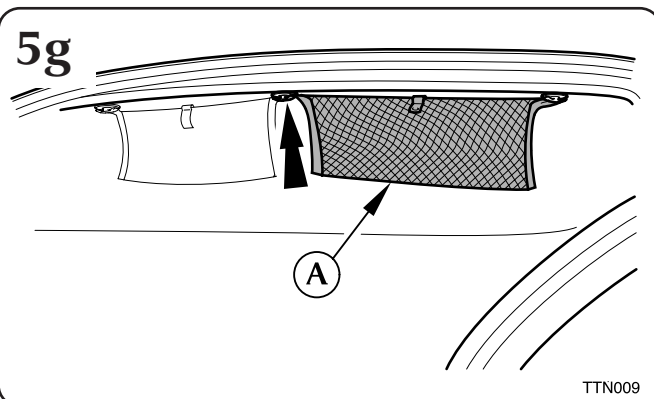

6g

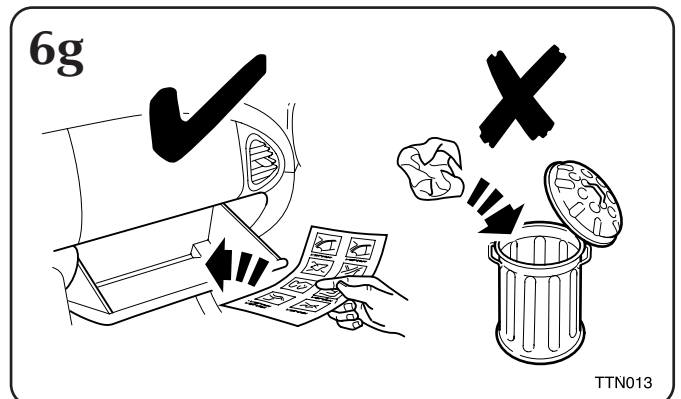

MY 1999 →

Part No. C2A 1408

X-TYPE

Car Tidy Net, Filet de rangement, Gepäcknetz, Retina portaoggetti, Red de almacenamiento, 車両用整頓ネット

Notes: Hinweise: Note: Nota: 注

- 1*. Recommended fitting positions. RH & LH Rear seat heelboard.
- 1*. Positions de montage recommandées. Planche à talon banquette arrière côtés gauche et droit.
- 1*. Empfohlene Einbauposition. Rücksitz-Fersenblechabdeckung, rechts/links.
- 1*. Posizioni di montaggio suggerite. Vano piede sedili posteriori sinistro e destro.
- 1*. Posición de montaje recomendada. Espacio para los pies, asientos traseros derecho e izquierdo.
- 1*. 固定位置の例。RH及びLHリアシートヒールボード。

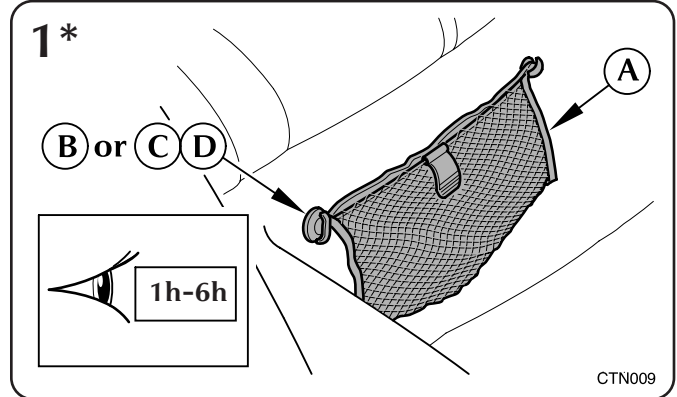

Notes: Note: Hinweise: Nota: 注

- 2*. Recommended fitting positions. Trunk, X-TYPE only.
- 2*. Positions de montage recommandées. Coffre, uniquement X-Type.
- 2*. Empfohlene Einbauposition. Kofferraum; nur X-TYPE.
- 2*. Posizioni di montaggio suggerite. Bagagliaio, solo X-TYPE.
- 2*. Posición de montaje recomendada. Maletero, sólo X-TYPE.
- 2*. 固定位置の例。トランク、X-タイプのみ。

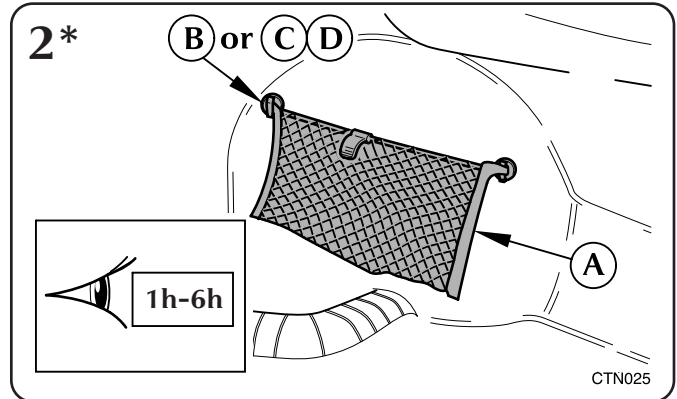

Notes: Hinweise: Note: Nota: 注

- 3*. Recommended fitting positions. Trunk for X-TYPE.
- 3*. Positions recommandées. Coffre à bagages de la X-TYPE.
- 3*. Empfohlene Einbauposition. Kofferraum bei X-TYPE Fahrzeugen.
- 3*. Posizioni di fissaggio consigliate. Bagagliaio per X-TYPE.
- 3*. Posiciones de montaje recomendadas. Maletero para los vehículos de la serie X-TYPE.
- 3*. 推奨される取り付け位置。X-TYPE および。

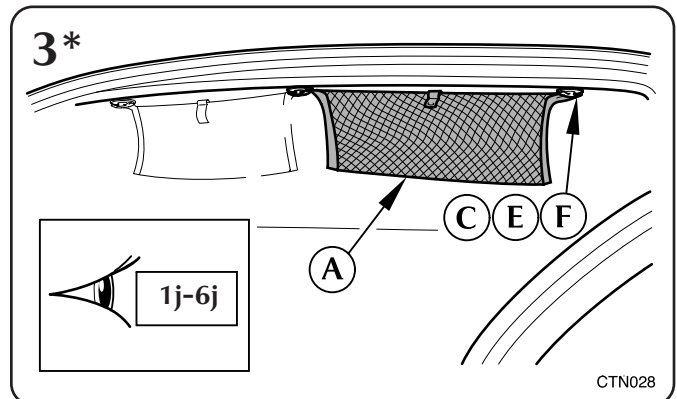



FITTING INSTRUCTIONS, INSTRUCTIONS DE MONTAGE,
EINBAUANLEITUNG, ISTRUZIONI DI MONTAGGIO,
INSTRUCCIONES DE MONTAJE, 取扱説明書

X-TYPE
(h)

Car Tidy Net, Filet de rangement, Gepäcknetz,
Retina portaoggetti, Red de almacenamiento,
車両用整頓ネット

1h

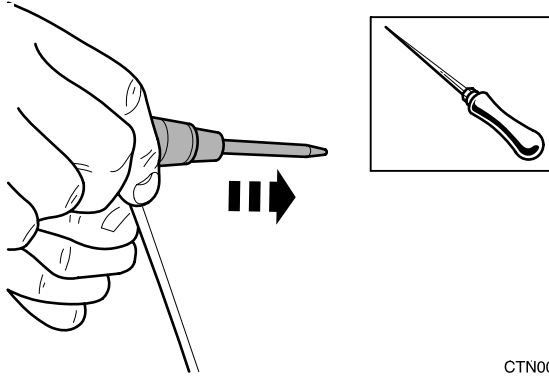

CTN002

2h

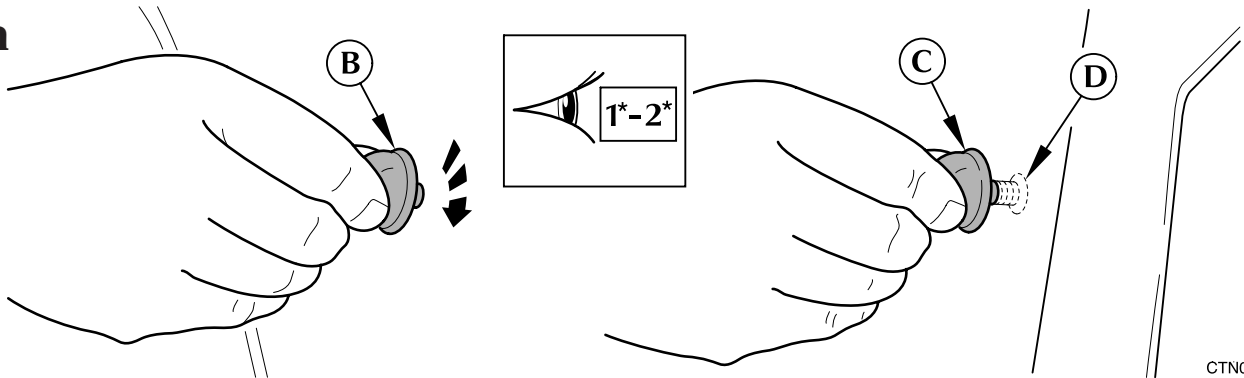

CTN003

3h

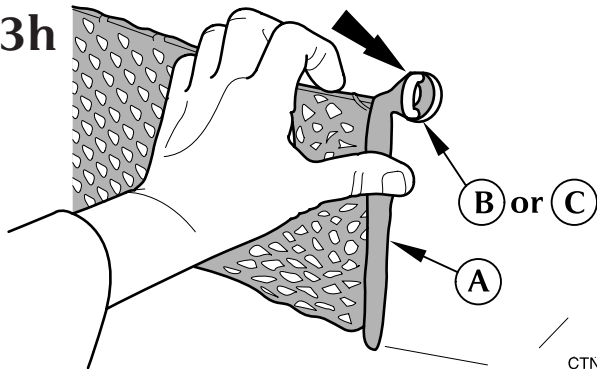

CTN004

4h

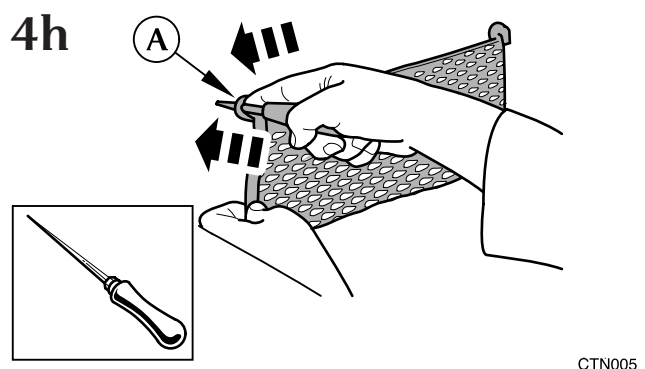

CTN005

5h

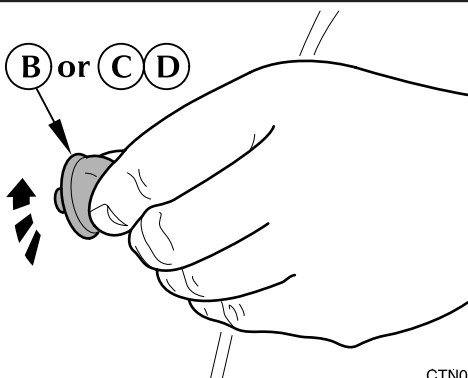

CTN006

6h

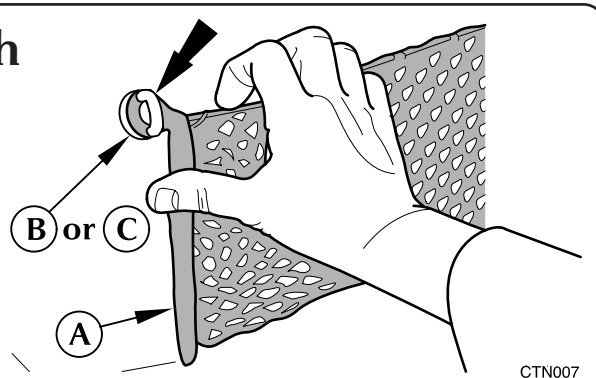

CTN007

MY 2001 →

Part No. C2A 1408

X-TYPE
(j)

**Car Tidy Net, Filet de rangement, Gepäcknetz,
 Retina portaoggetti, Red de almacenamiento,
 車両用整頓ネット**

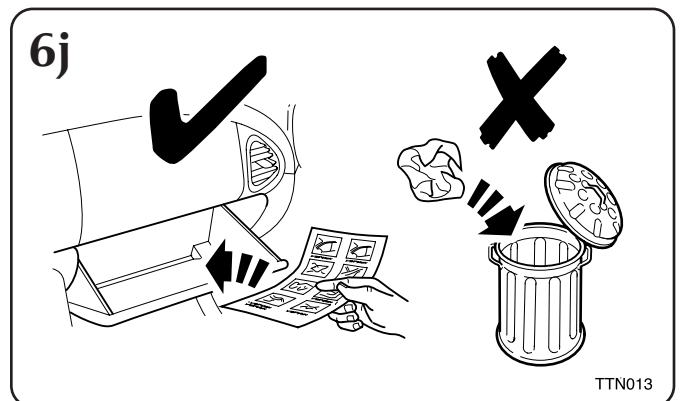
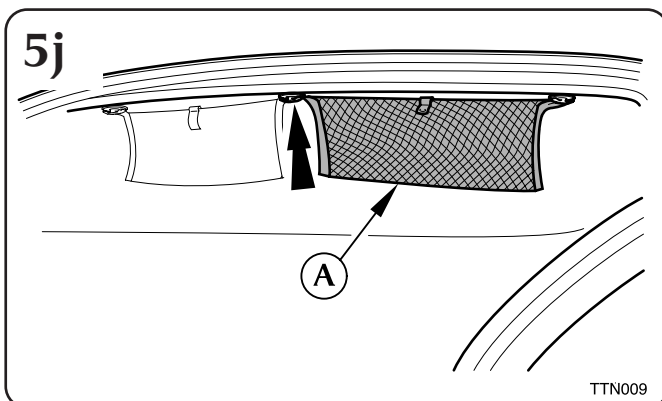
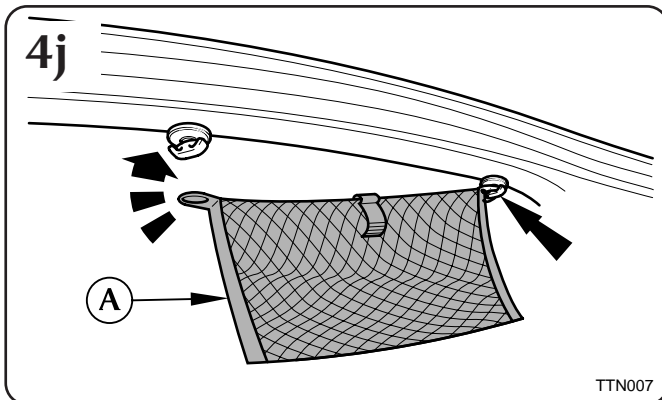
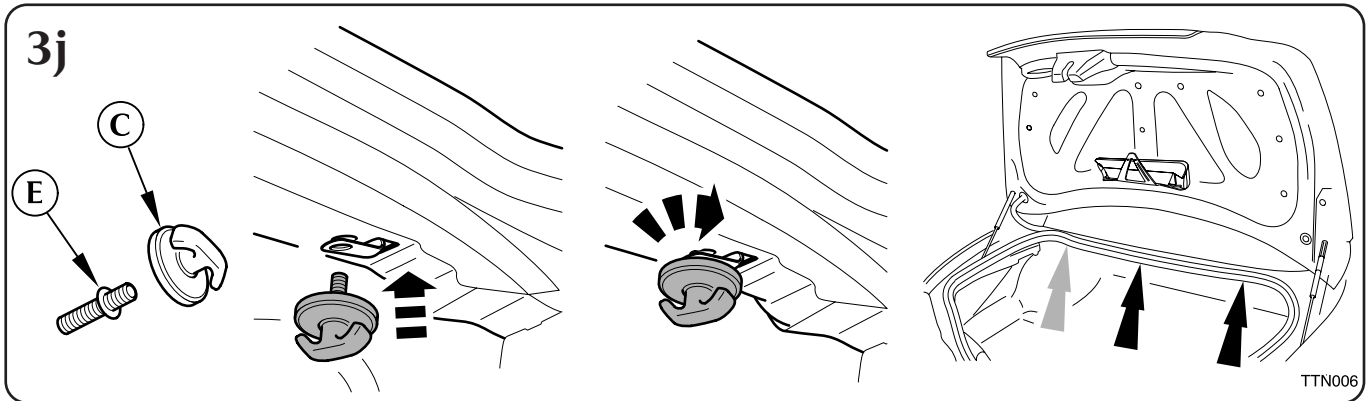
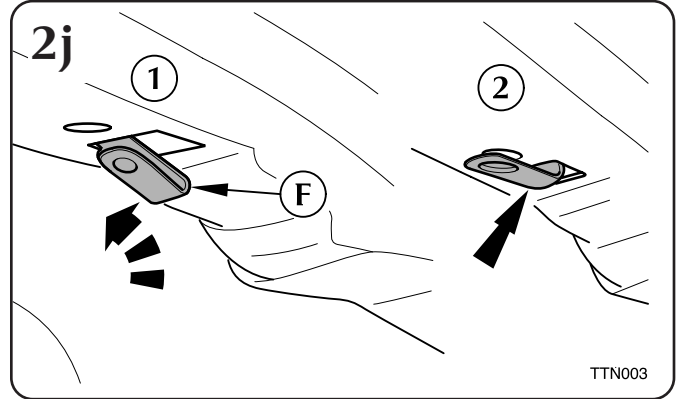
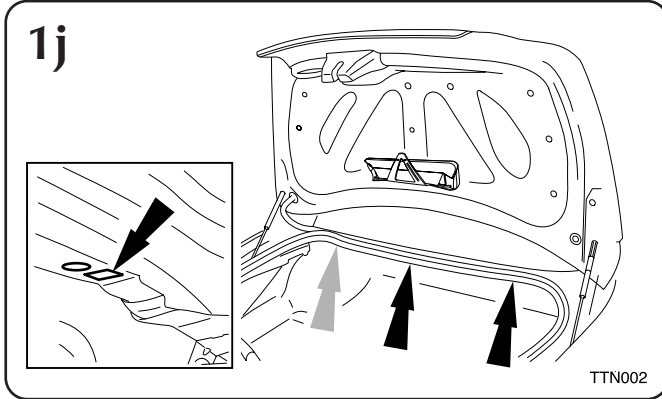



**FITTING INSTRUCTIONS, INSTRUCTIONS DE MONTAGE,
EINBAUANLEITUNG, ISTRUZIONI DI MONTAGGIO,
INSTRUCCIONES DE MONTAJE, 取扱説明書**

**The XJ, La XJ,
Der XJ, XJ
(k)**

**Car Tidy Net, Filet de rangement, Gepäcknetz,
Retina portaogetti, Red de almacenamiento,
車両用整頓ネット**

Notes: Hinweise: Note: Nota: 注

- 1*. Recommended fitting positions. RH & LH Rear seat heelboard.
- 1*. Positions de montage recommandées. Planche à talon banquette arrière côtés gauche et droit.
- 1*. Empfohlene Einbauposition. Rücksitz-Fersenblechabdeckung, rechts/links.
- 1*. Posizioni di montaggio suggerite. Vano piede sedili posteriori sinistro e destro.
- 1*. Posición de montaje recomendada. Espacio para los pies, asientos traseros derecho e izquierdo.
- 1*. 固定位置の例。RH及びLHリアシートヒールボード。

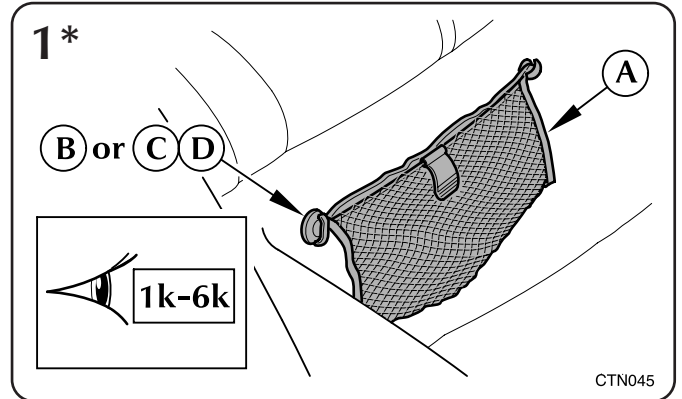

Notes: Hinweise: Note: Nota: 注

- 2*. Recommended fitting positions. Passenger side gearbox cover.
- 2*. Positions de montage recommandées. Housse de boîte de vitesse côté passager.
- 2*. Empfohlene Einbauposition. Getriebegehäuse, Beifahrerseite.
- 2*. Posizioni di montaggio suggerite. Coperchio cambio velocità lato passeggero.
- 2*. Posición de montaje recomendada. Cubierta de la caja de cambios, lado del pasajero.
- 2*. 固定位置の例。助手席側ギヤボックスカバー

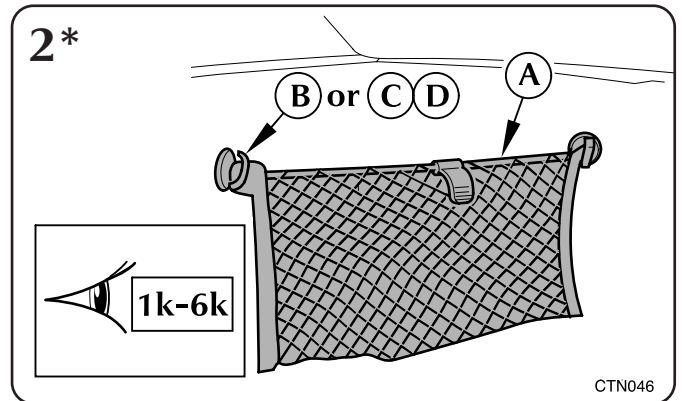

Notes: Hinweise: Note: Nota: 注

- 3*. Recommended fitting positions. Trunk for The XJ.
- 3*. Positions recommandées. Coffre à bagages de La XJ.
- 3*. Empfohlene Einbauposition. Kofferraum des neuen XJ.
- 3*. Posizioni di fissaggio consigliate. Bagagliaio per La XJ.
- 3*. Posiciones de montaje recomendadas. Maletero para los vehículos de La XJ.
- 3*. 推奨される取り付け位置。XJ のトランク。

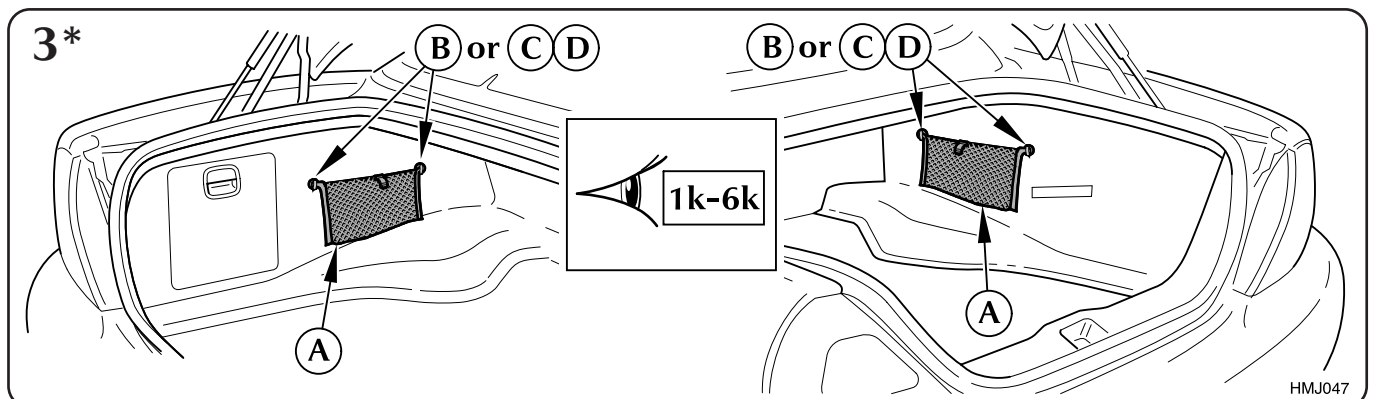

MY 2003 →

Part No. C2A 1408



FITTING INSTRUCTIONS, INSTRUCTIONS DE MONTAGE,
EINBAUANLEITUNG, ISTRUZIONI DI MONTAGGIO,
INSTRUCCIONES DE MONTAJE, 取扱説明書

The XJ, La XJ,
Der XJ, XJ
(k)

Car Tidy Net, Filet de rangement, Gepäcknetz,
Retina portaoggetti, Red de almacenamiento,
車両用整頓ネット

1k

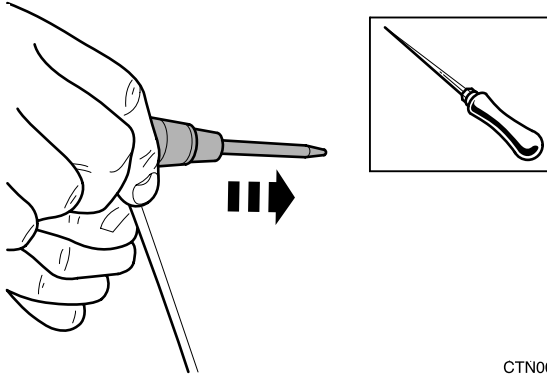

CTN002

2k

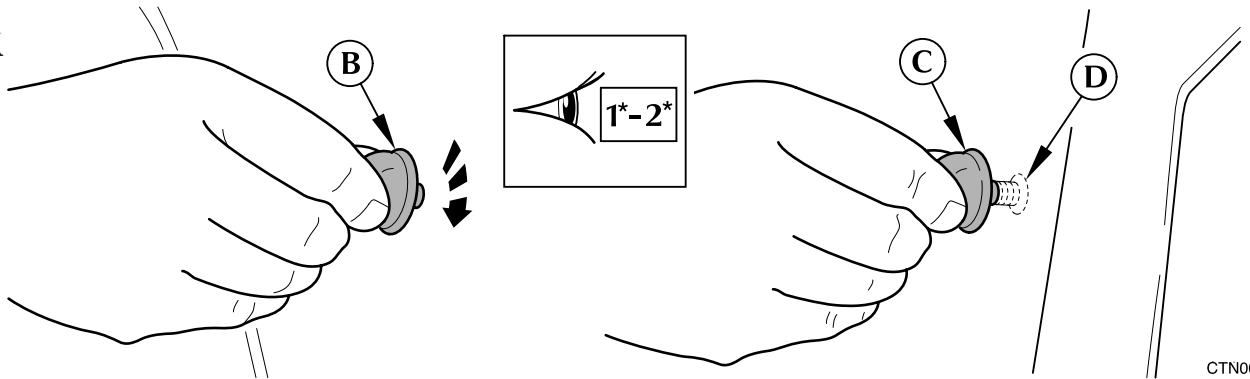

CTN003

3k

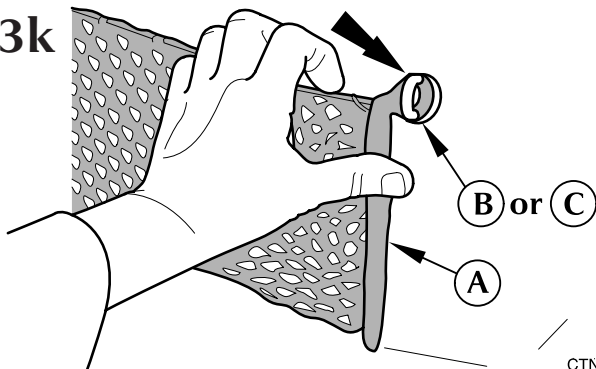

CTN004

4k

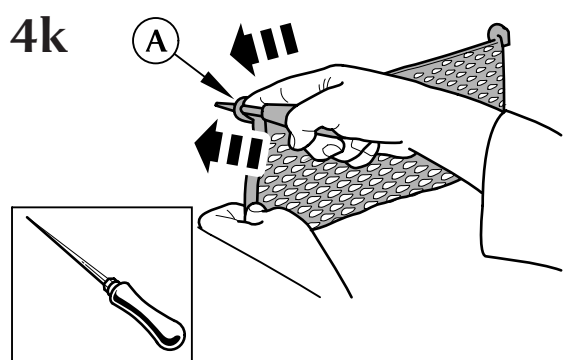

CTN005

5k

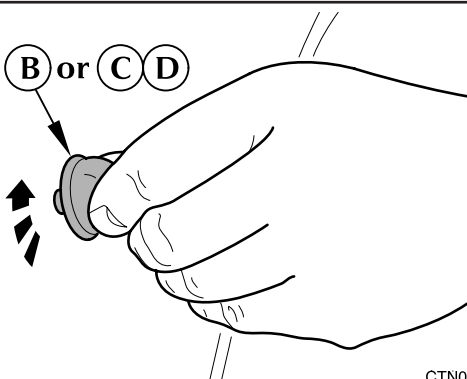

CTN006

6k

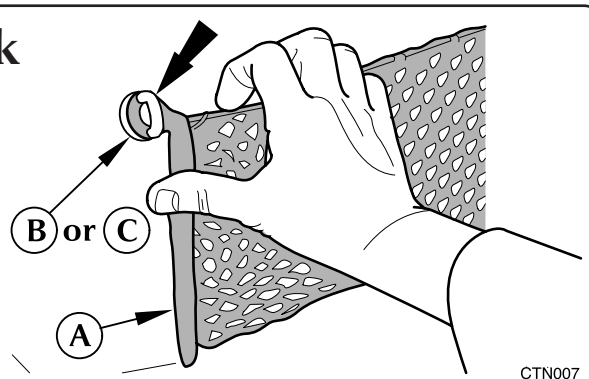

CTN007

MY 2003 →

Part No. C2A 1408