

### Variable Valve Timing

The variable valve timing system improves low and high speed engine performance, engine idle quality and exhaust emission. It is a two position system that operates on the intake camshafts only. There are 30° of crankshaft movement between the retarded and advanced positions. Engine oil pressure operates the system under the control of the ECM. For each intake camshaft there is a valve timing unit, a bush carrier assembly and a valve timing solenoid.

#### Valve Timing Unit

The valve timing unit turns the intake camshaft in relation to the primary chain to advance and retard the timing. The unit consists of a body and sprocket assembly separated from an inner sleeve by a ring piston and two ring gears. A bolt secures the inner sleeve to the camshaft. The ring gears engage in opposing helical splines on the body and sprocket assembly and on the inner sleeve. The ring gears transmit the drive from the body

and sprocket assembly to the inner sleeve and, when moved axially, turn the inner sleeve in relation to the body and sprocket assembly. Engine oil pressure (controlled by the valve timing solenoid) moves the ring gears and piston to turn the inner sleeve in the advanced timing direction. A return spring moves the ring gears and piston to turn the inner sleeve in the retarded timing direction. Additional springs absorb backlash to reduce noise and wear. The springs between the ring gears absorb rotational backlash. The spring between the inner sleeve and the end of the body and sprocket assembly absorbs axial backlash.

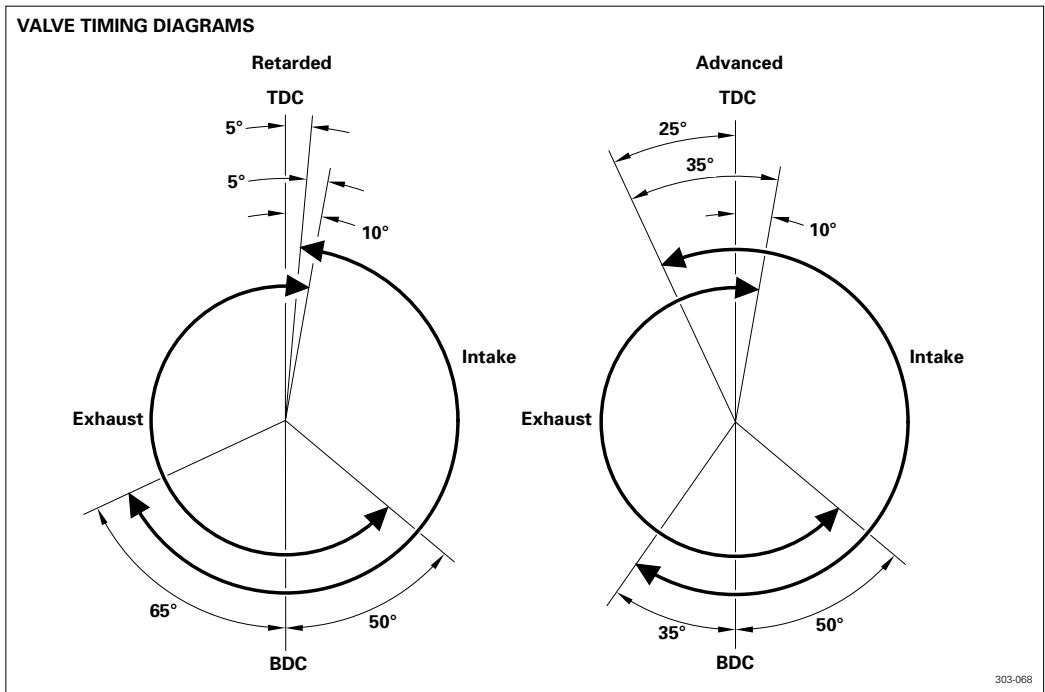

**VALVE TIMING UNIT**

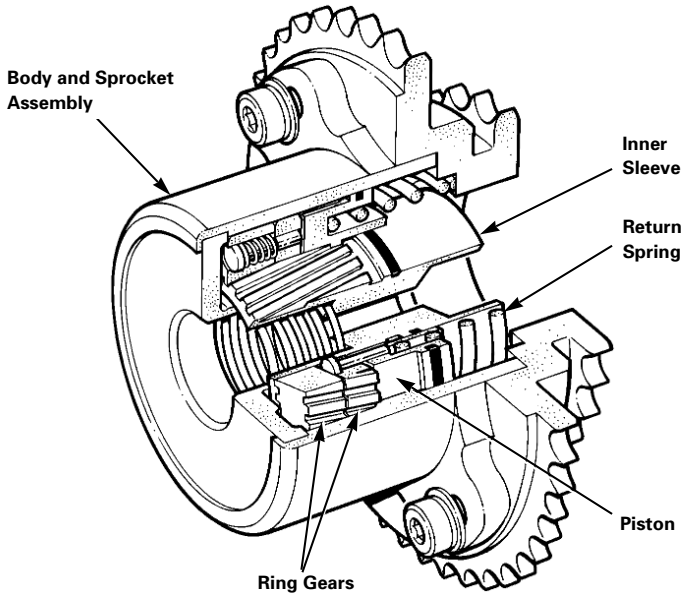

303-002

**Bush Carrier**

The bush carrier contains oil passages that link the engine oil supply to the valve timing unit. A lug on the bush carrier locates in the central bore of the valve timing unit. Two hollow dowels at the bush carrier to cylinder block interface ensure the lug is accurately located. A scarf-jointed fibre ring seals the joint between the lug and the valve timing unit. An integral shuttle valve, biased by a coil spring, controls the flow of oil through the oil passages.

**BUSH CARRIERS**

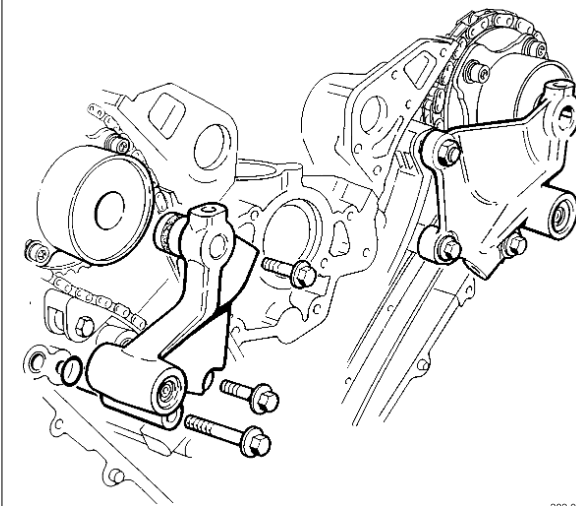

303-003

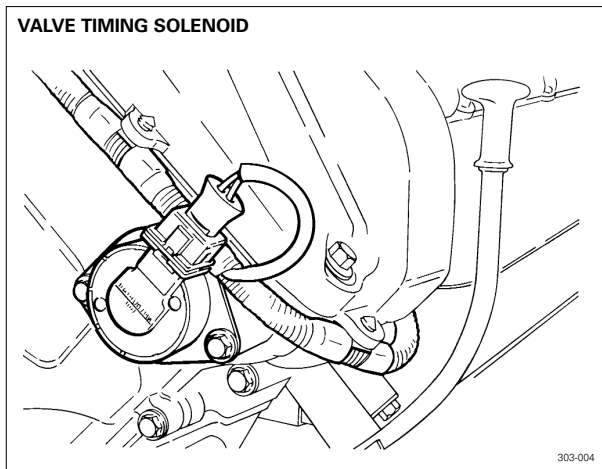

**Valve Timing Solenoid**

The valve timing solenoid controls the position of the shuttle valve in the bush carrier. A plunger on the solenoid extends when the solenoid is energised and retracts when the solenoid is de-energised.

**Operation**

When the valve timing solenoids are de-energised, the coil springs in the bush carriers position the shuttle valves to connect the valve timing units to drain. In the valve timing units, the return springs hold the ring pistons and gears in the retarded position.

When the valve timing solenoids are energised by the ECM, the solenoid plungers position the shuttle valves to direct engine oil to the valve timing units. In the valve timing units, the oil pressure overcomes the force of the return springs and moves the gears and ring pistons to the advanced position.

System response times are 1.0 second maximum for advancing and 0.7 second maximum for retarding.

While the valve timing is in the retarded mode, the ECM produces a periodic lubrication pulse.

