

6.0 Litre V12 / LM Engine Management System

Contents

6.0 Litre V12 / LM Engine Management System Overview	3 – 4
Crankcase Breather System	5
Fuel Injection: Overview	6 – 7
Fuel Delivery	8 – 11
Fuel Injection	12 – 17
Fuel Injection Components	18 – 21
Ignition: Overview	22 – 23
Ignition Timing Control	24 – 25
Ignition Components	26 – 28

6.0 Litre V12 / LM Engine Management System

6.0 Litre V12 / LM Engine Management System Overview

The 6.0 litre V12 Lucas / Marelli (V12 / LM) Engine Management System is the same for both the XJS and the XJ12 Sedan. This system employs a combination Lucas / Marelli fuel injection / ignition system that incorporates revisions to include new and expanded functions over the previous 1992 model year 5.3 litre V12 system. In addition to revised ECM functions, sub-systems that are not ECM controlled have been revised.

6.0 LITRE V12 ENGINE INSTALLATION: XJ12 SEDAN

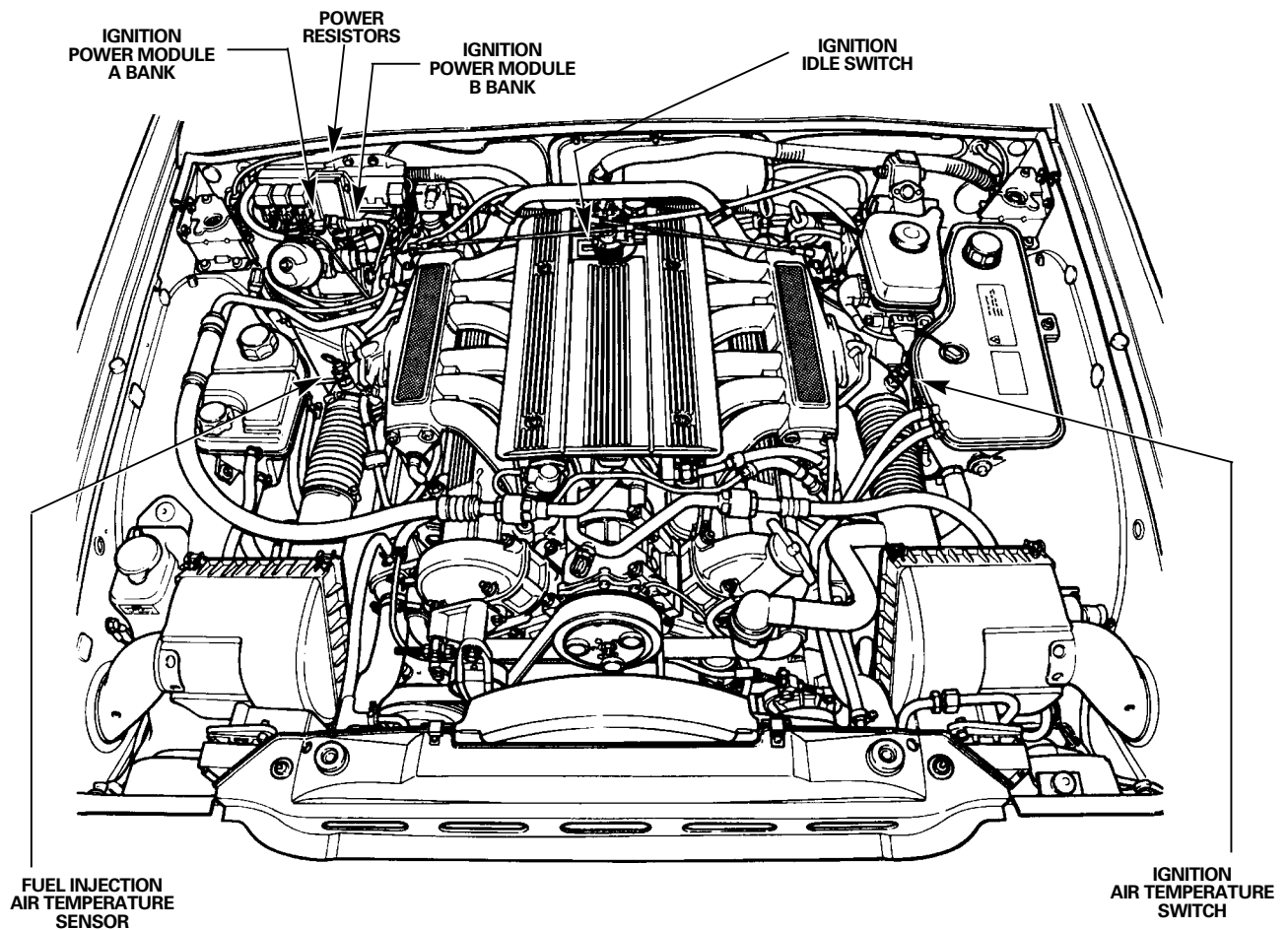

T850/1.01

6.0 Litre V12 / LM Engine Management System

6.0 Litre V12 / LM Engine Management System Overview (continued)

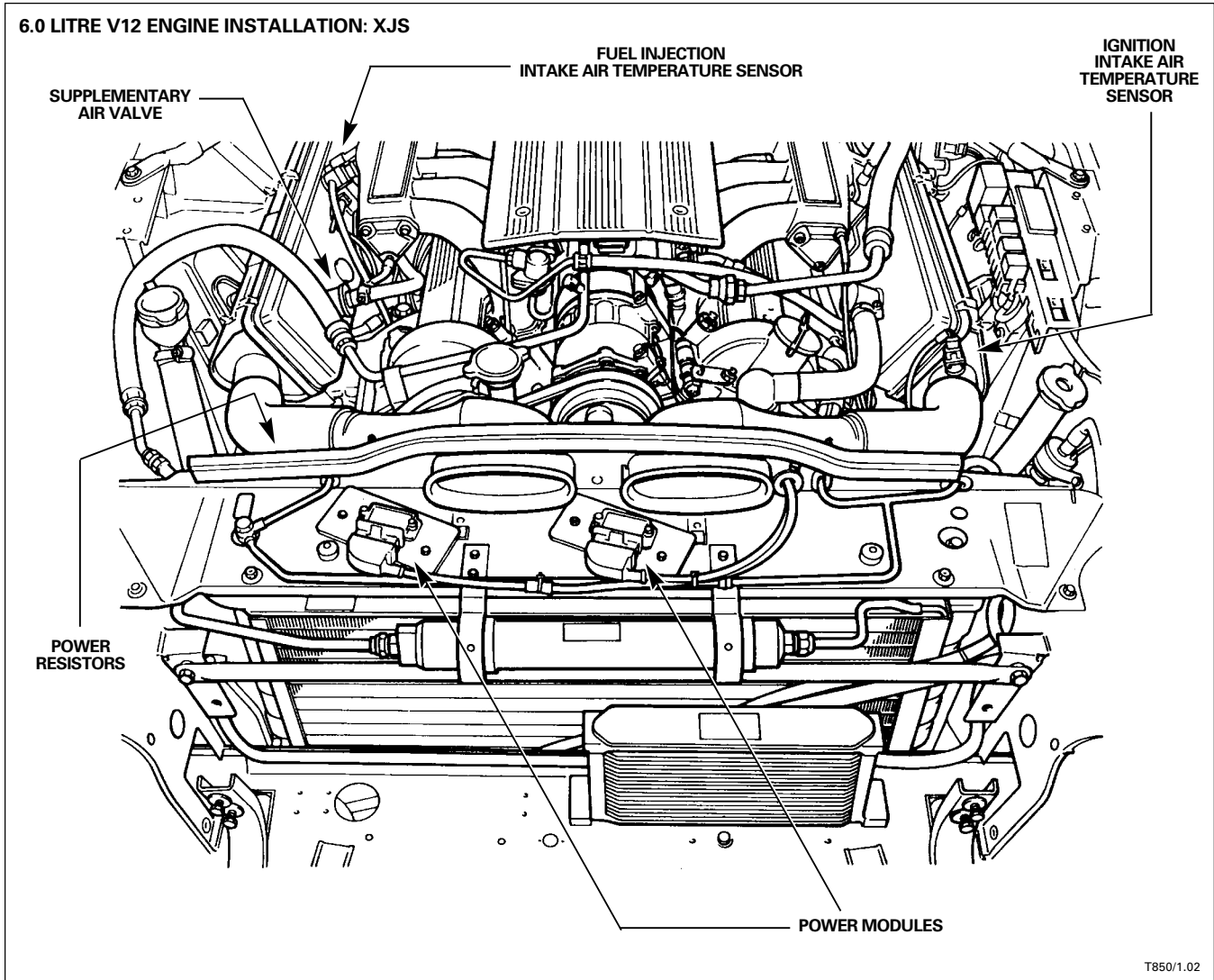

6.0 Litre V12 / LM Engine Management System

Crankcase Breather System

Part-load engine breather system

The part-load engine breather system consists of an air / oil separator chamber, integral with the jack shaft cover plate. The system connects to the intake manifolds down stream of the throttle housings.

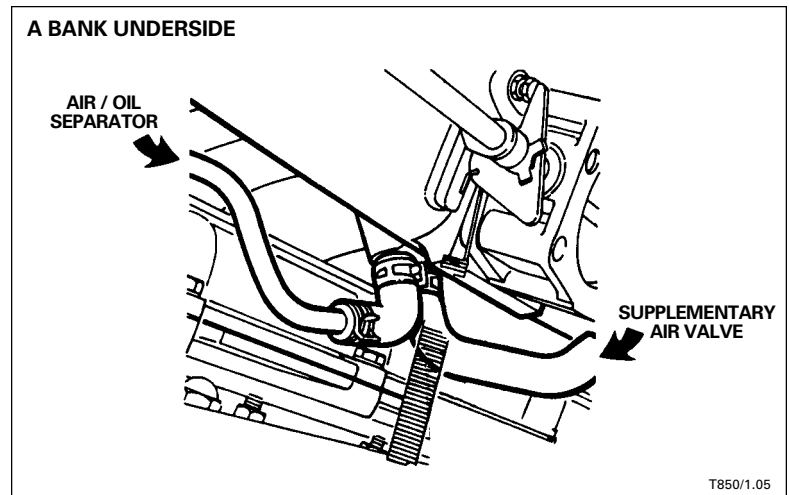
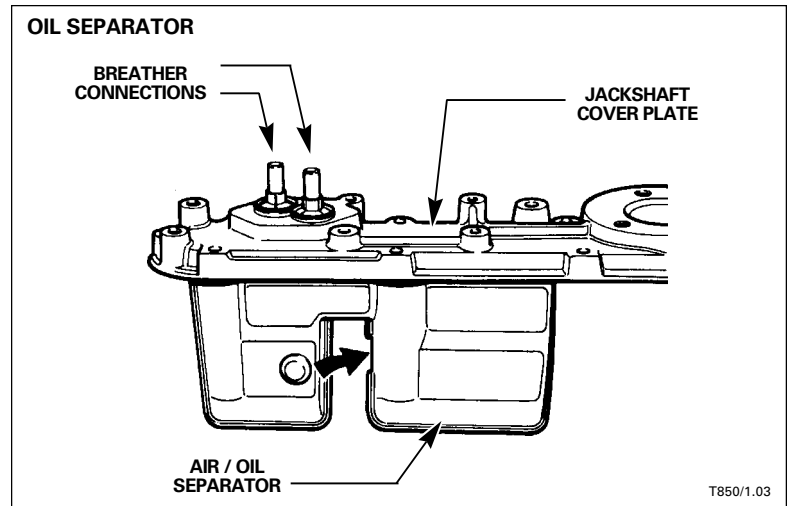
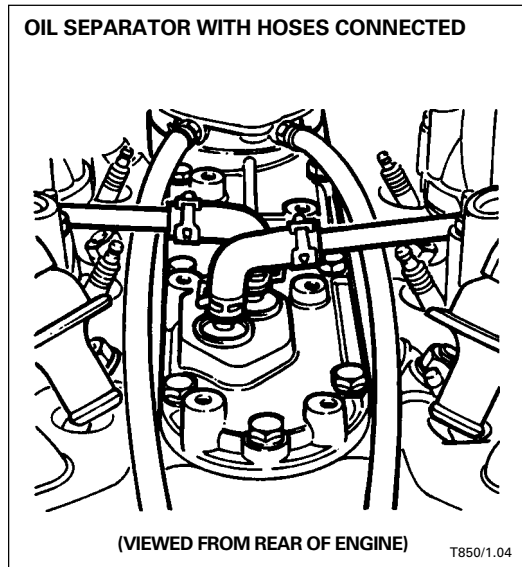

Full-load engine breather

The full load breather is connected from the B bank timing cover to the B bank air cleaner housing.

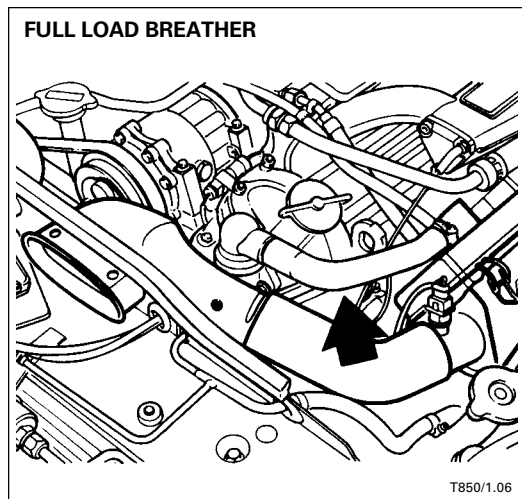

6.0 Litre V12 / LM Engine Management System

Fuel Injection: Overview

The fuel injection system maintains optimum fuel flow control over the entire engine operating range by precisely metering the fuel into each cylinder. The main parameters for determining fuel flow requirements are engine load and speed. The ECM senses engine load from intake manifold absolute pressure and engine speed from the ignition pulses.

The ECM incorporates a manifold pressure sensor (transducer) and has a memory with stored fuel-flow strategy for various combinations of engine load and speed. The ECM receives inputs from sensors, switches and the ignition system that are applied to its memory to determine the required fuel flow.

The 36CU ECM incorporates new and expanded function over the previous 26CU ECM. The complete range of fuel injection ECM functions is as follows:

- ECM self-test
- Fuel delivery (fuel pumps A and B)
- Fuel injection
- Cold start
- Warm-up
- Exhaust oxygen content feedback
- Fuel cutoff during engine overrun
- Evaporative canister purge control
- Adaptive idle fueling trim
- Air injection control
- Hot start system timing
- Fuel level sensing
- Fuel fail output to transmission control module
- Fuel monitoring (trip computer)
- On Board Diagnostics (OBD) with "Limp home" capability
- Serial Communications (ISO)

NOTE: The sensors and switches are unique to the fuel injection system and are not used or shared by the digital ignition system.

6.0 Litre V12 / LM Engine Management System

6.0 LITRE ENGINE MANAGEMENT SYSTEM: XJ12 SEDAN

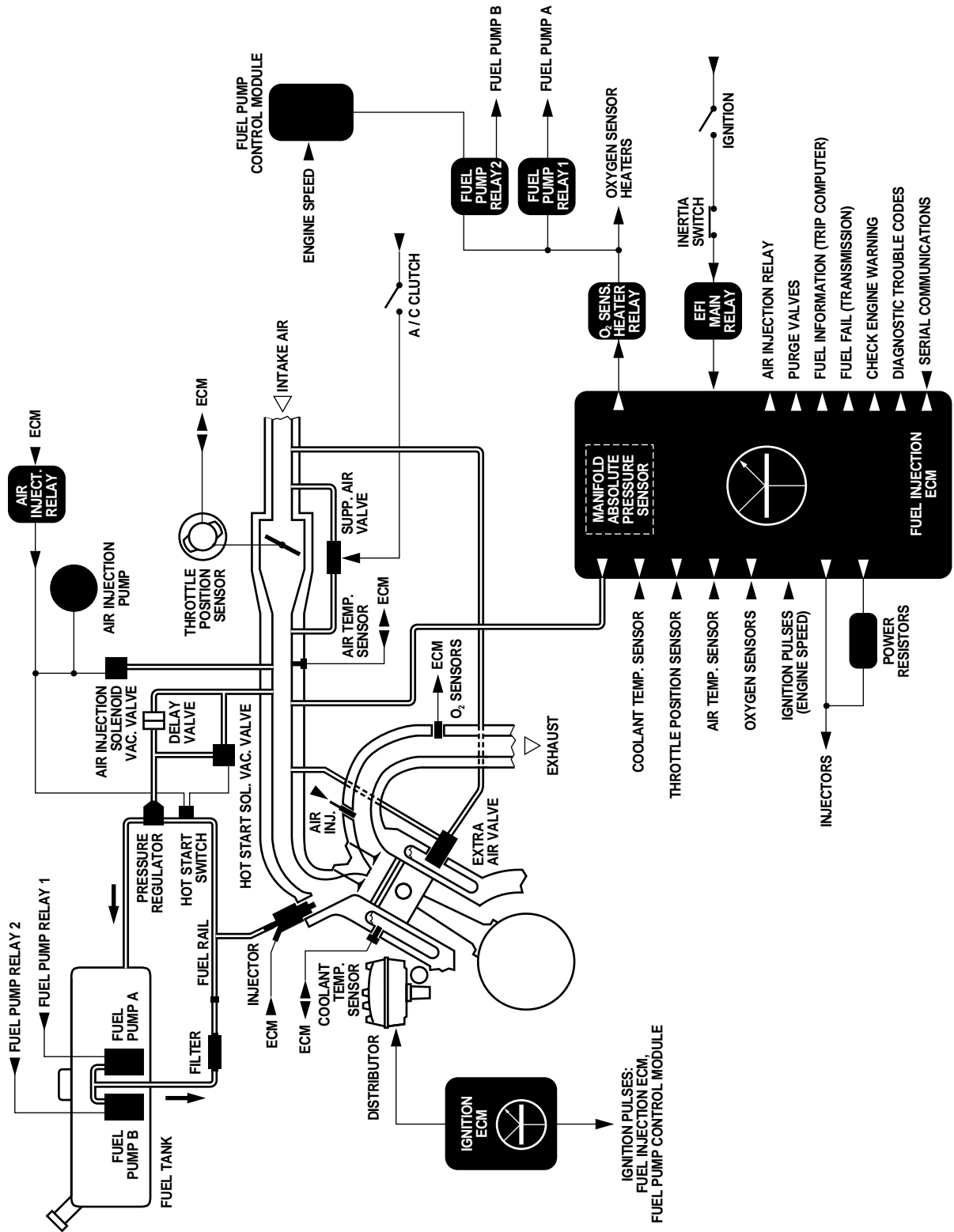

IGNITION PULSES:
FUEL INJECTION ECM,
FUEL PUMP CONTROL MODULE

6.0 Litre V12 / LM Engine Management System

Fuel Delivery

In order to meet the fuel requirements of the 6.0 litre engine, two fuel pump modules are used. The modules are identical but operate independently with staged control. One pump runs continuously when the engine is running, the other is activated when the engine speed exceeds 2840 rpm. Each pump is activated by a separate relay.

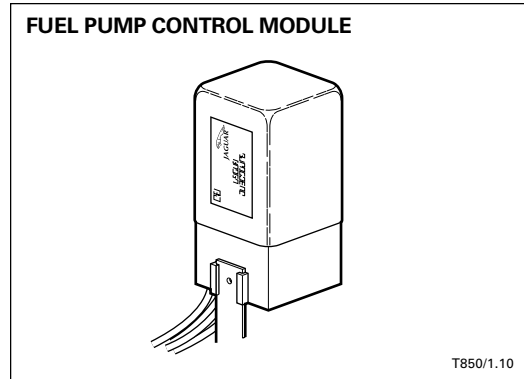

The fuel pump control module, located on the trunk right side, receives an engine speed input from the Ignition ECM and switches the relay 2 coil ground as follows. When the engine speed reaches 2840 rpm, the ground is completed; as the engine speed decreases, the ground is interrupted at 2000 rpm. Switching of fuel pump B requires just 1/4 of a second, ensuring instant response for additional fuel delivery.

XJ12 Sedan

The two fuel pump relays are switched by the Fuel Injection ECM via the oxygen sensor heaters relay; however, the coil circuit of relay 2 is completed to ground via the fuel pump control module.

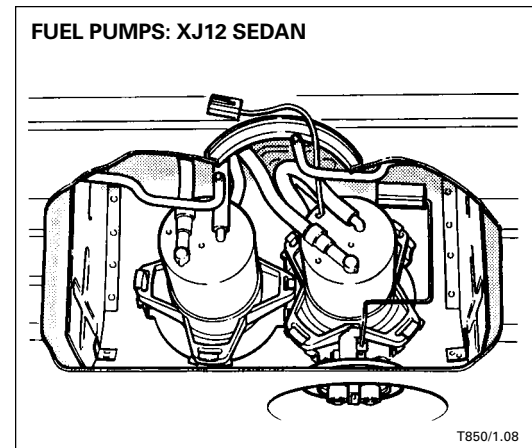
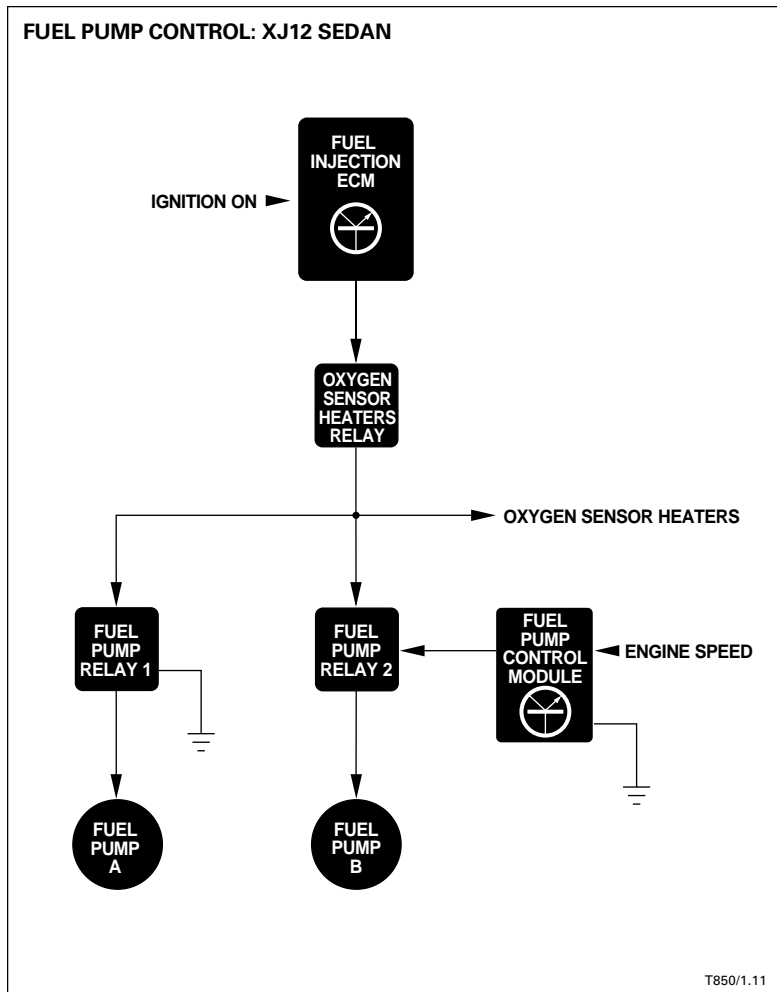

6.0 Litre V12 / LM Engine Management System

XJS

Fuel pump relay 1 is switched by the Fuel Injection ECM. Fuel pump relay 2 is switched by the fuel pump control module.

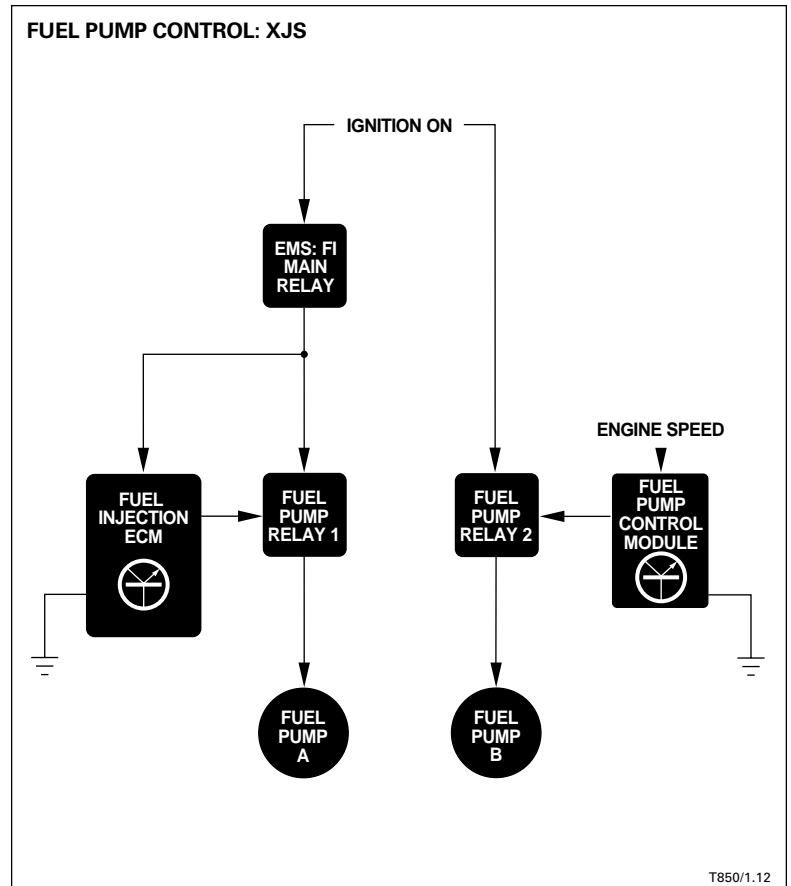
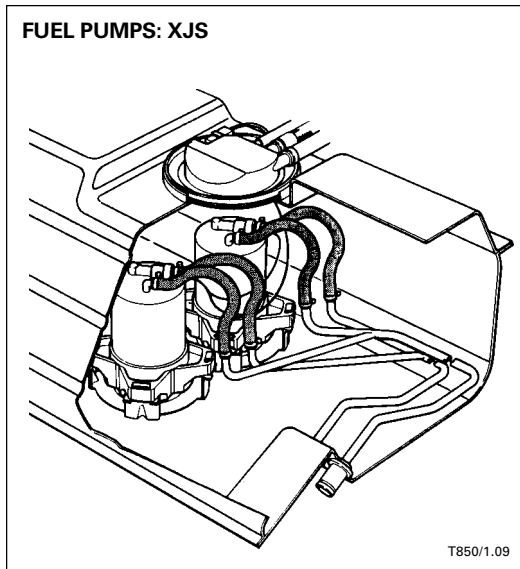

6.0 Litre V12 / LM Engine Management System

Fuel Delivery (continued)

Fuel pressure regulator

The fuel pressure regulator maintains the fuel rail pressure at 44 psi (3 bar).

Evaporative emission control

The evaporative emission control system uses the same canister and vacuum / pressure relief valve as the 4.0 liter XJS and the Sedan Range. Two purge control valves, one for each cylinder bank, are located at the charcoal canister. The purge valves are controlled by the fuel injection ECM. The ECM opens the valves simultaneously, according to an engine load and speed strategy, allowing purge flow to both intake manifolds. Purge flow is enabled at idle after adaptive idle fueling is completed. The charcoal canister is located at the front of the left front wheel arch.

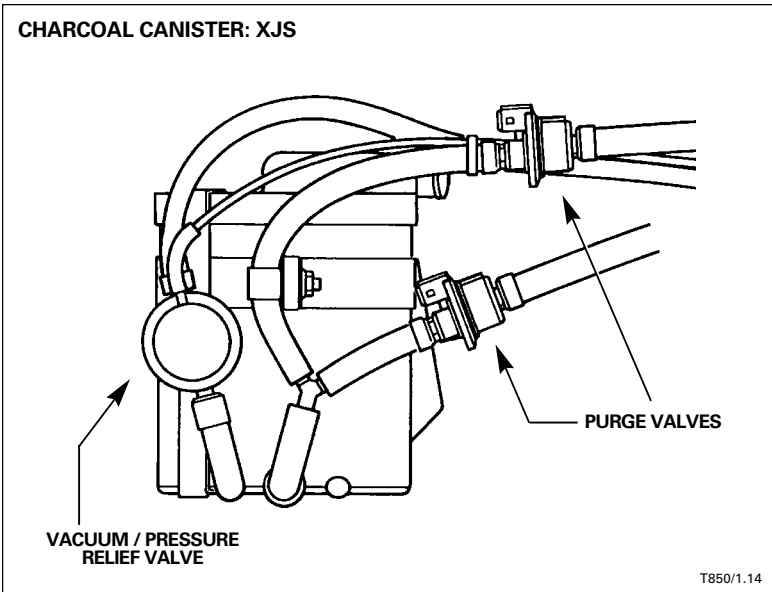
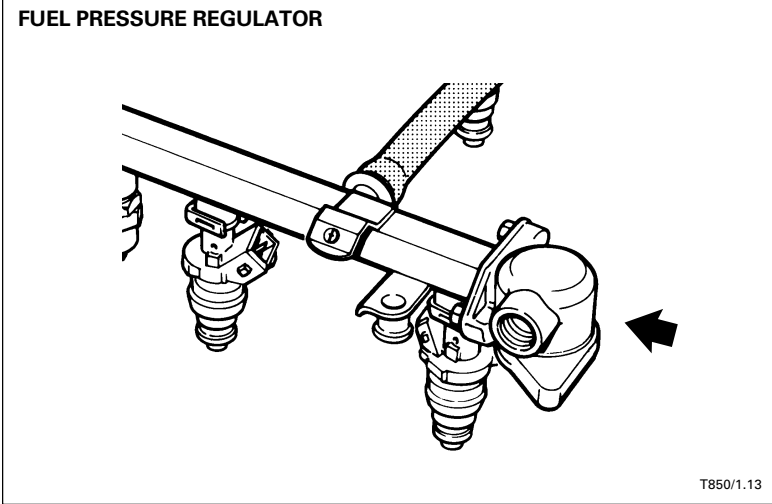

6.0 Litre V12 / LM Engine Management System

FUEL DELIVERY AND EVAPORATIVE EMISSION CONTROL SYSTEM

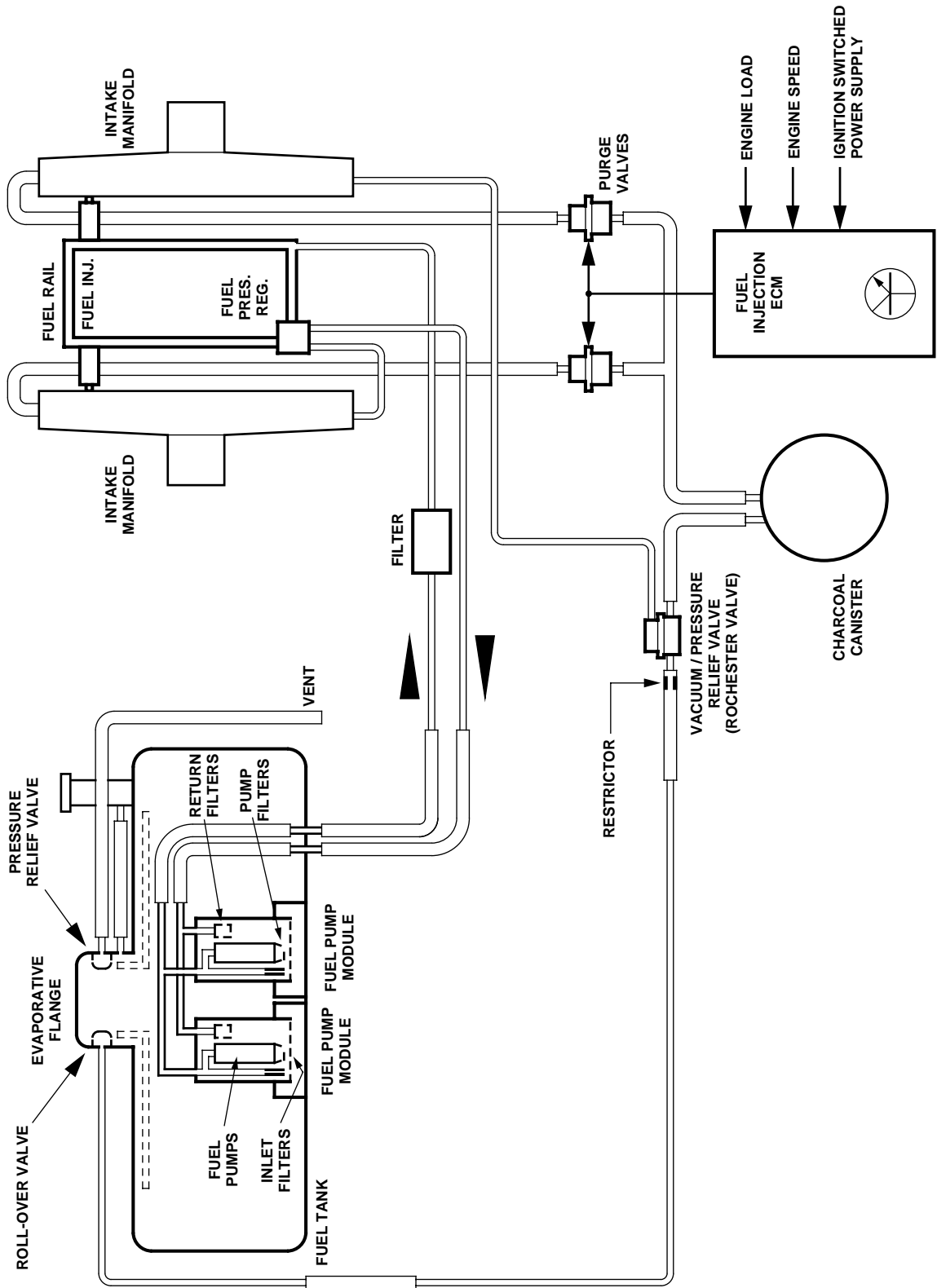

T850/1.15

6.0 Litre V12 / LM Engine Management System

Fuel Injection

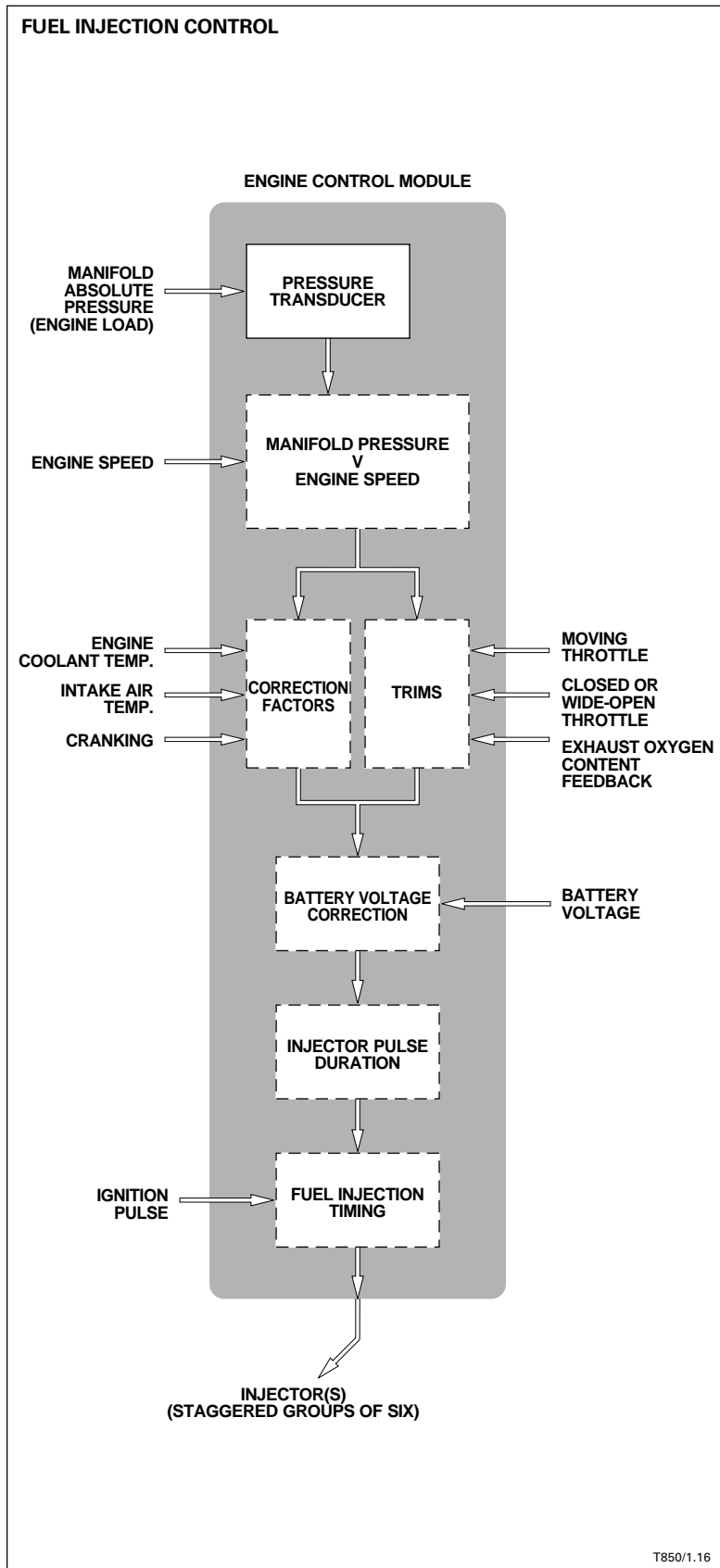

Fuel metering control

Fuel metering is obtained by controlling the injector pulse duration (on-time) during each engine cycle (two crankshaft rotations). The pulse duration is varied by the engine control module (ECM) according to several sensor inputs. The sensed control inputs form two groups — primary and secondary. Primary control inputs are intake manifold absolute pressure (MAP) and engine speed; secondary control inputs consist of engine coolant temperature, intake air temperature, throttle movement and position, exhaust oxygen content, cranking signal and battery voltage. The injectors are triggered via the power resistors, in staggered groups of six. Except during starting and sudden throttle opening, injector pulses occur every third ignition pulse (once per engine revolution).

Primary control

Fuel metering is controlled primarily as a function of intake manifold absolute pressure (MAP) and engine speed. Manifold pressure is sensed by a pressure transducer located in the engine control module and connected to the A bank manifold by a vacuum line. Engine speed is sensed from an ignition ECM output.

Fueling strategies are held in memory (EPROM) in the ECM and form a manifold pressure v engine speed matrix. Injector pulse duration is then calculated according to secondary correction factors and trims. The resulting injector pulse duration is further modified to account for battery voltage.

Injection timing depends on the crankshaft position and the ECM internal state at start-up. The ECM internal state is determined from the crankshaft position when the engine was last stopped and the ECM state when the ignition was turned off.

Secondary control

Secondary fueling enrichment is provided for engine starting, warm-up and throttle response at all temperatures within the engine's operating range.

Coolant temperature The coolant temperature sensor provides an electrical input to the ECM. During engine starting and warm-up, enrichment is provided by increasing the injector pulse duration when coolant temperature is below normal operating temperature. Enrichment is reduced with increasing engine speed and load.

Engine starting At engine cranking speeds, the ECM increases the number of injector pulses to three per engine revolution. It also increases the injector pulse duration in relation to coolant temperature sensor input. As engine speed increases, cranking enrichment is reduced to transition to the warm-up phase.

After start enrichment After engine start-up, the ECM increases the injector pulse duration above the normal running requirement and then decreases the pulse duration as a function of elapsed time after engine start.

Throttle movement and position The throttle position sensor provides electrical signals to the ECM for opened and closed throttle operation as well as throttle movement during acceleration and deceleration. In order to ensure good response when rapid throttle opening occurs, the ECM triggers an extra injector pulse to all injectors simultaneously. The duration of the extra pulse is dependent on coolant temperature.

Intake air temperature Fuel metering is adjusted to vary approximately with the density of the engine intake air. Intake air density is sensed by measuring the air temperature at the right air intakes.

Full load Full load fuel metering varies with throttle position and engine speed. Under full load conditions, exhaust oxygen sensor closed loop control is disabled.

Air / fuel ratio (closed loop control) In order to achieve optimum performance from the exhaust three-way catalyst system, the exhaust oxygen content is monitored and controlled by trimming the fuel metering. Two oxygen sensors are used: one in each exhaust down-pipe, after the primary catalyst. Closed loop control is disabled under these conditions:

- during engine warm-up when the air injection is operating
- during full load operation
- during deceleration fuel cutoff (engine overrun).

Battery voltage The time necessary for full injector open and close to occur varies with battery voltage. For example, with low battery voltage, the time necessary for full injector open to occur is long; therefore, less fuel is delivered for a given pulse duration. The opposite is true for high battery voltage. The ECM corrects the injector pulse duration to achieve the fuel delivery that would be obtained at a nominal reference voltage.

6.0 Litre V12 / LM Engine Management System

Fuel Injection (continued)

Adaptive idle fueling trim

In order to ensure optimum performance throughout the life of the vehicle, the fuel injection ECM software contains an adaptive idle fueling function that automatically trims the fuel injector idle pulse duration strategy. The total available trim to the nominal injector pulse duration is $\pm 20\%$. This function eliminates the manual adjustment of idle trim. Adaptive fueling is performed by the ECM software only when there are no diagnostic trouble codes (DTCs) present, and the listed preconditions are met.

Adaptive idle fueling preconditions:

- Throttle closed
- Engine speed below 900 rpm
- Air injection disabled after engine start
- Closed loop fueling control enabled

If there are no DTCs present and the preconditions are met, the ECM cancels purge flow and adapts the idle fueling. Between fueling adaptations, there is a delay of approximately eight minutes during which the preconditions must be met. If the preconditions are interrupted, the delay will be lengthened.

Air injection

The 6.0 litre air injection system is similar to the AJ6 4.0 litre air injection system. An air injection pump with an electric clutch, and a vacuum operated air cutoff valve are controlled by the fuel injection ECM. Air injection is enabled after all engine starts. The ECM uses a strategy comprised of a number of injector pulses versus engine coolant temperature for air injection switch-off. Air injection is enabled following all hot starts and always operates below 115°F (47°C) engine coolant temperature. The air shut-off valve is operated by vacuum applied by the solenoid vacuum valve when signaled from the ECM.

NOTE: The XJS air injection pump is operationally the same as the XJ12 pump, however, it is manufactured by a different supplier.

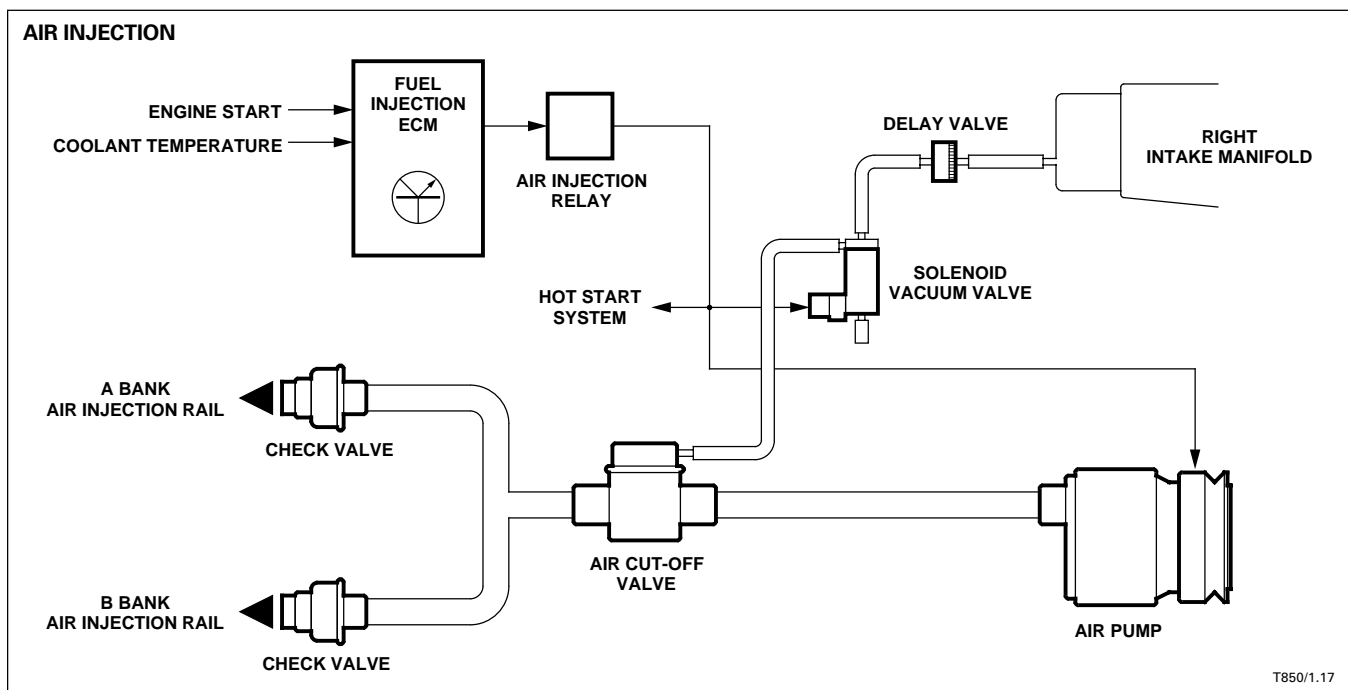

6.0 Litre V12 / LM Engine Management System

Hot start system

The hot start system remains the same as the previous 5.3 liter system with the exception of the timing control. The function of the previous 45-second timer is replaced by fuel injection ECM control. When air injection is enabled, current is applied to the hot start switch. If the fuel rail temperature is 158°F (70°C) or above, the switch closes and activates the solenoid vacuum valve. The solenoid vacuum valve is mounted on the front of the right throttle body. The activated valve closes and directs vacuum to the fuel pressure regulator through the delay valve. The momentary vacuum delay increases fuel pressure to purge the fuel rail.

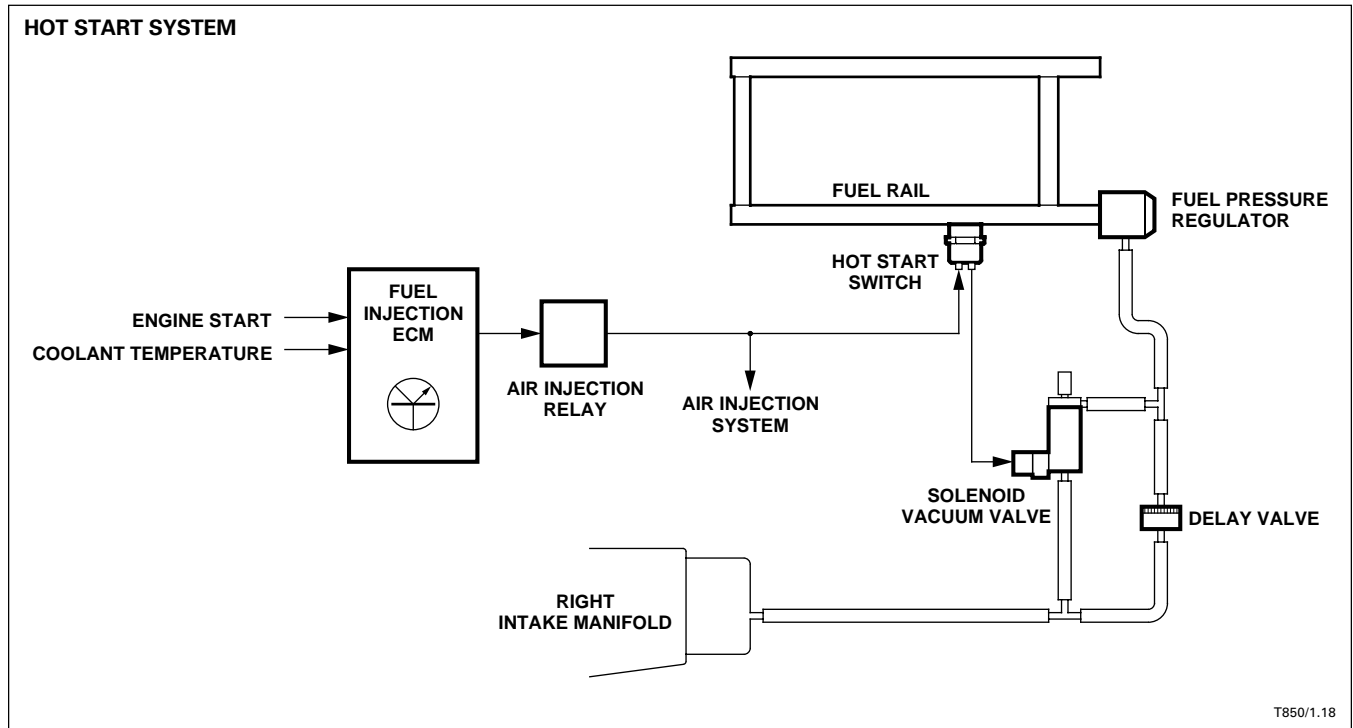

Idle speed control

Base idle speed control is maintained solely by the adjustable idle air bleed at the extra air valve.

Idle speed stabilization Idle speed stabilization is enabled when the air conditioning compressor is operating. The supplementary air valve is activated with the compressor clutch to allow throttle-valve-bypass air flow to the right intake manifold. The valve operates in all gear selector positions.

6.0 Litre V12 / LM Engine Management System

Fuel Injection (continued)

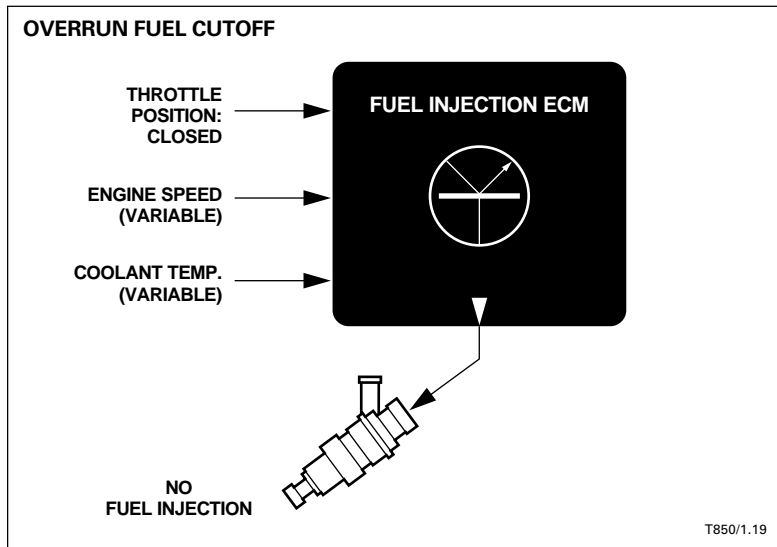

Fuel Cutoff

Overrun fuel cutoff To improve fuel economy and aid in controlling exhaust emissions, the ECM cuts off fuel injection during engine overrun conditions. The ECM determines overrun conditions from throttle position (throttle position sensor), engine speed (ignition pulses) and coolant temperature.

Coolant Temperature	Cutoff RPM	Reinstatement RPM
Up to -5°F (-15°C)	5000	4000
32°F (0°C)	3000	2000
50°F (10°C)	2000	1500
68°F (20°C)	1900	1400
86°F (30°C)	1900	1400
104°F (40°C)	1800	1300
149°F (65°C) and above	1500	1100

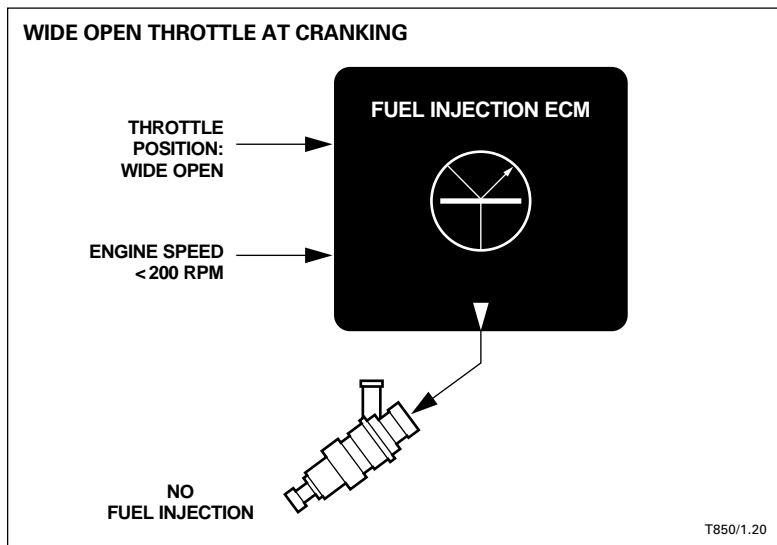

Wide Open Throttle during cranking When the ECM senses that the throttle is wide open (throttle position sensor) during cranking (<200 rpm, ignition pulse input), fuel injection is canceled to prevent the engine from flooding.

On-Board Diagnostics System (OBD)

The ECM includes a fault diagnosis facility that continuously monitors the operation of the engine management sensors and components. If a fault is detected, the OBD system will activate the CHECK ENGINE warning in the instrument pack and on the trip computer display. In addition, it will flag a diagnostic trouble code (DTC) in the ECM memory. The ECM can, at any time, be interrogated through the trip computer display by switching off the ignition then switching on the ignition. The CHECK ENGINE warning will display and the DTC will appear 5 seconds later. If two or more DTCs are flagged in memory, only the highest priority code will be displayed. The remaining codes will be displayed, in turn, as the faults are corrected and erased from memory.

NOTE: In order to prevent the erroneous flagging of codes, a fuel level input (voltage) to the fuel injection ECM is supplied. The ECM will not flag DTCs 13, 18, 19, 23, 34, 36, 44 and 45 when the fuel tank level falls below approximately 1 gallon.

6.0 Litre V12 / LM Engine Management System

Serial communications

Serial communications between the engine management system and JDS or PDU are available via the serial communications data link connector located in the trunk. Serial communication is used for engine setup, fault diagnosis and erasing diagnostic trouble codes.

Limp home mode

In order to allow vehicle operation if a malfunction occurs, "limp home" default strategies are incorporated as an ECM facility. The ECM will substitute a nominal value for missing inputs from various sensors and components.

Diagnostic trouble code summary

The available DTCs are listed in order of priority on the following table. Limp home mode is available as indicated. When multiple faults occur, only the highest priority code will be displayed.

DTC	Limp Home Mode	Input or Component checked
29		ECM Self-test
44	X	Oxygen sensor circuit — A bank
45	X	Oxygen sensor circuit — B bank
13	X	Manifold pressure transducer and sensing hose
34		Injector electrical circuits — A bank
36		Injector electrical circuits — B bank
14	X	Coolant temperature sensor circuit
17	X	Throttle position sensor circuit
18	X	Manifold pressure transducer / throttle position sensor circuit (high throttle voltage / low MAP)
19	X	Manifold pressure transducer / throttle position sensor circuit (low throttle voltage / high MAP)
23		Fuel metering at idle — banks A and B combined
49	X	Power resistors electrical circuits
11	X	Pressure transducer / throttle position sensor circuit
16	X	Intake air temperature sensor circuit
67		Air injection operation (oxygen sensor response)
77		Engine speed (loss of input from ignition ECM)

Clearing diagnostic trouble codes

All DTCs are held in the ECM memory until cleared using serial communication. If the vehicle battery is disconnected, the DTC(s) will be cleared.

6.0 Litre V12 / LM Engine Management System

36CU ENGINE CONTROL MODULE: FUEL INJECTION

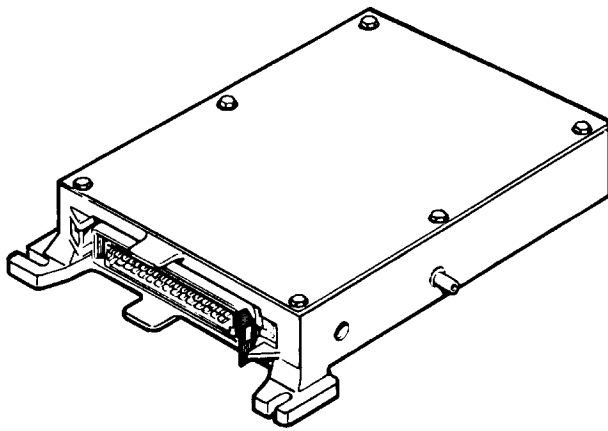

T850/1.21

Fuel Injection Components

Engine control module (ECM): Fuel Injection

Location Trunk, right front.

Description The 36CU ECM contains an integrated circuit for a dedicated fuel injection control chip and an analog / digital converter for the manifold pressure input. A manifold absolute pressure sensor (transducer) is built into the ECM. Fuel injection information is stored in ROM (read only memory), so that for a given combination of manifold pressure and engine speed, the memory assigns a number proportional to the required injector pulse duration. The ECM also contains facilities for OBD and serial communications.

Fuel injectors

Location Intake manifolds.

Description Each fuel injector contains a solenoid-operated needle valve, which is held against a seat by spring pressure. When energized, the coil moves the needle away from the seat, allowing pressurized fuel to flow through the tip.

FUEL INJECTOR

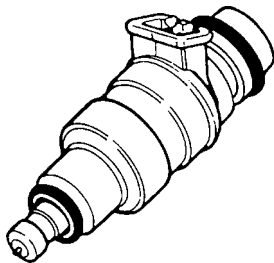

T850/1.22

Power resistors

Location Engine compartment: right bulkhead (XJ12); right front (XJS).

Description The power resistor pack contains four 6-ohm resistors. Each resistor is connected to a group of 3 injectors to limit the current during the "hold" portion of the injector pulse duration. Limiting the current protects the ECM.

POWER RESISTOR

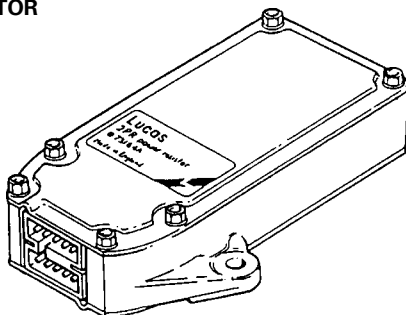

T850/1.23

Throttle position sensor

Location Under the throttle turntable.

Description The twin track throttle position sensor is mechanically connected to the throttle valve shaft and provides a reference voltage input to the ECM dependent on throttle position and rate of acceleration. The second track is used by the transmission control system.

THROTTLE POSITION SENSOR

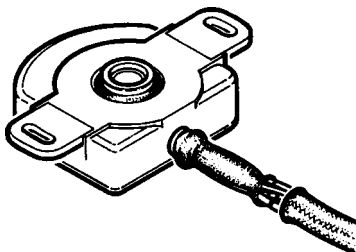

T850/1.24

6.0 Litre V12 / LM Engine Management System

Coolant temperature sensor

Location Left thermostat housing.

Description The coolant temperature sensor is a temperature-sensitive resistor. As the coolant temperature rises, the electrical resistance decreases providing a coolant temperature input to the ECM.

Coolant Temp.		Resistance (kilohms)	Voltage (±)
(°F)	(°C)		
14	-10	9.2	3.27
32	0	5.9	3.11
50	10	3.7	2.91
78	20	2.5	2.66
86	30	1.7	2.38
104	40	1.18	2.07
122	50	0.84	1.76
140	60	0.60	1.48
158	70	0.435	1.22
176	80	0.325	0.99
193	90	0.250	0.80
212	100	0.190	0.65

Intake air temperature sensor

Location Right air cleaner intake (XJ12); right air cleaner (XJS).

Description The air temperature sensor is a temperature-sensitive resistor. As the ambient (intake) air temperature rises, the electrical resistance decreases providing an input to the ECM. The ECM uses this input as a measure of intake air density (as air temperature rises, its density decreases).

Air Temp.		Resistance (kilohms)	Voltage (±)
(°F)	(°C)		
14	-10	9.2	3.27
32	0	5.9	3.11
50	10	3.7	2.91
78	20	2.5	2.66
86	30	1.7	2.38
104	40	1.18	2.07
122	50	0.84	1.76
140	60	0.60	1.48

Oxygen sensor

Location Exhaust down-pipes.

Description The oxygen sensors (2) measure the oxygen concentration in the exhaust gases and provide an input to the ECM.

COOLANT TEMPERATURE SENSOR

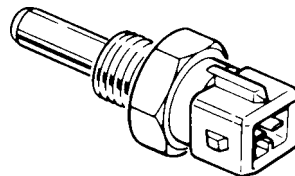

T850/1.25

AIR TEMPERATURE SENSOR

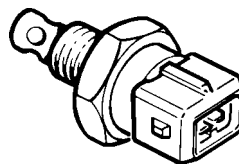

T850/1.26

OXYGEN SENSOR

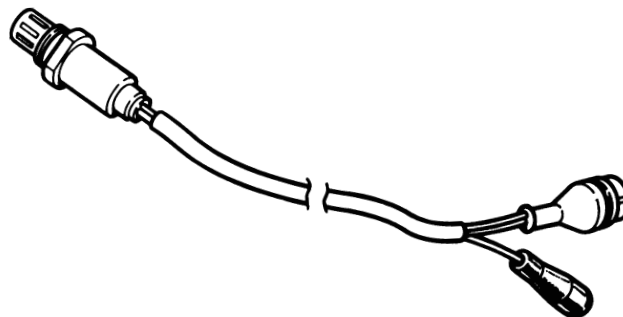

T850/1.27

6.0 Litre V12 / LM Engine Management System

Fuel Injection Components (continued)

EXTRA AIR VALVE

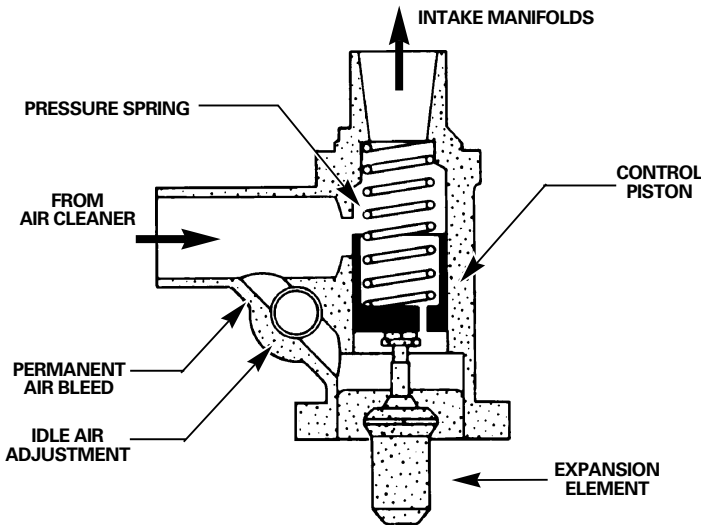
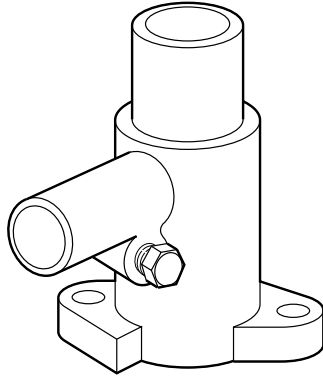

T850/1.28, 1.29

Extra air valve

Location Left cylinder head, rear.

Description The extra air valve has two functions: it provides the engine base idle speed through the adjustable idle air bleed, and it provides warm-up idle speed stabilization through the variable air duct. The duct area is varied by a temperature sensitive expansion element, in contact with engine coolant, that moves a control piston. As the coolant temperature increases, the area of the duct is gradually reduced until, at a coolant temperature of 140 to 158°F, it closes completely.

Supplementary air valve

Location Right air cleaner back plate.

Description The supplementary air valve allows additional throttle bypass air into the intake manifolds to stabilize the idle speed during air conditioning compressor operation. The valve operates in all gear selector positions.

SUPPLEMENTARY AIR VALVE

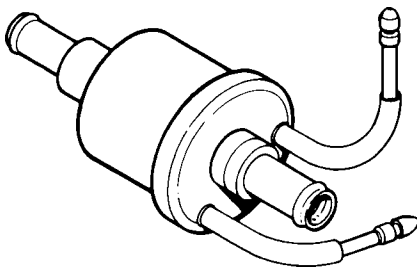

T850/1.30

6.0 Litre V12 / LM Engine Management System

Hot start switch

Location Fuel rail, right.

Description The hot start switch switches current between the air injection relay (switched by the ECM) and the hot start solenoid vacuum valve. The switch contacts close at 158°F and above.

Hot start solenoid vacuum valve

Location Above right thermostat housing.

Description The normally open solenoid vacuum valve closes when current is applied.

Air injection solenoid vacuum valve

Location Right cylinder head, rear.

Description The normally closed solenoid vacuum valve opens when current is applied.

Purge valves

Location Right front inner fender (XJ12); charcoal canister (XJS).

Description The purge valve is a solenoid operated valve that is normally open. The valve closing and subsequent rate of vapor flow (opening) is varied by the "length" of the pulsed electrical signal provided from the ECM.

HOT START SWITCH

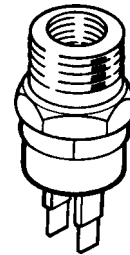

T850/1.31

HOT START SOLENOID VACUUM VALVE

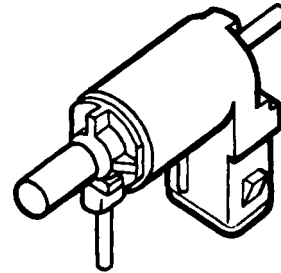

T850/1.32

AIR INJECTION SOLENOID VACUUM VALVE

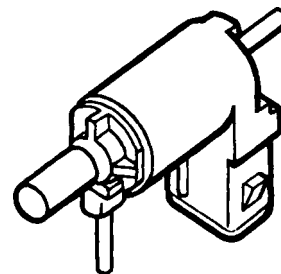

T850/1.33

PURGE VALVE

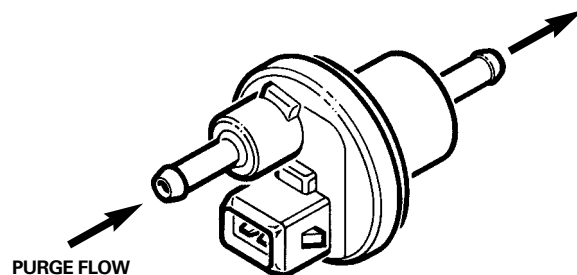

T850/1.34

6.0 Litre V12 / LM Engine Management System

Ignition: Overview

The ignition system is a digital microprocessor controlled system that eliminates vacuum and mechanical advance controls. The microprocessor memory contains ignition timing strategy with precise timing for engine speeds, loads, and modes of operation. The microprocessor, in the ignition ECM, receives inputs from engine sensors to program the necessary ignition timing. The double-deck two-rotor distributor distributes the high tension voltage to A bank (right) via the lower deck and to B bank (left) via the upper deck. The low-voltage circuit is switched by the ignition ECM via the two power modules to the two ignition coils. High voltage is generated by the ignition coils and supplied to the distributor.

The inputs supplied to the ECM from the engine sensors form two groups of control parameters: primary inputs and secondary inputs. The crankshaft position and engine-speed inputs are necessary for the engine to start. The remaining inputs effect engine operation but are not necessary for engine start.

Primary Inputs

- Crankshaft position — TDC sensor
- Engine speed — engine speed (flywheel) sensor
- Engine load — manifold absolute pressure sensor

Secondary Inputs

- Throttle position — idle switch
- Intake air temperature — air temperature switch

Other Functions

- Engine speed output
- Ignition retard (torque reduction) during transmission shift

NOTE: The sensors and switches are unique to the digital ignition system and are not used or shared by the fuel injection system.

Engine speed outputs

The ignition ECM provides engine speed outputs for the following:

- Tachometer
- Fuel injection control
- Fuel pump B control
- Transmission control

6.0 Litre V12 / LM Engine Management System

6.0 LITRE V12 IGNITION CONTROL

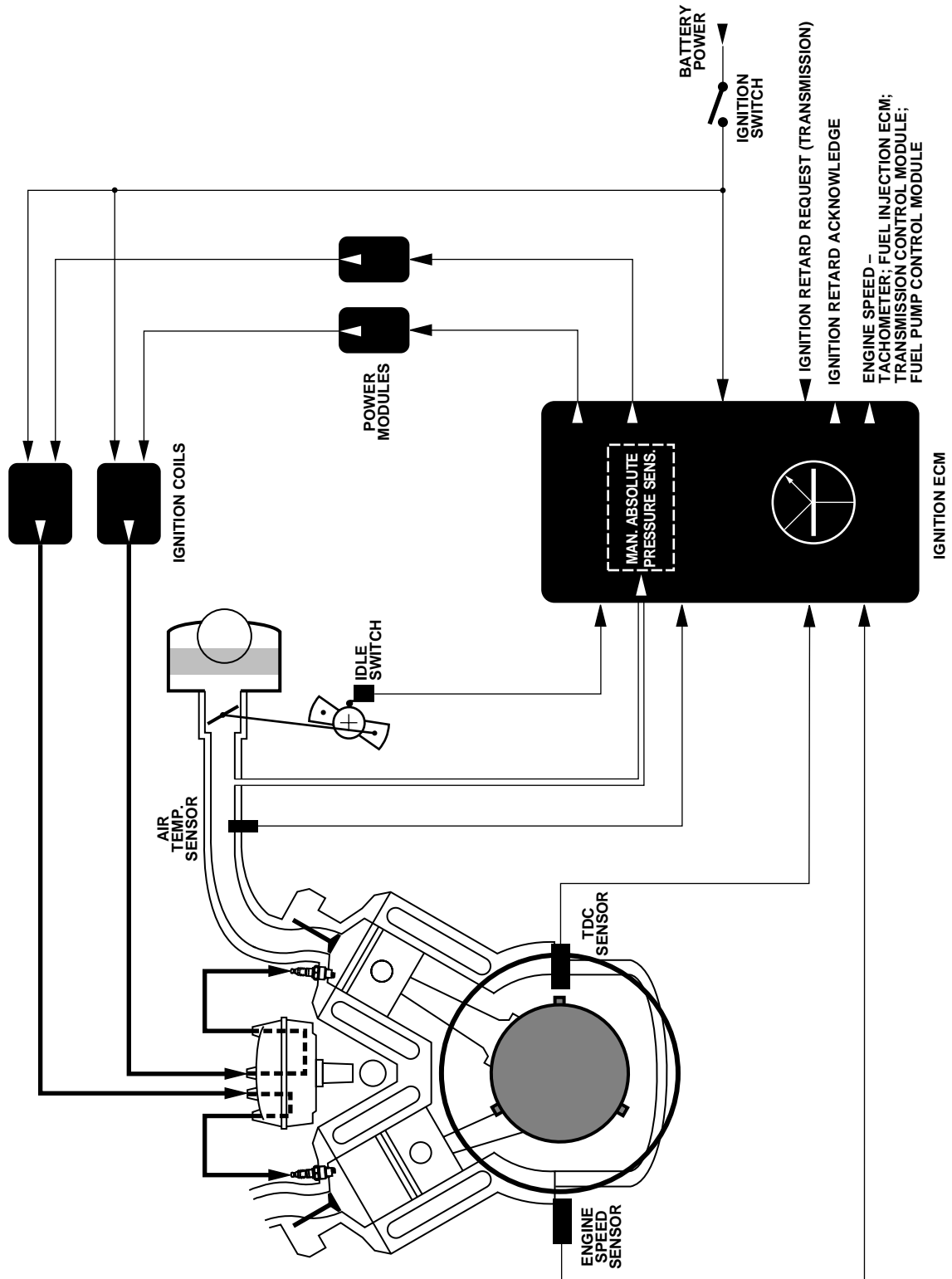

T850/1.35

6.0 Litre V12 / LM Engine Management System

Ignition Timing Control

Ignition timing synchronization

During all engine operating modes, the crankshaft position sensor (TDC sensor) input is used by the ECM to time spark delivery. Crankshaft position is referenced from A bank. The ECM times spark delivery for both banks from the A bank reference.

Engine starting

Ignition timing during cranking and start-up is determined from engine speed, intake air temperature and throttle position. Ignition timing moves from engine starting to normal running at 350 rpm.

Engine speed is obtained from the engine speed (flywheel) sensor; intake air temperature is obtained from the intake air temperature sensor; throttle position is obtained from the throttle switch.

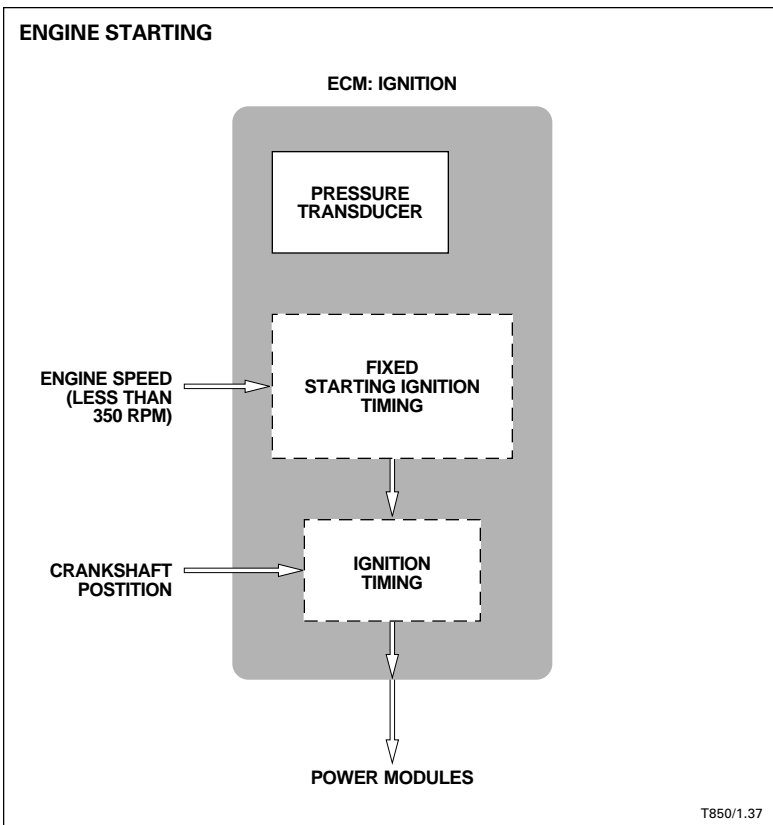
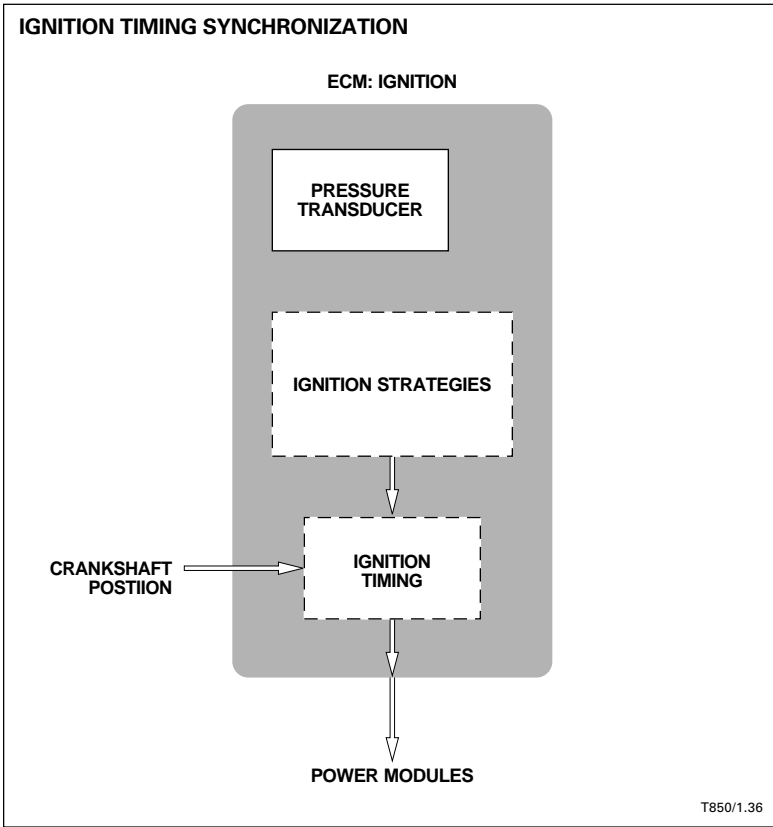

6.0 Litre V12 / LM Engine Management System

Closed throttle running

Ignition timing during closed throttle operation is programmed separately for idle and deceleration. Closed throttle running is enabled by the ECM from the idle switch input.

When the idle switch is closed, the ECM does not recognize the engine load (manifold absolute pressure sensor) input and uses the idle portion of the ignition strategy for ignition timing. The idle strategy uses engine speed and intake air temperature.

Engine speed is obtained from the engine speed (flywheel) sensor; engine intake air temperature is obtained from the intake air temperature sensor.

Open throttle running

Ignition timing during open throttle running is determined by primary inputs from engine speed and engine load and from secondary inputs from intake air temperature. Engine speed is obtained from the engine speed (flywheel) sensor; engine load is obtained from the manifold absolute pressure sensor; intake air temperature is obtained from the intake air temperature sensor.

The ECM memory incorporates an ignition timing strategy with ignition timing information stored for 16 engine load and 16 engine speed sites. A value number relating to the required ignition timing is generated from the strategy based on the engine load and speed inputs. If the engine load and speed is between sites, a value number is calculated from the surrounding sites. The ignition timing requirement is then modified depending on intake air temperature.

Ignition retard / transmission control

The ignition ECM receives an ignition retard request from the transmission control module during certain transmission apply and release functions. Before the transmission completes the function, an acknowledgment of the request is made by the ignition ECM. The momentary ignition retard reduces engine torque to ensure a "quality" shift. Ignition timing is retarded up to 20° with a limit of 8° ATDC. The retard is applied for a maximum of 1.2 seconds after which the ECM gradually returns to the engine speed / load strategy over a 0.5 second period.

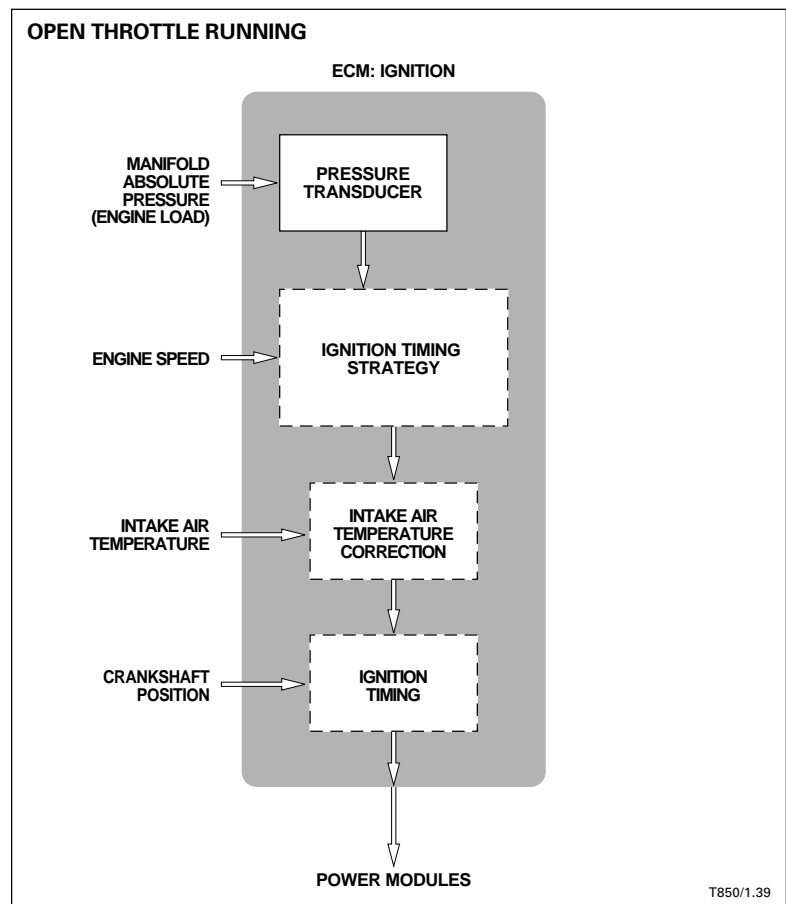
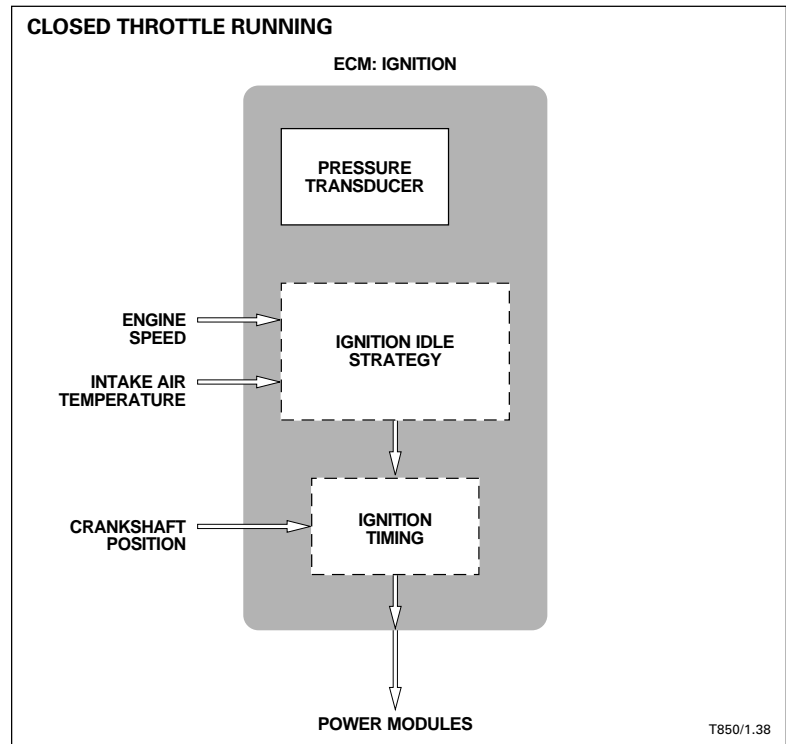

6.0 Litre V12 / LM Engine Management System

ENGINE CONTROL MODULE: IGNITION

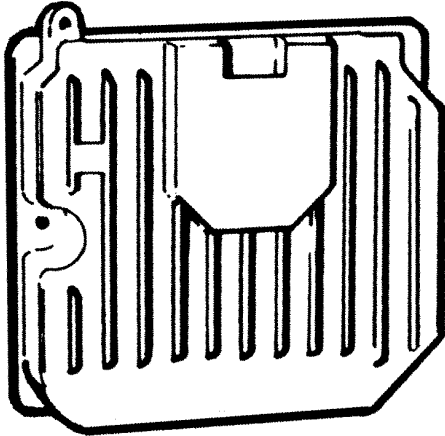

T850/1.40

Ignition Components

Engine control module (ECM): Ignition

Location Front passenger footwell, A post trim panel.

Description The ECM contains the microprocessor for receiving analog inputs from the engine sensors and producing the ignition timing, which is accessed and delivered from the ignition strategy stored in the memory. Integral in the ECM is the manifold absolute pressure sensor.

Top dead-center sensor

Location Front crankshaft pulley.

Description The sensor is triggered by a three toothed reluctor to produce a TDC reference for A bank.

TOP DEAD-CENTER SENSOR

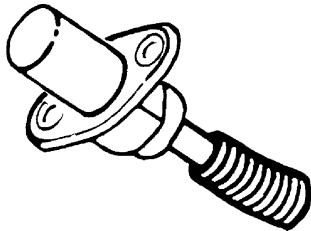

RESISTANCE: 700 – 800 OHMS

T850/1.41

Engine speed sensor

Location Flywheel ring gear.

Description The sensor is triggered by the flywheel ring gear teeth, which act as a reluctor to produce an engine speed input to the ECM.

ENGINE SPEED SENSOR

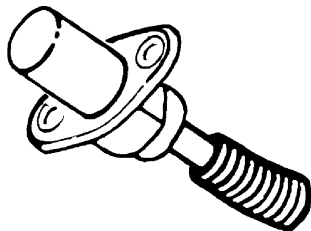

RESISTANCE: 700 – 800 OHMS

T850/1.42

6.0 Litre V12 / LM Engine Management System

Idle switch

Location Throttle turntable.

Description The micro switch closes when the throttle is closed, signaling the ECM that the engine is at idle or decelerating.

Intake air temperature sensor

Location Right air cleaner back plate.

Description The intake air temperature sensor is a temperature-sensitive resistor. As the air temperature rises, the electrical resistance decreases providing an air temperature input to the ECM.

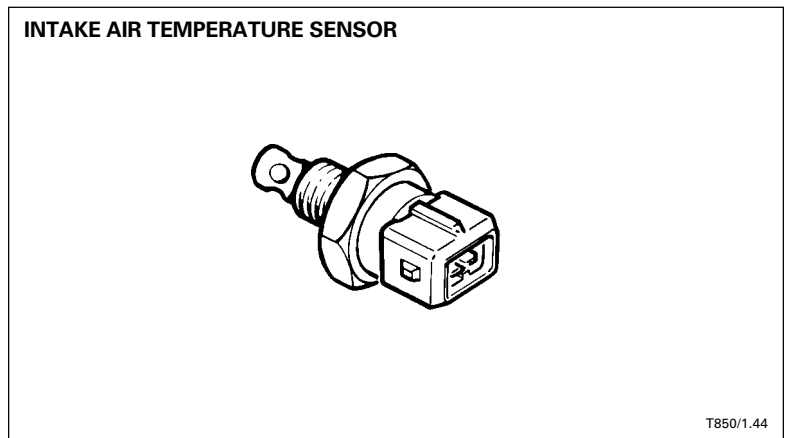
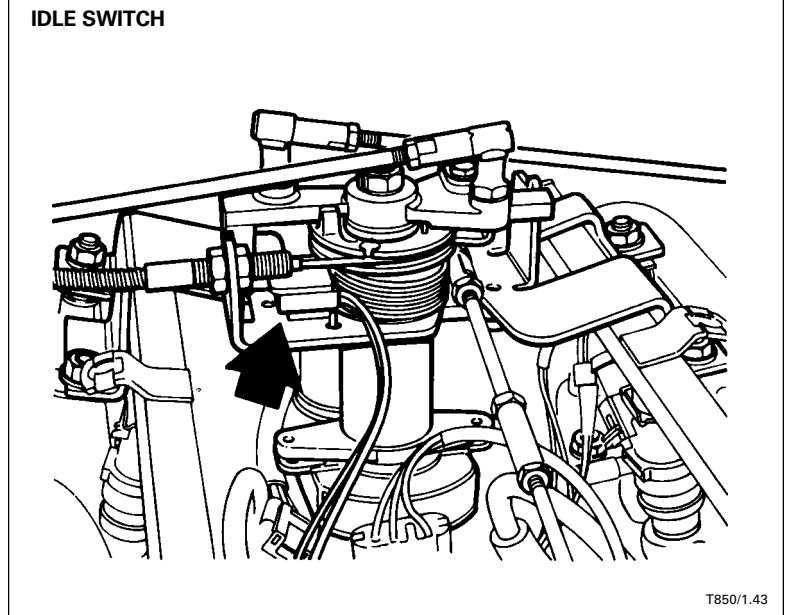

6.0 Litre V12 / LM Engine Management System

Ignition Components (continued)

POWER MODULE

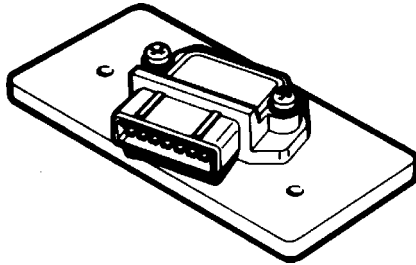

T850/1.45

Power modules

Location Front bulkhead component panel (XJ12); upper radiator support (XJS).

Description The power modules switch the low voltage circuit to ground when signaled by the ECM.

Ignition coils

Location Engine vee: A bank – red ident on harness plug; B bank – yellow ident on harness plug.

Description The ignition coils generate high voltage current for distribution to the spark plugs.

Distributor

Location Engine vee.

Description The distributor is a double-deck design with the upper rotor distributing high voltage current to B bank spark plugs and the lower rotor distributing high voltage current to A bank spark plugs.

IGNITION COIL

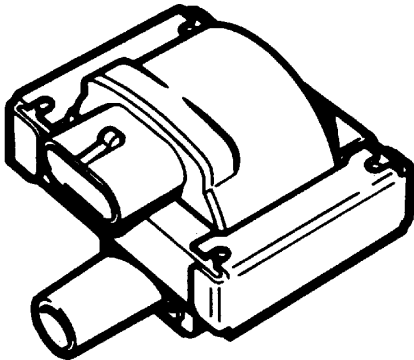

T850/1.46

DISTRIBUTOR

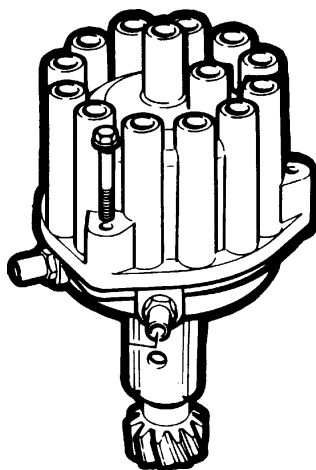

T850/1.47